



# Tiny Door and Window Sensor v0.3

Johannes S. [JohSka]  
4. Jan, 2017

## Voltage Regulator with Enable/Shutdown Pin

P1

UBAT=3.0-5.5V

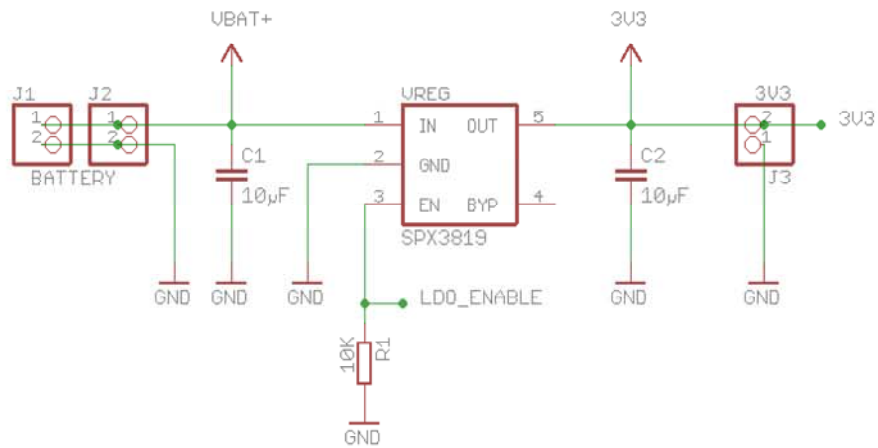

## ESP8266

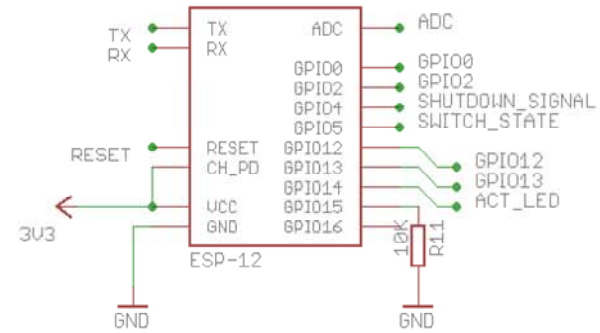
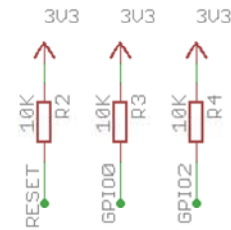
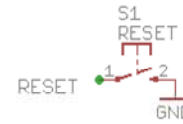

## UBAT Voltage Divider

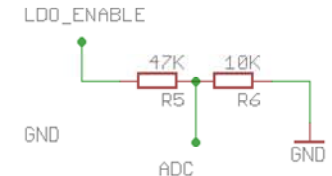

## Levelshifter for the switch signal

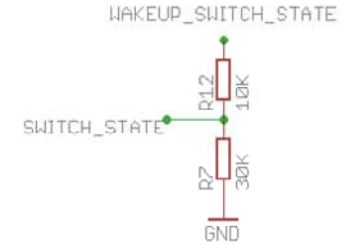

## ATTiny

P3

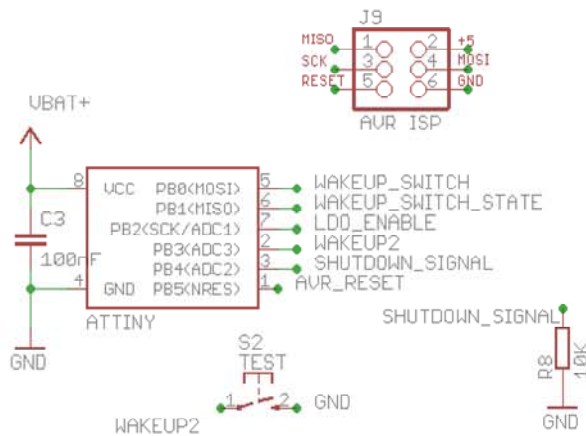

## Reed Switch

P4

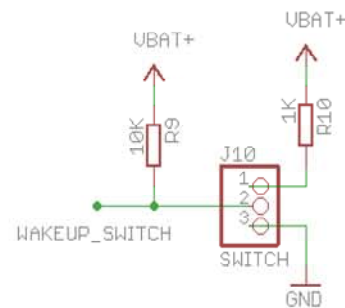

## LEDs

P5



## Optional pin headers

P6

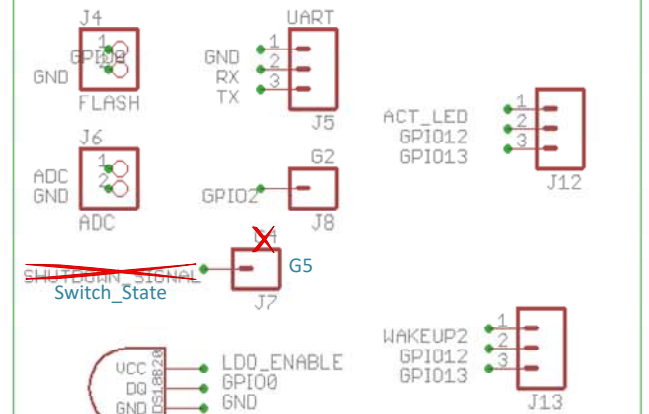

P2

ier

GND

atch signal

TATE

