

Transcranial Magnetic Stimulation

From Basics to Multimodal Imaging

Axel Thielscher
MPI for Biological Cybernetics
Tübingen, Germany

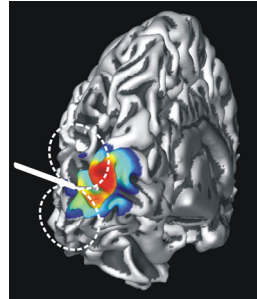

Course Objectives

You will learn

- **how** TMS works in general (physical & physiological basics)
- **what** can be done with TMS (and what TMS cannot do)
- **how** it is done practically
- **why** it is done in a particular way (pitfalls & physiological background)

Planned Sessions:

- 1) History of TMS; **Physical and physiological basics of TMS**
- 2) **Motor cortex stimulation**
- 3) **Repetitive TMS protocols**
- 4+5) **Virtual lesion approach**
- 6-8) **Multimodal approaches**
- 9+10) **Practical Hands-On Training**



Today's Schedule

- History & **Basic principle**
- **Temporal & spatial properties** of the fields induced by TMS
- How the induced field acts on a nerve fiber
- **Basic motor cortex stimulation:**
 - Effects of **waveform** and **current direction**
 - **Cortex or white matter:** What is stimulated in the brain?



History & Basic principle

Basic principle: Faraday's law:

- A **time-varying** magnetic field induces an electric field in conducting materials.
- The electric field induced, e.g. in a wire results in a measurable voltage. By this, the dynamo powers the lighting of your bicycle.
- The electric field induced in a brain can activate neurons.

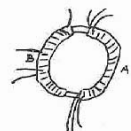

D'Arsonval (1896):

- Placing a subject's head in a magnetic field (110V, 30A, 42 Hz) causes magnetophosphenes, vertigo and sometimes syncopes(!).
- The article was written in French, so that not too many people read it.

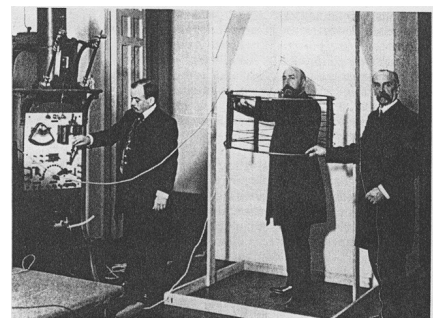

History & Basic principle

Thompson (1910)

- 800A of power-line current (50Hz??)
- „faint flickering illumination, colorless or a blush tint“

Dunlap (1911)

- Thompson used a transformer between the power-line and the coil that produced a **loud hum**: The phosphenes might have been due to psychological effects!
- First **placebo-controlled** experiment in the history of TMS: The transformer could either drive the coil, or a resistor to produce the same sound without real stimulation (i.e., **sham stimulation**).
- His results confirmed Thompson's observations

Magnusson&Stevens (1911, 1914)

- Systematic tests of different current frequencies



History & Basic principle

Anthony Barker and colleagues (Barker et al, 1985; Jalinous et al. 1985)

- First stimulation of peripheral nerves (1982) and the human motor cortex (1985) with a modern stimulator

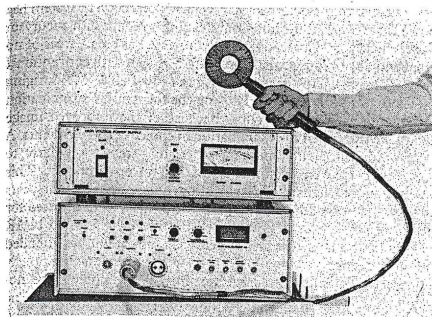

Fig 1—Magnetic stimulator and coil.

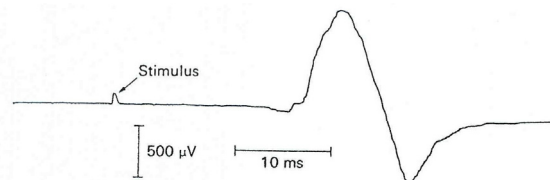
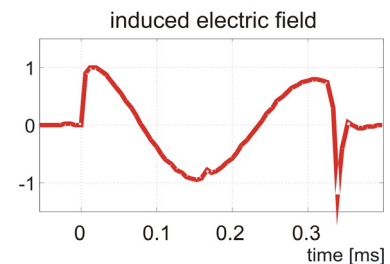
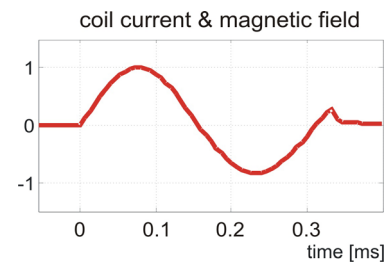
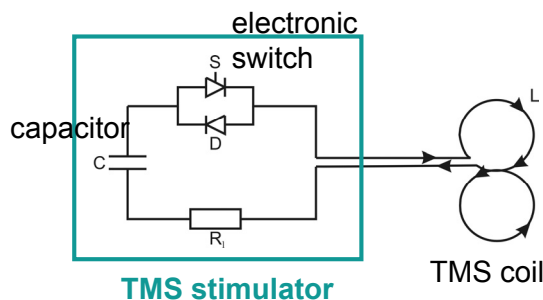

Fig. 1. Action potential (surface electrodes) in forearm flexor muscles, after a magnetic stimulus to the opposite motor area.



Technical principles of modern stimulators

- Capacitor C is charged to ≤ 3 kV, the circuit is then closed via an electronic switch so that the current flow starts
- Coil current: Sine-wave (≤ 10 kA), switched off again after one cycle
- Coil current has two peaks (positive & negative), so this is called **biphasic stimulation**
- The induced electric field (max. strength: ~ 70 - 140 V/m) is the **temporal derivative** of the magnetic field



Technical principles of modern stimulators (cont'd)

- **Monophasic stimulation:** First quarter of a sine-wave, then current decays slowly to zero
- Less efficient than biphasic stimulation, as the capacitor has to be completely reloaded after each stimulus
- Neural effects are easier to characterize, as there is only one clear-cut peak

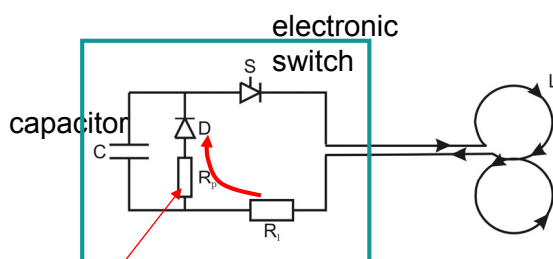

After the first quarter, the current flows through this resistor and is transformed into heat (rather than flowing back into the capacitor)

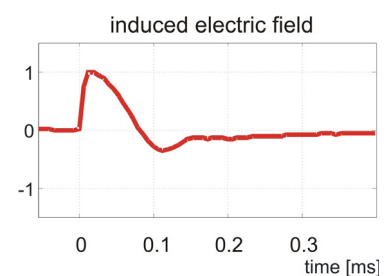
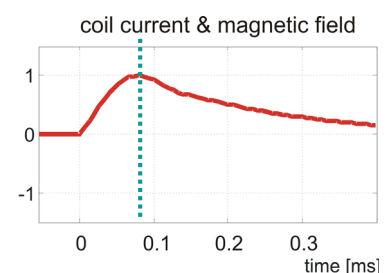

How the induced field acts on the membrane potential

- The nerve membrane acts as **lossy integrator**: It accumulates the current flow caused by the induced electric field
- **Rule of thumb**: The temporal shape of the membrane potential change is roughly similar to the coil current (as long as no spike is induced, ...)
- Second peak of biphasic waveform is stronger than monophasic peak → Probably one of the reasons why biphasic stimuli activates cortical neurons at lower stimulation intensities

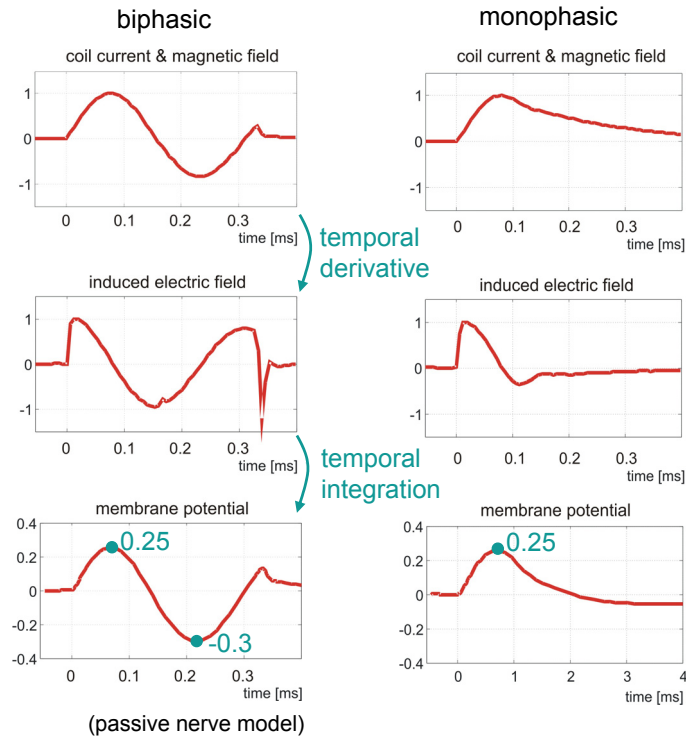

How the induced field acts on the membrane potential (cont'd)

Mono- vs. biphasic stimulation: *In vitro* recordings (Maccabee et al. 1998)

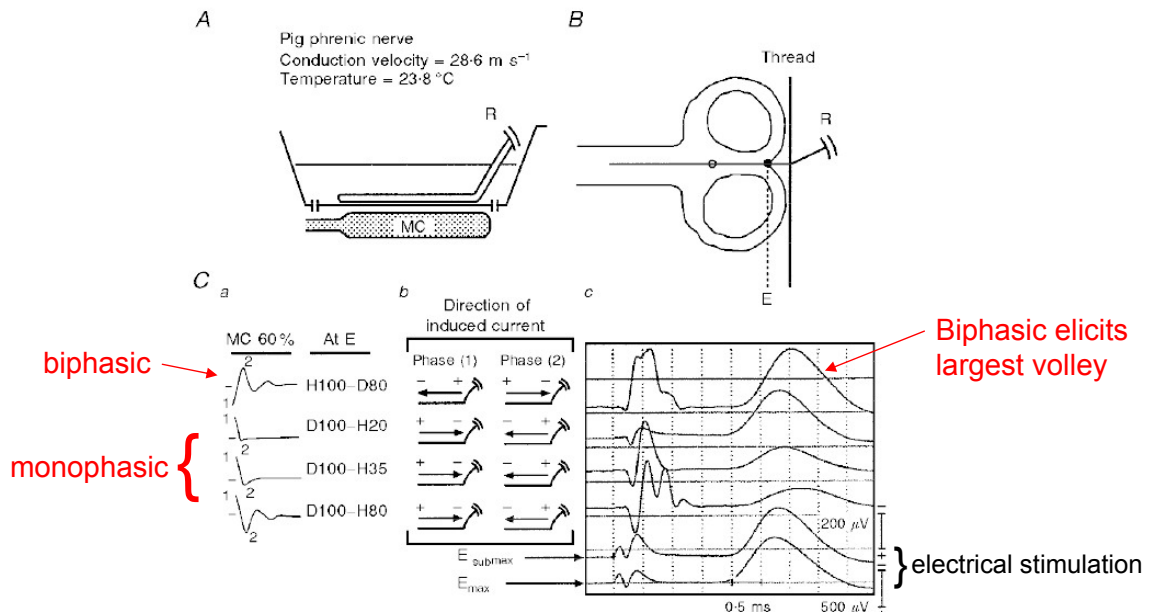

Take-Home Messages (Part 1)

- Modern TMS exists since 1985
- A brief, but strong time-varying magnetic field induces an electric field in the brain; the latter activates the neurons
- Two pulse forms exist, mono- and biphasic:
 - Monophasic has only one peak, so it's impact on neural tissue is (a little bit) easier to characterize
 - Biphasic is more efficient, because the stimulator doesn't have to completely recharge after each pulse, and it activates neurons at a lower stimulation intensities.



Spatial distribution of the induced electric field

Where do we stimulate?

- Look at the **spatial distribution** of the induced electric field
- The two most widely used types of TMS coils: **Round** and **figure-8 (butterfly)** coils

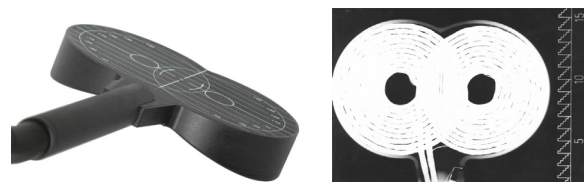
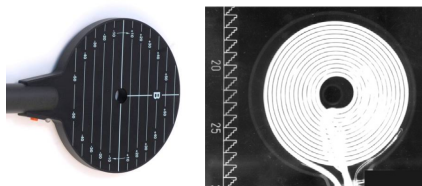

(MagVenture; formerly Medtronic, Dantec)



Spatial distribution of the induced field (cont'd)

Shown is the electric field induced in a **homogeneous** conductor, calculated in a plane parallel to the coil plane

Round

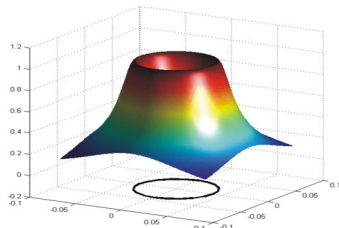
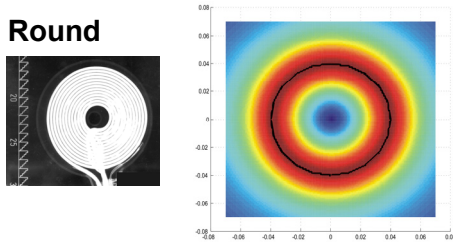

- Field has “trough shape”
- Rather unfocal

Figure-8

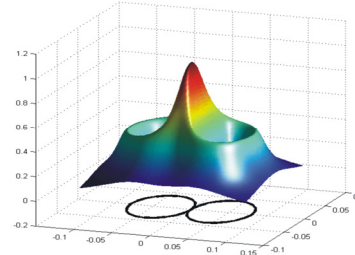
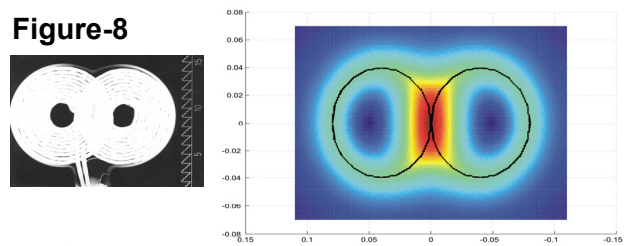

- Field peaks underneath the intersection of the two wire loops



Spatial distribution of the induced field (cont'd)

Small vs. large double coil

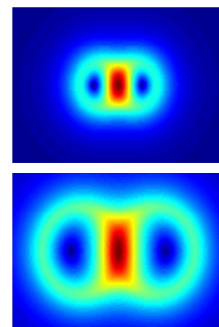
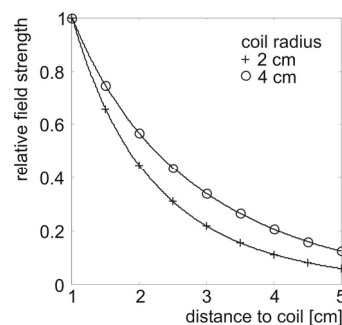
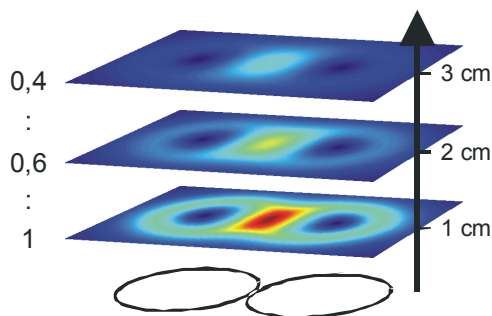

- Field distributions in different depth planes are scaled versions of each other; their general shape stays approx. the same
- Field strength decays approx. quadratically with increasing distance to the coil
- No 3D-focus possible!
- Smaller coils are more focal, but have a steeper decrease; only suited for targeting superficial structures



Spatial distribution of the induced field (cont'd)

- Up to now we considered the electric field induced in a **homogeneous** conductor
- How do the different electrical conductivities (skull, liquor, gray&white matter) affect the induced field?
- Calculation of the electric field for a **spherical conductor** (Sarvas 1987), simulating the effects of several interleaved spherical shells
- Results:
 - The maximum is reduced to 72%
 - The skull-liquor boundary suppresses the radial field components → The induced field flows always approx. parallel to the skull, independent on the coil tilt!

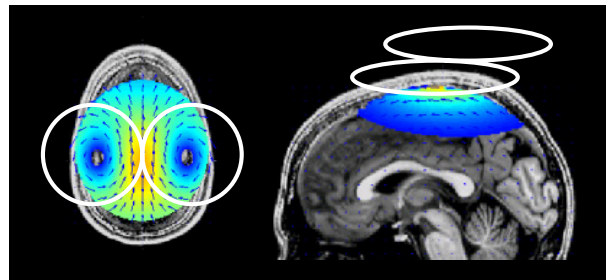
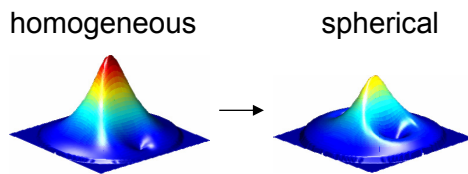
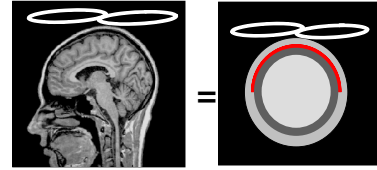

Take-Home Messages (Part 2)

- Two most widely used coil designs: Round and figure-8 coils
- Round coils have a „stimulation trough“, i.e., they are rather unfocal
- Figure-8 coils have a field peak underneath their center
- No 3D-focus! The more superficial the brain tissue, the stronger its stimulation
- The electric field is oriented approx. parallel to the skull

How TMS affects a nerve fiber

- Is the position with the maximal field strength the most likely stimulation point in the cortex?
- Let's look at a **single nerve fiber**
- Question:** Does a nerve fiber get activated at the point with the maximal electric field?
- Answer:** Well, it depends ...

- The induced electric field changes the **membrane potential**. When this change is large enough (and has the right sign), the membrane will be depolarized
- Electric field can be subdivided into two parts: **parallel** and **perpendicular** to the nerve fiber
- Perpendicular** part is thought to have only minor impact on the membrane potential, and can be neglected in first approximation

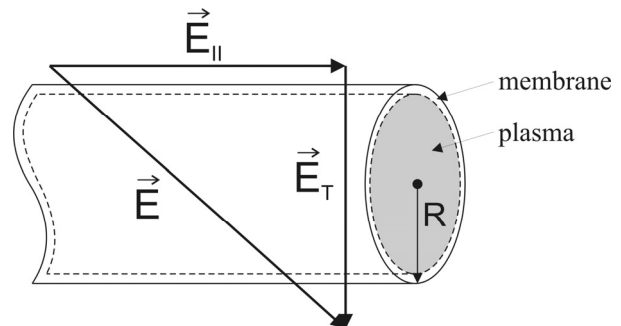

assume $R = 10 \mu\text{m}$, $E_T = 100\text{V/m}$
 $\rightarrow V_{\text{ind}} = 2RE_T = 2 \text{ mV}$
 \rightarrow too small to depolarize the membrane

How TMS affects a nerve fiber

Let's look at the impact of the **parallel** part of the induced electric field on the membrane potential

- Long straight nerve in a homogeneous field:
Membrane potential is unaffected; no stimulation

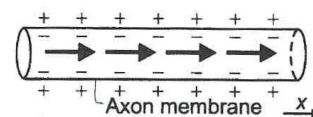

(Ruohonen&Ilmoniemi, 1999)

- Long straight nerve in a **spatially varying field**: Charge is accumulated

- The positions at which the electric field changes the most are most strongly affected, i.e. they are the most likely stimulation sites

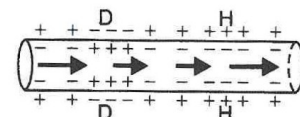

- In other words, for straight nerves, the **spatial derivative** $\frac{\partial}{\partial l} E_{\parallel}(l, t)$ of the part of the electric field that is parallel to the nerve fiber determines the stimulation sites
- $\frac{\partial}{\partial l} E_{\parallel}(l, t)$ is called the **activating function** of the nerve

How TMS affects a nerve fiber

2) Long straight nerve in a **spatially varying field** (cont'd): Stimulation by a **double coil**

Calculation of $\frac{\partial}{\partial l} E_{\parallel}(l, t)$ for a nerve in a homogeneous conductor:

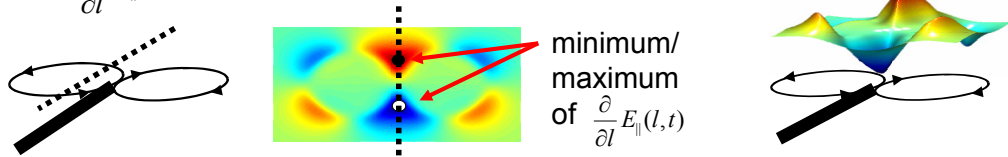

In vitro recordings:

- **Monophasic** stimuli
- Latencies of the volleys are different for R_1 and R_2
- Changing the current direction in the coil reverses the order of arrival

(Maccabee et al. 1993)

Straight peripheral nerves are most easily stimulated at the peaks of the spatial derivative of E

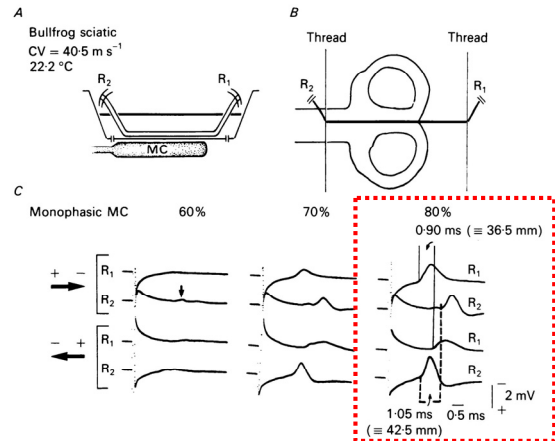

How TMS affects a nerve fiber

3) **Nerve bends** result in peaks of $\frac{\partial}{\partial l} E_{\parallel}(l, t)$:

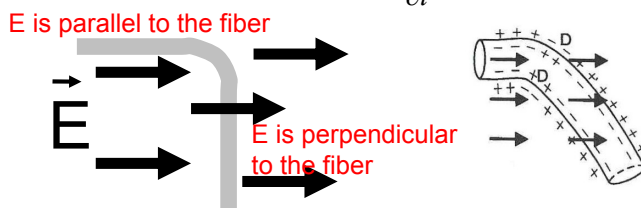

- In contrast to a long straight nerve, bends get also stimulated by a homogeneous field

In vitro recordings:

- **Monophasic** stimuli
- Amplitude of volley increases with bend angle
- The stronger the electric field at the bend, the stronger the volley (data not shown)

(Maccabee et al. 1993)

Nerve bends are low-threshold points

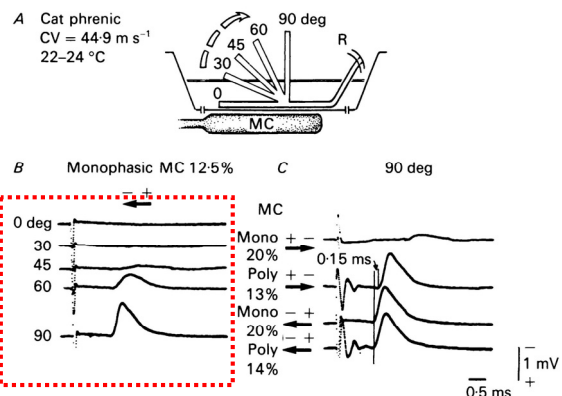

Take-Home Messages (Part 3)

- The activation of a nerve fiber is determined by the **spatial derivative** of the electric field component that is parallel to the fiber. This is called **activating function**.
- For straight **peripheral nerve fibers**, the locus of excitation is therefore spatially offset to the point at which E is maximal
- **Nerve bends are low-threshold points**. The stronger the local electric field at the bend, the stronger its excitation (same for nerve endings & branches; data not shown)
- **Cortical neurons** are thought to be stimulated at their many bends, terminals and branches. The bends, etc. will be affected the most at the point at which E is maximal.
- It follows that **the likely stimulation point in the cortex is the point of the electric field maximum**.
- Excitation of a cortical neuron is likely to occur at the axon. The soma has a much higher electric capacity and therefore a higher excitation threshold (e.g., Nagarajan et al. 1993; Nowak&Bullier 1998)



Motor Cortex Stimulation: Practical Aspects

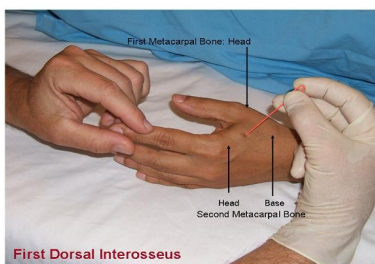

© CASA Engineering, 2005



© CASA Engineering, 2005

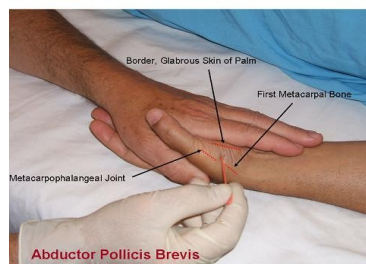

© CASA Engineering, 2005

The cortical representations of hand muscles (typically FDI, APB, ADM) have the lowest TMS stimulation thresholds

The M1 representation of the hand is located on the hand knob of the precentral gyrus

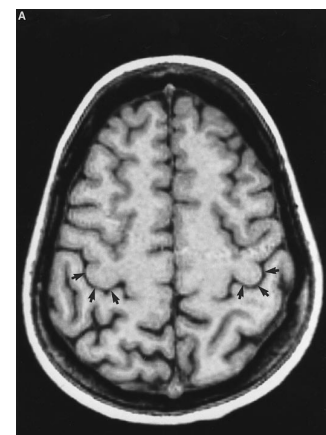

(Yousry et al. 1997)



Motor Cortex Stimulation: Practical Aspects

Motor-evoked potentials (MEPs) are usually recorded using surface electrodes

- easy, non-invasive
- temporal smearing of the signal, as it is a compound potential from many single motor units

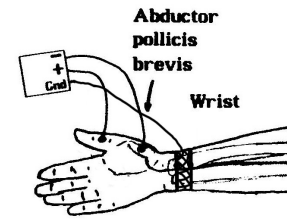

Needle electrodes can record the signal from single muscle end plates

- invasive, but allows to record single spikes



Electrodes implanted in the epidural cervical space

- only in patients
- record the descending volleys prior to reaching the spinal motor neurons
- group signal of neurons projecting to different muscles

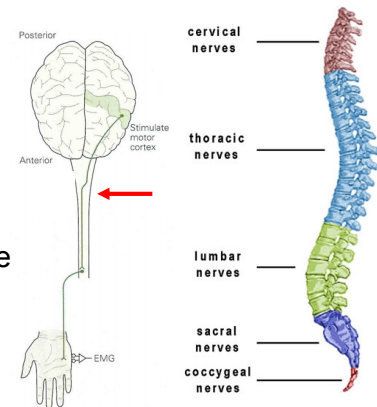

Motor Cortex Stimulation: Practical Aspects

Finding the right coil position & stimulation intensity

- Choose a target muscle, a waveform (mono- or biphasic) and a coil orientation
- **“Hot Spot” search:**
 - Place the coil approx. above the motor cortex, and increase the intensity until you get a response
 - Move the coil and look for a position giving higher responses (~5s pause between two pulses)
 - At this position, lower the intensity until you get only a small response
 - Now search for a position with higher response again, etc.
- Determining the **resting motor threshold (rMT):**
 - At the Hot Spot, start with a suprathreshold intensity
 - Lower the intensity in a stepwise procedure until you have reached **the lowest intensity** that gives you **at least 5 out of 10 EMG responses** with an amplitude of $>50 \mu\text{V}$. This is the MT.
 - The muscle has to be relaxed during the search.



Motor Cortex Stimulation: Effects of current direction

Monophasic stimulation:

- MEP amplitude shows clear dependency on coil orientation (stimulation intensity was held constant)
- Physiological cause of this “anisotropy” is unknown
- Maximal response occurs when the induced field direction is **posterior-anterior**, with an angle of 45° to the midline (i.e., perpendicular to the central sulcus)
- Replicated for FDI, ADM & APB (*Pascual-Leone et al., 1994*)

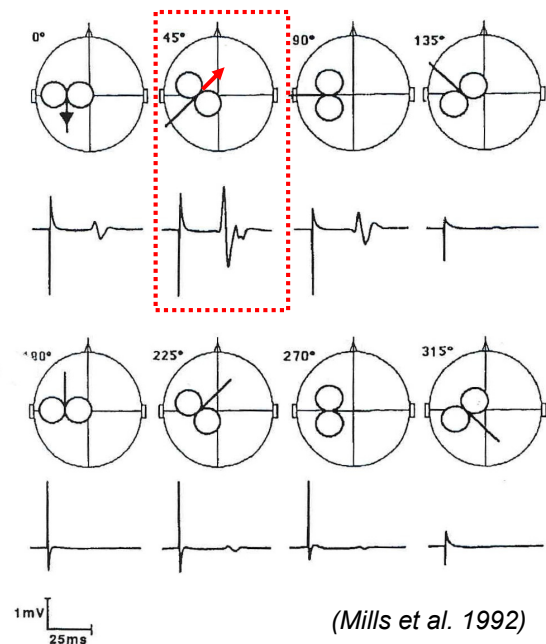

Motor Cortex Stimulation: Effects of current direction

Motorthresholds for mono- vs. biphasic stimulation

- Biphasic is more efficient than monophasic (as predicted by the passive nerve model)
- Contrary to monophasic stimuli, biphasic is most efficient when the first peak of the induced field is directed from **anterior to posterior**, perpendicular to the central sulcus

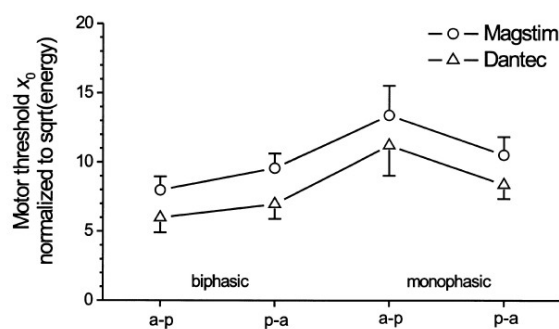

Pulse waveform, and current direction (*Kammer et al. 2001*)

(In order to compare the MTs across different stimulator types and manufacturers, the MTs were normalized to the sqrt of the maximal energy stored in the capacitors)



Motor Cortex Stimulation: Coil Orientations with Lowest MTs

- To make things a little bit more confusing, the currents in the TMS coils of MagStim and MagVenture (Dantec, Medtronic) have opposite directions
- So let's summarize:

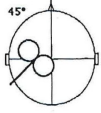
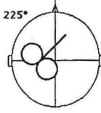
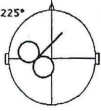
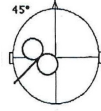
waveform	optimal direction (in brain)	optimal coil orientation	
		MagStim	MagVenture
monophasic	pa		
biphasic	ap - pa		



“Anisotropic” Responses to TMS: A General Principle?

- Dependence of the neural response strength on the induced current direction has been shown for the **motor system** and **early visual areas**
- It is unknown if this effect occurs for all cortical regions
- For example, it is unknown if the current direction used to stimulate the left DLPFC for the treatment of depression is optimal or not.

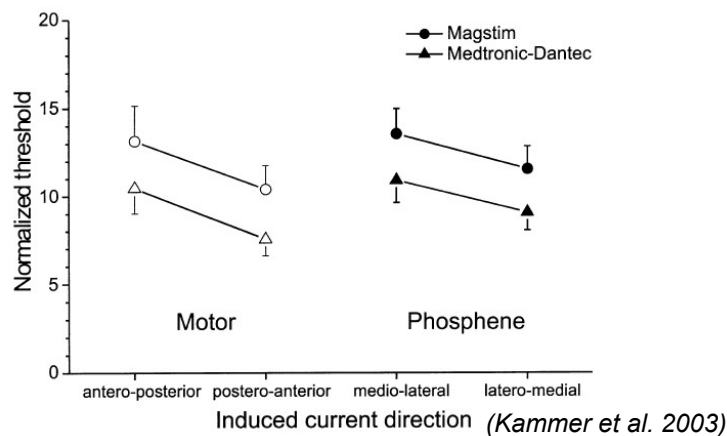

Motor Cortex Stimulation: Gray or white matter?

Which neurons are targeted by TMS?

Hypotheses:

- Cortical neurons at their many bends, terminals & branches
- The axons of pyramidal cells projecting from the bank of the precentral gyrus to the spinal cord

How can this be tested?

→ Look at the elicited **I- and D-waves**

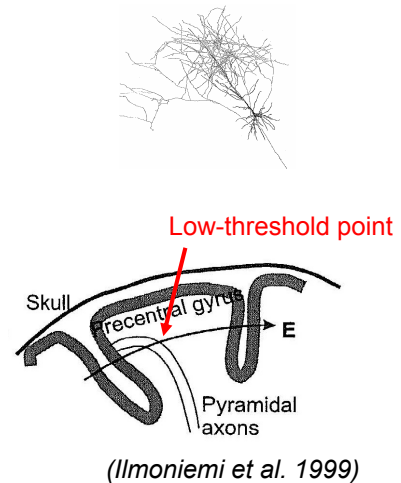

Motor Cortex Stimulation: Gray or white matter?

I- and D- waves

Electrical stimulation in animals:

- (Anodal) stimulation of the motor cortex & recording of single pyramidal tract neurons
- At threshold, a single fast volley is elicited
- At higher intensities, later volleys follow (**periodicity ~1.5ms**)
- The first volley is still seen after cortical ablation or cooling (*Patton&Amassian 1954*)
→ probably elicited by **direct** stimulation of the pyramidal tract axons: **D-wave**
- However, the later volleys disappear
→ originate in the gray matter: **I- (indirect) waves** (numbered according to their temporal order: I1, I2, I3, ...)

Motor Cortex Stimulation: Gray or white matter?

I- and D- waves

Transcranial Electrical Stimulation (TES) in humans (*Merton&Morton 1980*):

- (Anodal) stimulation of the motor cortex, often combined with recordings from cervical epidural electrodes in patients
- Painful, as current is passed through the skull (high electrical resistance)
- In contrast to TMS, the main current direction is perpendicular to the skull surface

The results replicate the findings from direct cortical electrical stimulation in animals (*e.g., Day et al 1989, diLazzaro et al 2004*):

- At threshold, a single volley with short latency is induced. Its amplitude is not affected by changes of cortical excitability (voluntary contraction) → **D-wave**
- At higher intensities, later volleys follow with an periodicity of ~1.5ms → **I-waves**

→ Compare the volleys elicited by TMS with TES to see if TMS affects mainly gray or white matter

Motor Cortex Stimulation: Gray or white matter?

I- and D- waves for monophasic TMS: Current directions revisited

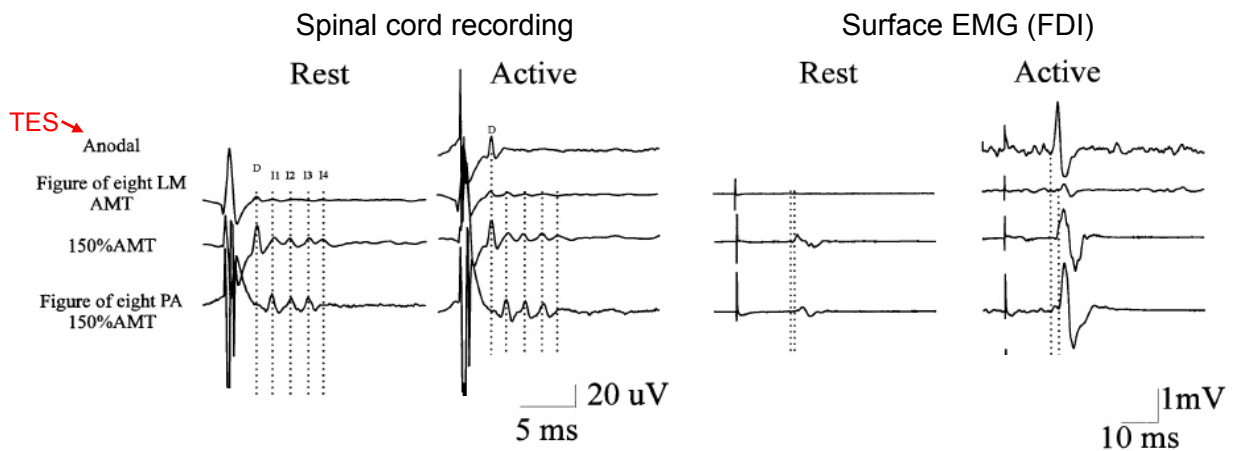

The effects of monophasic TMS depends on the current direction:

- **Latero-medial (LM):** mainly **D-wave** at threshold, so it also targets white matter (LM can be used instead of TES as reference to define the D-wave)
- **PA:** only **I-waves**, so the main target is gray matter

Motor Cortex Stimulation: Gray or white matter?

I- and D- waves for monophasic TMS: Current directions revisited

- **PA:** I1-wave at threshold
 - **AP:** also I-waves; but a different pattern (I3-wave at threshold in one subject; slightly different onset latencies compared to PA in all subjects)
- Both affect gray matter, but are thought to target different neural subpopulations

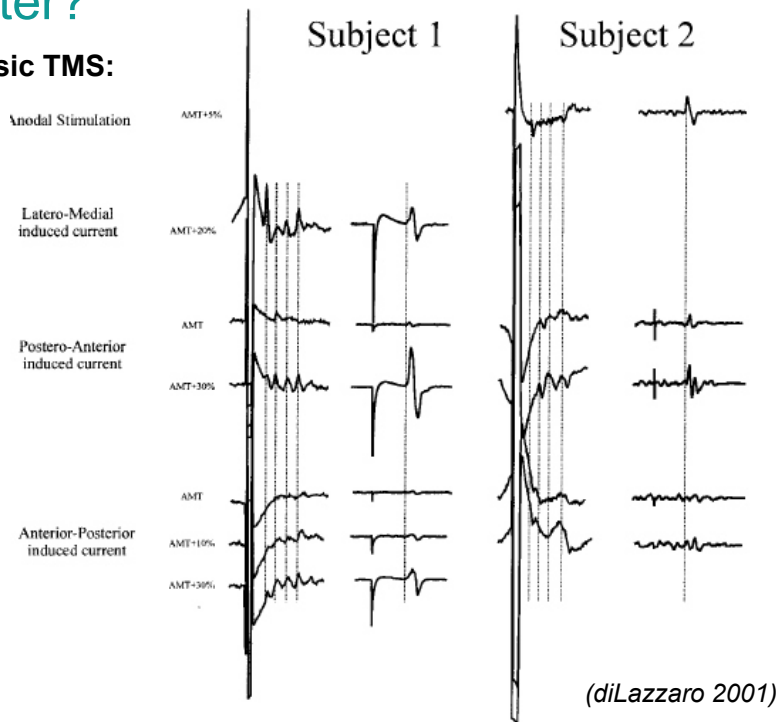

Motor Cortex Stimulation: Gray or white matter?

I- and D- waves for biphasic TMS

- I-waves for PA-AP and AP-PA
- more complex patterns compared to monophasic stimulation
- for AP-PA, the pattern of recruitment of D- and I-waves with increasing stimulation intensity is similar to that of monophasic PA stimulation

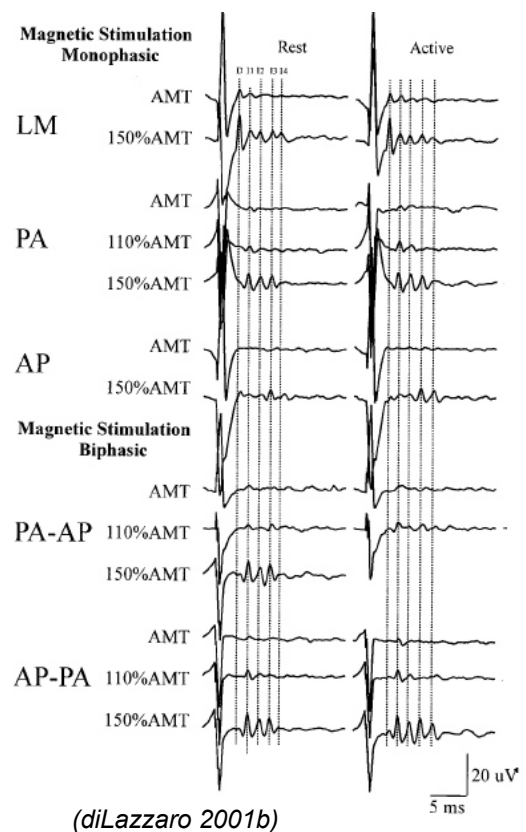

Take-Home Messages (Part 4)

The effect of current directions

- Motor thresholds differ with current direction
- Most efficient induced current directions:
 - Monophasic: posterior-anterior, perpendicular to the central sulcus
 - Biphasic: AP-PA, also perpendicular to CS
- The neural structures targeted by TMS depend on current direction:
 - White & gray matter for monophasic LM
 - Gray matter for monophasic AP, PA, biphasic PA-AP, AP-PA

Practical relevance:

- Selecting the “right” current direction helps you to minimize the subjects’ discomfort, and reduces the problem of coil heating in rTMS protocols
- As different coil orientations target different neural subpopulations, the impact of, e.g. drugs on cortical excitability might be observable for one coil orientation, but not for others.

