



雅仪科技——【嵌入式智能互联设备】软硬件方案供应商。
专注【远程网络视频监控系统】研发设计。更多资讯浏览：
<http://www.travellinux.com> 获取。



Hi3519 V101 Professional HD IP Camera SoC

Brief Data Sheet

Issue 01
Date 2016-03-16

Copyright © HiSilicon Technologies Co., Ltd. 2016. All rights reserved.

No part of this document may be reproduced or transmitted in any form or by any means without prior written consent of HiSilicon Technologies Co., Ltd.

Trademarks and Permissions



HISILICON, and other HiSilicon icons are trademarks of HiSilicon Technologies Co., Ltd.

All other trademarks and trade names mentioned in this document are the property of their respective holders.

Notice

The purchased products, services and features are stipulated by the contract made between HiSilicon and the customer. All or part of the products, services and features described in this document may not be within the purchase scope or the usage scope. Unless otherwise specified in the contract, all statements, information, and recommendations in this document are provided "AS IS" without warranties, guarantees or representations of any kind, either express or implied.

The information in this document is subject to change without notice. Every effort has been made in the preparation of this document to ensure accuracy of the contents, but all statements, information, and recommendations in this document do not constitute a warranty of any kind, express or implied.

HiSilicon Technologies Co., Ltd.

Address: Huawei Industrial Base
Bantian, Longgang
Shenzhen 518129
People's Republic of China

Website: <http://www.hisilicon.com>

Email: support@hisilicon.com



Hi3519 V101 Professional HD IP Camera SoC

Key Specifications

Processor Core

- 800 MHz A7 core, supporting 32 KB I-cache, 32 KB D-cache, and 128 KB L2 cache
- 1.25G GHz A17 core, supporting 32 KB I-cache, 32 KB D-cache, and 256 KB L2 cache
- Neon acceleration, integrated FPU
- ARM@big-LITTLE architecture

Video Encoding

- H.264 BP/MP/HP
- H.265 Main Profile
- I/P/B frame, dual-P-frame reference
- MJPEG/JPEG baseline encoding

Video Encoding Performance

- Maximum 16-megapixel (4608 x 3456) resolution for H.264/H.265 encoding
- Real-time multi-stream H.264/H.265 encoding capability: 3840 x 2160@30 fps+1080p@30 fps + 3840 x 2160@2fps snapshot
- Maximum JPEG snapshot performance of 3840 x 2160@30 fps
- CBR/VBR control, ranging from 2 kbit/s to 100 Mbit/s
- Encoding frame rate ranging from 1/16 fps to 60 fps
- Encoding of eight ROIs

Intelligent Video Analysis

- Integrated IVE, supporting various intelligent analysis applications such as motion detection, perimeter defense, and video diagnosis

Video and Graphics Processing

- 3D denoising, image enhancement, and dynamic contrast improvement
- Anti-flicker for output videos and graphics
- 1/30x to 16x video scaling
- Seamless splicing of 2-channel videos
- 1/2x to 2x graphics scaling
- OSD overlaying of eight regions before encoding
- Video graphics overlaying of two layers (video layer and graphics layer)

ISP

- 2-channel independent ISP processing
- Adjustable 3A functions (AE, AWB, and AF)
- FPN removal
- Highlight compensation, backlight compensation, gamma correction, and color enhancement
- Defect pixel correction, denoising, and digital image stabilization
- Anti-fog
- Lens distortion correction and fisheye correction
- Picture rotation by 90° or 270°
- Picture mirroring and flipping
- Sensor built-in WDR, 4F/3F/2F frame-based/line-based WDR, and local tone mapping. The second channel of ISP

processing supports only sensor built-in WDR, 2F frame-based/line-based WDR, and local tone mapping.

- ISP tuning tools for the PC

Audio Encoding/Decoding

- Voice encoding/decoding complying with multiple protocols by using software
- Compliance with the G.711, G.726 and ADPCM protocols
- Audio 3A functions (AEC, ANR, and ALC)

Security Engine

- AES, DES, and 3DES encryption and decryption algorithms implemented by using hardware
- RSA1024/2048/4096 signature verification algorithm implemented by using hardware
- Hash-SHA1/256 and HMAC_SHA1/256 tamper proofing algorithms implemented by using hardware
- Integrated 512-bit OTP storage space and hardware random number generator

Video Interfaces

- VI Interfaces
 - Two sensor inputs. The maximum resolution for the main channel is 16 megapixels (4608 x 3456), and the maximum resolution for the second input is 8 megapixels (4096 x 2160).
 - 8-/10-/12-/14-bit RGB Bayer DC timing VI, at most 150 MHz clock frequency
 - BT.601, BT.656, or BT.1120 VI interface
 - Maximum 12-lane MIPI/LVDS/sub-LVDS/HiSPi interface for the main channel
 - Maximum 4-lane MIPI/LVDS/sub-LVDS/HiSPi interface for the second sensor interface
 - Compatibility with mainstream HD CMOS sensors provided by Sony, Aptina, OmniVision, and Panasonic
 - Compatibility with the electrical specifications of parallel and differential interfaces of various sensors
 - Programmable sensor clock output
- VO interfaces
 - One PAL/NTSC output for automatic load detection
 - One BT.1120/BT.656 VO interface for connecting to an external HDMI or SDI, supporting at most 1080p@60 fps output
 - LCD output

Audio Interfaces

- Integrated audio CODEC supporting 16-bit audio inputs and outputs
- I²S interface for connecting to an external audio CODEC
- Dual-channel differential MIC inputs for reducing background noises

Peripheral Interfaces

- POR
- External reset input
- Internal RTC
- Integrated 3-channel SAR ADC



Hi3519 V101 Professional HD IP Camera SoC

- Five UART interfaces
- IR interface, I²C interface, SSP master interface, and GPIO interface
- Eight PWM interfaces (four independent interfaces and four ones multiplexed with other pins)
- Two SD 3.0/SDIO 3.0 interfaces, supporting SDXC
- One USB 3.0/USB 2.0 host/device port
- One PCIe 2.0 interface in master/slave mode
- RGMII/RMII in 10/100 Mbit/s full-/half-duplex mode and 1000 Mbit/s full-duplex mode, and TSO network acceleration
- Body size of 10 mm x 10 mm (0.39 in. x 0.39 in.)
- Lead pitch of 0.4 mm (0.02 in.)

External Memory Interfaces

- DDR4/DDR3/DDR3L/LPDDR3 interface
 - 32-bit LPDDR3 interface with the maximum frequency of 800 MHz (1.6 Gbit/s)
 - 32-bit DDR4/3/3L interface with the maximum frequency of 933 MHz (1.866 Gbit/s)
 - Maximum capacity of 1024 MB for a 16-bit DDR SDRAM
 - Maximum total capacity of 2048 MB for two 16-bit DDR SDRAMs
- SPI NOR flash interface
 - 1-/2-/4-wire mode
 - 3-byte or 4-byte address mode
 - Maximum capacity of 32 MB
- SPI NAND flash interface, supporting the maximum capacity of 512 MB
- eMMC 5.0 interface, supporting the maximum capacity of 64 GB
- NAND flash interface
 - 8-bit data width
 - SLC or MLC
 - 4-/8-/24-/40-/64-bit ECC
 - Components with 8 GB or larger capacity
- Booting from the SPI NOR flash, SPI NAND flash, or NAND flash
- Booting from an eMMC or over PCIe

SDK

- Linux-3.18-based SDK
- High-performance H.265 PC/iOS/Android decoding library
- High-performance H.264 PC decoding library

Physical Specifications

- Power consumption
 - 1.25 W typical power consumption
 - Multi-level power saving mode
- Operating voltages
 - 0.9 V core voltage
 - 3.3 V I/O voltage and 3.8 V margin voltage
 - 1.2 V, 1.5 V, 1.35 V, or 1.2 V DDR4/3/3L/LPDDR3 SDRAM interface voltage
- Package
 - RoHS, FC-CSP



Hi3519 V101 Professional HD IP Camera SoC

Functional Block Diagram

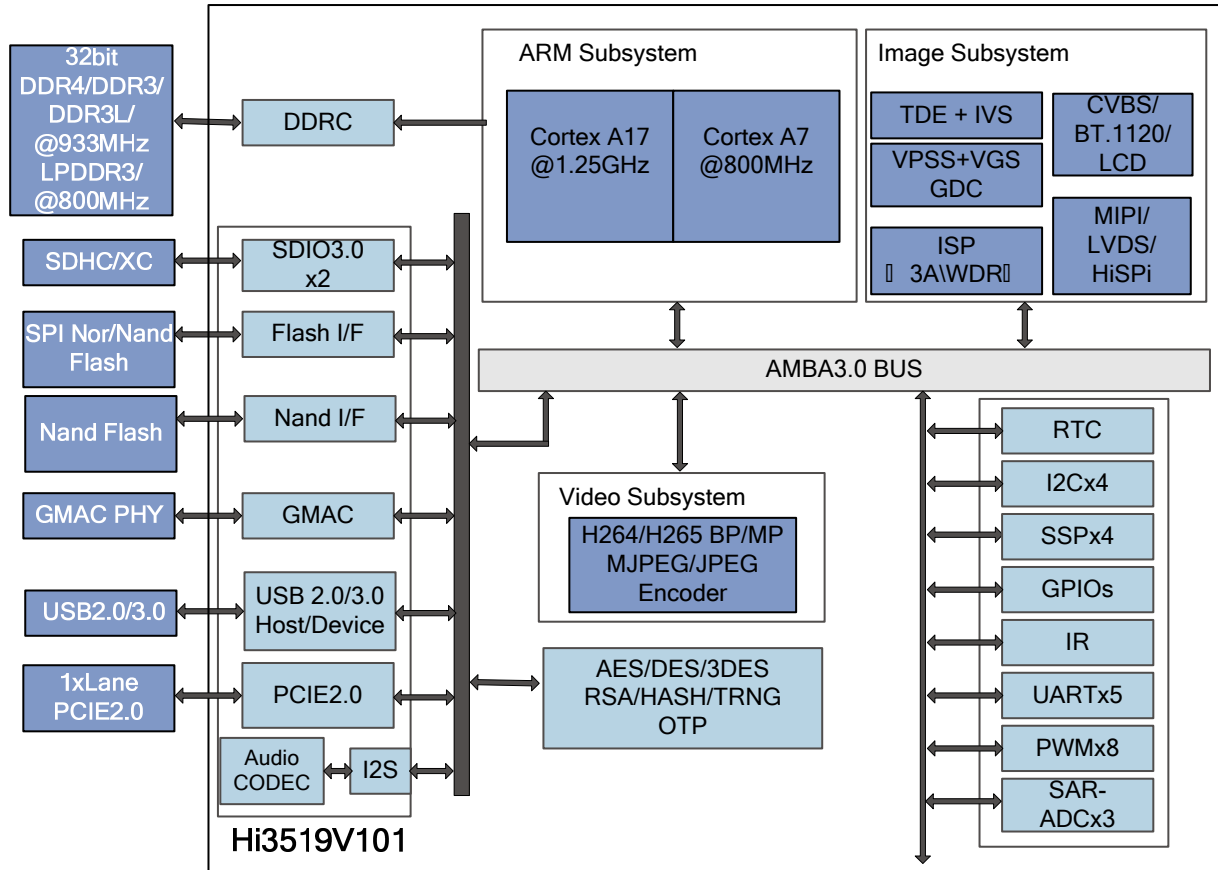

As a new-generation industry-specific SoC designed for the HD IP camera, Hi3519 V101 integrates a new-generation ISP and uses the latest H.265 video compression encoder in the industry as well as advanced low-power technology and architecture design. These features enable Hi3519 V101 to continuously maintain the leading position in the aspects of low bit rate, high picture quality, and low power consumption. Hi3519 V101 supports 90° or 270° rotation and lens distortion correction by using hardware, which meet requirements in various surveillance application scenarios. It also supports 3A algorithms, which allow customers to design various models of IP cameras that contain integrated camera cores. Hi3519 V101 integrates the POR, RTC, and audio CODEC and supports various sensor levels and clock outputs, which significantly reduces the EBOM cost of the HD IP camera based on Hi3519 V101. The Hi3519 V101 HiSilicon SDK features high stability and ease of use, supports rapid mass production, and facilitates system layout of DVRs, NVRs, and IP cameras.



Hi3519 V101 Professional HD IP Camera SoC

Hi3519 V101 HD IP Camera Solution

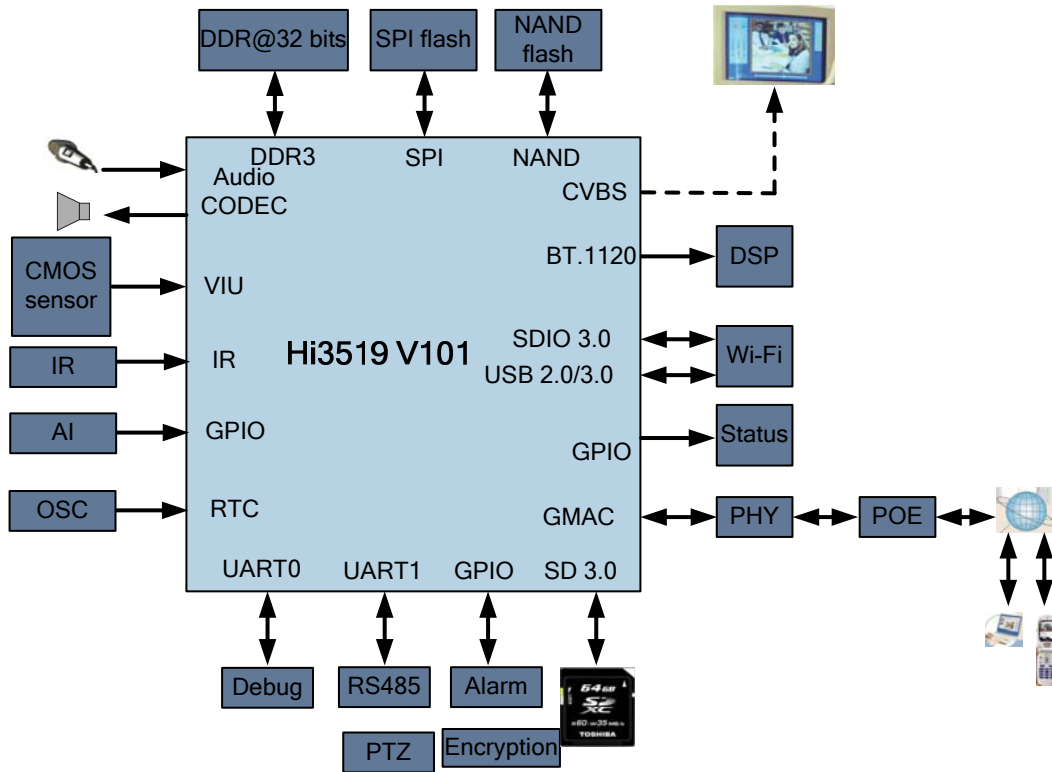



Acronyms and Abbreviations

3DES	triple data encryption standard
ADC	analog-to-digital converter
ADPCM	adaptive differential pulse code modulation
AE	automatic exposure
AEC	acoustic echo cancellation
AES	advanced encryption standard
AF	automatic focus
ALC	automatic level control
ANR	active noise reduction
AWB	automatic white balance
CBR	constant bit rate
CMOS	complementary metal-oxide-semiconductor
CODEC	coder/decoder
DCI	dynamic contrast improvement
DDR	double data rate
DES	data encryption standard
DPC	defect pixel correction
DVR	digital video recorder
EBOM	engineering bill of materials
ECC	error correcting code
eMMC	embedded multimedia card
FD	face detection
FPN	fixed pattern noise
FPU	floating-point unit
GPIO	general-purpose input/output
HD	high definition
HDMI	high definition multimedia interface
HiSPi	high-speed serial pixel interface
I ² C	inter-integrated circuit
I ² S	inter-IC sound
IR	infrared
ISP	image signal processor
IVE	intelligent video engine
LCD	liquid crystal display
LDC	lens distortion correction
LVDS	low-voltage differential signaling
MIC	microphone
MIPI	mobile industry processor interface
MLC	multi-level cell
NTSC	National Television System Committee
NVR	network video recorder
OSD	on-screen display
OTP	one-time programming
PAL	phase alternating line
PCIe	peripheral component interconnect express
POR	power-on reset
PWM	pulse-width modulation
RGMI	reduced gigabit media independent interface
RMII	reduced media independent interface
RoHS	Restriction of Hazardous Substances

**Hi3519 V101 Professional HD IP Camera SoC**

ROI	region of interest
RSA	Rivest-Shamir-Adleman
RTC	real-time clock
SAR	successive approximation register
SD	secure digital
SDI	serial digital interface
SDIO	secure digital input/output
SDK	software development kit
SDRAM	synchronous dynamic random access memory
SDXC	secure digital extended capacity
SLC	single-level cell
SoC	system-on-chip
SPI	serial peripheral interface
SSP	synchronous serial port
TFBGA	thin fine ball grid array
TSO	TCP segmentation offload
UART	universal asynchronous receiver transmitter
VBR	variable bit rate
VDMA	virtual direct memory access
VI	video input
VO	video output
WDR	wide dynamic range