

AL-AL_SG225_ALUMINUM @ 293.60K

Thermal cross sections

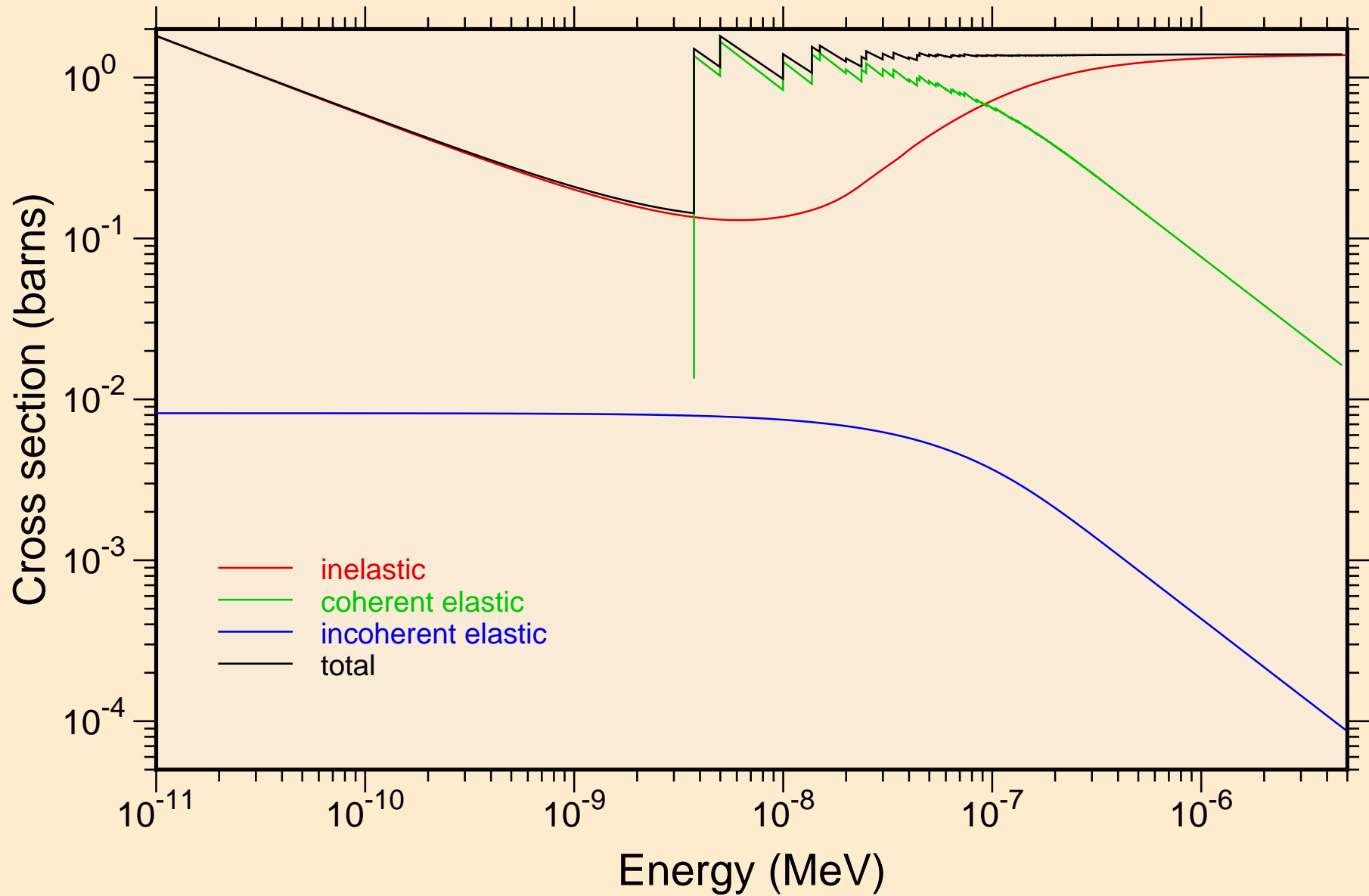

AL-AL_SG225_ALUMINUM @ 293.60K
Thermal mubar

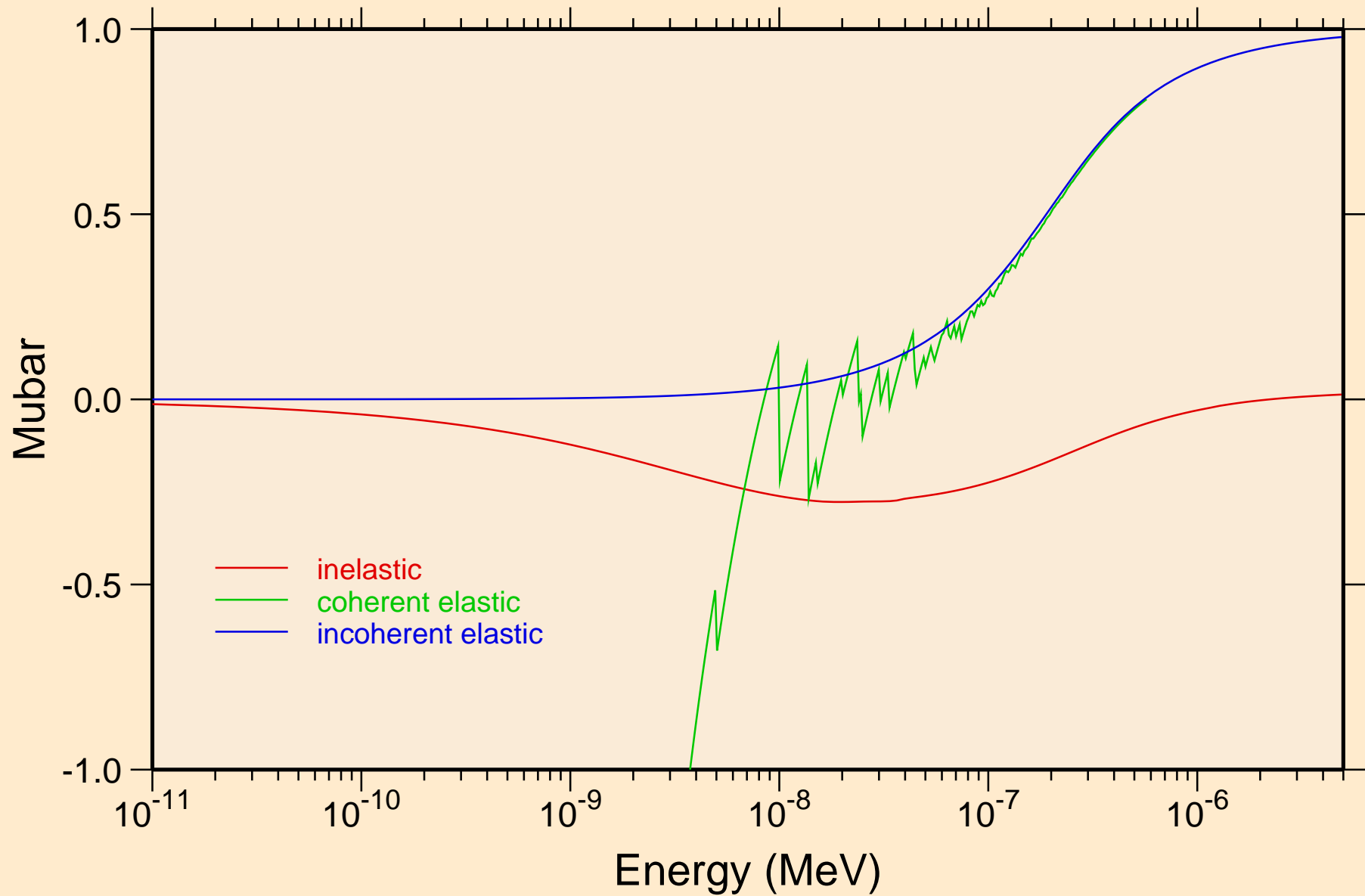

AL-AL_SG225_ALUMINUM @ 293.60K

Thermal ebar

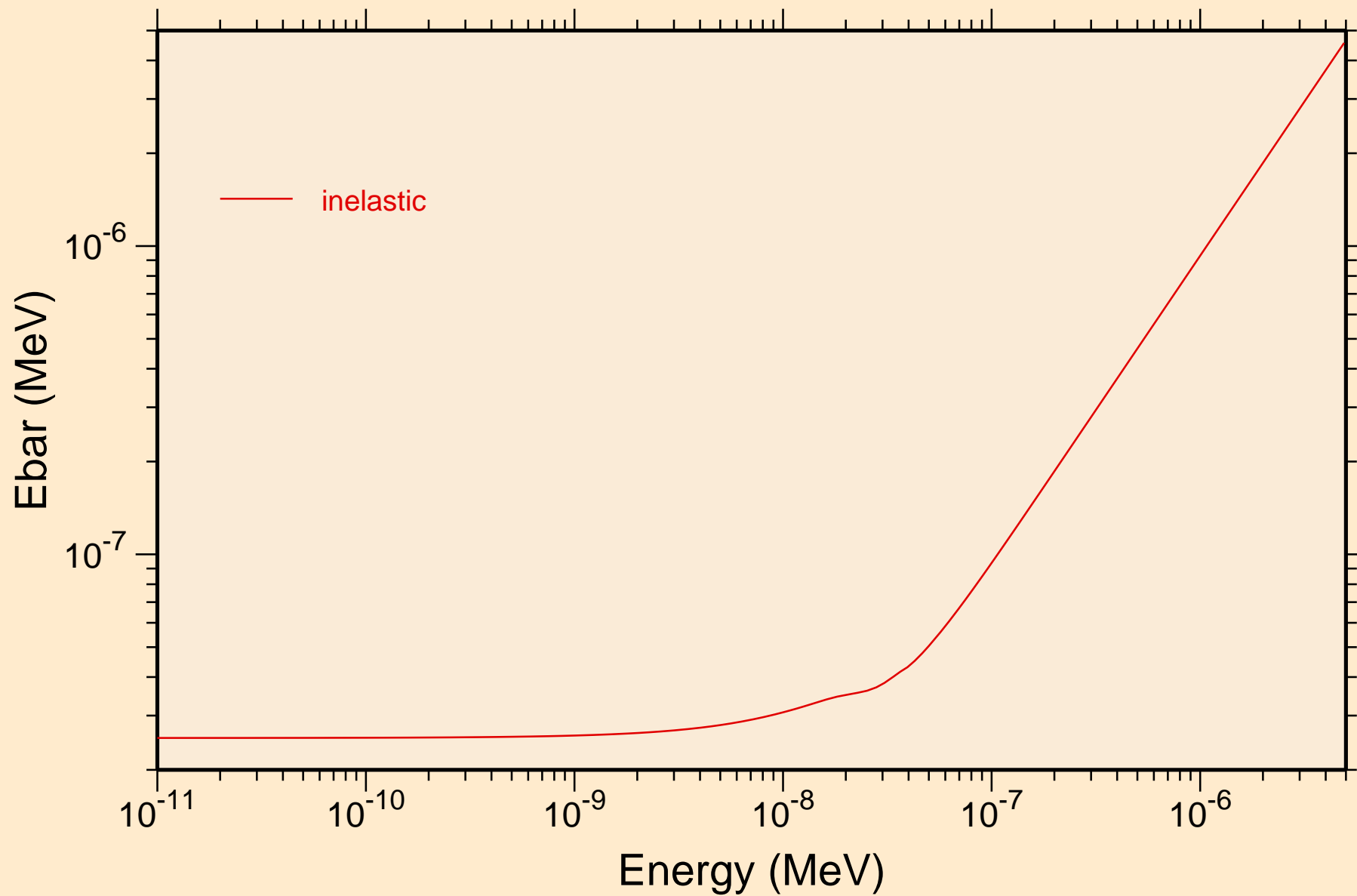

AL-AL_SG225_ALUMINUM @ 293.60K
thermal inelastic

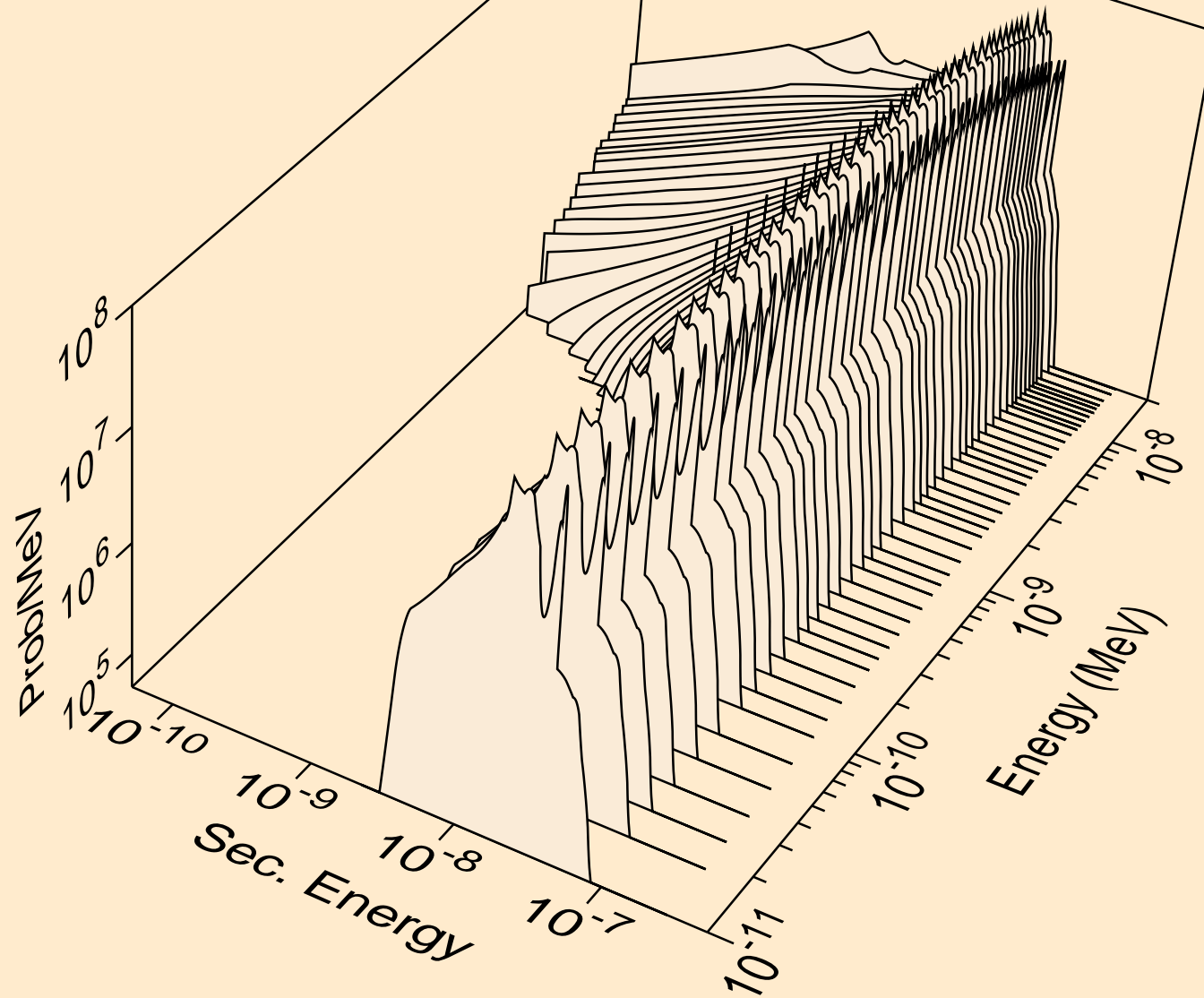

AL-AL_SG225_ALUMINUM @ 293.60K
thermal inelastic

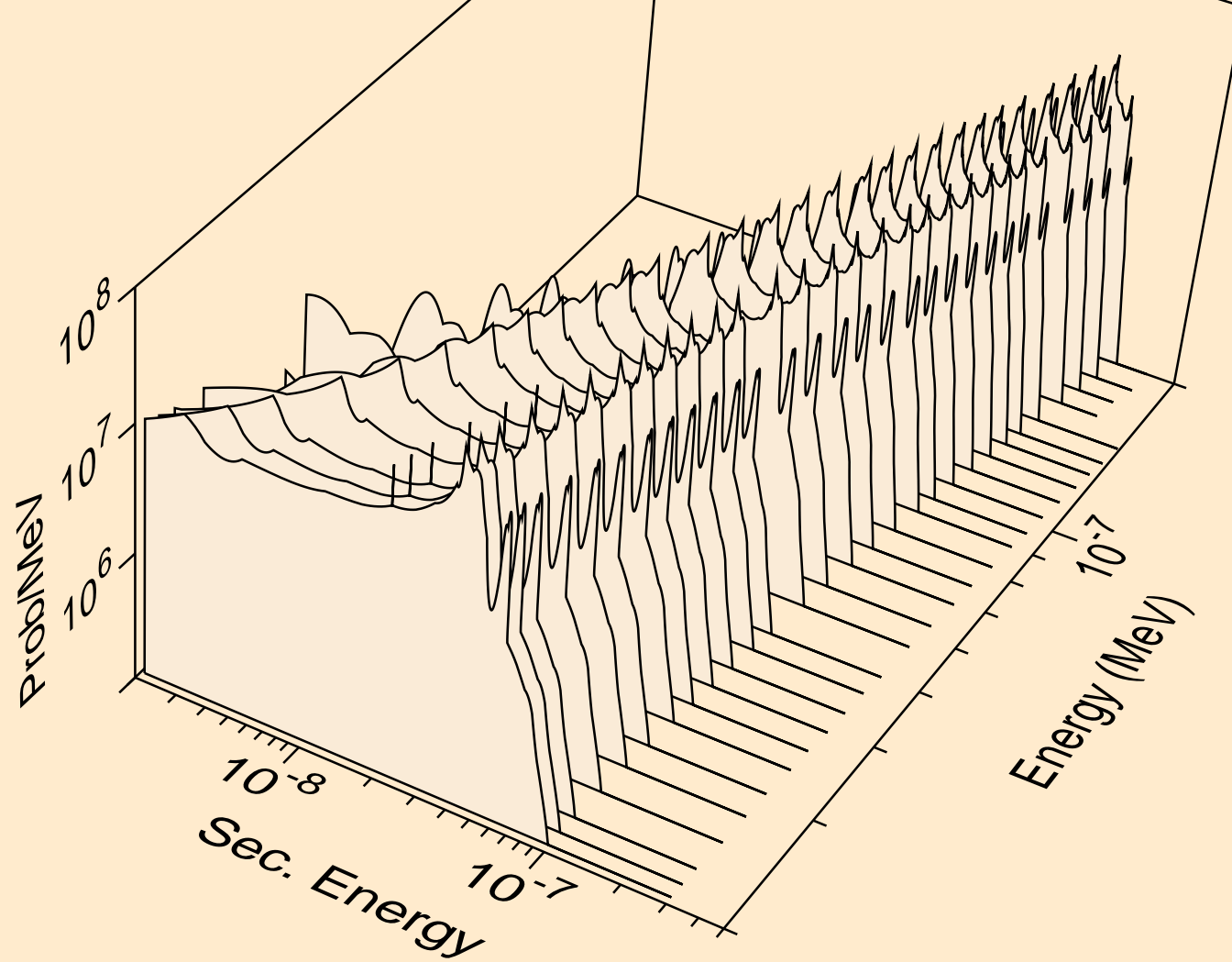

AL-AL_SG225_ALUMINUM @ 293.60K
thermal inelastic

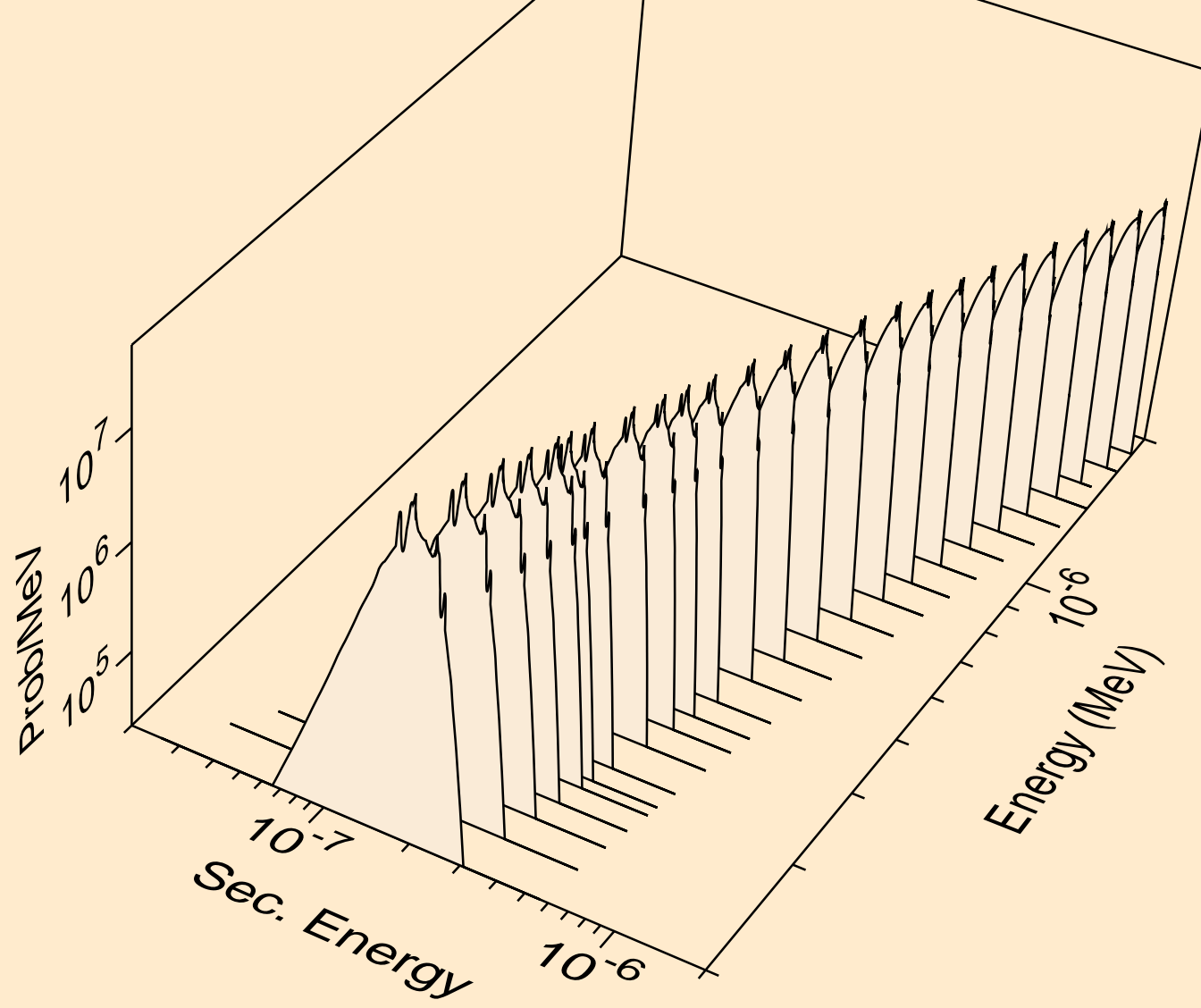

AL-AL_SG225_ALUMINUM @ 293.60K
thermal inelastic

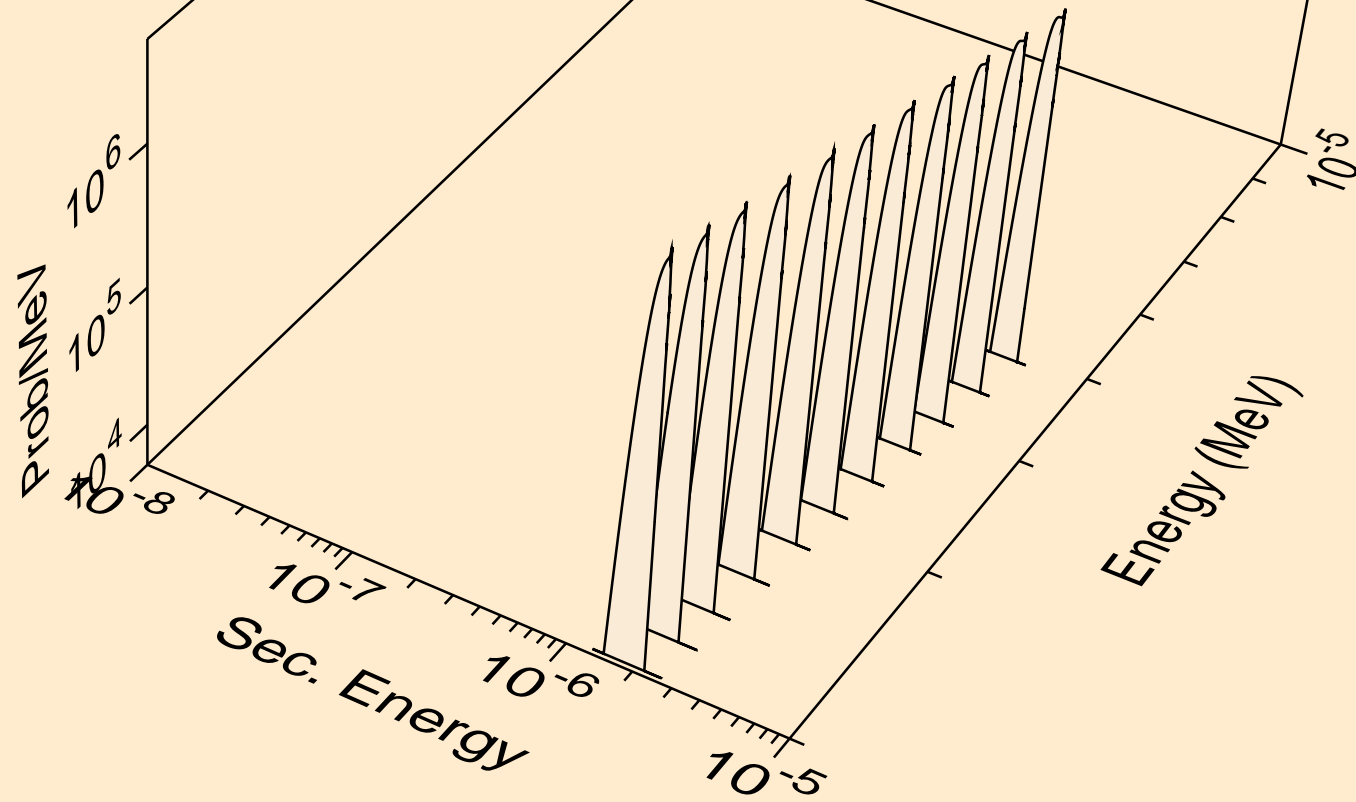

AL-AL_SG225_ALUMINUM @ 293.60K
thermal inelastic for e= 1.012E-09 MeV

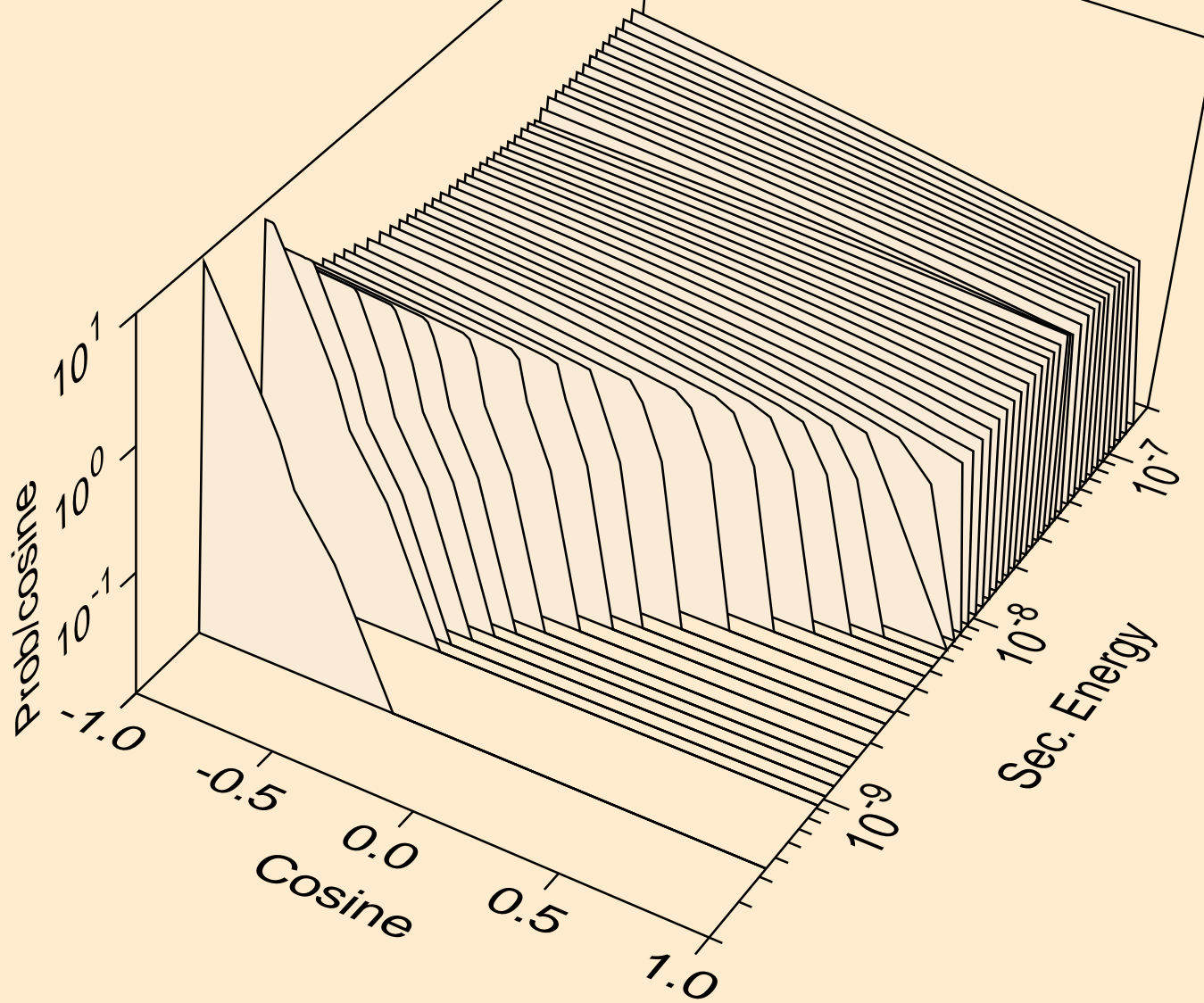

AL-AL_SG225_ALUMINUM @ 293.60K
thermal inelastic for e= 1.417E-08 MeV

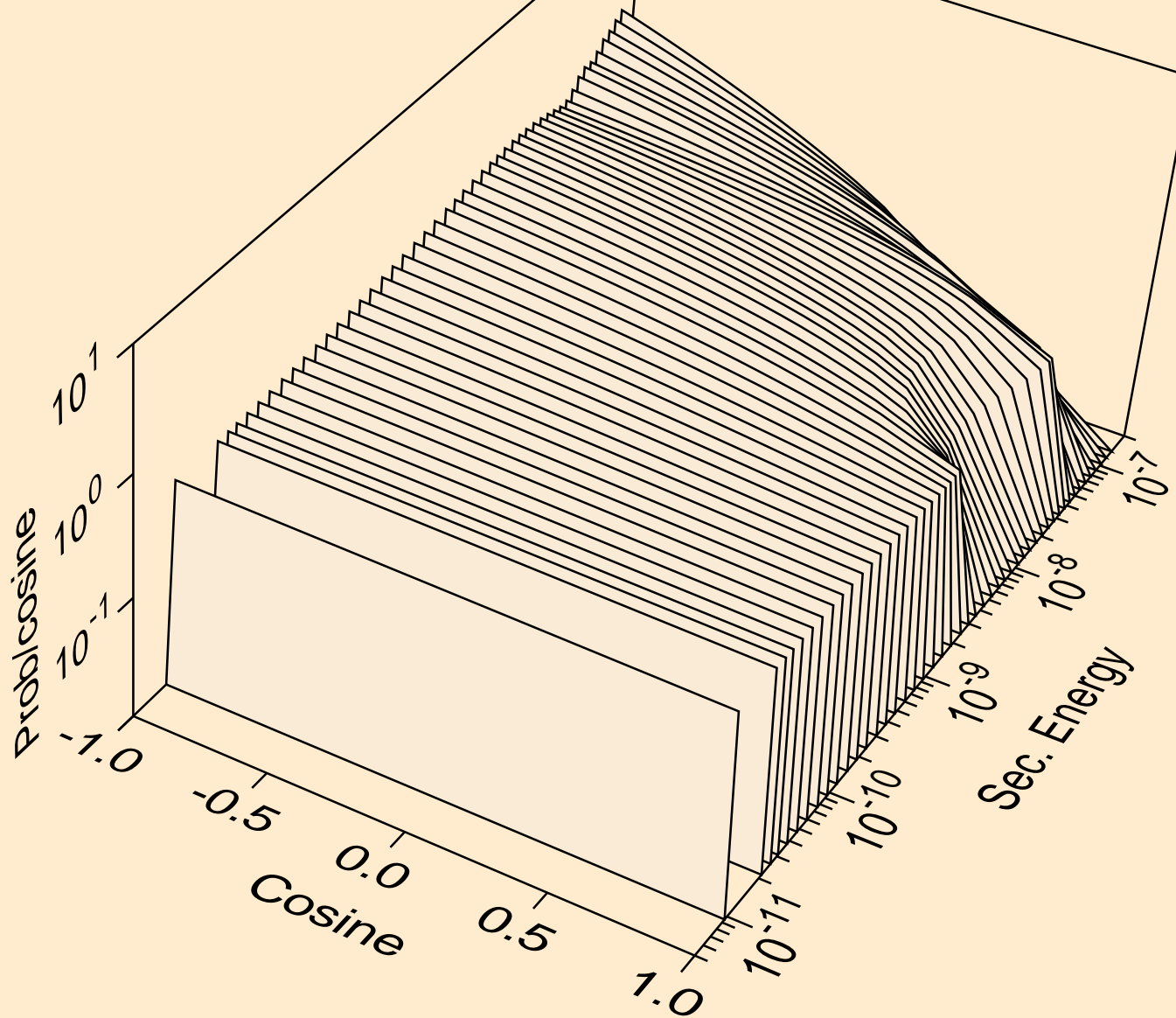

AL-AL_SG225_ALUMINUM @ 293.60K
thermal inelastic for e= 9.000E-08 MeV

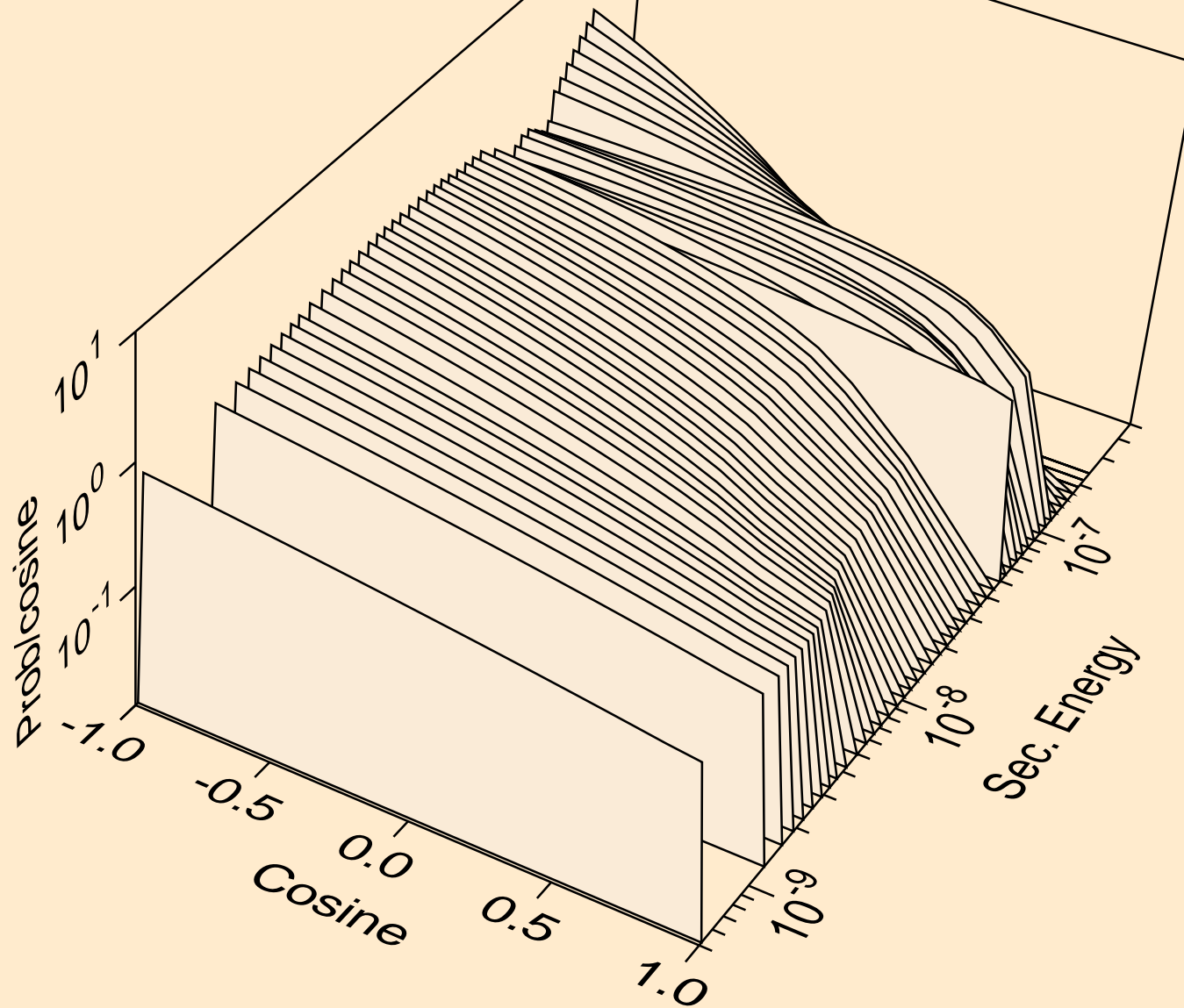

AL-AL_SG225_ALUMINUM @ 293.60K
thermal inelastic for e= 5.033E-07 MeV

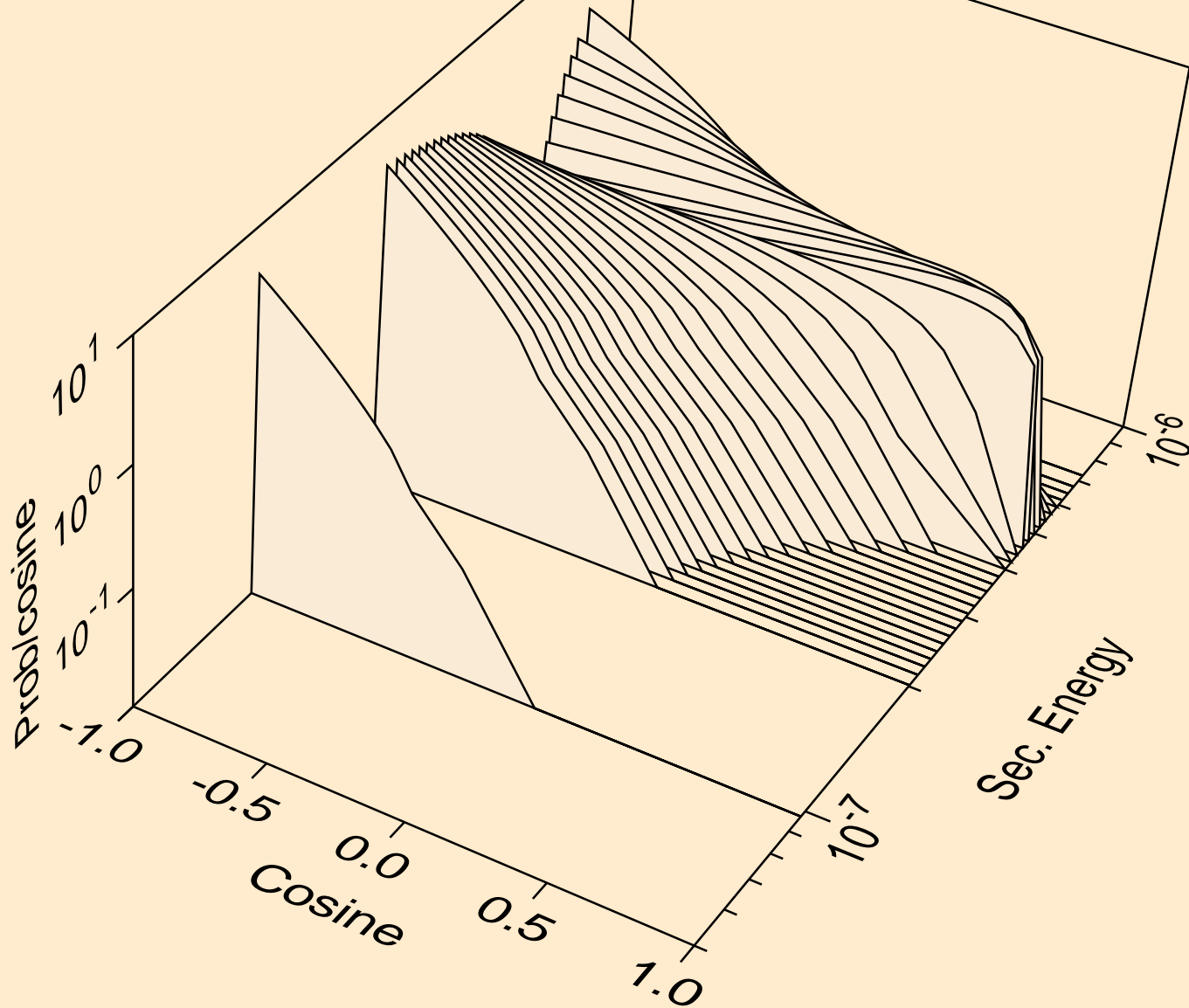

AL-AL_SG225_ALUMINUM @ 293.60K
thermal inelastic for e= 4.070E-06 MeV

