

ELOC 3.0

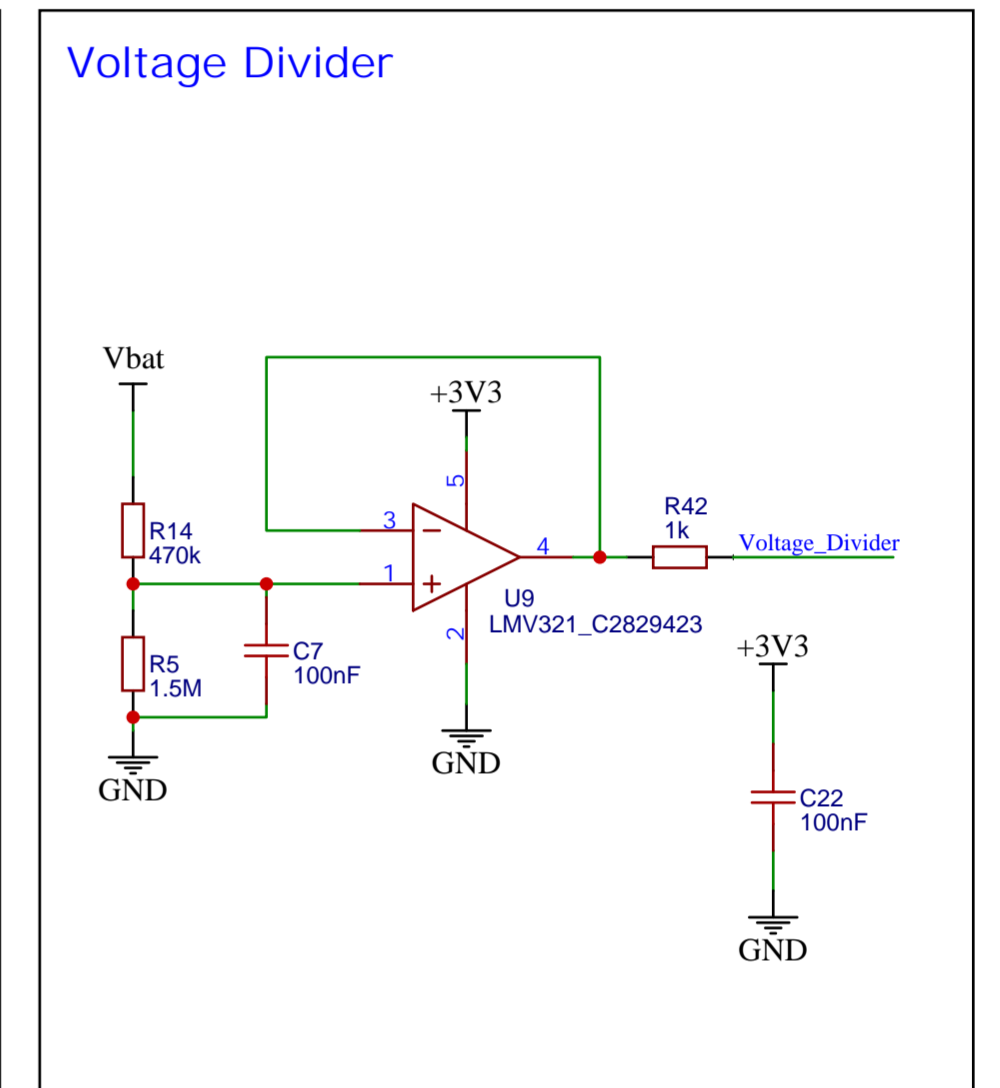

BATTERY MANAGEMENT

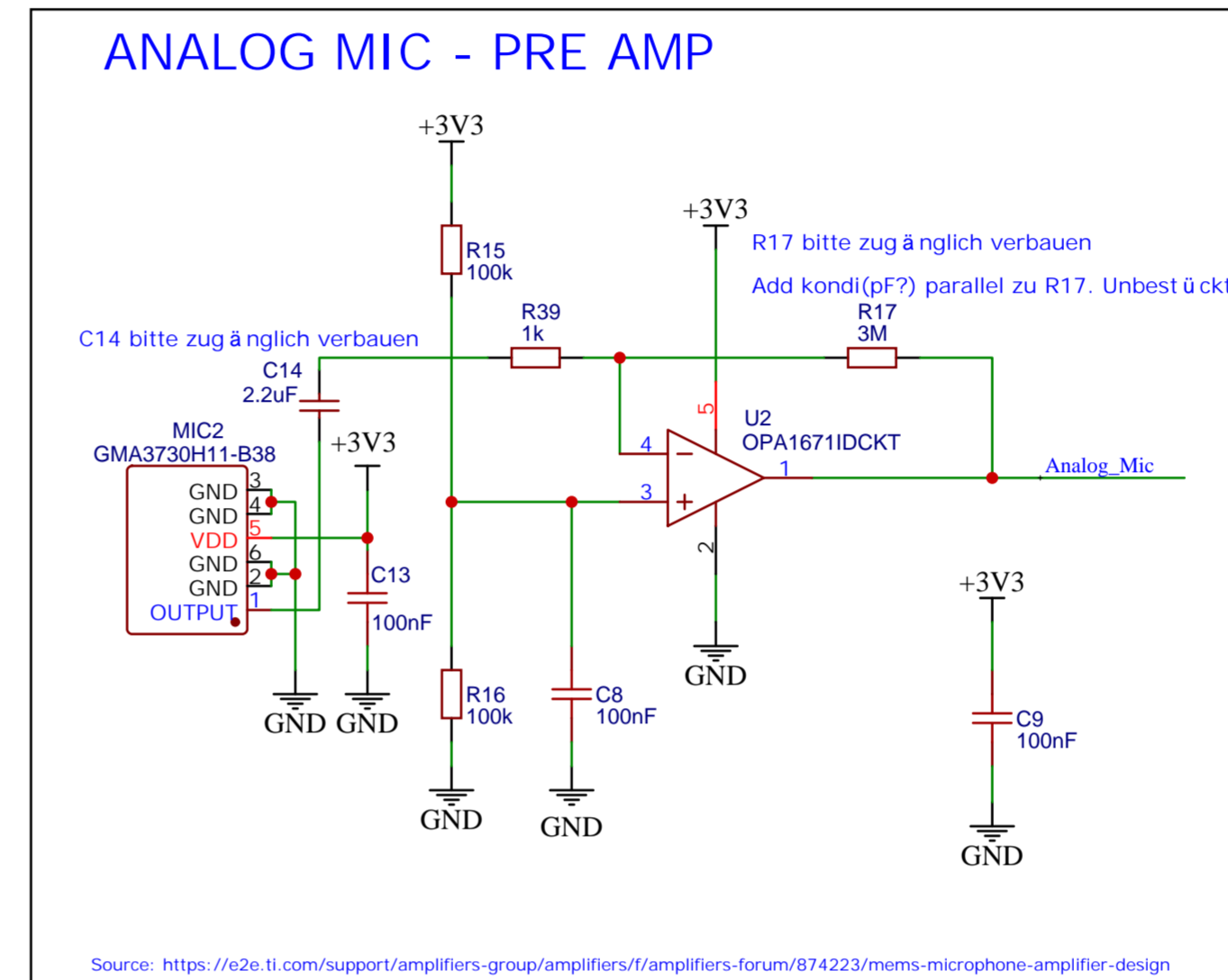
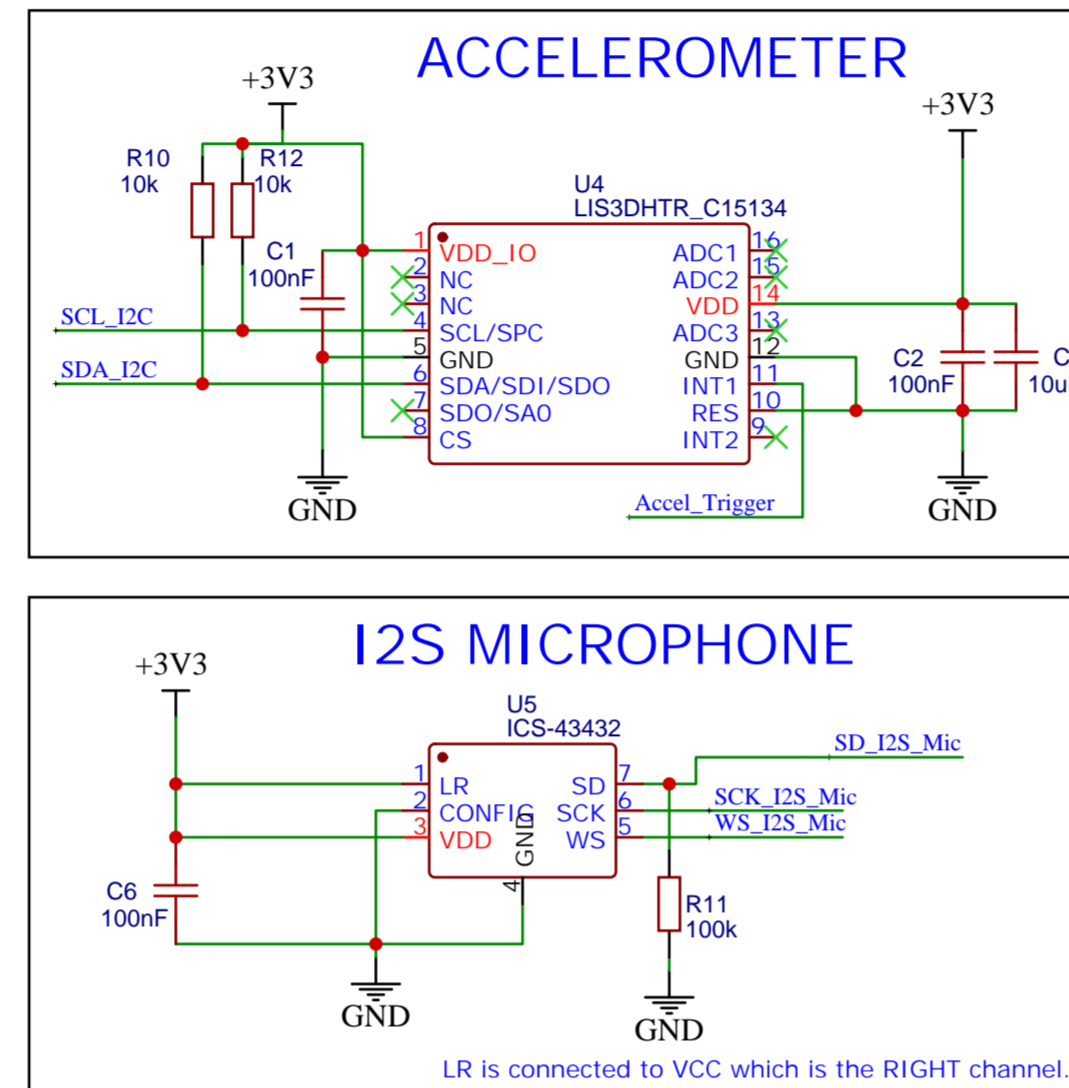
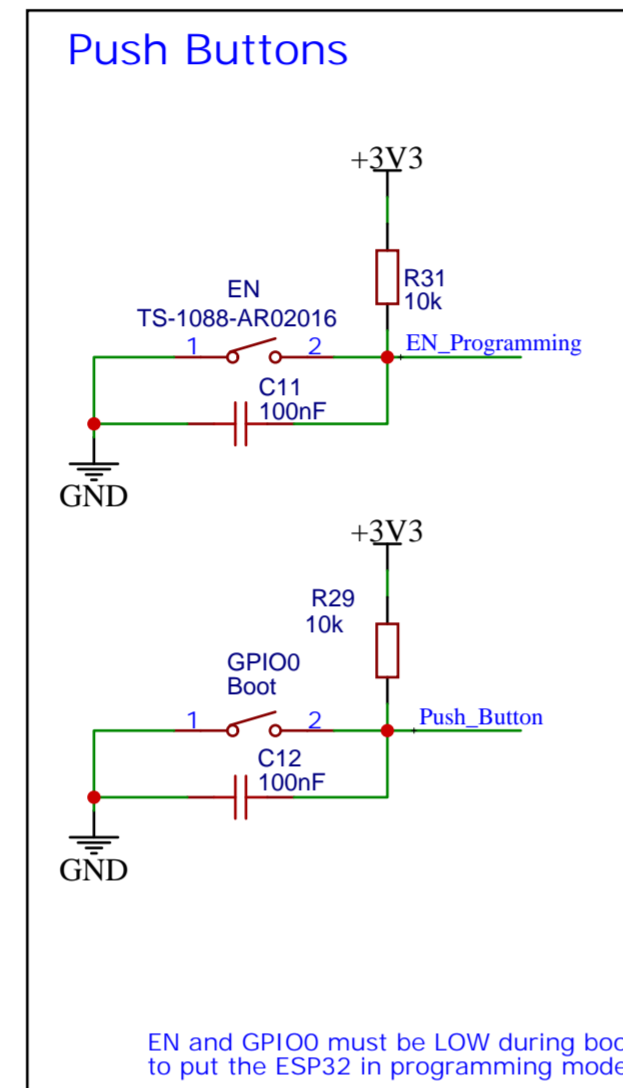
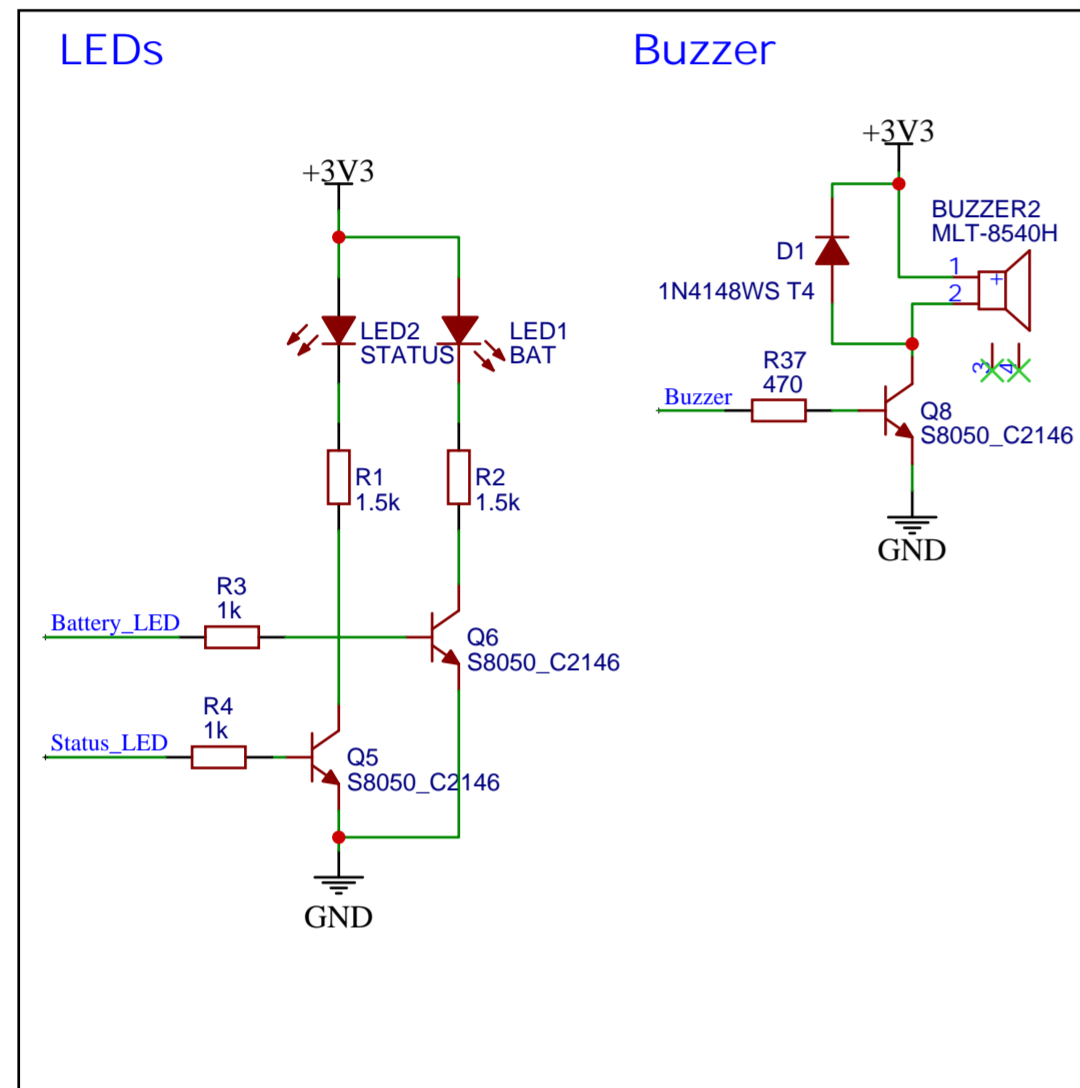
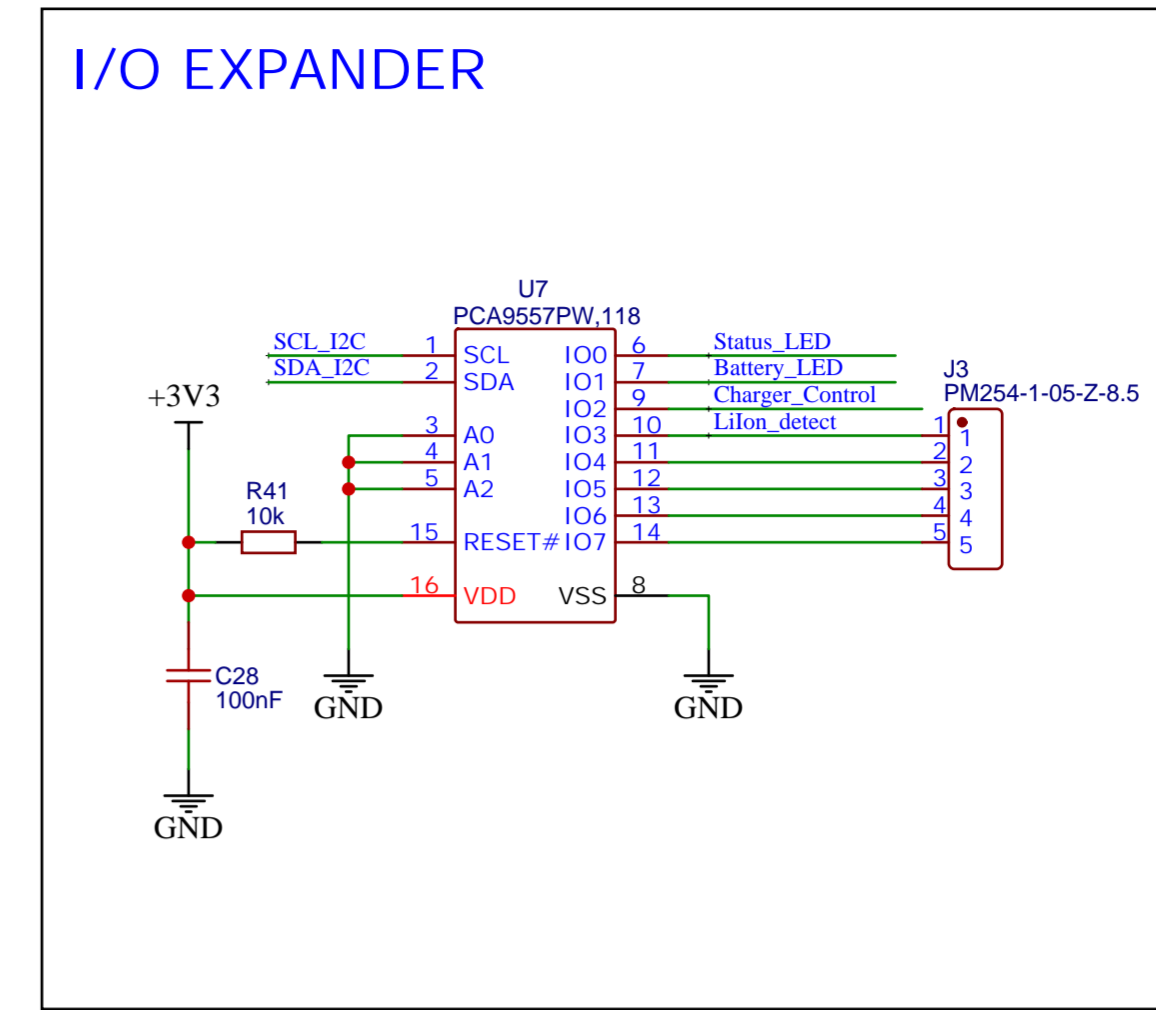
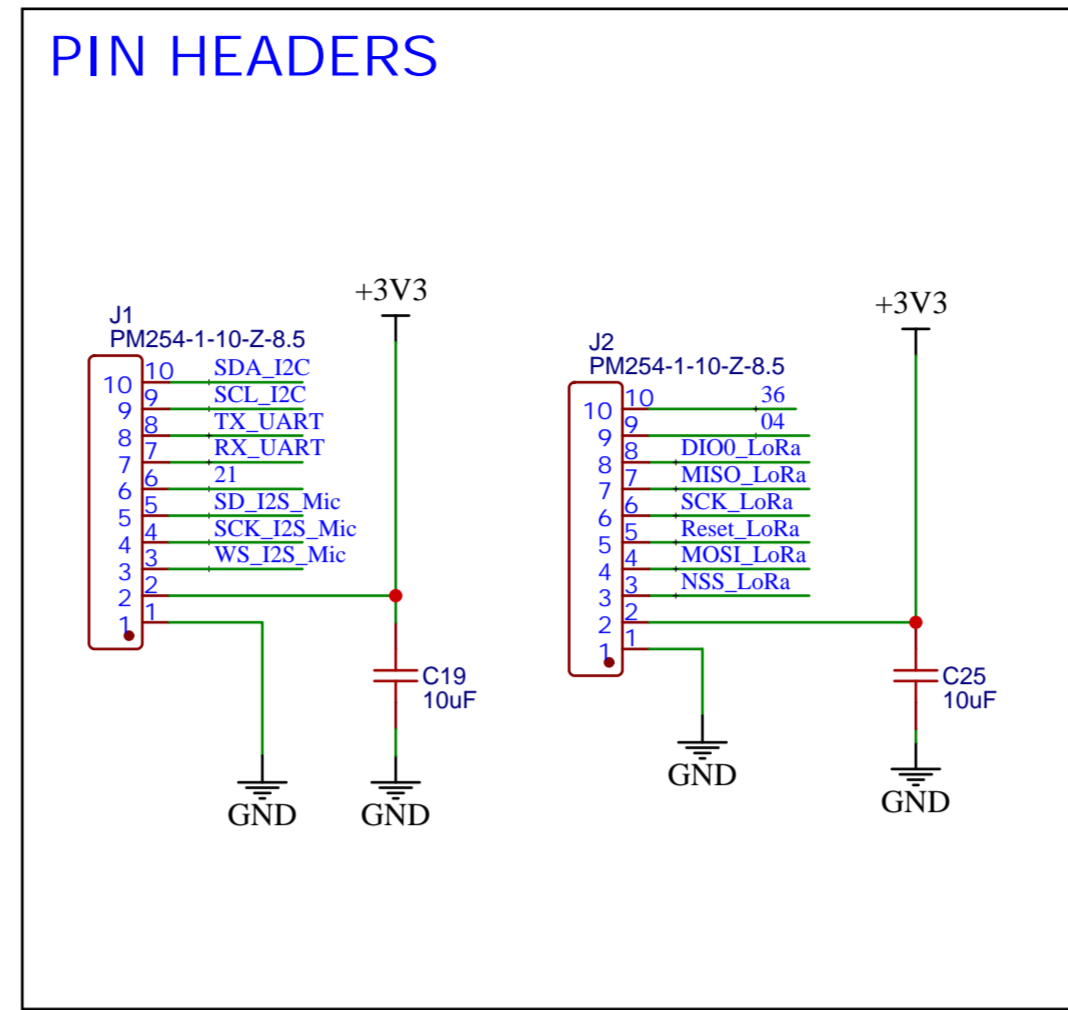
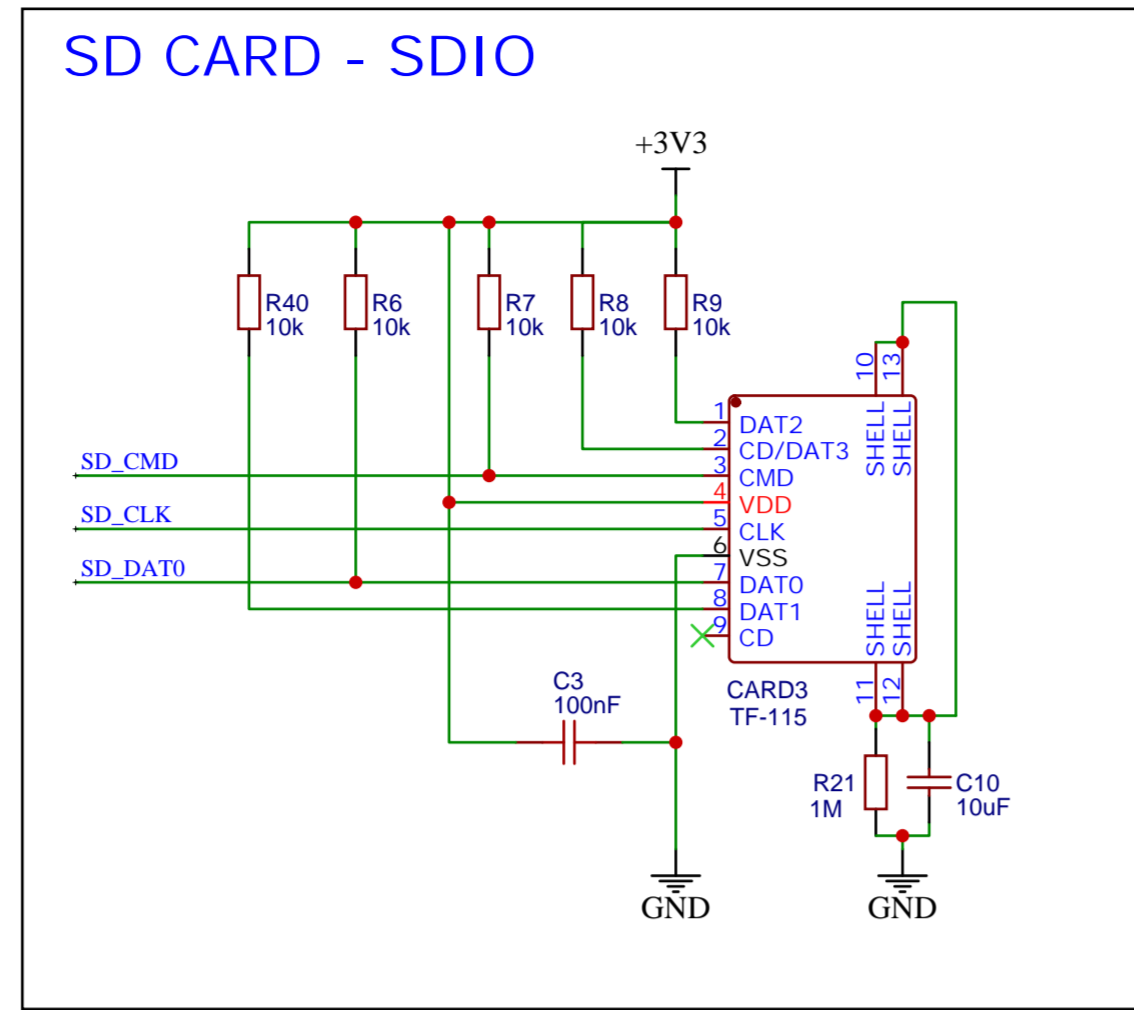
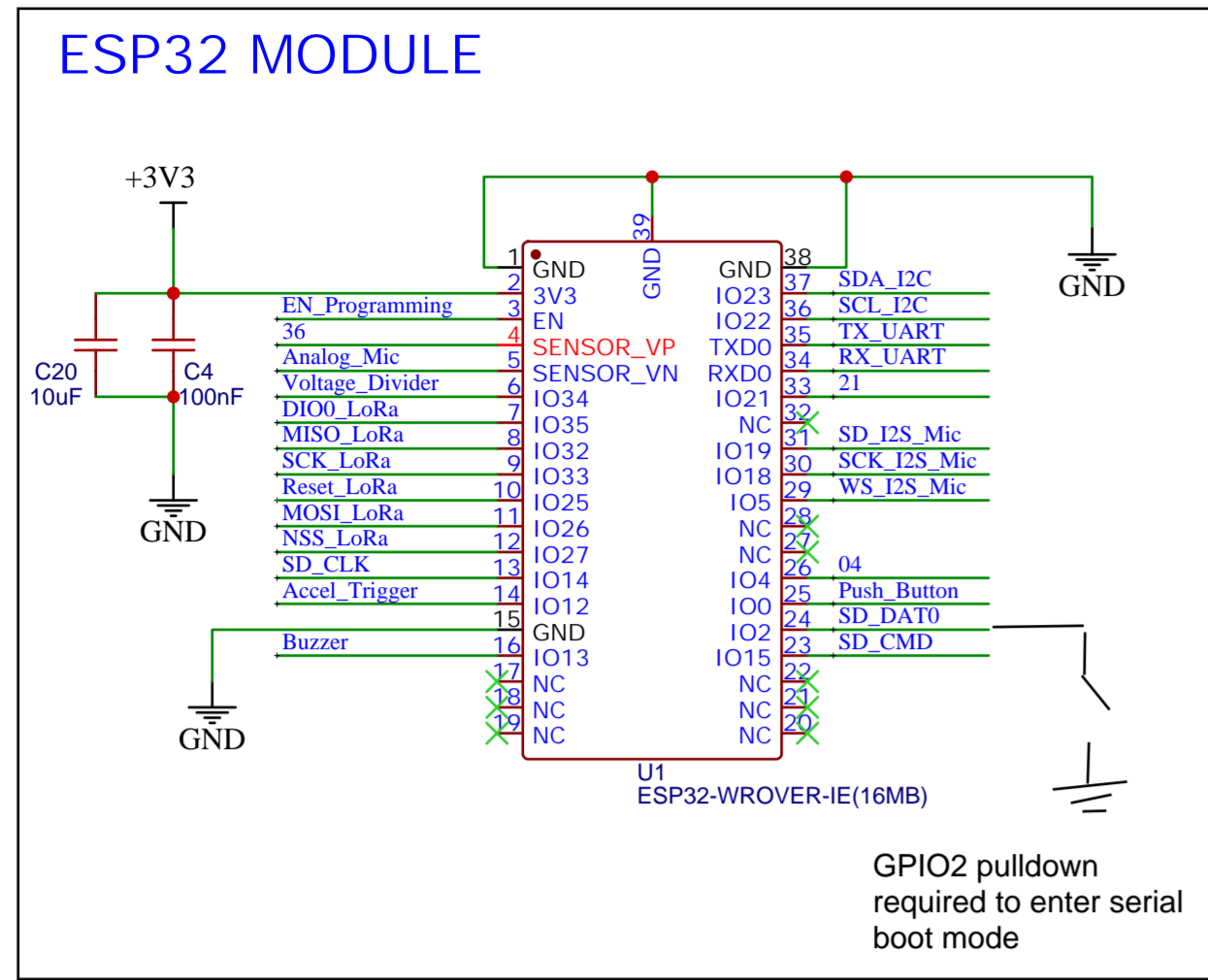
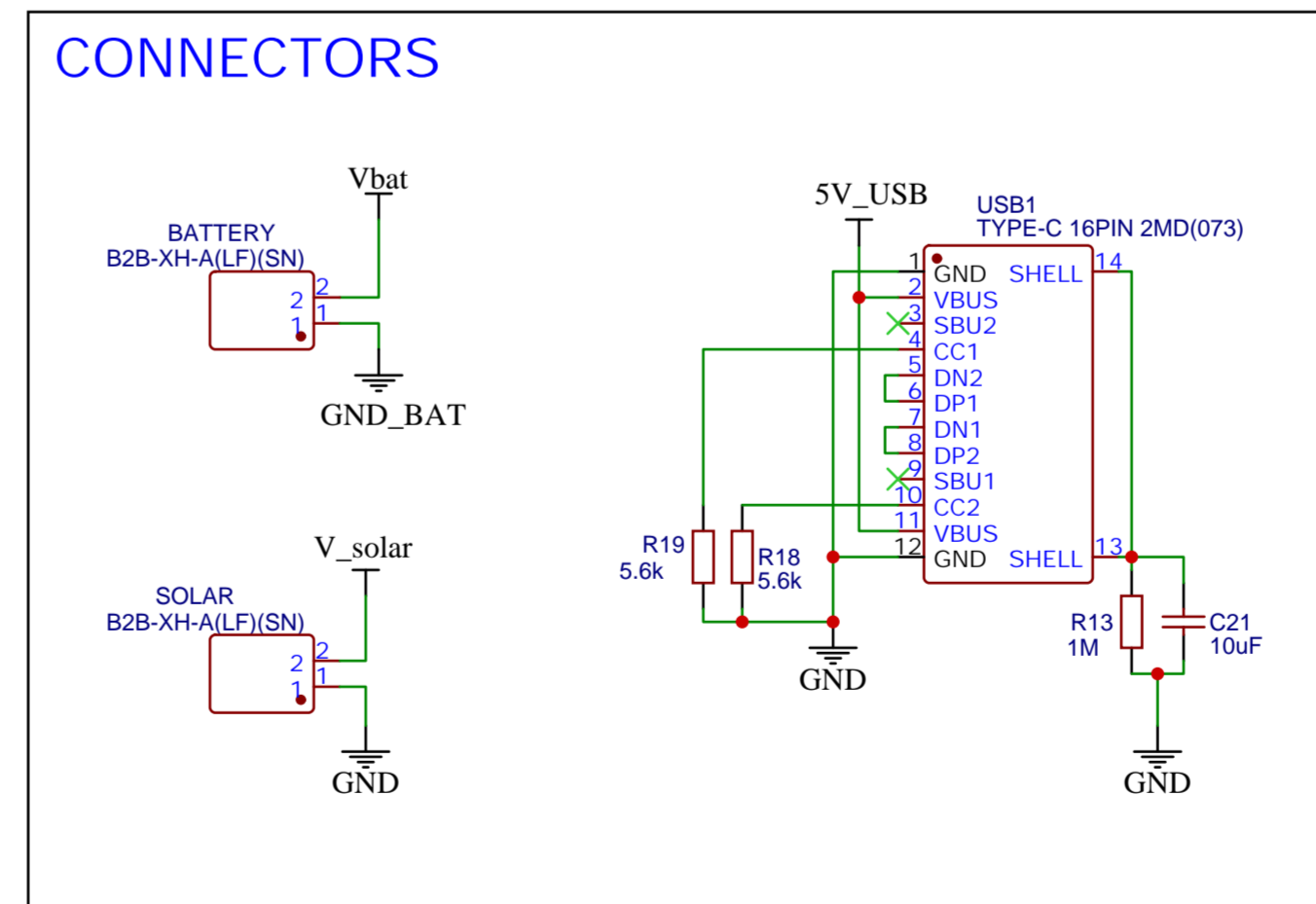
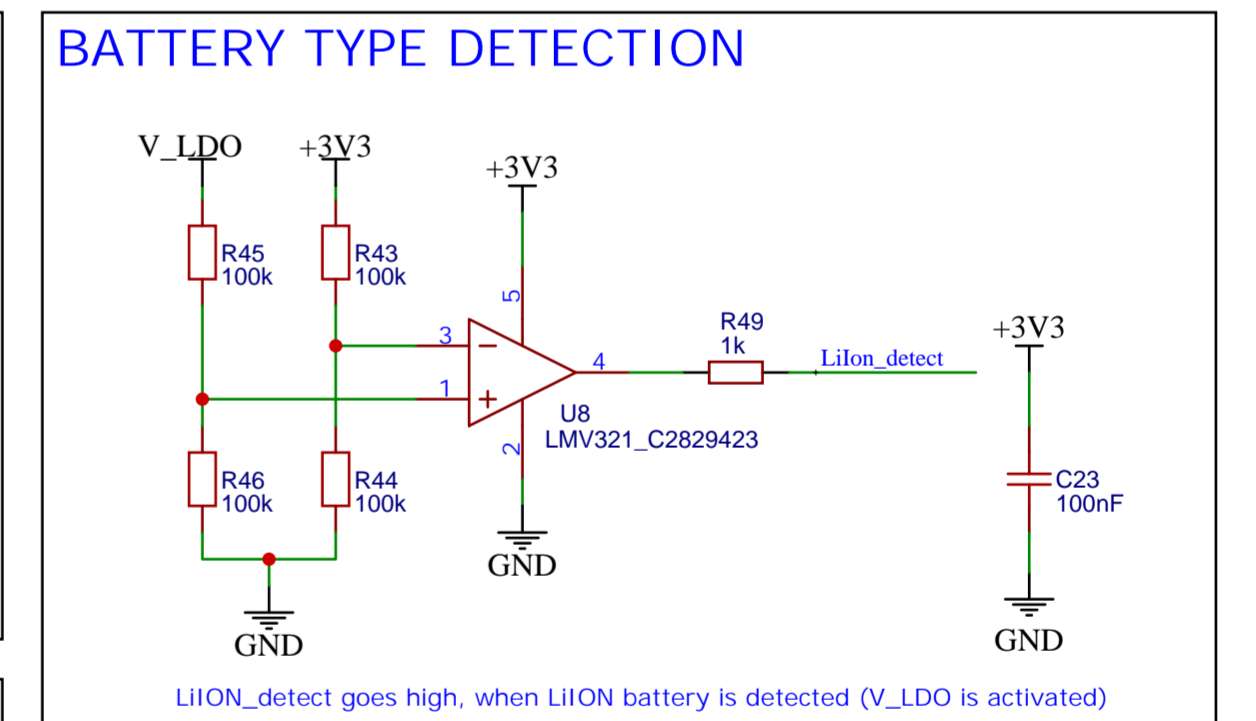
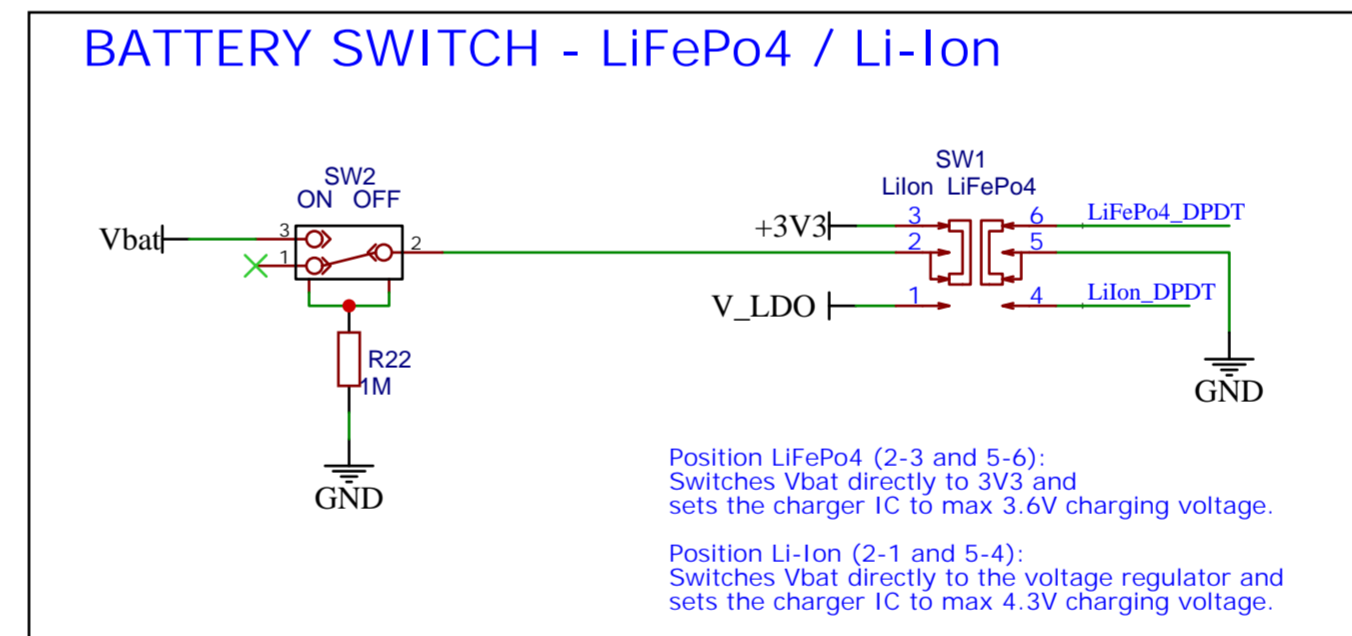
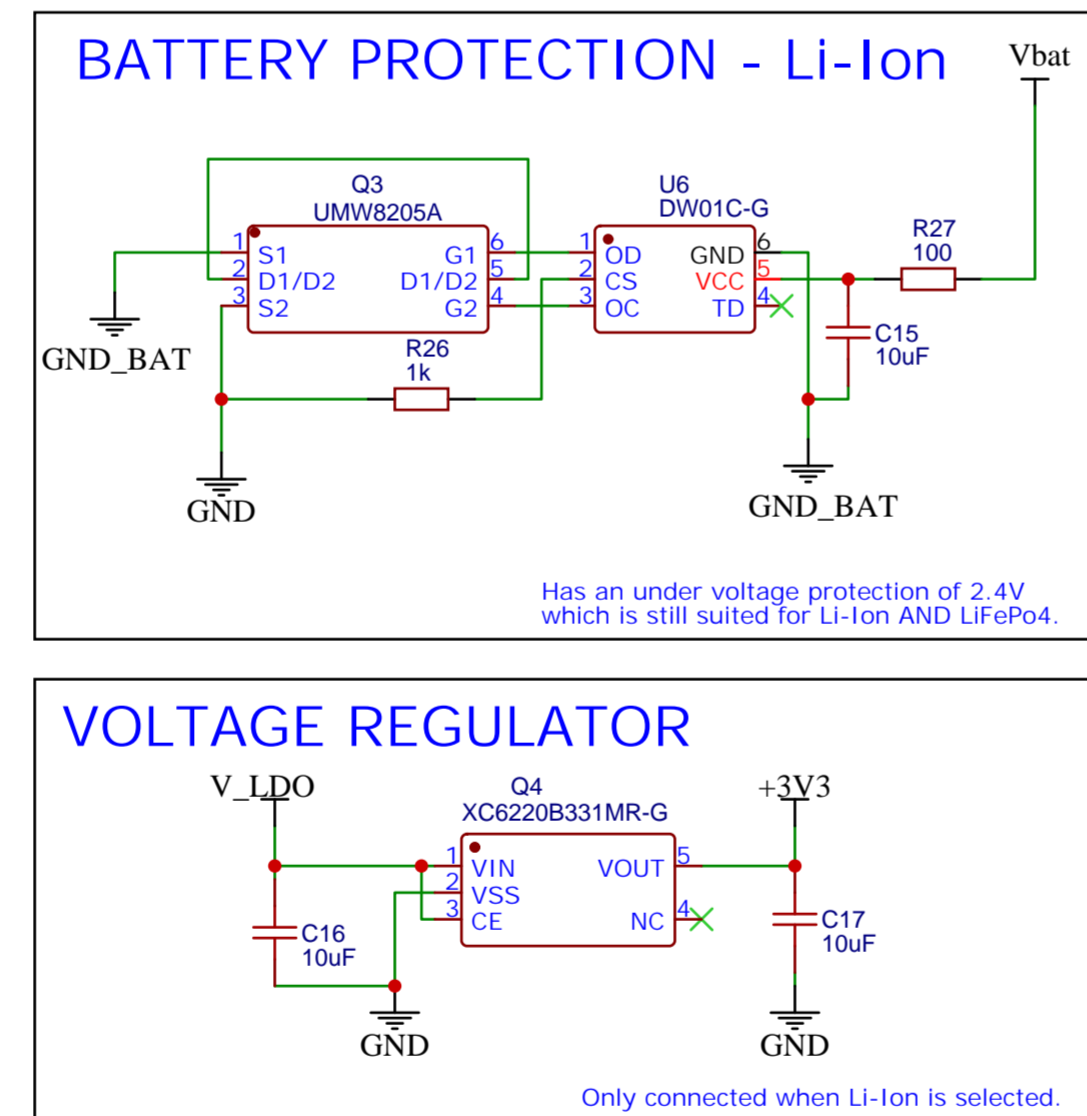
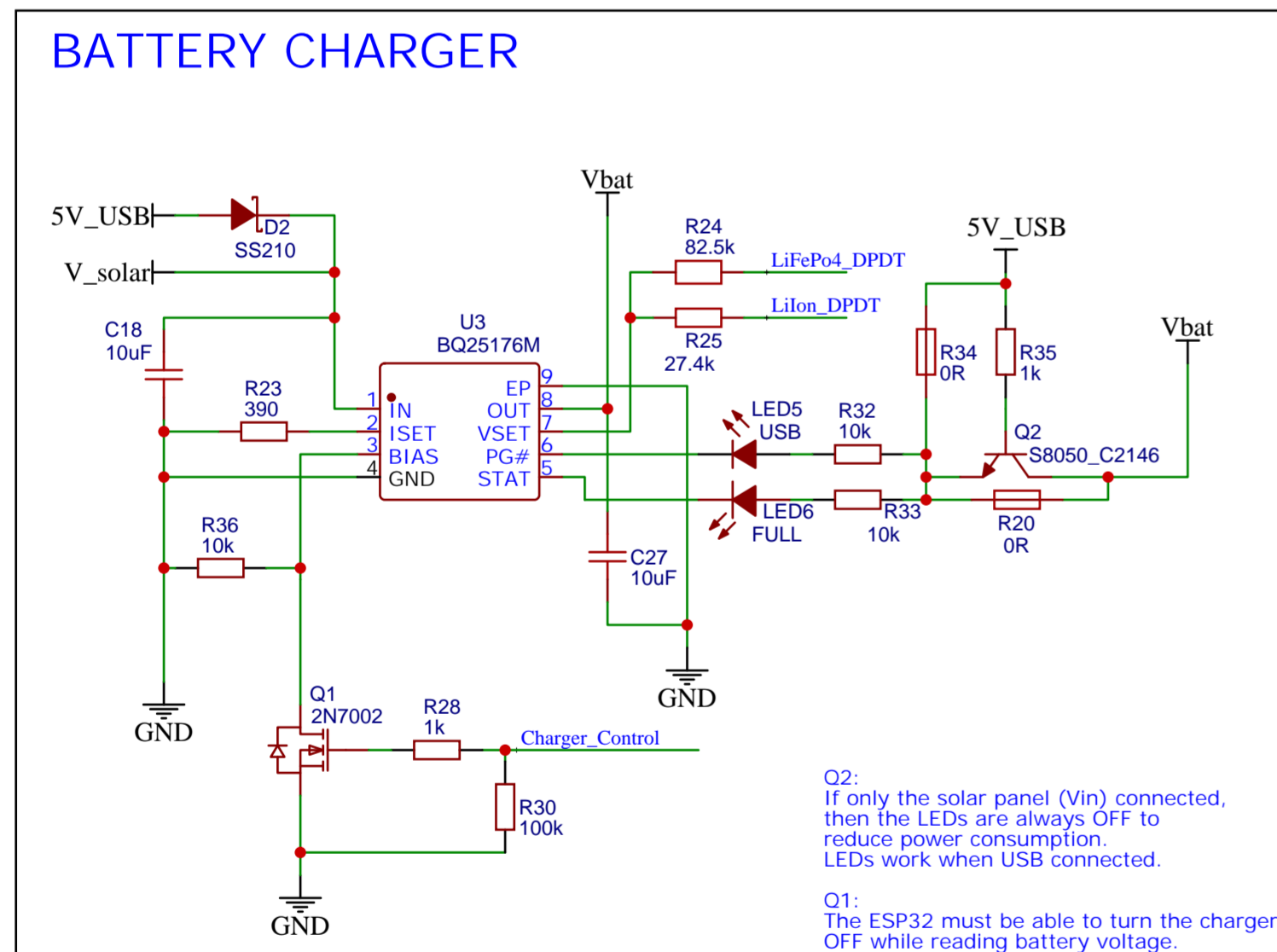

Notes:
Charger IC has overvoltage protection for LiFePo and Li-ion (selectable via DPDT switch).
The charger protection DW01 has over current protection and undervoltage which triggers at 2.4V.
That works for LiFePo4 AND Li-Ion.