

PAW3220LU-TJDU: Ultra-Low Power Wireless Mouse Sensor

General Description

The PixArt PAW3220LU-TJDU is an ultralow power and small form factor optical sensor which is optimized for infrared LED based wireless mouse applications. It has high accuracy navigation ability, low power architecture and automatic power management which make it suitable for power-sensitive application such as wireless mouse. The PAW3220LU-TJDU is capable of high-speed motion detection up to the velocity of 30 inches/sec and acceleration of 10g. In addition, it has an on-chip oscillator and a built-in programmable LED current driver. In order to achieve the best tracking performance, it is recommended to match the sensor with infrared SMT LED (LITE-ON LTE-C216-P-W) and PNSR-015-RB3 optical lens.

Key Features

- Single power with wide voltage range of Low Voltage and High Voltage segments
- Selectable 8-bit (default) or 12-bit motion data length for Delta_X and Delta_Y
- Selectable resolution up to ~1800cpi (based on PNSR-015-RB3 lens)
- Motion detection interrupt output
- Tracking speed up to 30ips (inches/sec) and 10g acceleration
- Built-in Low Power Timer (LPT) for Sleep1/ Sleep2/ Sleep3(1) mode
- Adaptive frame rate control for extra power saving during moving at different speeds
- Programmable LED Current Source (4-bits with 1mA/step) to provide LED with constant current

Applications

- Corded and cordless gaming mice
- Motion input devices

Key Parameters

Parameter	Value
Operating Temperature (°C)	T _A : 0 to +40
Interface	3-Wire SPI
Supply Voltage (V)	Low Voltage Segment: 1.7 - 2.1 High Voltage Segment: 2.1 - 3.6V
Average Supply Current (including LED)	@ VDD = 2.2V Run : 0.27mA Sleep1 : 25uA Sleep2 : 10uA Sleep3 : 8uA Power down : 3uA
Resolution (cpi)	1800
Speed (ips)	30
Acceleration (g)	10
Frame Rate (fps)	4000
Light source	Infrared LED (SMT) LITE-ON LTE-C216-P-W
Companion lens	PNSR-015-RB3
Package Size (mm)	5.2 x 3.0 x 1.88

Ordering Information

Part Number	Package Type
PAW3220LU-TJDU	SMD 8-Balls
PNSR-015-RB3	Companion optical lens



For any additional inquiries, please contact us at <http://www.pixart.com/contact.asp>

1.0 Introduction

1.1 Overview

PAW3220LU-TJDU is a high performance and ultra-low power CMOS-processed optical image sensor with integrated digital image process circuits. It is based on an optical navigation technology which measures changes in position by optically acquiring sequential surface images (frames) and mathematically determining the speed, the direction and the magnitude of motion. The displacement X and Y information are available in registers which are accessible through SPI serial interface. A host controller reads and translates the data from the SPI serial interface into RF signals before sending them to the host PC.

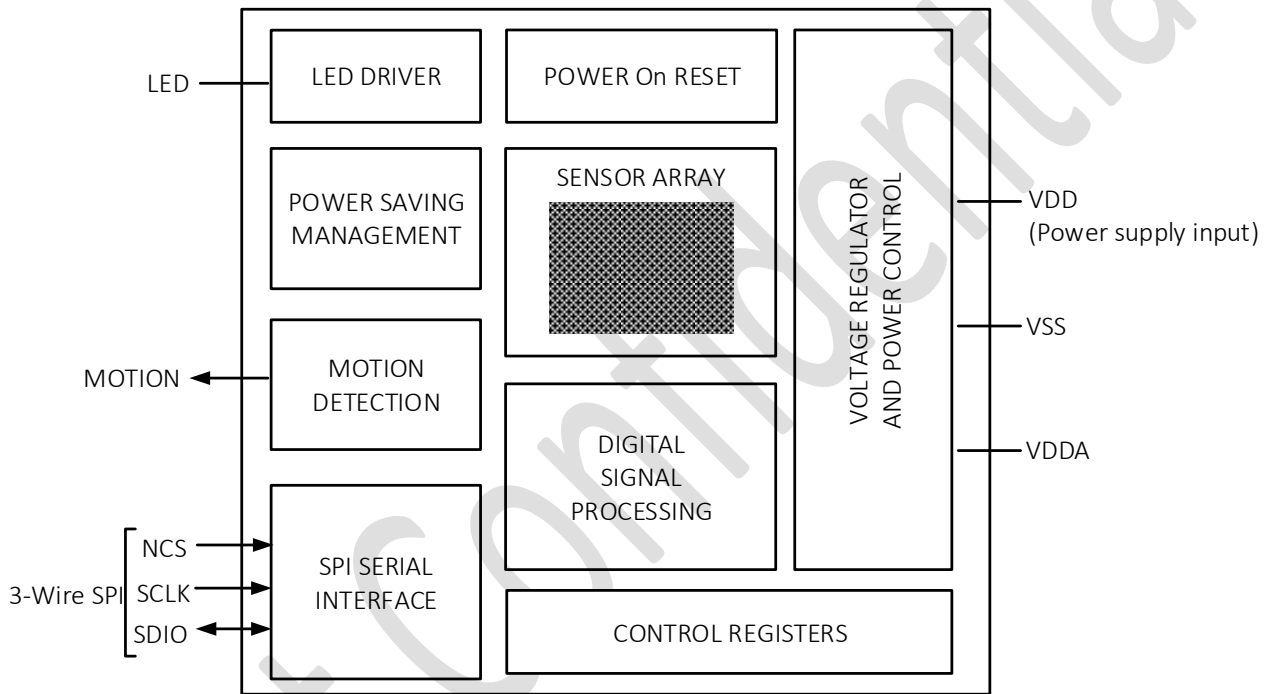

Figure 1. Block Diagram

1.2 Signal Descriptions

Table 1. Signal Pins Description

Pin No.	Signal Name	Type	Description
Functional Group:		Power Supplies	
A1	VDDA	PWR	High Voltage Segment: VDDA is the 1.8V regulator output. Connect to a 4.7uF bypass capacitor. Low Voltage Segment: Connect VDDA directly to VDD.
E3	VDD	PWR	VDD is the power supply input. High Voltage Segment: VDD: 2.1 - 3.6 V Low Voltage Segment: VDD: 1.7 - 2.1 V
VSS	GND	GND	Chip Ground
Functional Group:		SPI Interface	
A3	NCS	Input	Chip Select (Active Low Input)
C3	SDIO	BiDir	Serial Data Input/Output
D2	SCLK	Input	Serial Clock Input
Functional Group:		I/O	
B2	MOTION	Output	Motion Detect (Active Low Output)
E1	LED	Output	LED Illumination Control

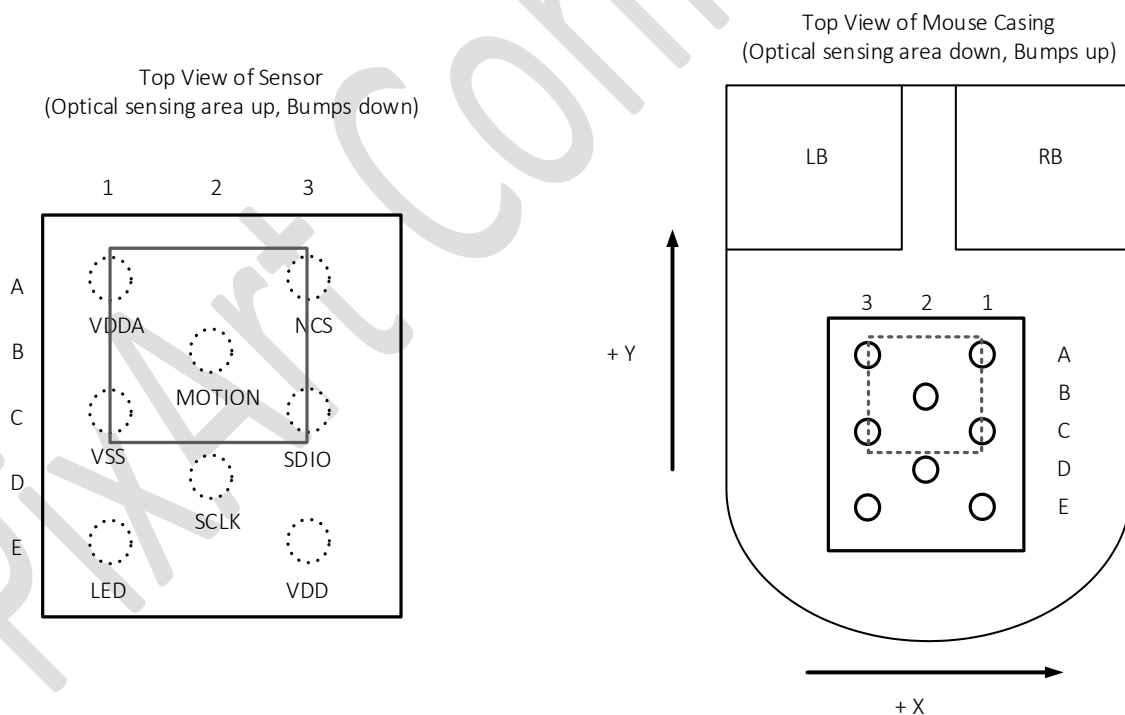

Figure 2. Device Pinout in relation to Orientation of Sensor and Mouse

2.0 Mechanical Specifications

2.1 Package Dimension

Table 2. Package Dimension Specification

Parameters	Symbol	Min.	Typ.	Max.	Unit
Package Body Dimension X	A	1511.1	1536.6	1561.6	μm
Package Body Dimension Y	B	1850.6	1875.6	1900.6	μm
Package Height	C	605	665	725	μm
Ball Height	C1	100	130	160	μm
Package Body Thickness	C2	490	535	580	μm
Thickness of Glass Surface to Wafer	C3	385	405	425	μm
Ball Diameter	D	22	250	280	μm
Total Pin Count	N		8		
Pin Count X-axis	N1		3		
Pin Count Y-axis	N2		5		
Pins Pitch X-axis	J1		440		
Pins Pitch Y-axis	J2		300/600		
Edge to Pin Center Distance along X-axis	S1	298.3	328.3	358.3	μm
Edge to Pin Center Distance along Y-axis	S2	307.8	337.8	367.8	μm

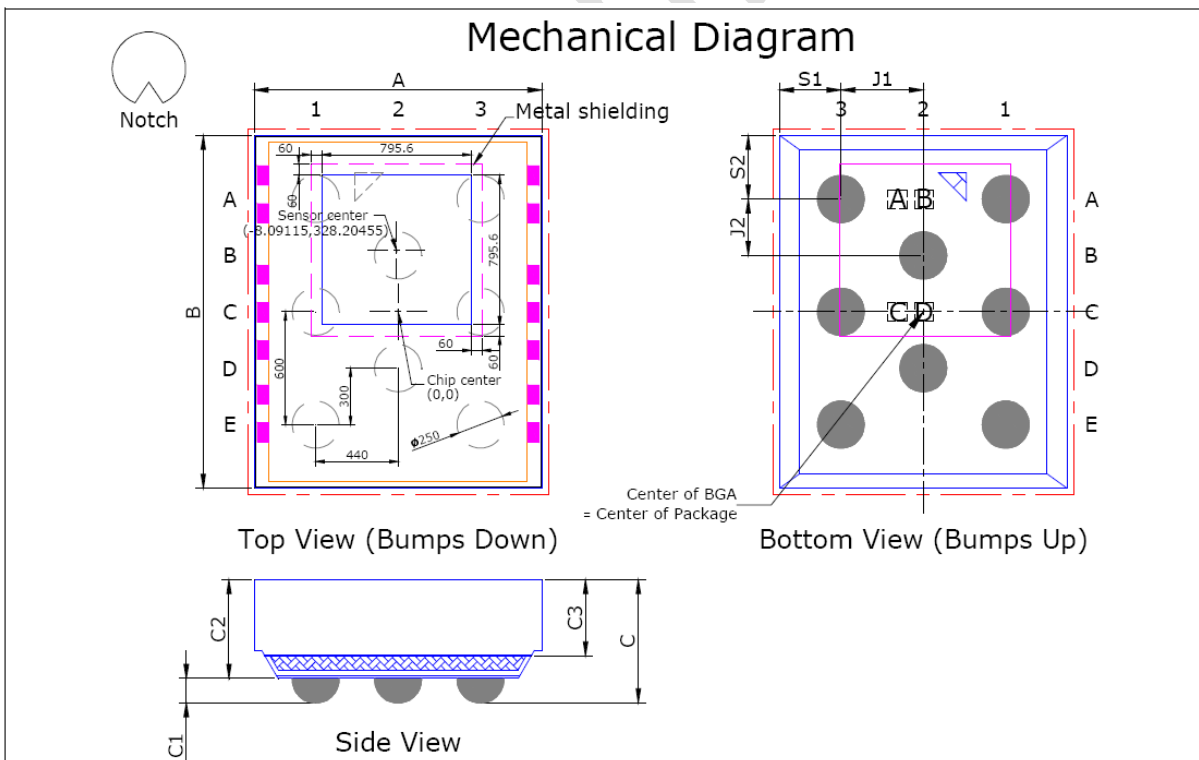

Figure 3. Package Outline Diagram

3.0 System Level Description

3.1 System Overview

To make up a complete system for wireless mouse and battery input device, the device is powered by batteries going through the DC-DC converter to supply power to the PAW3220LU-TJDU sensor, LED and host controller. The sensor is the slave device connecting to a host controller via the 3-wire SPI. The host controller will process the motion data output from the sensor and pass on to the host controller and RF chip. The host controller could also be a RFIC SoC integrated with RF capabilities to signal transmission.

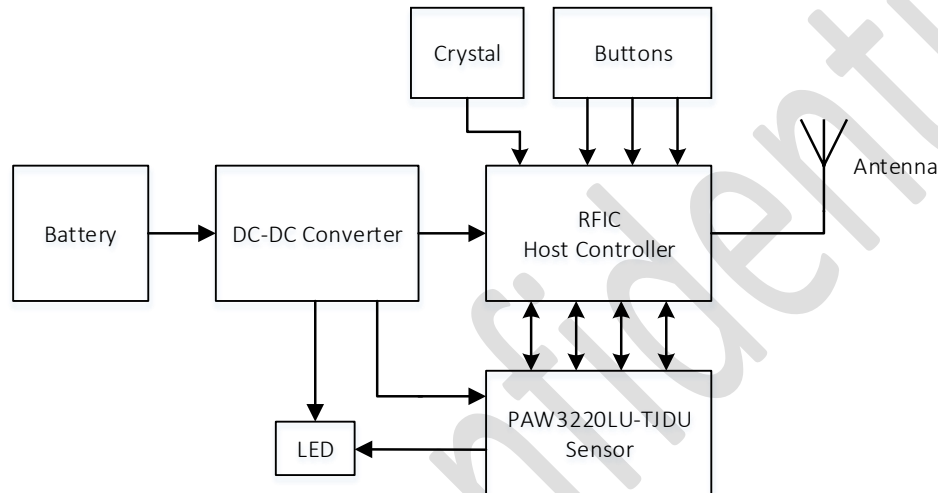

Figure 4. System Block Diagram

3.2 Reference Schematics

The reference circuit in Figure 5 is an example for a wireless IR LED-based mouse application with single AA or AAA battery, a DC/DC output at 2.2V and a Nordic RF IC as a host controller. This example is designed based on the High Voltage Segment configuration (2.1 - 3.6V).

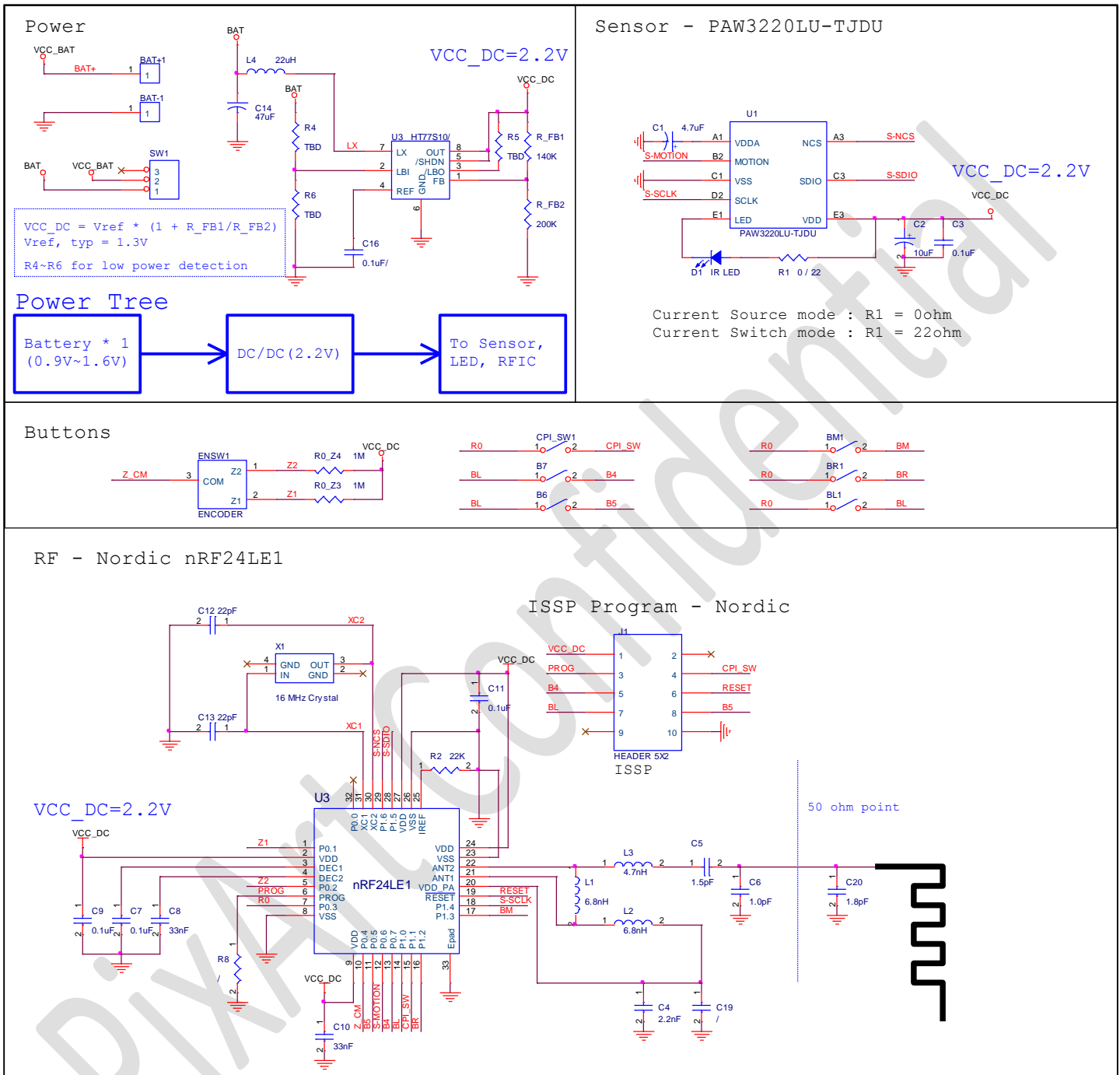

Figure 5. One Battery Application Schematics with DC/DC Output at 2.2V

Document Revision History

Revision Number	Date	Description
1.0	07 May 2015	Initial release

PIXART Confidential