

1.tiff

THE SLEREXE COMPANY LIMITED

SAPORS LANE - BOOLE - DORSET - BH 25 8 ER

TELEPHONE BOOLE (945 13) 51617 - TELEX 123456

Our Ref. 350/PJC/EAC

18th January, 1972.

Dr. P.N. Cundall,
Mining Surveys Ltd.,
Holroyd Road,
Reading,
Berks.

Dear Pete,

Permit me to introduce you to the facility of facsimile transmission.

In facsimile a photocell is caused to perform a raster scan over the subject copy. The variations of print density on the document cause the photocell to generate an analogous electrical video signal. This signal is used to modulate a carrier, which is transmitted to a remote destination over a radio or cable communications link.

At the remote terminal, demodulation reconstructs the video signal, which is used to modulate the density of print produced by a printing device. This device is scanning in a raster scan synchronised with that at the transmitting terminal. As a result, a facsimile copy of the subject document is produced.

Probably you have uses for this facility in your organisation.

Yours sincerely,



P.J. CROSS
Group Leader - Facsimile Research

ETABLISSEMENTS ABCDEFG
 SOCIÉTÉ ANONYME AU CAPITAL DE 300 000 F
 29, RUE DU XVUTRISTE BL F 08000 NTBCLAG
 Tél. : (33) 24.46.32 Adr. Tg. : NRVLJROLM
 Téléx : 31586 F IN : 718400070257
 Transporteur (ou Transitaire)
 M. M. DUPONT Frères
 8 quai des biofish F 0000 NTBCLAG

Not directeur

CLASSEMENT	FACTURE INVOICE	Exemplaire 15	
CODE CLIENT Z 04599	DATE 7-7-74	NUMÉRO 06	FEUILLET 01
Votre commande	du 74-2-2 numéro 438		
Notre offre AZ/B7	du 74-1-1 numéro 12		

LIVRAISON
 5, rue XYZ
 99000 VILLE

FACTURATION
 12, rue ABCD BP 15
 99000 VILLE

DOMICILIATION BANCAIRE DU VENDEUR

PAYS D'ORIGINE PAYS DE DESTINATION

CODE BANQUE CODE GUICHET COMPTE CLIENT
 ORIGINE TRANSPORTS DESTINATION MODE
 Pays 1 Etat 2 Air

CONDITIONS DE LIVRAISON DATE 74-03-03
 LICENCE D'EXPORTATION NATURE DU CONTRAT (monnaie)
 CONDITIONS DE PAIEMENT FAB (échéance, %...)

MARQUES ET NUMÉROS MARKS AND NUMBERS		NOMBRE ET NATURE DES COLIS : DÉNOMINATION DE LA MARCHANDISE NUMBER AND KING OF PACKAGES: DESCRIPTION OF GOODS		NOMEN- CLATURE STATISTICAL No.	MASSE NETTE NET WEIGHT MASSE BRUTE GROSS WEIGHT	VALEUR VALUE DIMENSIONS MEASURE- MENTS
74.21.456.44.2 A		1 Composants		U 123/4	5 kg 8 kg	1400 X 13x10x6
QUANTITÉ COMMANDÉE ET UNITÉ QUANTITY ORDERED AND UNIT	N° ET RÉF. DE L'ARTICLE	DÉSIGNATION		QUANTITÉ LIVRÉE ET UNITÉ QUANTITY DELIVERED AND UNIT	PRIX UNITAIRE UNIT PRICE	MONTANT TOTAL TOTAL AMOUNT
2	AF-809	Circuit intégré		2	104,33 F	208,66 F
10	S8-T4	Connecteur		10	83,10 F	831,00 F
25	ZIO7	Composant indéterminé		20	15,00 F	300,00 F

Coûts	Débours	Inclus	Non inclus
Packing	Emballages		92,14
Freight	Transport		
Insurance	Assurances		
Total invoice amount	Montant total de la facture		1431,80
Installment	Acomptes		
NET TO BE PAID	NET A RÉGLER		1431,80

A

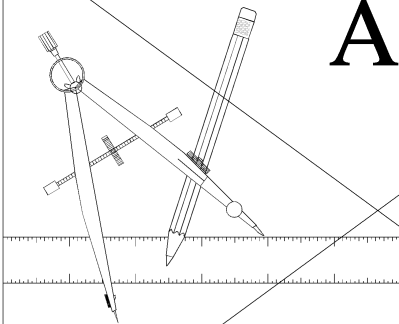

Kofax Test Image

Kofax test print 30pt Bold Italic

Kofax test print 24pt CGTimes Bold

Kofax test print 18pt CGTimes

Kofax test print 18pt Park Avenue

Kofax test print 12pt CGTimes

Kofax test print 10pt CGTimes Italic

Kofax test print 8pt Univers

Kofax test print 6pt Univers Italic

Kofax has gone to lengths

This page was created with Aldus PageMaker® and the
Kofax MS-Windows 3.0 QuickPrint Printer Driver.

A complex form or document with various fields and text. It appears to be a test print or a form for data entry. The form is titled '11040' and contains several sections with checkboxes and text boxes. The text is small and difficult to read, but it seems to be a standard form used in a technical or administrative context.

Kofax Image Products.
3 Jenner St.
Irvine, CA 92718
TEL: (714)-727-1733
FAX: (714)-727-3144

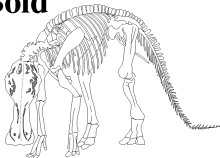

12 pt

Incidunt nesciunt ratione est fuga ea voluptatem. Ab natus qui perferendis molestiae doloremque. Esse enim repellat est ab ut. Ut ea ut et et. Consequatur sit saepe et non reprehenderit aspernatur ipsum omnis.

Nihil et quis harum est molestiae. Et at ipsam quod veritatis id accusantium quidem itaque. Facilis earum numquam ipsam consequatur et nihil distinctio non.

Repellat alias magni sunt nisi ipsam dolores. Ut ut eius quia maxime est dolorum distinctio. Assumenda libero rerum et itaque dolorum. Explicabo odit explicabo necessitatibus adipisci in voluptatibus. In id voluptatem delectus et aliquam. Consequuntur velit aut occaecati in a.

Praesentium quisquam sint suscipit. Quis dolore eos nisi enim doloribus. Quidem non quo dolor.

Et nisi aut quam explicabo. Non dolore omnis corrupti numquam dolorem sequi aut. Odio veniam quae est. Ullam similique asperiores a aut. Sapiente deleniti totam suscipit.

10 pt

Incidunt nesciunt ratione est fuga ea voluptatem. Ab natus qui perferendis molestiae doloremque. Esse enim repellat est ab ut. Ut ea ut et et. Consequatur sit saepe et non reprehenderit aspernatur ipsum omnis.

Nihil et quis harum est molestiae. Et at ipsam quod veritatis id accusantium quidem itaque. Facilis earum numquam ipsam consequatur et nihil distinctio non.

Repellat alias magni sunt nisi ipsam dolores. Ut ut eius quia maxime est dolorum distinctio. Assumenda libero rerum et itaque dolorum. Explicabo odit explicabo necessitatibus adipisci in voluptatibus. In id voluptatem delectus et aliquam. Consequuntur velit aut occaecati in a.

Praesentium quisquam sint suscipit. Quis dolore eos nisi enim doloribus. Quidem non quo dolor.

Et nisi aut quam explicabo. Non dolore omnis corrupti numquam dolorem sequi aut. Odio veniam quae est. Ullam similique asperiores a aut. Sapiente deleniti totam suscipit.

5/
3
€
©
Σ
Ω



$$8 \sqrt{E=mc^2 f(x) = \sum_{m=0}^{\infty} \frac{f^{(m)}(0)}{m!} x^m} \sqrt{9} \in 7$$

Passive Activity Loss Limitations

Department of the Treasury
Internal Revenue Service (99)

^a See separate instructions.
^a Attach to Form 1040 or Form 1041.

2011
Attachment
Sequence No. **88**

Name(s) shown on return
MARTIN KRAFFT

Identifying number
948-73-0851

Part I 2011 Passive Activity Loss

Caution: Complete Worksheets 1, 2, and 3 before completing Part I.

Rental Real Estate Activities With Active Participation (For the definition of active participation, see **Special Allowance for Rental Real Estate Activities** in the instructions.)

1a Activities with net income (enter the amount from Worksheet 1, column (a))	1a			
b Activities with net loss (enter the amount from Worksheet 1, column (b))	1b	()
c Prior years unallowed losses (enter the amount from Worksheet 1, column (c))	1c	()
d Combine lines 1a, 1b, and 1c				1d

Commercial Revitalization Deductions From Rental Real Estate Activities

2a Commercial revitalization deductions from Worksheet 2, column (a)	2a	()
b Prior year unallowed commercial revitalization deductions from Worksheet 2, column (b)	2b	()
c Add lines 2a and 2b				2c ()

All Other Passive Activities

3a Activities with net income (enter the amount from Worksheet 3, column (a))	3a		15,108	
b Activities with net loss (enter the amount from Worksheet 3, column (b))	3b	(1,178)
c Prior years unallowed losses (enter the amount from Worksheet 3, column (c))	3c	()
d Combine lines 3a, 3b, and 3c				3d 13,930

4 Combine lines 1d, 2c, and 3d. If this line is zero or more, stop here and include this form with your return; all losses are allowed, including any prior year unallowed losses entered on line 1c, 2b, or 3c. Report the losses on the forms and schedules normally used	4		13,930	
--	---	--	--------	--

- If line 4 is a loss and:
- Line 1d is a loss, go to Part II.
 - Line 2c is a loss (and line 1d is zero or more), skip Part II and go to Part III.
 - Line 3d is a loss (and lines 1d and 2c are zero or more), skip Parts II and III and go to line 15.

Caution: If your filing status is married filing separately and you lived with your spouse at any time during the year, **do not** complete Part II or Part III. Instead, go to line 15.

Part II Special Allowance for Rental Real Estate Activities With Active Participation

Note: Enter all numbers in Part II as positive amounts. See instructions for an example.

5 Enter the smaller of the loss on line 1d or the loss on line 4	5			
6 Enter \$150,000. If married filing separately, see instructions	6			
7 Enter modified adjusted gross income, but not less than zero (see instructions)	7			
Note: If line 7 is greater than or equal to line 6, skip lines 8 and 9, enter -0- on line 10. Otherwise, go to line 8.				
8 Subtract line 7 from line 6	8			
9 Multiply line 8 by 50% (.5). Do not enter more than \$25,000. If married filing separately, see instructions	9			
10 Enter the smaller of line 5 or line 9	10			

If line 2c is a loss, go to Part III. Otherwise, go to line 15.

Part III Special Allowance for Commercial Revitalization Deductions From Rental Real Estate Activities

Note: Enter all numbers in Part III as positive amounts. See the example for Part II in the instructions.

11 Enter \$25,000 reduced by the amount, if any, on line 10. If married filing separately, see instructions	11			
12 Enter the loss from line 4	12			
13 Reduce line 12 by the amount on line 10	13			
14 Enter the smallest of line 2c (treated as a positive amount), line 11, or line 13	14			

Part IV Total Losses Allowed

15 Add the income, if any, on lines 1a and 3a and enter the total	15			
16 Total losses allowed from all passive activities for 2011. Add lines 10, 14, and 15. See instructions to find out how to report the losses on your tax return	16			

First system of a piano score. The right hand features a melodic line with eighth-note patterns, while the left hand provides a steady accompaniment of quarter notes. The key signature has one sharp (F#).

Second system of the piano score. It includes dynamic markings: *dim.* (diminuendo), *p* (piano), and *f marc. espr.* (forte marcato, espressivo). The left hand has a *p* marking. The system concludes with a double bar line and a repeat sign.

Third system of the piano score. The right hand has a first ending bracket labeled "1. H.". The left hand has a *mf* marking. The system concludes with a double bar line and a repeat sign.

Fourth system of the piano score. It features dynamic markings: *p* (piano), *f* (forte), and *più f* (più forte). The left hand has a *mf* marking. The system concludes with a double bar line and a repeat sign.

Fifth system of the piano score. It includes dynamic markings: *cresc.* (crescendo), *steigernd* (steigernd), *f* (forte), and *ff* (fortissimo). The left hand has a *f* marking. The system concludes with a double bar line and a repeat sign.





caution.tif

