

# 液晶显示模组规格书

## LCD MODULE SPECIFICATION

MODEL NO(模组型号):

JRP5011

|                |               |                |                   |               |                |
|----------------|---------------|----------------|-------------------|---------------|----------------|
| 客户名称:          |               |                |                   |               |                |
| 拟制<br>DESIGNED | 审核<br>CHECKED | 批准<br>APPROVED | 拟制<br>DESIGNED    | 审核<br>CHECKED | 批准<br>APPROVED |
|                |               |                | 吴兴洪<br>2019.11.08 |               |                |





### 目录 Contents

|    |  |       |
|----|--|-------|
| 1  | 1. 产品特征 Product Features-----                            | 4     |
| 2  | 2. 物理规格 Physical Specifications -----                    | 4     |
| 3  | 3. 产品图纸 Product Drawings -----                           | 4     |
| 4  | 4. 接口定义 The Interface Definition-----                    | 6     |
| 5  | 5. 极限参数 Absolute Maximum Ratings -----                   | 7     |
| 6  | 6. 电气参数 Electrical Characteristics -----                 | 7     |
| 7  | 7. 光学参数 Optical Characteristics -----                    | 8     |
| 8  | 8. 电性连接图框 Block Diagram -----                            | 10    |
| 9  | 9. 品质检验标准 LCM Quality Criteria -----                     | 11    |
| 10 | 9.1 外观及功能检验标准 Visual & Function Inspection Standard----- | 11    |
| 11 | 9.1.1 检验条件 Inspection conditions-----                    | 11    |
| 12 | 9.1.2 定义 Definition-----                                 | 11    |
| 13 | 9.1.3 抽样计划 Sampling Plan-----                            | 12    |
| 14 | 9.1.4 目测检验标准 Criteria (Visual)-----                      | 13    |
| 15 | 9.1.5 功能性标准 Criteria ( functional items)-----            | 15    |
| 16 | 9.2 可靠性实验 Reliability Test-----                          | 16    |
| 17 | 9.3 安全说明 Safety instructions-----                        | 17    |
| 18 | 9.4 模组使用注意事项 Handling Precautions-----                   | 17    |
| 19 | 9.5 使用说明 Operation instructions-----                     | 17    |
| 20 | 9.6 存储方法 Storage instructions-----                       | 18    |
| 21 | 9.7 保修期限 Limited Warranty-----                           | 18    |
| 22 | 10.包装方法 Packing method-----                              | 19    |
| 23 | 11.使用方法 Working method-----                              | 19-24 |

### 1. 产品特征 Product Features

| 项目 (Item)                     | 描述(Description)             |
|-------------------------------|-----------------------------|
| (1)产品型号 (Model)               | <b>JRP5011</b>              |
| (2) 显示类型 (Display Type)       | 5.0 inch TFT Normally Black |
| (3) 分辨率 (Resolution)          | 800*RGB*480                 |
| (4) 显示色彩 (color)              | 16.7M                       |
| (5) 视角 (View Angle)           | Full View                   |
| (6) 驱动IC (Driver IC)          | ST5091+ST5625               |
| (7) 接口类型 (Interface Types)    | HDMI                        |
| (8) 连接方式 (Connection mode)    | 显示:HDMI                     |
| (9) 背光模式 (Backlight)          | 6串2并12颗灯                    |
| (10) 产品功耗 (power consumption) | 500mA@5.0V                  |
| (11)产品亮度 (Brightness)         | 500cd/m <sup>2</sup>        |
| (12) 触摸屏 (Touch Panel)        | 无/RTP/CTP                   |

### 2. 物理规格 Physical Specifications

| 项目 (Item)                        | 规格 (Specification) | 单位 (Units) |
|----------------------------------|--------------------|------------|
| (1) 外形尺寸(Outline Dimension)      | 120.7*75.8         | mm         |
| (2) 显示区尺寸(Active Area Dimension) | 108*64.08          | mm         |
| (3) 解析度(Resolution Dimension)    | 800*3RGB*480       | /          |
| (4) 像素点尺寸(Pixel Pitch Dimension) | 45*135             | um         |
| (5) 结构类型(Structure Type)         | COG+FPC+BL (note)  | /          |

Note: COG: Chip On Glass (LCD+IC); BL: Backlight; TP: Touch Panel

### 3. 产品图纸 Product Drawings

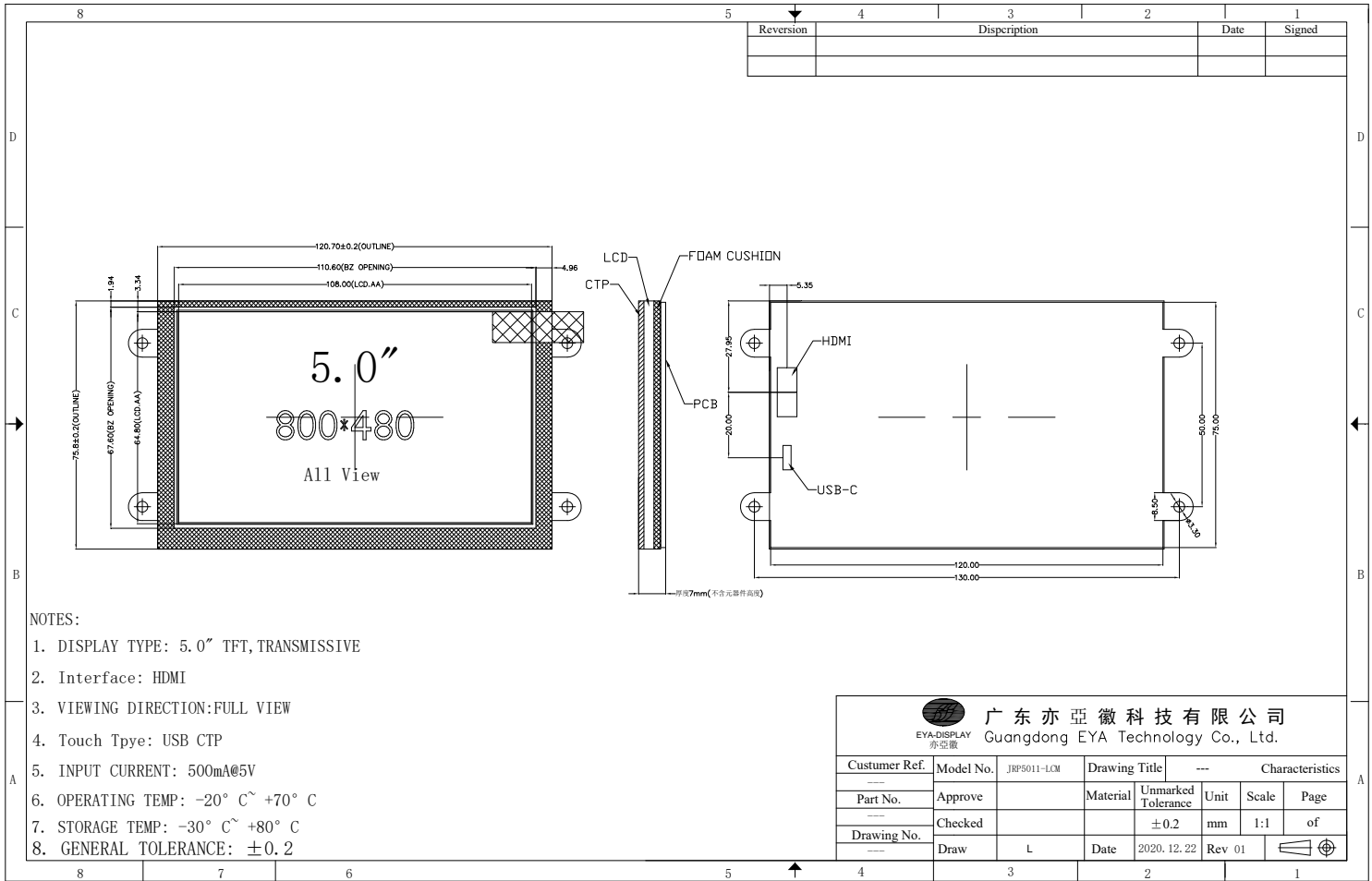

### 4. 接口定义 The Interface Definition

#### HDMI

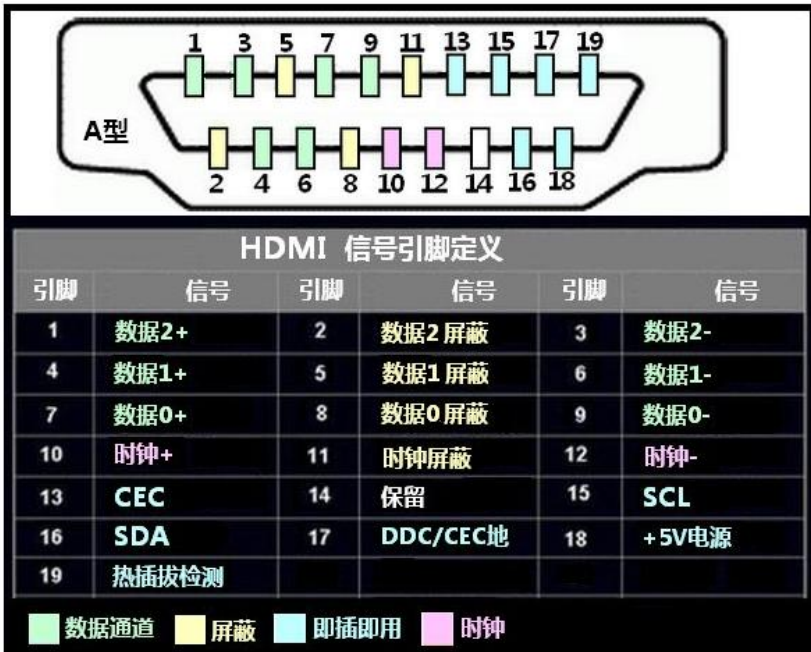

### USB for Touch Panel (USB 触摸接口)

### 5. 极限参数 Absolute Maximum Ratings

| 参数(Parameter)                    | 符号(Symbol) | 最小值(Min) | 最大值(Max)     | 单位(Unit) |
|----------------------------------|------------|----------|--------------|----------|
| 逻辑电压(Supply voltage for logic)   | $V_{CC}$   | -0.3     | 5.0          | V        |
| 输入逻辑电压(Input voltage for logic)  | $V_{IN}$   | -0.5     | $V_{CC}+0.3$ | V        |
| LED 电流 (Supply current(One LED)) | $I_{LED}$  | --       | --           | mA       |
| 工作温度(Operating temperature)      | $T_{OP}$   | -30      | +70          | °C       |
| 存储温度(Storage temperature)        | $T_{ST}$   | -40      | +80          | °C       |

### 6. 电气参数 Electrical Characteristics

| 项目<br>Item                      | 符号<br>Symbol | 最小值<br>Min   | 典型值<br>Typ | 最大值<br>Max   | 单位<br>Unit | 应用终端<br>Applicable<br>terminal |
|---------------------------------|--------------|--------------|------------|--------------|------------|--------------------------------|
| 逻辑电压(Supply voltage for logic)  | $V_{CC}$     | 4.5          | 5.0        | 5.5          | V          | $V_{DD}$                       |
|                                 | IOVCC        | --           | --         | --           | V          | I/O Voltage                    |
| 输入电压(Input voltage)             | $V_{IL}$     | -0.3         | -          | $0.2 V_{DD}$ | V          |                                |
|                                 | $V_{IH}$     | $0.8 V_{CC}$ | -          | $V_{CC}$     |            |                                |
| 输入漏电流(Input leakage current)    | $I_{LKG}$    |              |            |              | $\mu A$    |                                |
| LED 正向电压(LED Forward voltage)   | $V_f$        | --           | --         | --           | V          | --                             |
| 输入背光电流(Input backlight current) | $I_{LED}$    | -            | --         | --           | mA         | With One LED                   |

### 7. 光学参数 Optical Characteristics

| 项目<br>ITEM         | 符号<br>SYMBOL | 条件<br>CONDITIONS                      | 规格(SPECIFICATIONS) |            |            | 单位<br>UNIT | 注意<br>NOTE |
|--------------------|--------------|---------------------------------------|--------------------|------------|------------|------------|------------|
|                    |              |                                       | 最小值<br>MIN         | 典型值<br>TYP | 最大值<br>MAX |            |            |
| 亮度 Brightness      | B            | 正常观察<br>角度<br>Viewing<br>normal angle | --                 | 500        | --         | $Cd.cm^2$  |            |
| 对比度 Contrast Ratio | CR           |                                       | 700                | 800        | --         | --         |            |
| 响应时间 ResponTime    | Tr           |                                       | --                 | 30         | 60         | Msec       |            |
|                    | Tf           |                                       | --                 | 30         | 60         |            |            |
| 颜色坐标<br>CIE        | 红色<br>Red    |                                       | XR                 |            | 0.655      |            |            |
|                    |              | YR                                    |                    | 0.332      |            |            |            |

|                       |                |                |                  |       |       |       |      |
|-----------------------|----------------|----------------|------------------|-------|-------|-------|------|
| Color coordinate      | 绿色<br>Green    | X <sub>G</sub> | Center<br>CR>=10 | -0.02 | 0.314 | +0.02 | Deg. |
|                       |                | Y <sub>G</sub> |                  |       | 0.574 |       |      |
|                       | 蓝色<br>Blue     | X <sub>B</sub> |                  |       | 0.137 |       |      |
|                       |                | Y <sub>B</sub> |                  |       | 0.135 |       |      |
|                       | 白色<br>White    | X <sub>w</sub> |                  |       | 0.305 |       |      |
|                       | Y <sub>w</sub> | 0.341          |                  |       |       |       |      |
| 观察角度<br>Viewing Angle | 水平<br>Hor.     | $\theta_{x+}$  | Center<br>CR>=10 | --    | 80    | --    | Deg. |
|                       |                | $\theta_{x-}$  |                  | --    | 80    | --    |      |
|                       | 垂直<br>Ver.     | $\theta_{y+}$  |                  | --    | 80    | --    |      |
|                       |                | $\theta_{y-}$  |                  | --    | 80    | --    |      |
| 均匀性<br>Uniformity     | Un             |                | --               | 80    | --    | %     |      |

### Note 1: 可视角度的定义 Definition of Viewing Angle:

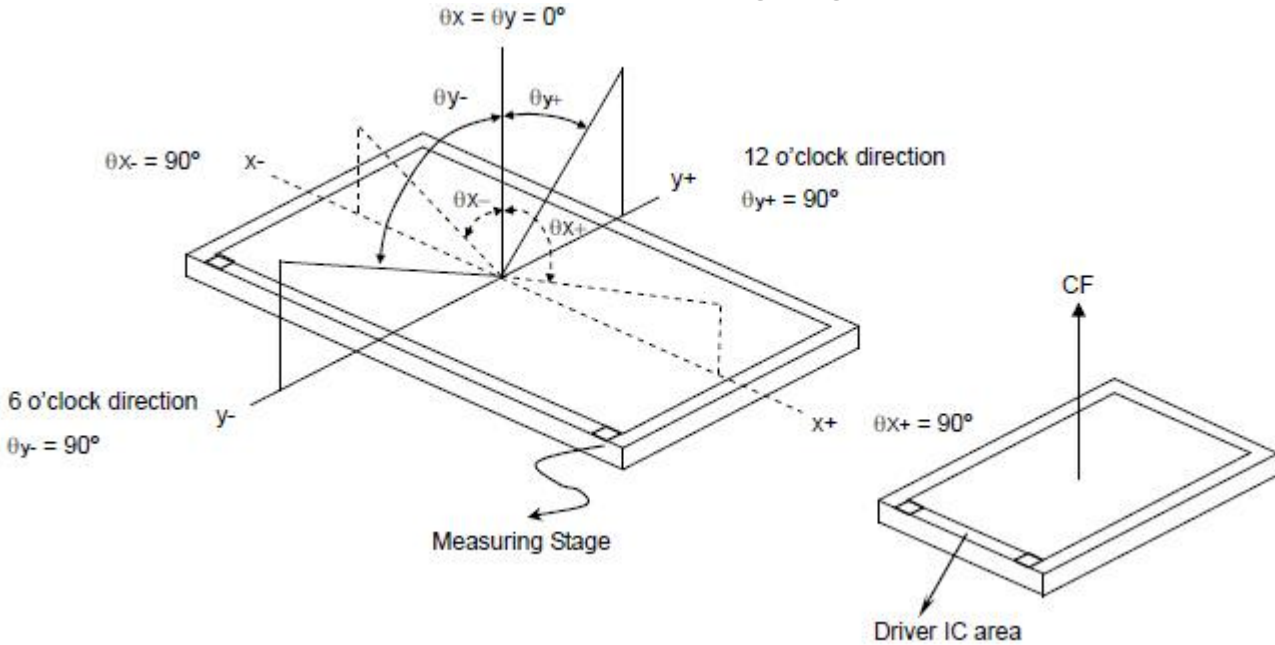

### Note 2: 对比度定义 Definition of contrast ratio CR:

$$CR = \frac{\text{Brightness of non-selected dots (white)}}{\text{Brightness of selected dots (black)}}$$

### Note 3: 响应时间的定义 Definition of response time (T<sub>R</sub>, T<sub>F</sub>)

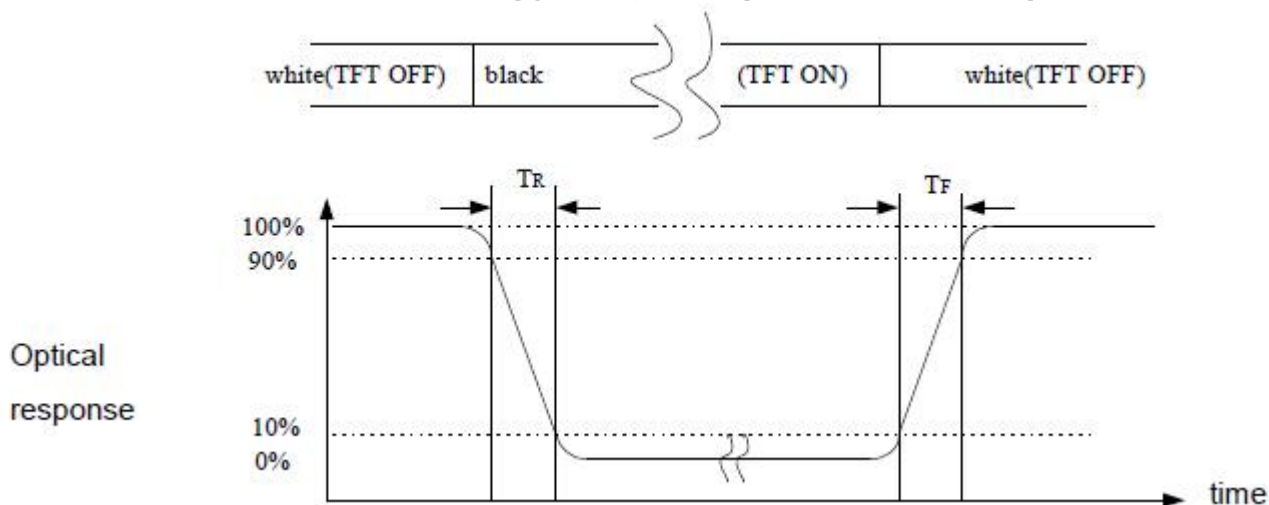

**Note 4: 光学测量装置的定义 Definition of optical measurement setup**

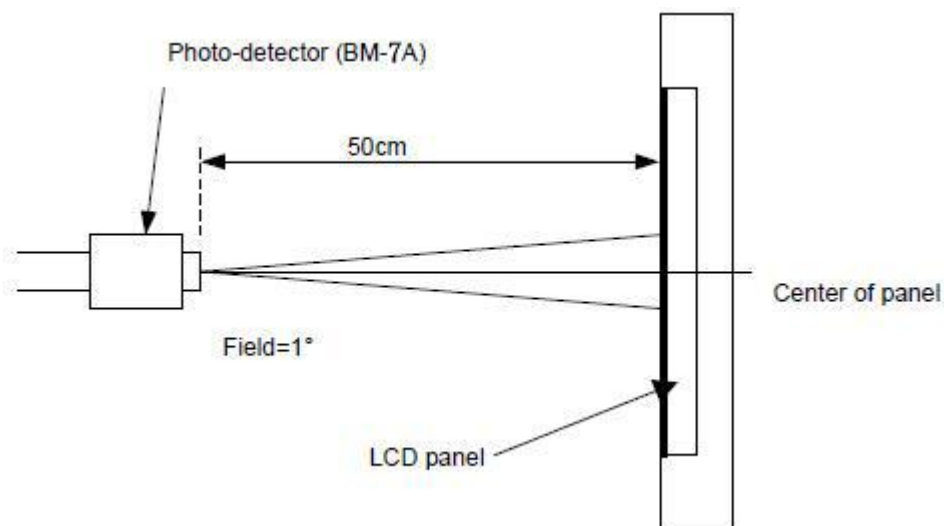

### 8. 电性连接图框 Block Diagram



Driver IC: RTD2660 or Compatible

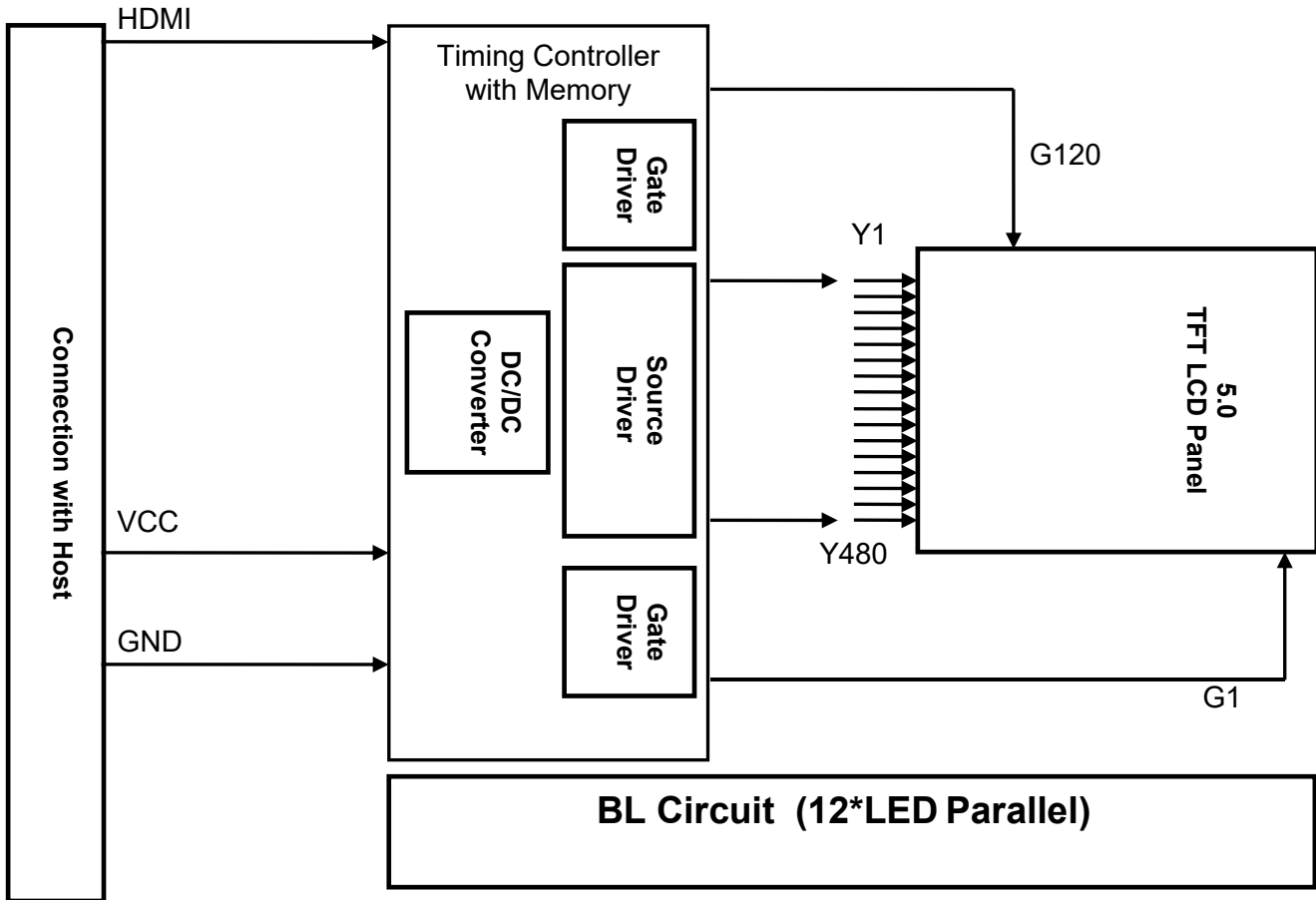

### 9.品质检验标准 LCM Quality Criteria

#### 9.1 外观及功能的检验标准 Visual & Function Inspection Standard

##### 9.1.1 检验条件 Inspection conditions

建议在下列条件下进行检验 Inspection performed under the following conditions is recommended.

|                        |   |
|------------------------|---|
| 温度 Temperature :       | 25±5°C  |
| 湿度 Humidity :          | 65%±10%RH                                     |
| 视角 Viewing Angle :     | 正常的视角 Normal viewing Angle.                   |
| 照明 Illumination:       | 单颗荧光灯 Single fluorescent lamp (300 to 700Lux) |
| 观察距离 Viewing distance: | 30-50 cm                                      |

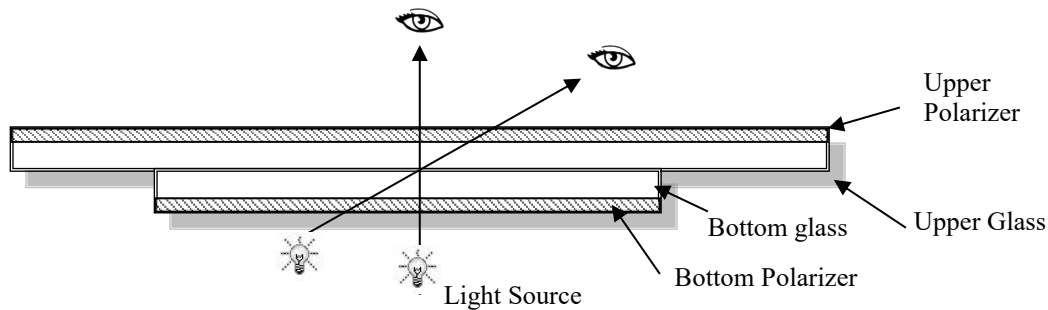

##### 9.1.2 定义 Definition

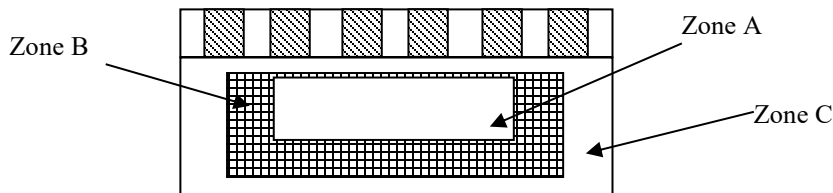

Zone A : 有效显示区域 (显示图像的区域) Effective Viewing Area(Character or Digit can be seen)

Zone B : 观察区 Zone A 除外 Viewing Area except Zone A

Zone C : 外形边框 Outside (Zone A+Zone B) which can not be seen after assembly by customer .)

Note:

一般情况下, 在不影响客户产品装配后的功能或外观, Zone C 的缺损可忽略不计;

As a general rule ,visual defects in Zone C can be ignored when it doesn't effect product function or appearance after assembly by customer.

### 9.1.3 抽样计划 Sampling Plan

根据 GB / T 2828-2003 II类标准正常检验；

According to GB/T 2828-2003 ; , normal inspection, Class II

可接受的质量标准 AQL:

|                   |                   |
|-------------------|-------------------|
| 主要缺陷 Major defect | 次要缺陷 Minor defect |
| 0.65              | 1.5               |

LCD: Liquid Crystal Display , TP: Touch Panel , LCM: Liquid Crystal Module

| 编号<br>No | 需要检查的项目<br>Items to be inspected | 标准<br>Criteria  | 缺陷分类<br>Classification of defects |
|----------|----------------------------------|---|-----------------------------------|
| 1        | 功能缺陷<br>Functional defects       | 1. 无显 No display<br>2. 显示异常 Display abnormally<br>3. 缺画 Missing vertical, horizontal segment<br>4. 短路 Short circuit<br>5. 背光不亮、闪烁或者异常 Back-light no lighting,lickering and abnormal lighting<br>6. 信号交叉串扰 Cross-Talk<br>7. 噪声 Noise<br>8. 色彩对比度不一致 Color contrast | 主要缺陷<br>Major                     |
| 2        | 缺少<br>Missing                    | 缺少的组件 Missing component   |                                   |
| 3        | 外形尺寸<br>Outline dimension        | 整体外形尺寸超出图纸是不允许的范围； Overall outline dimension beyond the drawing is not allowed  |                                   |
| 4        | 色调<br>Color tone                 | 指与样品的色调有差异； Color unevenness, refer to limited sample   | 次要缺陷<br>Minor                     |
| 5        | 焊接外观<br>Soldering appearance     | 良好的焊接，不允许虚焊； Good soldering , Peeling off is not allowed.   |                                   |
| 6        | 玻璃/偏光片<br>LCD/Polarizer          | 黑白点/线，划痕，裂纹等。<br>Black/White spot/line, scratch, crack, etc.  |                                   |

### 9.1.4 目测检验标准 Criteria (Visual)

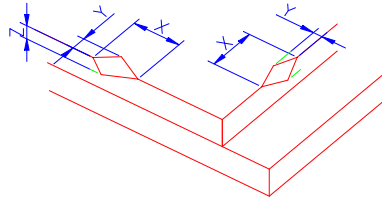
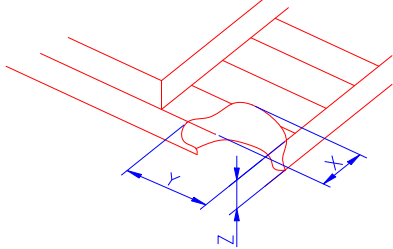
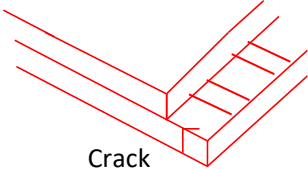
| 编号<br>Number  | 项目<br>Items   | 标准<br>Criteria(mm)  |    |   |        |        |                                |    |
|---|---|---|----|---|--------|--------|--------------------------------|----|
| 1.0<br><br>LCD<br>Crack/Broken<br>裂痕/破裂<br><br>NOTE:<br>X: Length<br>Y: Width<br>Z: Height<br>L: Length of<br>ITO,<br>T: Height of<br>LCD | (1) 玻璃边缘破裂<br>The edge of LCD broken  |  <table border="1" data-bbox="821 763 1366 920"> <thead> <tr> <th>X</th> <th>Y</th> <th>Z</th> </tr> </thead> <tbody> <tr> <td>≤1.5mm</td> <td>&lt;Inner border line of the seal</td> <td>≤T</td> </tr> </tbody> </table> | X  | Y | Z      | ≤1.5mm | <Inner border line of the seal | ≤T |
|   | X   | Y   | Z  |   |        |        |                                |    |
|   | ≤1.5mm  | <Inner border line of the seal  | ≤T |   |        |        |                                |    |
| (2) 玻璃崩角<br>LCD corner broken   |  <table border="1" data-bbox="882 1274 1305 1348"> <thead> <tr> <th>X</th> <th>Y</th> <th>Z</th> </tr> </thead> <tbody> <tr> <td>≤1.5mm</td> <td>≤1.0mm</td> <td>≤T</td> </tr> </tbody> </table> | X   | Y  | Z | ≤1.5mm | ≤1.0mm | ≤T                             |    |
| X   | Y   | Z   |    |   |        |        |                                |    |
| ≤1.5mm  | ≤1.0mm  | ≤T  |    |   |        |        |                                |    |
| (3) 玻璃裂纹<br>LCD crack   |  <p>Crack<br/>不允许; Not allowed</p>  |   |    |   |        |        |                                |    |

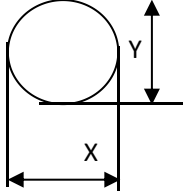
| 编号<br>Number            | 项目<br>Items   | 标准<br>Criteria (mm)   |                   |                     |                     |                  |           |           |                      |                  |           |            |   |                         |   |  |  |                        |   |  |  |              |   |  |  |                   |                     |  |  |   |   |   |                 |           |  |  |                       |   |  |  |                       |   |  |  |              |   |  |  |
|-------------------------|---|---|-------------------|---------------------|---------------------|------------------|-----------|-----------|----------------------|------------------|-----------|------------|---|-------------------------|---|--|--|------------------------|---|--|--|--------------|---|--|--|-------------------|---------------------|--|--|---|---|---|-----------------|-----------|--|--|-----------------------|---|--|--|-----------------------|---|--|--|--------------|---|--|--|
| 2.0                     | 点缺陷<br>Spot defect<br><br><br><br>$\Phi=(X+Y)/2$ | ① 光点 (LCD/TP/偏光片黑/白点, 轻点, 针孔, 凹陷, 彩点)<br>light dot (LCD/TP/Polarizer black/white spot, light dot, pinhole, dent, stain)<br><table border="1" data-bbox="443 533 1228 896"> <thead> <tr> <th rowspan="2">Zone<br/>Size (mm)</th> <th colspan="3">允许数量 Acceptable Qty</th> </tr> <tr> <th>A</th> <th>B</th> <th>C</th> </tr> </thead> <tbody> <tr> <td><math>\Phi \leq 0.10</math></td> <td colspan="3">忽略 Ignore</td> </tr> <tr> <td><math>0.10 &lt; \Phi \leq 0.15</math></td> <td colspan="3">2</td> </tr> <tr> <td><math>0.15 &lt; \Phi \leq 0.2</math></td> <td colspan="3">1</td> </tr> <tr> <td><math>0.2 &lt; \Phi</math></td> <td colspan="3">0</td> </tr> </tbody> </table><br>② 暗点 (LCD/TP/偏光片漏光昏暗的点、黑点) Dim spot (LCD/TP/Polarizer dim dot, light leakage, dark spot)<br><table border="1" data-bbox="443 1003 1228 1366"> <thead> <tr> <th rowspan="2">Zone<br/>Size (mm)</th> <th colspan="3">允许数量 Acceptable Qty</th> </tr> <tr> <th>A</th> <th>B</th> <th>C</th> </tr> </thead> <tbody> <tr> <td><math>\Phi \leq 0.1</math></td> <td colspan="3">忽略 Ignore</td> </tr> <tr> <td><math>0.1 &lt; \Phi \leq 0.2</math></td> <td colspan="3">2</td> </tr> <tr> <td><math>0.2 &lt; \Phi \leq 0.3</math></td> <td colspan="3">1</td> </tr> <tr> <td><math>\Phi &gt; 0.3</math></td> <td colspan="3">0</td> </tr> </tbody> </table> | Zone<br>Size (mm) | 允许数量 Acceptable Qty |                     |                  | A         | B         | C                    | $\Phi \leq 0.10$ | 忽略 Ignore |            |   | $0.10 < \Phi \leq 0.15$ | 2 |  |  | $0.15 < \Phi \leq 0.2$ | 1 |  |  | $0.2 < \Phi$ | 0 |  |  | Zone<br>Size (mm) | 允许数量 Acceptable Qty |  |  | A | B | C | $\Phi \leq 0.1$ | 忽略 Ignore |  |  | $0.1 < \Phi \leq 0.2$ | 2 |  |  | $0.2 < \Phi \leq 0.3$ | 1 |  |  | $\Phi > 0.3$ | 0 |  |  |
| Zone<br>Size (mm)       | 允许数量 Acceptable Qty   |   |                   |                     |                     |                  |           |           |                      |                  |           |            |   |                         |   |  |  |                        |   |  |  |              |   |  |  |                   |                     |  |  |   |   |   |                 |           |  |  |                       |   |  |  |                       |   |  |  |              |   |  |  |
|                         | A   | B   | C                 |                     |                     |                  |           |           |                      |                  |           |            |   |                         |   |  |  |                        |   |  |  |              |   |  |  |                   |                     |  |  |   |   |   |                 |           |  |  |                       |   |  |  |                       |   |  |  |              |   |  |  |
| $\Phi \leq 0.10$        | 忽略 Ignore   |   |                   |                     |                     |                  |           |           |                      |                  |           |            |   |                         |   |  |  |                        |   |  |  |              |   |  |  |                   |                     |  |  |   |   |   |                 |           |  |  |                       |   |  |  |                       |   |  |  |              |   |  |  |
| $0.10 < \Phi \leq 0.15$ | 2   |   |                   |                     |                     |                  |           |           |                      |                  |           |            |   |                         |   |  |  |                        |   |  |  |              |   |  |  |                   |                     |  |  |   |   |   |                 |           |  |  |                       |   |  |  |                       |   |  |  |              |   |  |  |
| $0.15 < \Phi \leq 0.2$  | 1   |   |                   |                     |                     |                  |           |           |                      |                  |           |            |   |                         |   |  |  |                        |   |  |  |              |   |  |  |                   |                     |  |  |   |   |   |                 |           |  |  |                       |   |  |  |                       |   |  |  |              |   |  |  |
| $0.2 < \Phi$            | 0   |   |                   |                     |                     |                  |           |           |                      |                  |           |            |   |                         |   |  |  |                        |   |  |  |              |   |  |  |                   |                     |  |  |   |   |   |                 |           |  |  |                       |   |  |  |                       |   |  |  |              |   |  |  |
| Zone<br>Size (mm)       | 允许数量 Acceptable Qty   |   |                   |                     |                     |                  |           |           |                      |                  |           |            |   |                         |   |  |  |                        |   |  |  |              |   |  |  |                   |                     |  |  |   |   |   |                 |           |  |  |                       |   |  |  |                       |   |  |  |              |   |  |  |
|                         | A   | B   | C                 |                     |                     |                  |           |           |                      |                  |           |            |   |                         |   |  |  |                        |   |  |  |              |   |  |  |                   |                     |  |  |   |   |   |                 |           |  |  |                       |   |  |  |                       |   |  |  |              |   |  |  |
| $\Phi \leq 0.1$         | 忽略 Ignore   |   |                   |                     |                     |                  |           |           |                      |                  |           |            |   |                         |   |  |  |                        |   |  |  |              |   |  |  |                   |                     |  |  |   |   |   |                 |           |  |  |                       |   |  |  |                       |   |  |  |              |   |  |  |
| $0.1 < \Phi \leq 0.2$   | 2   |   |                   |                     |                     |                  |           |           |                      |                  |           |            |   |                         |   |  |  |                        |   |  |  |              |   |  |  |                   |                     |  |  |   |   |   |                 |           |  |  |                       |   |  |  |                       |   |  |  |              |   |  |  |
| $0.2 < \Phi \leq 0.3$   | 1   |   |                   |                     |                     |                  |           |           |                      |                  |           |            |   |                         |   |  |  |                        |   |  |  |              |   |  |  |                   |                     |  |  |   |   |   |                 |           |  |  |                       |   |  |  |                       |   |  |  |              |   |  |  |
| $\Phi > 0.3$            | 0   |   |                   |                     |                     |                  |           |           |                      |                  |           |            |   |                         |   |  |  |                        |   |  |  |              |   |  |  |                   |                     |  |  |   |   |   |                 |           |  |  |                       |   |  |  |                       |   |  |  |              |   |  |  |
|                         | 线缺陷<br>LCD/偏光片黑/白线、划痕、彩色<br>Line defect (LCD/Polarizer black/white line, scratch, stain)  | <table border="1" data-bbox="443 1433 1252 1736"> <thead> <tr> <th>Width(mm)</th> <th>Length(mm)</th> <th>允许数量 Acceptable Qty</th> </tr> </thead> <tbody> <tr> <td><math>\Phi \leq 0.03</math></td> <td>忽略 Ignore</td> <td>忽略 Ignore</td> </tr> <tr> <td><math>0.03 &lt; W \leq 0.05</math></td> <td><math>L \leq 2.0</math></td> <td>1</td> </tr> <tr> <td><math>0.05 &lt; W</math></td> <td colspan="2">0</td> </tr> </tbody> </table>  | Width(mm)         | Length(mm)          | 允许数量 Acceptable Qty | $\Phi \leq 0.03$ | 忽略 Ignore | 忽略 Ignore | $0.03 < W \leq 0.05$ | $L \leq 2.0$     | 1         | $0.05 < W$ | 0 |                         |   |  |  |                        |   |  |  |              |   |  |  |                   |                     |  |  |   |   |   |                 |           |  |  |                       |   |  |  |                       |   |  |  |              |   |  |  |
| Width(mm)               | Length(mm)  | 允许数量 Acceptable Qty   |                   |                     |                     |                  |           |           |                      |                  |           |            |   |                         |   |  |  |                        |   |  |  |              |   |  |  |                   |                     |  |  |   |   |   |                 |           |  |  |                       |   |  |  |                       |   |  |  |              |   |  |  |
| $\Phi \leq 0.03$        | 忽略 Ignore   | 忽略 Ignore   |                   |                     |                     |                  |           |           |                      |                  |           |            |   |                         |   |  |  |                        |   |  |  |              |   |  |  |                   |                     |  |  |   |   |   |                 |           |  |  |                       |   |  |  |                       |   |  |  |              |   |  |  |
| $0.03 < W \leq 0.05$    | $L \leq 2.0$  | 1   |                   |                     |                     |                  |           |           |                      |                  |           |            |   |                         |   |  |  |                        |   |  |  |              |   |  |  |                   |                     |  |  |   |   |   |                 |           |  |  |                       |   |  |  |                       |   |  |  |              |   |  |  |
| $0.05 < W$              | 0   |   |                   |                     |                     |                  |           |           |                      |                  |           |            |   |                         |   |  |  |                        |   |  |  |              |   |  |  |                   |                     |  |  |   |   |   |                 |           |  |  |                       |   |  |  |                       |   |  |  |              |   |  |  |

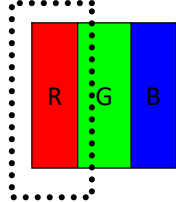
| 3.0                                     | 偏光片划伤<br>Polarizer<br>scratch | <table border="1"> <tr> <th>Width(mm)</th> <th>Length(mm)</th> <th>允许数量 Acceptable Qty</th> </tr> <tr> <td><math>W \leq 0.03</math></td> <td>忽略 Ignore</td> <td>忽略 Ignore</td> </tr> <tr> <td><math>0.03 &lt; W \leq 0.05</math></td> <td><math>L \leq 2</math></td> <td>2</td> </tr> <tr> <td><math>0.05 &lt; W \leq 0.10</math></td> <td><math>L \leq 1</math></td> <td>1</td> </tr> <tr> <td colspan="2"><math>W &gt; 0.10\text{mm}</math> or <math>L &gt; 2\text{mm}</math></td> <td>0</td> </tr> </table>   | Width(mm)           | Length(mm)          | 允许数量 Acceptable Qty       | $W \leq 0.03$    | 忽略 Ignore                | 忽略 Ignore | $0.03 < W \leq 0.05$         | $L \leq 2$ | 2              | $0.05 < W \leq 0.10$ | $L \leq 1$ | 1                         | $W > 0.10\text{mm}$ or $L > 2\text{mm}$ |  | 0 |
|---|-------------------------------|--|---------------------|---------------------|---------------------------|------------------|--------------------------|-----------|------------------------------|------------|----------------|----------------------|------------|---------------------------|---|--|---|
|   | Width(mm)                     | Length(mm)   | 允许数量 Acceptable Qty |                     |                           |                  |                          |           |                              |            |                |                      |            |                           |   |  |   |
| $W \leq 0.03$                           | 忽略 Ignore                     | 忽略 Ignore  |                     |                     |                           |                  |                          |           |                              |            |                |                      |            |                           |   |  |   |
| $0.03 < W \leq 0.05$                    | $L \leq 2$                    | 2  |                     |                     |                           |                  |                          |           |                              |            |                |                      |            |                           |   |  |   |
| $0.05 < W \leq 0.10$                    | $L \leq 1$                    | 1  |                     |                     |                           |                  |                          |           |                              |            |                |                      |            |                           |   |  |   |
| $W > 0.10\text{mm}$ or $L > 2\text{mm}$ |                               | 0  |                     |                     |                           |                  |                          |           |                              |            |                |                      |            |                           |   |  |   |
| 3.0                                     | 偏光片气泡<br>Polarizer<br>Bubble  | <table border="1"> <tr> <th>Zone<br/>Size (mm)</th> <th>允许数量 Acceptable Qty</th> </tr> <tr> <td><math>\Phi \leq 0.1</math></td> <td>忽略 Ignore</td> </tr> <tr> <td><math>0.1 &lt; \Phi \leq 0.2</math></td> <td>2</td> </tr> <tr> <td><math>0.2 &lt; \Phi \leq 0.3</math></td> <td>1</td> </tr> <tr> <td><math>0.3 &lt; \Phi</math></td> <td>0</td> </tr> </table>  | Zone<br>Size (mm)   | 允许数量 Acceptable Qty | $\Phi \leq 0.1$           | 忽略 Ignore        | $0.1 < \Phi \leq 0.2$    | 2         | $0.2 < \Phi \leq 0.3$        | 1          | $0.3 < \Phi$   | 0                    |            |                           |   |  |   |
| Zone<br>Size (mm)                       | 允许数量 Acceptable Qty           |  |                     |                     |                           |                  |                          |           |                              |            |                |                      |            |                           |   |  |   |
| $\Phi \leq 0.1$                         | 忽略 Ignore                     |  |                     |                     |                           |                  |                          |           |                              |            |                |                      |            |                           |   |  |   |
| $0.1 < \Phi \leq 0.2$                   | 2                             |  |                     |                     |                           |                  |                          |           |                              |            |                |                      |            |                           |   |  |   |
| $0.2 < \Phi \leq 0.3$                   | 1                             |  |                     |                     |                           |                  |                          |           |                              |            |                |                      |            |                           |   |  |   |
| $0.3 < \Phi$                            | 0                             |  |                     |                     |                           |                  |                          |           |                              |            |                |                      |            |                           |   |  |   |
| 4.0                                     | 贴片电子元器件<br>SMT                | 根据<电子组件接受 IPC-A-610C 2 级标准>。组件丢失或功能缺陷是主要的缺陷，其他是次要缺陷。According to the <Acceptability of electronic assemblies> IPC-A-610C class 2 standard. Component missing or function defect are Major defect, the others are Minor defect.   |                     |                     |                           |                  |                          |           |                              |            |                |                      |            |                           |   |  |   |
| 5.0                                     | TFT                           | <table border="1"> <thead> <tr> <th>区分<br/>distinguish</th> <th>类型<br/>type</th> <th>允许数量<br/>Acceptable<br/>Qty</th> </tr> </thead> <tbody> <tr> <td rowspan="2">亮点<br/>Bright dot</td> <td>任何颜色<br/>Any color window</td> <td>0</td> </tr> <tr> <td>相邻的亮点<br/>Adjacent Bright dot</td> <td>0</td> </tr> <tr> <td rowspan="2">黑点<br/>Dark dot</td> <td>黑点<br/>Dark dot</td> <td>1</td> </tr> <tr> <td>相邻黑点<br/>Adjacent Dark dot</td> <td>0</td> </tr> </tbody> </table> <p>Note: the red (R), green (G), blue (B) 3 points constitute a pixel</p>  <p>Dot</p> | 区分<br>distinguish   | 类型<br>type          | 允许数量<br>Acceptable<br>Qty | 亮点<br>Bright dot | 任何颜色<br>Any color window | 0         | 相邻的亮点<br>Adjacent Bright dot | 0          | 黑点<br>Dark dot | 黑点<br>Dark dot       | 1          | 相邻黑点<br>Adjacent Dark dot | 0                                       |  |   |
| 区分<br>distinguish                       | 类型<br>type                    | 允许数量<br>Acceptable<br>Qty  |                     |                     |                           |                  |                          |           |                              |            |                |                      |            |                           |   |  |   |
| 亮点<br>Bright dot                        | 任何颜色<br>Any color window      | 0  |                     |                     |                           |                  |                          |           |                              |            |                |                      |            |                           |   |  |   |
|   | 相邻的亮点<br>Adjacent Bright dot  | 0  |                     |                     |                           |                  |                          |           |                              |            |                |                      |            |                           |   |  |   |
| 黑点<br>Dark dot                          | 黑点<br>Dark dot                | 1  |                     |                     |                           |                  |                          |           |                              |            |                |                      |            |                           |   |  |   |
|   | 相邻黑点<br>Adjacent Dark dot     | 0  |                     |                     |                           |                  |                          |           |                              |            |                |                      |            |                           |   |  |   |

### 9.1.5 功能性标准 Criteria ( functional items)

| 项目 Items                                 | 标准 Criteria      |
|--|------------------|
| 无显 No display                            | 不允许; Not allowed |
| 显示异常 Display abnormally                  | 不允许; Not allowed |
| 缺画 Missing vertical, horizontal          | 不允许; Not allowed |
| 组件分离 Segment                             | 不允许; Not allowed |
| 短路 Short circuit                         | 不允许; Not allowed |
| 背光不亮 Back-light no lighting,             | 不允许; Not allowed |
| 背光闪烁或异常 Flickering and abnormal lighting | 不允许; Not allowed |
| 信号交叉串扰 Cross-Talk                        | 不允许; Not allowed |

|                                |  |
|--------------------------------|--|
| 噪声 Noise                       | 不允许; Not allowed   |
| 色彩对比度不一致 Color contrast        | 不允许; Not allowed   |
| 玻璃表面污垢 The LCD surface dirt    | 如果客户不能自行擦除干净, 也是不可接受的;<br>If you cannot use smudgy surface air clean and clear, coco is not acceptable |
| 缺少元器件 Components off           | 不允许; Not allowed   |
| FPC&PCB 不良 FPC&PCB undesirable | 不允许; Not allowed   |
| 铁框支架变形 Iron frame deformation  | 不允许; Not allowed   |

## 9.2 可靠性实验 Reliability Test

| 项目<br>ITEM                    | 条件<br>Condition  | 样品数量<br>Sample size | 标准<br>Criterion  |
|-------------------------------|--|---------------------|--|
| 高温储存<br>High Temp. Storage    | +80°C ± 2°C, 120 小时 hrs  | 5pcs                | 检查后2 ~ 4小时存储在室温下, 该样品应无缺陷:<br>1. 液晶显示器无气泡;<br>2. 液晶无漏液;<br>3. 显示正常;<br>4. 不缺少部件;<br>5. 表面应无损伤;<br>6. 线性度测试仪检测对比度必须不超过10%。<br>7. 线性度测试仪检测电源不超过10%。<br><br>Inspection after 2~4hours storage at room temperature, the sample shall be free from defects:<br>1.Air bubble in the LCD;<br>2.Sealleak;<br>3.Non-display;<br>4.Missing segments;<br>5. The surface shall be free from damage.<br>6. Contrast must be no more than 10% by the linearity tester. |
| 低温储存<br>Low Temp. Storage     | -30°C ± 2°C, 120 小时 hrs  | 5pcs                |  |
| 高温运行<br>High Temp. Operation  | +70°C ± 2°C, 72 小时 hrs   | 5pcs                |  |
| 低温运行<br>Low Temp. Operation   | -20°C ± 2°C, 72 小时 hrs   | 5pcs                |  |
| 湿度运行<br>Humidity operation    | 40°C, 90%RH, 72 小时 hrs   | 5pcs                |  |
| 湿度储存<br>Humidity storage      | 70°C, 90%RH, 72 小时 hrs   | 5pcs                |  |
| 温湿度循环<br>Temp humidity cycles | 25°C → Calefaction/3hrs →<br>60°C/9hrs → Descend temp/3hrs 25°C/9hrs<br>→ 90%RH<br><br>Total:10 cycles | 5pcs                |  |
| 冷热冲击循环<br>Thermal shock       | -30°C/30min → 80°C/30mins<br><br>Total:10 cycles   | 5pcs                |  |
| 震动<br>Vibration               | Amplitude between 10 and 150Hz:3G(100m/s <sup>2</sup> ) /2hrs for each direction(X,Y,Z)                | 1Carton-box         | 经过测试, 没有任何有缺陷的表现或电气性能。After testing, there are no any defective appearances or electrical properties.  |
| 跌落测试<br>Drop test             | 1.5m, 10times  | 1Carton-box         |  |

|             |  |      |   |
|-------------|--|------|---|
| 静电测试<br>ESD | 1.Contact discharge method $\pm 6KV, 150pF/330\Omega$<br>10times | 5pcs | 1. 经过测试，没有任何有缺陷的表现或电气性能。<br>2. 在可以接受时，所有有缺陷的现象在ESD复位后消失。<br>1. After testing, there are no any defective appearances or electrical properties.<br>2. It can be acceptable when all defective ESD disappears in the RESET. |
|             | 2.Air discharge method $\pm 8KV, 150pF/330\Omega$<br>10times     | 5pcs |   |

### 9.3 安全说明 Safety instructions

- 9.3.1 如果液晶面板断裂，小心不要让任何液晶物质进入到口中；  
If the LCD panel breaks, be careful not to get any liquid crystal substance in your mouth.
- 9.3.2 如果液晶物质触及你的皮肤或衣物，请立即用肥皂和水清洗干净；  
If the liquid crystal substance touches your skin or clothes, please wash it off immediately by using soap and water.

### 9.4 模组使用注意事项 Handling Precautions

- 9.4.1 客户在做结构设计时，请保证机壳开窗尺寸比触摸屏 V.A 单边少 0.3mm，泡棉开窗尺寸比触摸屏 V.A 单边大 0.2mm；  
Customers do structural design, please ensure the cabinet window size smaller than the touch screen VA unilateral 0.3mm. Foam window size larger than 0.2mm unilateral touchscreen V.A
- 9.4.2 防止静电损坏集成电路  
Avoid static electricity damaging the LSI.
- 9.4.3 不要从模块中拆下玻璃面板或铁框支架  
Do not remove the panel or frame from the module .
- 9.4.4 显示屏的偏光片是很脆弱的。所以请注意要非常小心，避免损坏；  
The polarizing plate of the display is very fragile . So, please handle it very carefully.
- 9.4.5 不要用干布擦拭偏光片，因为很容易刮伤到它的表面；  
Do not wipe the polarizing plate with a dry cloth, as it may easily scratch the surface of the plate.
- 9.4.6 显示颜色和背景色调有可能随着储存温度范围的变化而发生改变；  
The color tone of display and background of LCM has the possibility to be changed in the storage temperature range.
- 9.4.7 注意工作使用环境，产品可能会被静电所损坏；  
Pay attention to the working environment, as the element may be destroyed by static electricity.  
--确保使用作业人员身体可靠的接地；  
Be sure to ground human body and electric appliance during work.  
--避免在干燥的环境中作业，减少静电的损害；  
Avoid working in a dry environment to minimize the generations of static electricity.  
--在作业过程中，快速剥离保护膜时可能会引起静电；  
Static electricity may be generated when the protective film is fast peeled off.
- 9.4.8 当焊接 LCM 端子时，确保使用交流电源的烙铁不漏电；  
When soldering the terminal of LCM, make certain the AC power source of soldering iron does not leak.
- 9.4.9 潮湿的环境可能引起玻璃 ITO 的腐蚀，在使用中，请确保湿度在 50%以下。  
Humid environment may cause a bad ITO glass corrosion, in use, make sure the humidity is below 50%.
- 9.4.10 如果液晶显示模组的表面被污染，可以使用柔软的无尘布在表面上轻轻的擦拭。如果是严重的污染，可以用无尘布蘸上酒精轻轻擦拭。特别是不可使用可能损坏偏光片的溶剂（例如：水/酮） If the display



surface becomes contaminated ,breathe on the surface and gently wipe it with a soft-dry- clean cloth .If it is heavily contaminated ,moisten cloth with the following solvent(ex:Ethyl alcohol).Solvents other than those above-mentioned may damage the polarizer(Especially ,do not use them .ex: Warter / Ketone)

### 9.5 使用说明 Operation instructions

9.5.1 推荐使用 在规定的电压范围内驱动液晶显示面板，尝试调整工作电压为达到最佳的对比度，在不同的温度液晶显示面板的颜色和对比度会有所不同；

It is recommended to drive the LCD within the specified voltage limits, try to adjust the operating voltage for the optimal contrast, the color and contrast of LCD panel will varies at different temperature.

9.5.2 在较低的工作温度范围液晶的响应时间会大大延迟。但这并不意味着液晶会失灵，使它返回到指定的温度范围他将会恢复到正常的状态；

Response time is greatly delayed at low operating temperature range. However, this does not mean the LCD will be out of the order, It will recover when it returns to the specified temperature range.

9.5.3 液晶显示模块在工作时如果显示区遭到硬物压力，液晶显示模块将会变得显示异常；

If the display area is pushed hard during operation, the display will become abnormal.

9.5.4 不在特定条件下的环境中使用 LCD，可能会导致液晶的损伤和寿命的缩短；

Do not operate the LCD at the environments over the specified conditions, this may cause damage on the LCD and shorten the lifetime.

### 9.6 存储方法 Storage instructions:

9.6.1 将液晶显示模组存储在密封的聚乙烯袋中；

Store LCDs in a sealed polyethylene bag.

9.6.2 将液晶显示模组放置在黑暗的地方，不要暴露在阳光或者日光灯下，保持 0°C 到 35°C 之间的温度； Store LCDs in a dark place, Do not expose to sunlight or fluorescent light. Keep the temperature between 0°C and 35°C.

9.6.3 避免接触任何其他震动的物体，建议将他们存储在固定的容器中，便于搬运；

Avoid the polarizer touch any other object, ( It is recommended to store them in the container in which they were shipped.)

### 9.7 保修期限 Limited Warranty

9.7.1 按照检查验收标准(或商定好的要求)，发现产品有缺陷的，从产品喷墨打印的生产日期起，我司提供 12 个月的产品维修保障服务；

will replace or repair any of its LCD modules, which are found to be defective, when inspected in accordance with LCM acceptance standards ( copies available upon request ) for a period of 12 months from ink- print date on product

9.7.2 任何有缺陷的产品必须从收到货后 60 天内退回，以送货单据做为计算日期的依据；品质责任区分依据 (9.1,9.2)；

Any defects must be returned to within 60 days since ship-out. Confirmation of such date shall be based on freight documents. The warranty liability of was am limited to repair and/or replacement on defects above (7.1,7.2)

9.7.3 如果是因为保护预防措施不当，造成下述的问题，将不提供保修：

No warranty can be granted if the precautions stated above have been disregarded. The typical samples are as below:

--液晶显示屏破裂/裂纹 LCD glass crack/break

-- PCB 插座损坏或修改 PCB outlet is damaged or modified.

--损坏的 PCB 导体 PCB conductors damaged.

--电路经过人为的研磨、雕刻或绘画漆修饰 Circuit modified with by grinding, engraving or painting varnish.

-- FPC 有断裂纹 FPC crack

9.7.4 必须将有缺陷的模块标识清楚问题现象，必须将安装的任何连接物体彻底分离清除，而不损坏 PCB 插座、电路和端子，液晶显示屏必须用专用的包装盒包装运输；

Modules must be returned with sufficient description of the failures of defects. Any connectors or cable installed by the customer must be removed completely without damaging the PCB outlet, conductors and terminals.

Modules must be packed with the container in which they were shipped.

## 10. 包装方法 Packing method

包装示意图 Package picture:

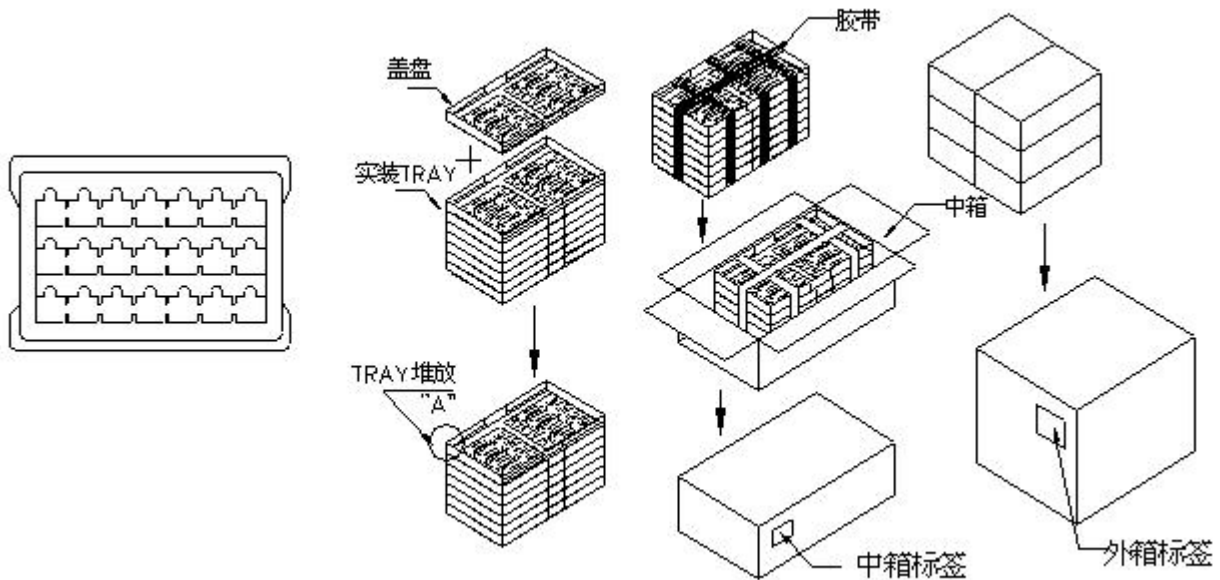

详细信息请咨询我们的技术部门

FAE罗工: 19154914866

Please consult our technical department for detail information.