

XcalableMP
<ex-scalable-em-p>
Language Specification

Version 1.1

XcalableMP Specification Working Group

November, 2012

Copyright ©2008-2012 XcalableMP Specification Working Group. Permission to copy without fee all or part of this material is granted, provided the XcalableMP Specification Working Group copyright notice and the title of this document appear. Notice is given that copying is by permission of XcalableMP Specification Working Group.

Contents

1	Introduction	1
1.1	Features of XcalableMP	1
1.2	Scope	2
1.3	Organization of this Document	2
1.4	Changes from Version 1.0	2
2	Overview of the XcalableMP Model and Language	3
2.1	Hardware Model	3
2.2	Execution Model	3
2.3	Data Model	4
2.4	Global-view Programming Model	4
2.5	Local-view Programming Model	5
2.6	Interactions between the Global View and the Local View	6
2.7	Base Languages	6
2.8	Glossary	7
2.8.1	Language Terminology	7
2.8.2	Node Terminology	8
2.8.3	Data Terminology	10
2.8.4	Work Terminology	10
2.8.5	Communication and Synchronization Terminology	10
2.8.6	Local-view Terminology	11
3	Directives	13
3.1	Directive Format	13
3.1.1	General Rule	13
3.1.2	Combined Directive	15
3.2	nodes Directive	15
3.2.1	Node Reference	17
3.3	Template and Data Mapping Directives	18
3.3.1	template Directive	18
3.3.2	Template Reference	19
3.3.3	distribute Directive	20
3.3.4	align Directive	22
3.3.5	shadow Directive	25
3.3.6	template_fix Construct	26
3.4	Work Mapping Construct	27
3.4.1	task Construct	27
3.4.2	tasks Construct	29
3.4.3	loop Construct	31
3.4.4	array Construct	38

3.5	Global-view Communication and Synchronization Constructs	39
3.5.1	<code>reflect</code> Construct	39
3.5.2	<code>gmove</code> Construct	41
3.5.3	<code>barrier</code> Construct	43
3.5.4	<code>reduction</code> Construct	43
3.5.5	<code>bcast</code> Construct	46
3.5.6	<code>wait_async</code> Construct	47
3.5.7	<code>async</code> Clause	48
4	Support for the Local-view Programming	49
4.1	Rules Determining Image Index	49
4.1.1	Primary Image Index	49
4.1.2	Image Index Determined by a <code>task</code> Directive	50
4.1.3	Current Image Index	50
4.1.4	Image Index Determined by a Non-primary Node Array	50
4.1.5	Image Index Determined by an Equivalenced Node Array	50
4.1.6	On-node Image Index	51
4.2	Basic Concepts	51
4.2.1	Examples	51
4.3	<code>coarray</code> Directive	52
4.3.1	Purpose and Form of the <code>coarray</code> Directive	52
4.3.2	An Example of the <code>coarray</code> Directive	53
4.4	<code>image</code> Directive	54
4.4.1	Purpose and Form of the <code>image</code> Directive	54
4.4.2	An Example of the <code>image</code> Directive	54
4.5	Image Index Translation Intrinsic Procedures	55
4.5.1	Translation to the Primary Image Index	55
4.5.2	Translation to the Current Image Index	56
4.6	Examples of Communication between Tasks	56
4.7	[C] Coarrays in XcalableMP C.	59
4.7.1	[C] Declaration of Coarrays	59
4.7.2	[C] Reference of Coarrays	60
4.7.3	[C] Synchronization of Coarrays	60
4.8	Directives for the Local-view Programming	61
4.8.1	[F] <code>local_alias</code> Directive	61
4.8.2	<code>post</code> Construct	64
4.8.3	<code>wait</code> Construct	65
4.8.4	[C] <code>lock/unlock</code> Construct	66
5	Base Language Extensions in XcalableMP C	69
5.1	Array Section Notation	69
5.2	Array Assignment Statement	70
5.3	Built-in Functions for Array Section	71
5.4	Pointer to Global Data	71
5.4.1	Name of Global Array	71
5.4.2	The Address-of Operator	71
5.5	Dynamic Allocation of Global Data	71
5.6	The Descriptor-of Operator	72

6	Procedure Interfaces	73
6.1	General Rule	73
6.2	Argument Passing Mechanism in XcalableMP Fortran	73
6.2.1	Sequence Association of Global Data	74
6.2.2	Descriptor Association of Global Data	77
6.3	Argument Passing Mechanism in XcalableMP C	80
7	Intrinsic and Library Procedures	85
7.1	[F] Intrinsic Functions	85
7.1.1	xmp_desc_of	85
7.2	System Inquiry Functions	85
7.2.1	xmp_all_node_num	86
7.2.2	xmp_all_num_nodes	86
7.2.3	xmp_node_num	86
7.2.4	xmp_num_nodes	86
7.2.5	xmp_wtime	87
7.2.6	xmp_wtick	87
7.3	Synchronization Functions	87
7.3.1	xmp_test_async	87
7.4	Memory Allocation Functions	88
7.4.1	[C] xmp_malloc	88
7.5	Mapping Inquiry Functions	88
7.5.1	xmp_nodes_ndims	88
7.5.2	xmp_nodes_index	89
7.5.3	xmp_nodes_size	89
7.5.4	xmp_nodes_attr	90
7.5.5	xmp_nodes_equiv	90
7.5.6	xmp_template_fixed	91
7.5.7	xmp_template_ndims	91
7.5.8	xmp_template_lbound	92
7.5.9	xmp_template_ubound	92
7.5.10	xmp_dist_format	93
7.5.11	xmp_dist_blocksize	93
7.5.12	xmp_dist_gblockmap	94
7.5.13	xmp_dist_nodes	94
7.5.14	xmp_dist_axis	95
7.5.15	xmp_align_axis	95
7.5.16	xmp_align_offset	96
7.5.17	xmp_align_replicated	96
7.5.18	xmp_align_template	97
7.5.19	xmp_array_ndims	97
7.5.20	xmp_array_lshadow	97
7.5.21	xmp_array_ushadow	98
7.5.22	xmp_array_lbound	98
7.5.23	xmp_array_ubound	99
7.6	[F] Array Intrinsic Functions of the Base Language	99
7.7	[C] Built-in Elemental Functions	100
7.8	Intrinsic/Built-in Transformational Procedures	101
7.8.1	xmp_scatter	101
7.8.2	xmp_gather	101

7.8.3	xmp_pack	101
7.8.4	xmp_unpack	102
7.8.5	xmp_transpose	102
7.8.6	xmp_matmul	102
7.8.7	xmp_sort_up	103
7.8.8	xmp_sort_down	103
Bibliography		104
A Programming Interface for MPI		105
A.1	xmp_get_mpi_comm	105
A.2	xmp_init_mpi	105
A.3	xmp_finalize_mpi	106
B Interface to Numerical Libraries		107
B.1	Design of the Interface	107
B.2	Extended Mapping Inquiry Functions	107
B.2.1	xmp_array_gtol	108
B.2.2	xmp_array_lsize	108
B.2.3	xmp_array_laddr	109
B.2.4	xmp_array_lead_dim	109
B.3	Example	109
C Memory-layout Model		113
D XcalableMP I/O		115
D.1	Categorization of I/O	115
D.1.1	Local I/O	115
D.1.2	Master I/O[F]	115
D.1.3	Global I/O	115
D.2	File Connection	116
D.2.1	File Connection in Local I/O	117
D.2.2	[F] File Connection in Master I/O	117
D.2.3	File Connection in Global I/O	117
D.3	Master I/O	117
D.3.1	master_io Construct	118
D.4	[F] Global I/O	119
D.4.1	Global I/O File Operation	120
D.4.2	Collective Global I/O Statement	122
D.4.3	Atomic Global I/O Statement	122
D.4.4	Direct Global I/O Statement	123
D.5	[C] Global I/O Library	123
D.5.1	Global I/O File Operation	126
D.5.2	Collective Global I/O Functions	128
D.5.3	Atomic Global I/O Functions	130
D.5.4	Direct Global I/O Functions	131
E Sample Programs		133

List of Figures

2.1	Hardware Model	3
2.2	Parallelization by the Global-view Programming Model	5
2.3	Local-view Programming Model	6
2.4	Global View and Local View	7
3.1	Example of Shadow of a Two-dimensional Array	26
3.2	Example of Periodic Shadow Reflection	41
6.1	Sequence Association with a Global Dummy Argument	75
6.2	Sequence Association with a Local Dummy Argument	76
6.3	Sequence Association of a Section of a Global Data as an Actual Argument with a Local Dummy Argument	77
6.4	Sequence Association of an Element of a Global Data as an Actual Argument with a Local Dummy Argument	78
6.5	Sequence Association with a Global Dummy Argument that Has Full Shadow	78
6.6	Descriptor Association with a Global Dummy Argument	80
6.7	Descriptor Association with a Local Dummy Argument	81
6.8	Passing to a Global Dummy Argument	82
6.9	Passing to a Local Dummy Argument	83
6.10	Passing an Element of a Global Data as an Actual Argument to a Local Dummy Argument	83
B.1	Invocation of a Library Routine through an Interface Procedure	107
C.1	Example of Memory Layout in the Omni XcalableMP compiler	114

List of Tables

7.1	Built-in Elemental Functions in XcalableMP C	100
D.1	Global I/O	116
D.2	Operations for I/O	119

Acknowledgment

The specification of XcalableMP is designed by the XcalableMP Specification Working Group, which consists of the following members from academia, research laboratories, and industries.

- Tatsuya Abe RIKEN
- Tokuro Anzaki Hitachi
- Taisuke Boku University of Tsukuba
- Toshio Endo TITECH
- Yoshinari Fukui JAMSTEC
- Yasuharu Hayashi NEC
- Atsushi Hori RIKEN
- Kohichiro Hotta Fujitsu
- Hidetoshi Iwashita Fujitsu
- Susumu Komae AXE
- Atsushi Kubota Hiroshima City University
- Jinpil Lee University of Tsukuba
- Toshiyuki Maeda RIKEN
- Motohiko Matsuda RIKEN
- Yuichi Matsuo JAXA
- Kazuo Minami RIKEN
- Shoji Morita AXE
- Hitoshi Murai RIKEN
- Kengo Nakajima University of Tokyo
- Takashi Nakamura JAXA
- Tomotake Nakamura RIKEN
- Mamoru Nakano CRAY
- Masahiro Nakao University of Tsukuba
- Takeshi Nanri Kyusyu University
- Kiyoshi Negishi Hitachi
- Satoshi Ohshima University of Tokyo
- Yasuo Okabe Kyoto University
- Hitoshi Sakagami NIFS
- Tomoko Sakari Fujitsu
- Shoich Sakon NEC
- Mitsuhisa Sato University of Tsukuba
- Taizo Shimizu PC Cluster Consortium
- Takenori Shimosaka RIKEN
- Yoshihisa Shizawa RIST

- Shozo Takeoka AXE
- Hitoshi Uehara JAMSTEC
- Masahiro Yasugi Kyoto University
- Mitsuo Yokokawa RIKEN

This work was supported by “Seamless and Highly-productive Parallel Programming Environment for High-performance Computing” project funded by Ministry of Education, Culture, Sports, Science and Technology, Japan, and is supported by PC Cluster Consortium.

Chapter 1

Introduction

This document defines the specification of XcalableMP, a directive-based language extension of Fortran and C for scalable and performance-aware parallel programming. The specification includes a collection of compiler directives and intrinsic and library procedures, and provides a model of parallel programming for distributed memory multiprocessor systems.

1.1 Features of XcalableMP

The features of XcalableMP are summarized as follows:

- XcalableMP supports typical parallelization based on the data-parallel paradigm and work mapping under “global-view” programming model, and enables parallelizing the original sequential code using minimal modification with simple directives, like OpenMP [1]. Many ideas on “global-view” programming are inherited from High Performance Fortran (HPF) [2].
- The important design principle of XcalableMP is “performance-awareness.” All actions of communication and synchronization are taken by directives (and coarray features), which is different from automatic parallelizing compilers. The user should be aware of what happens by the XcalableMP directives in the execution model on the distributed memory architecture.
- XcalableMP also includes features from Partitioned Global Address Space (PGAS) languages, such as coarray of the Fortran 2008 standard, for the “local-view” programming.
- Extension of existing base languages with directives is useful to reduce code-rewriting and education costs. The XcalableMP language specification is defined on Fortran or C as a base language.
- For flexibility and extensibility, the execution model allows to combine with explicit Message Passing Interface (MPI) [3] coding for more complicated and tuned parallel codes and libraries.
- For multi-core and SMP clusters, OpenMP directives can be combined into XcalableMP for thread programming inside each node as a hybrid programming model.

XcalableMP is being designed based on experiences obtained in the development of HPF, HPF/JA [4], Fujitsu XPF (VPP FORTRAN) [5, 6], and OpenMPD [7].

1.2 Scope

The XcalableMP specification covers only user-directed parallelization, wherein the user explicitly specifies the behavior of the compiler and the runtime system in order to execute the program in parallel in a distributed-memory system. XcalableMP-compliant implementations are not required to automatically lay out data, detect parallelism and parallelize loops, or generate communications and synchronizations.

1.3 Organization of this Document

The remainder of this document is structured as follows:

- Chapter 2: Overview of the XcalableMP Model and Language
- Chapter 3: Directives
- Chapter 4: Support for the Local-view Programming
- Chapter 5: Base Language Extensions in XcalableMP C
- Chapter 6: Procedure Interface
- Chapter 7: Intrinsic and Library Procedures

In addition, the following appendices are included in this document as proposals.

- Appendix A: Programming Interface for MPI
- Appendix B: Interface to Numerical Libraries
- Appendix C: Memory-layout Model
- Appendix D: XcalableMP I/O

1.4 Changes from Version 1.0

- The concept of the node array and the node set is reorganized.
- Mapping inquiry procedures are expanded and moved from the appendix to the core specification.
- The specification on coarrays is improved significantly and some image control directives in XMP/C are defined.
- The appendix on a directive for thread parallelism is deleted.
- The proposal on XcalableMP I/O is changed slightly and adopted.
- etc.

001
002
003
004
005
006
007
008
009
010
011
012
013
014
015
016
017
018
019
020
021
022
023
024
025
026
027
028
029
030
031
032
033
034
035
036
037
038
039
040
041
042
043
044
045
046
047
048
049
050
051
052
053
054
055
056
057

Chapter 2

Overview of the XcalableMP Model and Language

2.1 Hardware Model

The target of XcalableMP is distributed-memory multicomputers (Figure 2.1). Each computation node, which may contain several cores, has its own local memory (shared by the cores, if any), and is connected with each other via an interconnection network. Each node can access its local memory directly and remote memory, that is, the memory of another node indirectly (i.e. via communication). However, it is assumed that accessing remote memory is much slower than accessing local memory.

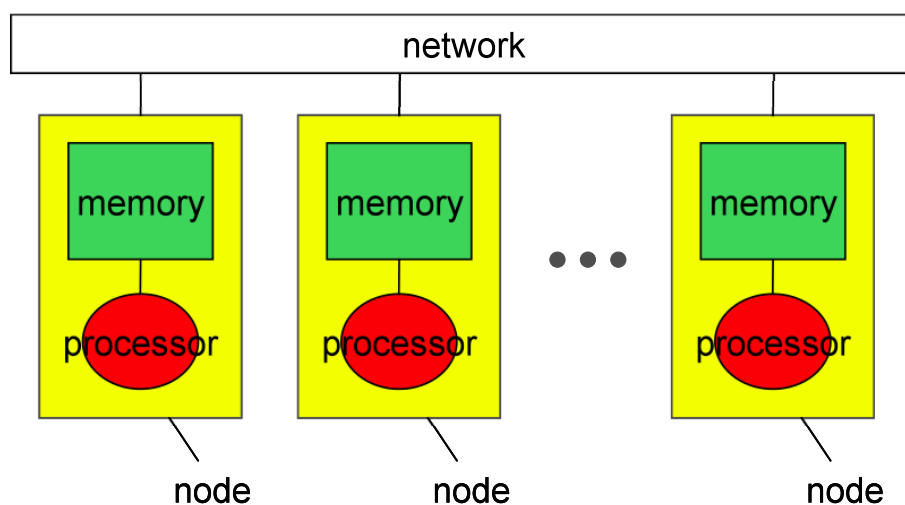

Figure 2.1: Hardware Model

2.2 Execution Model

An XcalableMP program execution is based on the Single Program Multiple Data (SPMD) model, where each node starts execution from the same main routine and keeps executing the same code independently (i.e. asynchronously), which is referred to as the *replicated execution*, until it encounters an XcalableMP construct.

001 A set of nodes that executes a procedure, a statement, a loop, a block, etc. is referred to as its
002 *executing node set* and determined by the innermost **task**, **loop** or **array** directive surrounding
003 it dynamically, or at runtime. The *current executing node set* is an executing node set of the
004 current context, which is managed by the XcalableMP runtimes system on each node.

005 The current executing node set at the beginning of the program execution, or *primary*
006 *node set*, is a node set that contains all the available nodes, which can be specified in an
007 implementation-dependent way (e.g. through a command-line option).

008 When a node encounters at runtime either a **loop**, **array**, or **task** construct, and is contained
009 by the node set specified by the **on** clause of the directive, it updates the current executing node
010 set with the specified one and executes the body of the construct, after which it resumes the
011 last executing node set and proceeds to execute the following statements.

012 Particularly when a node in the current executing node set encounters a **loop** or an **array**
013 construct, it executes the loop or the array assignment in parallel with other nodes, so that each
014 iteration of the loop or element of the assignment is independently executed by the node where
015 a specified data element resides.

016 When a node encounters a synchronization or a communication directive, synchronization
017 or communication occurs between it and other nodes. That is, such *global constructs* are per-
018 formed collectively by the current executing nodes. Note that neither synchronizations nor
019 communications occur without these constructs specified.

023 2.3 Data Model

024 There are two classes of data in XcalableMP: *global data* and *local data*. Data declared in an
025 XcalableMP program are local by default.

026 Global data are ones that are distributed onto the executing node set by the **align** directive
027 (see section 3.3.4). Each fragment of a global data is allocated in the local memory of a node in
028 the executing node set.

029 Local data are all of the ones that are not global. They are replicated in the local memory
030 of each of the executing nodes.

031 A node can access directly only local data and sections of global data that are allocated in
032 its local memory. To access data in remote memory, explicit communication must be specified
033 in such ways as the global communication constructs and the coarray assignments.

034 Particularly in XcalableMP Fortran, for common blocks that include any global variables,
035 the ways how the storage sequence of them is defined and how the storage association of them
036 is resolved are implementation-dependent.

042 2.4 Global-view Programming Model

043 The global-view programming model is useful when, starting from a sequential version of a
044 program, the programmer parallelizes it in data-parallel style by adding directives with minimum
045 modification. In the global-view programming model, the programmer describes the distribution
046 of the data among nodes using the data distribution directives. The **loop** construct assigns
047 each iteration of a loop to the node where the computed data is located. The global-view
048 communication directives are used to synchronize nodes, to maintain the consistency of the
049 shadow area, and to move part of the distributed data globally. Note that the programmer
050 must specify explicitly communications to make all data reference in the program local by using
051 appropriate directives.

052 In many cases, the XcalableMP program according to the global-view programming model is
053 based on a sequential program and can produce the same results as it, regardless of the number
054
055
056
057

of nodes (Figure 2.2).

There are three groups of directives for the global-view programming model. Since these directives are ignored as a comment by the compilers of base languages (Fortran and C), an XcalableMP program can be compiled by them to run properly.

Data Mapping

Specifies the data distribution and mapping to nodes (partially inherited from HPF).

Work Mapping (Parallelization)

Assigns a work to a node set. The `loop` construct maps each iteration of a loop to nodes owning a specified data elements. The `task` construct defines an amount of work as a *task* and assigns it to a specified node set.

Communication and Synchronization

Specifies how to communicate and synchronize with the other compute nodes. In XcalableMP, inter-node communication must be explicitly specified by the programmer. The compiler guarantees that no communication occurs unless it is explicitly specified by the programmer.

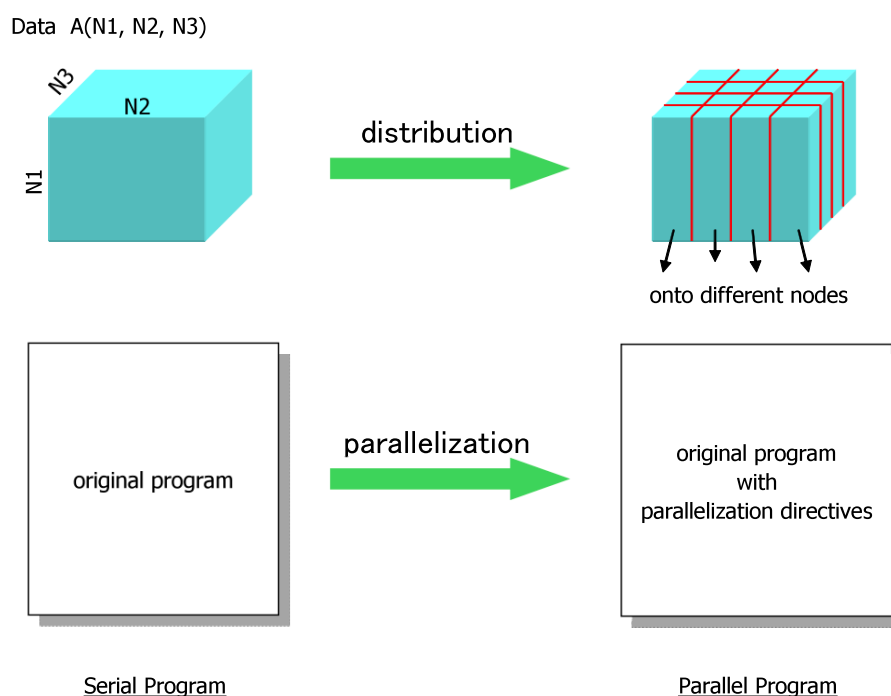

Figure 2.2: Parallelization by the Global-view Programming Model

2.5 Local-view Programming Model

The local-view programming model is suitable for programs that explicitly describe an algorithm and remote data reference that are to be done by each node (Figure 2.3).

For the local-view programming model, some language extensions and directives are provided. The coarray notation imported from Fortran 2008 is one of such extensions and can be used to

specify which replica of a local data is to be accessed. For example, the expression of $A(i) [N]$ is used to access an array element of $A(i)$ located on the node N . If the access is a reference, then communication to obtain the value from remote memory (i.e. *get* operation) occurs. If the access is a definition, then communication to set a value to remote memory (i.e. *put* operation) occurs.

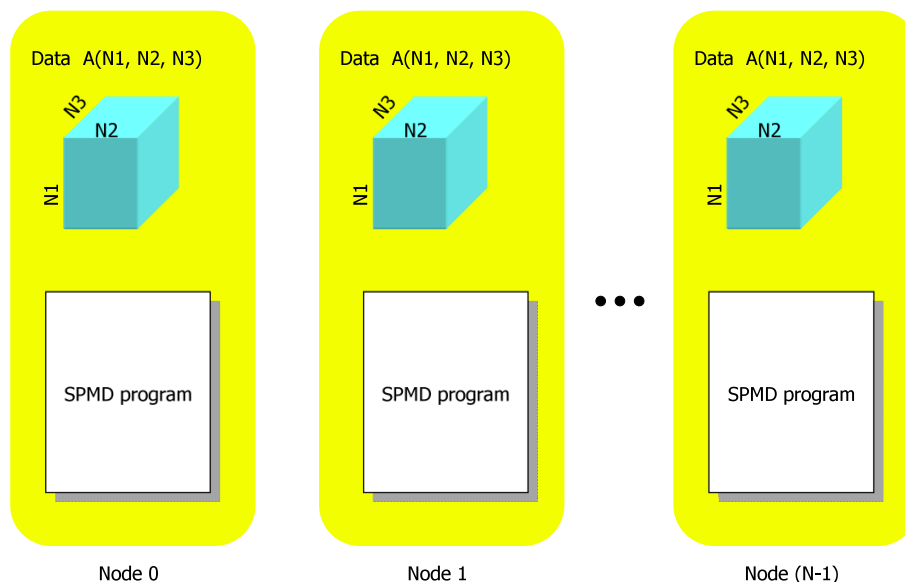

Figure 2.3: Local-view Programming Model

2.6 Interactions between the Global View and the Local View

In the global view, nodes are used to distribute data and computational load. In the local view, nodes are used to address data in the coarray notation. In the application program, programmers should choose an appropriate data model according to the structure of the program. Figure 2.4 illustrates the global view and the local view of data.

Data may have both a global view and a local view, and can be accessed from either. XcalableMP provides some directives to give the local name (alias) to the global data declared in the global-view programming model so that they can be accessed also in the local-view programming model. This feature is useful to optimize a certain part of the program by using explicit remote data access in the local-view programming model.

2.7 Base Languages

The XcalableMP language specification is defined on Fortran or C as a base language. More specifically, the base language of XcalableMP Fortran is Fortran 90 or later, and that of XcalableMP C is ISO C90 (ANSI C89) or later.

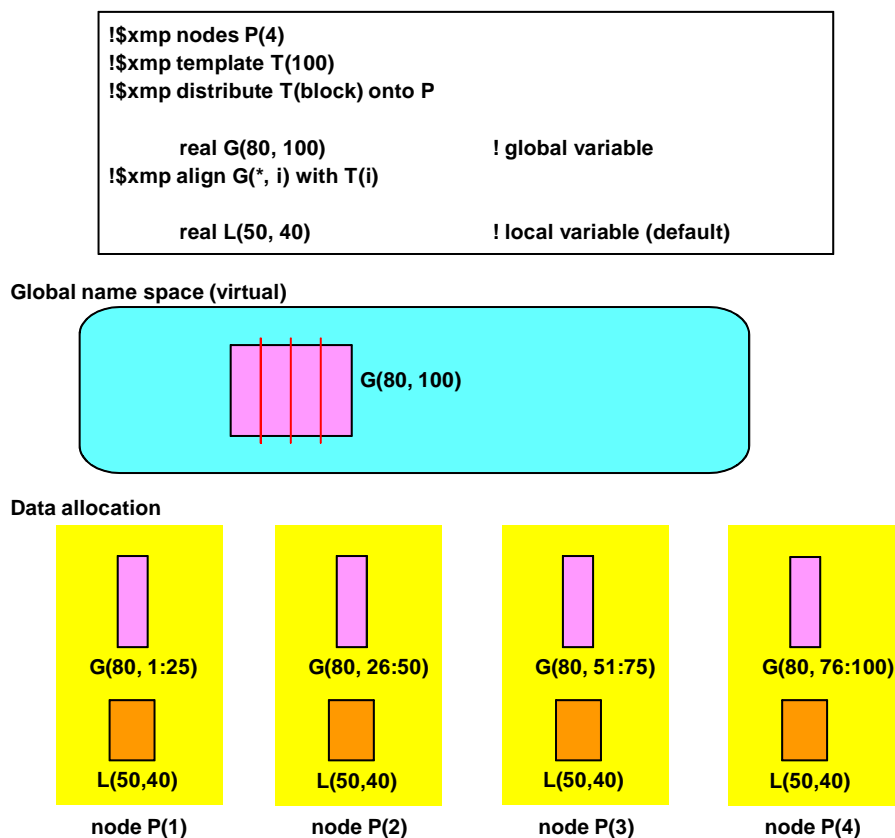

Figure 2.4: Global View and Local View

2.8 Glossary

2.8.1 Language Terminology

base language A programming language that serves as the foundation of the XcalableMP specification.

base program A program written in a base language.

XcalableMP

Fortran The XcalableMP specification for a base language Fortran, abbreviated as XMP/F.

XcalableMP C The XcalableMP specification for a base language C, abbreviated as XMP/C.

structured block For C, an executable statement, possibly compound, with a single entry at the top and a single exit at the bottom, or an XcalableMP construct. For Fortran, a block of executable statements with a single entry at the top and a single exit at the bottom, or an XcalableMP construct.

procedure A generic term used to refer to “procedure” (including subroutine and function) in XcalableMP Fortran and “function” in XcalableMP C.

directive In XcalableMP Fortran, a comment, and in XcalableMP C, a `#pragma`, that specifies XcalableMP program behavior.

001
002
003
004
005
006
007
008
009
010
011
012
013
014
015
016
017
018
019
020
021
022
023
024
025
026
027
028
029
030
031
032
033
034
035
036
037
038
039
040
041
042
043
044
045
046
047
048
049
050
051
052
053
054
055
056
057

declarative

directive An XcalableMP directive that may only be placed in a declarative context. A declarative directive has no associated executable user code, but instead has one or more associated user declarations.

executable

directive An XcalableMP directive that is not declarative; it may be placed in an executable context.

construct An XcalableMP executable directive (and for Fortran, the paired **end** directive, if any) and the associated statement, loop or structured block, if any.

global construct A construct that is executed collectively and synchronously by every node in the current executing node set. Global constructs are further classified into two groups of *global communication constructs*, such as **gmove**, **barrier**, etc., which specify communication or synchronization, and *work mapping constructs*, such as **loop**, **array** and **tasks**, which specify parallelization of loops, array assignments or tasks.

template A dummy array that represents an index space to be distributed onto a node set, which serves as the “template” of parallelization in XcalableMP and can be considered to abstract, for example, a set of grid points in the grid method or particles in the particle method. A template is used in an XcalableMP program to specify the data and work mapping. Note that the lower bound of each dimension of a template is one in both XcalableMP Fortran and XcalableMP C.

data mapping Allocating elements of an array to nodes in a node set by specifying with the **align** directive that the array is aligned with a distributed template.

work mapping Assigning each of the iterations of a loop, the elements of an array assignment, or the tasks to nodes in a node set. Such work mapping is specified by aligning it with a template or distributing it onto a node set.

global A data or a work is *global* if and only if there is one or more replicated instances of it each of which is shared by the executing nodes.

local A data or a work is *local* if and only if there is a replicated instance of it on each of the executing nodes.

global-view

model A model of programming or parallelization, on which parallel programs are written by specifying how to map global data and works onto nodes.

local-view model A model of programming or parallelization, on which parallel programs are written by specifying how each node owns local data and does local works.

2.8.2 Node Terminology

node An execution entity managed by the XcalableMP runtime system, which has its own memory and can communicate with other nodes. A node can execute one or more threads concurrently.

node set	A totally ordered set of nodes.	001
entire node set	A node set that contains all of the nodes participating in the execution of an XcalableMP program.	002 003 004
primary node set	An entire node set that is specified explicitly or implicitly, and is the current executing node set at the beginning of the program execution.	005 006 007
executing node set	A node set that contains all of the nodes participating in the execution of a procedure, a statement, a construct, etc. of an XcalableMP program is called its executing node set. This term is used in this document to represent the <i>current executing node set</i> unless it is ambiguous. Note that the executing node set of the main routine is the primary node set.	008 009 010 011 012 013 014 015
current executing node set	An executing node set of the current context, which is managed by the XcalableMP runtimes system. The current executing node set can be modified by the <code>task</code> , <code>array</code> , or <code>loop</code> constructs.	016 017 018 019 020 021 022
executing node	A node in the executing node set.	023 024
node array	An XcalableMP entity of the same form as a Fortran array that represents a node set in XcalableMP programs. Each element of a node array represents a node in the corresponding node set. A node array is declared by the <code>nodes</code> directive. Note that the lower bound of each dimension of a node array is one in both XcalableMP Fortran and XcalableMP C.	025 026 027 028 029 030 031
non-primary node array	A node array declared without “= <i>node-ref</i> ”, “=**”, or “=*” in a <code>NODES</code> directive. A non-primary node array corresponds to all the nodes at the invocation of a program, and also corresponds to all the images at the invocation of a program.	032 033 034 035 036 037
primary node array	A node array declared with the rhs of a node reference by “**” representing the primary node set. A primary node array corresponds to all the nodes at the invocation of a program, and also corresponds to all the images at the invocation of a program.	038 039 040 041 042 043
executing node array	A node array declared with the rhs of a node reference by “*” representing the executing node set. An executing node array corresponds to the executing node set, and also corresponds to the current set of images at the evaluation of the declaration of the node array.	044 045 046 047 048 049
parent node set	The parent node set of a node set is the last executing node set, which encountered the innermost <code>task</code> , <code>loop</code> , or <code>array</code> construct that is being executed.	050 051 052 053
node number	A unique number assigned to each node in a node set, which starts from one and corresponds to its position within the node set which is totally ordered.	054 055 056 057

2.8.3 Data Terminology

variable A named data storage block, whose value can be defined and redefined during the execution of a program. Note that *variables* include array sections.

global data An array that is aligned with a template. Elements of a global data are distributed onto nodes according to the distribution of the template. As a result, each node owns a part of a global data (called a *local section*), and can access directly it but cannot those on the other nodes.

local data Data that is not global. Each node owns a replica of a local data, and can access directly it but cannot those on the other nodes. Note that the replicas of a local data do not always have the same value.

replicated data A data whose storage is allocated on multiple nodes. A replicated data is either a local data or a global data replicated by an `align` directive.

distribution Assigning each element of a template to nodes in a node set in a specified manner. In the broad sense, it means that of an array, a loop, etc.

alignment Associating each element of an array, a loop, etc. with an element of the specified template. An element of the aligned array, a loop, etc. is necessarily mapped to the same node as its associated element of the template.

local section A section of a global data that is allocated as an array on each node at runtime. The local section of a global data includes its shadow objects.

shadow An additional area of the local section of a distributed array, which is used to keep elements to be moved in from neighboring nodes.

2.8.4 Work Terminology

task A specific instance of executable codes that is defined by the `task` construct and executed by a node set specified by its `on` clause.

2.8.5 Communication and Synchronization Terminology

communication A data movement among nodes. Communication in XcalableMP occurs only when the programmer instruct it explicitly with a global communication construct or a coarray reference.

reduction A procedure of combining variables from each node in a specified manner and returning the result value. A reduction always involves communication. A reduction is specified by either the `on` clause of the `loop` construct or the `reduction` construct.

synchronization Synchronization is a mechanism to ensure that multiple nodes do not execute specific portions of a program at the same time. Synchronization among any number of nodes is specified by the `barrier` construct and that between two nodes by the `post` and `wait` constructs.

asynchronous communication Communication that does not block and returns before it is complete. Thus statements that follow it can overtake it. An asynchronous communication is specified by the `async` clause of global communication constructs or the `async` directive for a coarray reference.

2.8.6 Local-view Terminology

local alias An alias to the local section of a global data, that is, a distributed array. A local alias can be used in XcalableMP programs in the same way as normal local data.

current set of

images The current set of images is a set of images determined by the most lately executed *task-directive* in the TASK directive constructs that are not completed if any TASK directive constructs are being executed. The current set of images is all the images at the invocation of a program if there are no TASK directive constructs that are not completed.

image An instance of an XcalableMP program. Each image uniquely corresponds to a node.

image index An integer value identifying an image in a set of images.

In XcalableMP C, the lower cobound in each axis is one by default and taking account of the cobound, the cosubscript list in an image selector determines the image index in the same way that a subscript list in an array element determines the subscript order value in Fortran, taking account of the bounds.

001
002
003
004
005
006
007
008
009
010
011
012
013
014
015
016
017
018
019
020
021
022
023
024
025
026
027
028
029
030
031
032
033
034
035
036
037
038
039
040
041
042
043
044
045
046
047
048
049
050
051
052
053
054
055
056
057

001
002
003
004
005
006
007
008
009
010
011
012
013
014
015
016
017
018
019
020
021
022
023
024
025
026
027
028
029
030
031
032
033
034
035
036
037
038
039
040
041
042
043
044
045
046
047
048
049
050
051
052
053
054
055
056
057

Chapter 3

Directives

This chapter describes the syntax and behavior of XcalableMP directives. In this document, the following notation is used to describe XcalableMP directives.

- `xxx` **type-face** characters are used to indicate literal type characters.
- `xxx...` If the line is followed by "...", then `xxx` can be repeated.
- `[xxx]` `xxx` is optional.
- The syntax rule continues.
- [F] The following lines are effective only in XcalableMP Fortran.
- [C] The following lines are effective only in XcalableMP C.

3.1 Directive Format

3.1.1 General Rule

In XcalableMP Fortran, XcalableMP directives are specified using special comments that are identified by unique sentinels `!$xmp`. An XcalableMP directive follows the rules for comment lines of either the Fortran free or fixed source form, depending on the source form of the surrounding program unit¹. XcalableMP Fortran directives are case-insensitive.

[F] `!$xmp directive-name clause`

In XcalableMP C, XcalableMP directives are specified using the `#pragma` mechanism provided by the C standards. XcalableMP C directives are case-sensitive.

[C] `#pragma xmp directive-name clause`

Directives are classified as *declarative directives* and *executable directives*.

The declarative directive is a directive that may only be placed in a declarative context. A declarative directive has no associated executable user code. The scope rule of declarative directives obeys that of the declaration statements in the base language. For example, in XcalableMP Fortran, a node array declared by a `nodes` directive is visible only within either the program unit, the derived-type declaration or the interface body that immediately surrounds the directives, unless overridden in the inner blocks or use or host associated, and, in XcalableMP C, a node array declared by a `nodes` directive is visible only in the range from the declaring point to

¹Consequently, the rules of comment lines that an XcalableMP directive follows is the same as the ones that an OpenMP directive follows.

the end of the block when placed within a block, or of the file when placed outside any blocks, unless overridden in the inner blocks.

Note that, in XcalableMP Fortran, node arrays and templates in other scoping unit are accessible by use or host association.

The following directives are declarative directives.

- `nodes`
- `template`
- `distribute`
- `align`
- `shadow`
- `coarray`

The executable directives are placed in an executable context. A stand-alone directive is an executable directive that has no associated user code, such as a `barrier` directive. An executable directive and its associated user code make up an XcalableMP construct, as in the following format:

```
[F]  !$xmp directive-name clause ...
      structured-block

[C]  #pragma xmp directive-name clause ...
      structured-block
```

Note that, in XcalableMP Fortran, a corresponding `end` directive is required for some executable directives such as `task` and `tasks` and, in XcalableMP C, the associated statement can be compound.

The following directives are executable directives.

- `template_fix`
- `task`
- `tasks`
- `loop`
- `array`
- `reflect`
- `gmove`
- `barrier`
- `reduction`
- `bcast`
- `wait_async`

3.1.2 Combined Directive

Synopsis

For XcalableMP Fortran, multiple attributes can be specified in one combined declarative directive, which is analogous to type declaration statements in Fortran using the “:” punctuation.

Syntax

```
[F] !$xmp combined-directive is combined-attribute [, combined-attribute]... ::
                                     combined-decl [, combined-decl]...
```

combined-attribute is one of:

```
nodes
template
distribute (dist-format [, dist-format]... ) onto nodes-name
align ( align-source [, align-source]... ) ■
                                     ■ with template-name (align-subscript [, align-subscript]... )
shadow ( shadow-width [, shadow-width]... )
dimension ( explicit-shape-spec [, explicit-shape-spec]... )
```

and *combined-decl* is one of:

```
nodes-decl
template-decl
array-name
```

Description

A combined directive is interpreted as if an object corresponding to each *combined-decl* is declared in a directive corresponding to each *combined-attribute*, where all restrictions of each directive, in addition to the following ones, are applied.

Restrictions

- The same kind of *combined-attribute* must not appear more than once in a given *combined-directive*.
- If the **nodes** attribute appears in a *combined-directive*, each *combined-decl* must be a *nodes-decl*.
- If the **template** or **distribute** attribute appears in a *combined-directive*, each *combined-decl* must be a *template-decl*.
- If the **align** or **shadow** attribute appears in a *combined-directive*, each *combined-decl* must be an *array-name*.
- If the **dimension** attribute appears in a *combined-directive*, any object to which it applies must be declared with either the **template** or the **nodes** attribute.

3.2 nodes Directive

Synopsis

The **nodes** directive declares a named node array.

Syntax

[F] `!$xmp nodes nodes-decl [, nodes-decl]...`

[C] `#pragma xmp nodes nodes-decl [, nodes-decl]...`

where *nodes-decl* is one of:

nodes-name (*nodes-spec* [, *nodes-spec*]...)

nodes-name (*nodes-spec* [, *nodes-spec*]...) = *nodes-ref*

and *nodes-spec* must be one of:

int-expr

*

Description

The `nodes` directive declares a node array that corresponds to a node set.

The first form of the `nodes` directive is used to declare a node array that corresponds to the entire node set. The second form is used to declare a node array, each node of which is assigned to a node of the node set specified by *nodes-ref* at the corresponding position in Fortran's array element order, as if the node set were a one-dimensional node array.

If *node-size* in the last dimension is "*", then the size of the node array is automatically adjusted according to the total size of the entire node set in the first form, the executing node set in the second form, or the referenced node set in the third form.

Restrictions

- *nodes-name* must not conflict with any other local name in the same scoping unit.
- *nodes-spec* can be "*" only in the last dimension.
- *nodes-ref* must not reference *nodes-name* either directly or indirectly.
- If no *nodes-spec* is "*", then the product of all *nodes-spec* must be equal to the total size of the entire node set in the first form, the executing node set in the second form, or the referenced node set in the third form.
- *nodes-subscript* in *nodes-ref* must not be "*".

Examples

The following are examples of the first and the third forms appeared in the main program. Since the node array `p`, which corresponds to the entire node set, is declared to be of size 16, this program must be executed by 16 nodes.

XcalableMP Fortran	XcalableMP C
<pre> program main !\$xmp nodes p(16) !\$xmp nodes q(4,*) !\$xmp nodes r(8)=p(3:10) !\$xmp nodes z(2,3)=(1:6) ... end program </pre>	<pre> int main() { #pragma xmp nodes p(16) #pragma xmp nodes q(4,*) #pragma xmp nodes r(8)=p(3:10) #pragma xmp nodes z(2,3)=(1:6) ... } </pre>

The following is an example of a node declaration in a procedure. Since `p` is declared in the second form to be of size 16 and corresponds to the executing node set, the invocation of the `foo` function must be executed by 16 nodes. The node array `q` is declared in the first form and corresponds to the entire node set. The node array `r` is declared as a subset of `p`, and `x` as a subset of `q`.

```

                                XcalableMP Fortran
function foo()
!$xmp nodes p(16)=*
!$xmp nodes q(4,*)
!$xmp nodes r(8)=p(3:10)
5 !$xmp nodes x(2,3)=q(1:2,1:3)
    ...
end function
```

3.2.1 Node Reference

Synopsis

The node reference is used to reference a node set.

Syntax

A node reference *nodes-ref* is specified by either the name of a node array, the “*” symbol or “**”.

```

nodes-ref  is  nodes-name [nodes-subscript [, nodes-subscript ]... ]
              or  *
              or  **
```

where *nodes-subscript* must be one of:

```

int-expr
triplet
*
```

Description

A node reference by *nodes-name* represents a node set corresponding to the node array specified by the name or its subarray, which is totally ordered in Fortran’s array element order. A node reference by “*” represents the executing node set. A node reference by “**” represents the primary node set.

Specifically, the “*” symbol appeared as *nodes-subscript* in a dimension of *nodes-ref* is interpreted by each node at runtime as its position (coordinate) in the dimension of the referenced node array. Thus, a node reference `p(s1, ..., sk-1, *, sk+1, ..., sn)` is interpreted as `p(s1, ..., sk-1, jk, sk+1, ..., sn)` on the node `p(j1, ..., jk-1, jk, jk+1, ..., jn)`.

Note that “*” can be used only as the node reference in the `on` clause of some executable directives.

Examples

Assume that `p` is the name of a node array and that `m` is an integer variable.

- 001 • As a target node array in the `distribute` directive,
002 `!$xmp distribute a(block) onto p`
003
- 004
- 005 • To specify a node set to which the declared node array corresponds in the second form of
006 the `nodes` directive,
007 `!$xmp nodes r(2,2,4) = p(1:4,1:4)`
008 `!$xmp nodes r(2,2,4) = (1:16)`
009
- 010
- 011 • To specify a node array that corresponds to the executing node set of a task in the `task`
012 directive,
013 `!$xmp task on p(1:4,1:4)`
014 `!$xmp task on (1:16)`
015 `!$xmp task on p(:,*)`
016 `!$xmp task on (m)`
017
- 018
- 019 • To specify a node array with which iterations of a loop are aligned in the `loop` directive,
020 `!$xmp loop (i) on p(lb(i):lb(i+1)-1)`
021
- 022
- 023 • To specify a node array that corresponds to the executing node set in the `barrier` and
024 the `reduction` directive,
025 `!$xmp barrier on p(5:8)`
026 `!$xmp reduction (+:a) on p(*,:)`
027
- 028
- 029 • To specify the source node and the node array that corresponds to the executing node set
030 in the `bcast` directive,
031 `!$xmp bcast (b) from p(k) on p(:)`
032
- 033
- 034

035 3.3 Template and Data Mapping Directives

036 3.3.1 template Directive

037 Synopsis

038 The `template` directive declares a template.

039 Syntax

040 [F] `!$xmp template template-decl [, template-decl]...`

041 [C] `#pragma xmp template template-decl [, template-decl]...`

042 where *template-decl* is:

043 `template-name (template-spec [, template-spec]...)`

044 and *template-spec* must be one of:

045 `[int-expr :] int-expr`

046 `:`

Description

The `template` directive declares a template with the shape specified by the sequence of *template-spec*'s. If every *template-spec* is “:”, then the shape of the template is initially undefined. This template must not be referenced until the shape is defined by a `template_fix` directive (see section 3.3.6) at runtime. If *int-expr* is specified as *template-spec*, then the default lower bound is one.

Restrictions

- *template-name* must not conflict with any other local name in the same scoping unit.
- Every *template-spec* must be either *[int-expr :]* *int-expr* or “:”.

3.3.2 Template Reference

Synopsis

The template reference expression specified in the `on` or the `from` clause of some directives is used to indirectly specify a node set.

Syntax

template-ref **is** *template-name* [*(* *template-subscript* [*,* *template-subscript*]*...* *)*]

where *template-subscript* must be one of:

int-expr
triplet
 *

Description

Being specified in the `on` or the `from` clause of some directives, the template reference refers to a subset of a node set where the specified subset of the template resides.

Specifically, the “*” symbol appeared as *template-subscript* in a dimension of *template-ref* is interpreted by each node at runtime as the indices of the elements in the dimension that reside in the node. “*” in a template reference is similar to “*” in a node reference.

Examples

Assume that `t` is a template.

- In the `task` directive, the executing node set of the task can be indirectly specified with a template reference in the `on` clause.

```
!$xmp task on t(1:m,1:n)
!$xmp task on t
```

- In the `loop` directive, the executing node set of each iteration of the following loop is indirectly specified with a template reference in the `on` clause.

```
!$xmp loop (i) on t(i-1)
```

- In the `array` directive, the executing node set on which the following array assignment statement is performed in parallel is indirectly specified with a template reference in the `on` clause.

```
!$xmp array on t(1:n)
```

- In the `barrier`, `reduction`, and `bcast` directives, the node set that is to perform the operation collectively can be indirectly specified with a template reference in the `on` clause.

```
!$xmp barrier on t(1:n)
!$xmp reduction (+:a) on t(*,:)
!$xmp bcast b from p(k) on t(1:n)
```

3.3.3 distribute Directive

Synopsis

The `distribute` directive specifies distribution of a template.

Syntax

```
[F] !$xmp distribute template-name (dist-format [, dist-format]... ) onto nodes-name
```

```
[C] #pragma xmp distribute template-name (dist-format [, dist-format]... ) ■
      ■ onto nodes-name
```

where *dist-format* must be one of:

```
*
block [ ( int-expr ) ]
cyclic [ ( int-expr ) ]
gblock ( { * | int-array } )
```

Description

According to the specified distribution format, a template is distributed onto a specified node array. The dimension of the node array appearing in the `onto` clause corresponds, in left-to-right order, with the dimension of the distributed template for which the corresponding *dist-format* is not “*”.

Let *d* be the size of the dimension of the template, *p* be the size of the corresponding dimension of the node array, `ceiling` and `mod` be Fortran’s intrinsic functions, and each of the arithmetic operators be that of Fortran. The interpretation of *dist-format* is as follows:

“*” The dimension is not distributed.

`block` Equivalent to `block(ceiling(d/p))`.

`block(n)` The dimension of the template is divided into contiguous blocks of size *n*, which are distributed onto the corresponding dimension of the node array. The dimension of the template is divided into *d/n* blocks of size *n*, and one block of size `mod(d,n)` if any, and each block is assigned sequentially to an index along the corresponding dimension of the node array. Note that if $k = p - d/n - 1 > 0$, then there is no block assigned to the last *k* indices.

`cyclic` Equivalent to `cyclic(1)`.

`cyclic(n)` The dimension of the template is divided into contiguous blocks of size `n`, and these blocks are distributed onto the corresponding dimension of the node array in a round-robin manner.

`gblock(m)` `m` is referred to as a mapping array. The dimension of the template is divided into contiguous blocks so that the i 'th block is of size `m(i)`, and these blocks are distributed onto the corresponding dimension of the node array.

If at least one `gblock(*)` is specified in *dist-format*, then the template is initially undefined and must not be referenced until the shape of the template is defined by `template_fix` directives at runtime.

Restrictions

- [C] *template-name* must be declared by a `template` directive that lexically precedes the directive.
- The number of *dist-format* that is not “*” must be equal to the rank of the node array specified by *nodes-name*.
- The size of the dimension of the template specified by *template-name* that is distributed by `block(n)` must be equal to or less than the product of the block size `n` and the size of the corresponding dimension of the node array specified by *nodes-name*.
- The array *int-array* in parentheses following `gblock` must be an integer one-dimensional array, and its size must be equal to the size of the corresponding dimension of the node array specified by *nodes-name*.
- Every element of the array *int-array* in parentheses following `gblock` must have a value of non-negative integer.
- The sum of the elements of the array *int-array* in parentheses following `gblock` must be equal to the size of the corresponding dimension of the template specified by *template-name*.
- [C] A `distribute` directive for a template must precede any its reference in the executable code in the block.

Examples

Example 1

```

_____ XscalableMP Fortran _____
!$xmp nodes p(4)
!$xmp template t(64)
!$xmp distribute t(block) onto p

```

The template `t` is distributed in `block` format, as shown in the following table.

p(1)	t(1:16)
p(2)	t(17:32)
p(3)	t(33:48)
p(4)	t(49:64)

Example 2

```

XcalableMP Fortran
!$xmp nodes p(4)
!$xmp template t(64)
!$xmp distribute t(cyclic(8)) onto p

```

The template `t` is distributed in `cyclic` format of size eight, as shown in the following table.

p(1)	t(1:8) t(33:40)
p(2)	t(9,16) t(41:48)
p(3)	t(17,24) t(49:56)
p(4)	t(25,32) t(57:64)

Example 3

```

XcalableMP Fortran
!$xmp nodes p(8,5)
!$xmp template t(64,64,64)
!$xmp distribute t(*,cyclic,block) onto p

```

The first dimension of the template `t` is not distributed. The second dimension is distributed onto the first dimension of the node array `p` in `cyclic` format. The third dimension is distributed onto the second dimension of `p` in `block` format. The results are as follows:

p(1,1)	t(1:64, 1:57:8, 1:13)
p(2,1)	t(1:64, 2:58:8, 1:13)
...	...
p(8,5)	t(1:64, 8:64:8, 53:64)

Note that the size of the third dimension of `t`, 64, is not divisible by the size of the second dimension of `p`, 5. Thus, sizes of the blocks in the third dimension are different among nodes.

3.3.4 align Directive**Synopsis**

The `align` directive specifies that an array is to be mapped in the same way as a specified template.

Syntax

- ```

[F] !$xmp align array-name (align-source [, align-source]...)
 with template-name (align-subscript [, align-subscript]...)

[C] #pragma xmp align array-name [align-source] [[align-source]]...
 with template-name (align-subscript [, align-subscript]...)

```

where *align-source* must be one of:

*scalar-int-variable*

\*  
:

and *align-subscript* must be one of:

*scalar-int-variable* [ { + | - } *int-expr* ]

\*  
:

Note that the variable *scalar-int-variable* appearing in *align-source* is referred to as an “align dummy variable” and *int-expr* appearing in *align-subscript* as an “align offset.”

### Description

The array specified by *array-name* is aligned with the template specified by *template-name* so that each element of the array indexed by the sequence of *align-source*'s is aligned with the element of the template indexed by the sequence of *align-subscript*'s, where *align-source*'s and *align-subscript*'s are interpreted as follows:

1. The first form of *align-source* and *align-subscript* represents an align dummy variable and an expression of it, respectively. The align dummy variable ranges over all valid index values in the corresponding dimension of the array.
2. The second form “\*” of *align-source* and *align-subscript* represents a dummy variable (not an align dummy variable) that does not appear anywhere in the directive.
  - The second form of *align-source* is said to “collapse” the corresponding dimension of the array. As a result, the index along the corresponding dimension makes no difference in determining the alignment.
  - The second form of *align-subscript* is said to “replicate” the array. Each element of the array is replicated, and aligned to all index values in the corresponding dimension of the template.
3. The third form of *align-source* and the matching *align-subscript* represents a same align dummy variable that ranges over all valid index values in the corresponding dimension of the array. The matching of colons (“:”) in the sequence of *align-source*'s and *align-subscript*'s is determined as follows:
  - [F] Colons in the sequence of *align-source*'s and those in the sequence of *align-subscript*'s are matched up in corresponding left-to-right order, where any *align-source* and *align-subscript* that is not a colon is ignored.
  - [C] Colons in the sequence of *align-source*'s in right-to-left order and those in the sequence of *align-subscript*'s in left-to-right order are matched up, where any *align-source* and *align-subscript* that is not a colon is ignored.

### Restrictions

- [C] *array-name* must be declared by a declaration statement that lexically precedes the directive.
- An align dummy variable may appear at most once in the sequence of *align-subscript*'s.
- An *align-subscript* may contain at most one occurrence of an align dummy variable.

- The *int-expr* in an *align-subscript* may not contain any occurrence of an align dummy variable.
- The sequence of *align-sources*'s must contain exactly as many colons as the sequence of *align-subscript*'s contains.
- [F] The array specified by *array-name* must not appear as an *equivalence-object* in an *equivalence* statement.
- [C] An *align* directive for an array must precede any its appearance in the executable code in the block.

## Examples

### Example 1

```
_____ XcalableMP Fortran _____
!$xmp align a(i) with t(i)
```

The array element  $a(i)$  is aligned with the template element  $t(i)$ . This is equivalent to the following code.

```
_____ XcalableMP Fortran _____
!$xmp align a(:) with t(:)
```

### Example 2

```
_____ XcalableMP Fortran _____
!$xmp align a(*,j) with t(j)
```

The subarray  $a(:,j)$  is aligned with the template element  $t(j)$ . Note that the first dimension of  $a$  is collapsed.

### Example 3

```
_____ XcalableMP Fortran _____
!$xmp align a(j) with t(*,j)
```

The array element  $a(j)$  is replicated and aligned with each template element of  $t(:,j)$ .

### Example 4

```
_____ XcalableMP Fortran _____
!$xmp template t(n1,n2)
 real a(m1,m2)
!$xmp align a(*,j) with t(*,j)
```

The subarray  $a(:,j)$  is aligned with each template element of  $t(:,j)$ .

By replacing “\*” in the first dimension of the array  $a$  and “\*” in the first dimension of the template  $t$  with a dummy variable  $i$  and  $k$ , respectively, this alignment can be interpreted as the following mapping.

$$a(i, j) \rightarrow t(k, j) \mid (i, j, k) \in (1 : n1, 1 : n2, 1 : m1)$$

### 3.3.5 shadow Directive

#### Synopsis

The `shadow` directive allocates the shadow area for a distributed array.

#### Syntax

[F] `!$xmp shadow array-name ( shadow-width [, shadow-width]... )`

[C] `#pragma xmp shadow array-name [shadow-width] [[shadow-width]]...`

where *shadow-width* must be one of:

*int-expr*

*int-expr* : *int-expr*

\*

#### Description

The `shadow` directive specifies the width of the shadow area of an array specified by *array-name*, which is used to communicate the neighbor element of the block of the array. When *shadow-width* is of the form “*int-expr* : *int-expr*,” the shadow area of the width specified by the first *int-expr* is added at the lower bound and that specified by the second one at the upper bound in the dimension. When *shadow-width* is of the form *int-expr*, the shadow area of the same width specified is added at both the upper and lower bounds in the dimension. When *shadow-width* is of the form “\*”, the entire area of the array is allocated on each node, and all of the area that it does not own is regarded as shadow. This type of shadow is sometimes referred to as a “full shadow.”

Note that the shadow area of a multi-dimensional array include “obliquely-neighboring” elements, which are the ones owned by the node whose indices are different in more than one dimension, and that the shadow area can be allocated also at the global lower and upper bound of an array.

The data stored in the storage area declared by the `shadow` directive is referred to as a *shadow object*. A shadow object represents an element of a distributed array and corresponds to the data object that represents the same element as it. The corresponding data object is referred to as the *reflection source* of the shadow object.

#### Restrictions

- [C] *array-name* must be declared by a declaration statement that lexically precedes the directive.
- The value specified by *shadow-width* must be a non-negative integer.
- The number of *shadow-width* must be equal to the number of dimensions (or rank) of the array specified by *array-name*.
- [C] A `shadow` directive for an array must precede any its appearance in the executable code in the block.

## Example

```

001
002
003
004
005 XcalableMP Fortran
006 !$xmp nodes p(4,4)
007 !$xmp template t(64,64)
008 !$xmp distribute t(block,block) onto p
009
010 real a(64,64)
011 !$xmp align a(i,j) with t(i,j)
012 !$xmp shadow a(1,1)
013
014
015
016
017

```

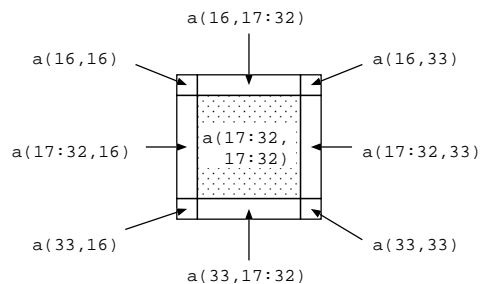

Figure 3.1: Example of Shadow of a Two-dimensional Array

The node  $p(2,2)$  has  $a(17:32,17:32)$  as a data object, and  $a(16,16)$ ,  $a(17:32,16)$ ,  $a(33,16)$ ,  $a(16,17:32)$ ,  $a(33,17:32)$ ,  $a(16,33)$ ,  $a(17:32,33)$  and  $a(33,33)$  as shadow objects (Figure 3.1). Among them,  $a(16,16)$ ,  $a(33,16)$ ,  $a(16,33)$  and  $a(33,33)$  are “obliquely-neighboring” elements of  $p(2,2)$ .

### 3.3.6 template\_fix Construct

#### Synopsis

This construct fixes the shape and/or the distribution of an undefined template.

#### Syntax

```

031
032 [F] !$xmp template_fix [(dist-format [, dist-format]...)] ■
033 ■ template-name [(template-spec [, template-spec]...)]
034
035 [C] #pragma xmp template_fix [(dist-format [, dist-format]...)] ■
036 ■ template-name [(template-spec [, template-spec]...)]
037

```

where *template-spec* is:

```

038
039 [int-expr :] int-expr
040

```

and *dist-format* is one of:

```

041
042 *
043 block [(int-expr)]
044 cyclic [(int-expr)]
045 gblock (int-array)
046
047
048

```

#### Description

The `template_fix` construct fixes the shape and/or the distribution of the template that is initially undefined, by specifying the sizes and/or the distribution format of each dimension at runtime. Arrays aligned with an initially undefined template must be an allocatable array, in XcalableMP Fortran, or a pointer (see Section 5.5), in XcalableMP C, which cannot be allocated until the template is fixed by the `template_fix` construct. Any constructs that have such a template in their `on` clause must not be encountered until the template is fixed by the

`template_fix` construct. Any undefined template can be fixed only once by the `template_fix` construct in its scoping unit.

The meaning of the sequence of *dist-format's* is the same as that in the `distribute` directive.

### Restrictions

- When a node encounters a `template_fix` construct at runtime, the template specified by *template-name* must be undefined.
- If the sequence of *dist-format's* exists in a `template_fix` construct, it must be identical with the sequence of *dist-format's* in the `distribute` directive for the template specified by *template-name*, except for *int-array* specified in the parenthesis following `gblock`.
- Either the sequence of *dist-format's* or the sequence of *template-spec's* must be given.

### Example

```

XcalableMP Fortran
!$xmp template :: t(:)
!$xmp distribute (gblock(*)) :: t
 real , allocatable :: a(:)
5 !$xmp align (i) with t(i) :: a
 ...
 N = ...; M(...) = ...
 ...
10 !$xmp template_fix(gblock(M)) t(N)
 ...
 allocate (a(N))

```

Since the shape is `(:)` and the distribution format is `gblock(*)`, the template `t` is initially undefined. The allocatable array `a` is aligned with `t`. After the size `N` and the mapping array `M` is defined, `t` is fixed by the `template_fix` construct and `a` is allocated.

## 3.4 Work Mapping Construct

### 3.4.1 task Construct

#### Synopsis

The `task` construct defines a task that is executed by a specified node set.

#### Syntax

- ```

[F] !$xmp task on {nodes-ref | template-ref}
    structured-block
    !$xmp end task

[C] #pragma xmp task on {nodes-ref | template-ref}
    structured-block

```

Description

When a node encounters a `task` construct at runtime, it executes the associated block (called a *task*) if it is included by the node set specified by the `on` clause; otherwise it skips executing the block.

Unless a `task` construct is surrounded by a `tasks` construct, *nodes-ref* or *template-ref* in the `on` clause is evaluated by the executing node set at the entry of the task; otherwise *nodes-ref* and *template-ref* of the `task` construct are evaluated by the executing node set at the entry of the immediately surrounding `tasks` construct. The current executing node set is set to that specified by the `on` clause at the entry of the `task` construct and rewound to the last one at the exit.

Restrictions

- The node set specified by *nodes-ref* or *template-ref* in the `on` clause must be a subset of the parent node set.

Example

Example 1 Copies of variables `a` and `b` are replicated on nodes `nd(1)` through `nd(8)`. A task defined by the `task` construct is executed only on `nd(1)` and defines the copies of `a` and `b` on a node `nd(1)`. The copies on nodes `nd(2)` through `nd(8)` are not defined.

	XcalableMP Fortran	XcalableMP C	
036	!\$xmp nodes nd(8)	#pragma xmp nodes nd(8)	
037	!\$xmp template t(100)	#pragma xmp template t(100)	
038	!\$xmp distribute t(block) onto nd	#pragma xmp distribute t(block) onto nd	
039			
040			
041	real a, b;	float a, b;	5
042			
043	!\$xmp task on nd(1)	#pragma xmp task on nd(1)	
044	read(*,*) a	{	
045	b = a*1.e-6	scanf ("%f", &a);	
046		b = a*1.e-6;	
047	!\$xmp end task	}	10

Example 2 According to the `on` clause with a template reference, an assignment statement in the `task` construct is executed by the owner of the array element `a(:,j)` or `a[j][:]`.

	XcalableMP Fortran	XcalableMP C	
	!\$xmp nodes nd(8)	#pragma xmp nodes nd(8)	001
	!\$xmp template t(100)	#pragma xmp template t(100)	002
	!\$xmp distribute t(block) onto nd	#pragma xmp distribute t(block) onto nd	003
			004
5	integer i,j	int i,j;	005
	real a(200,100)	float a[100][200];	006
	!\$xmp align a(*,j) with t(j)	#pragma align a[j][*] with t(j+1)	007
			008
	i = ...	i = ...;	009
			010
10	j = ...	j = ...;	011
			012
	!\$xmp task on t(j)	#pragma xmp task on t(j+1)	013
	a(i,j) = 1.0	a[j][i] = 1.0;	014
	!\$xmp end task	}	015
			016
			017
			018
			019
			020
			021
			022
			023
			024
			025
			026
			027
			028
			029
			030
			031
			032
			033
			034
			035
			036
			037
			038
			039
			040
			041
			042
			043
			044
			045
			046
			047
			048
			049
			050
			051
			052
			053
			054
			055
			056
			057

3.4.2 tasks Construct

Synopsis

The `tasks` construct is used to instruct the executing nodes to execute the multiple tasks it surrounds in arbitrary order.

Syntax

```
[F] !$xmp tasks
    task-construct
    ...
    !$xmp end tasks

[C] #pragma xmp tasks
    {
        task-construct
        ...
    }
```

Description

`task` constructs surrounded by a `tasks` construct are executed in arbitrary order without implicit synchronization at the entry of each task. As a result, if there is no overlap between the executing node sets of the adjacent tasks, they can be executed in parallel.

nodes-ref or *template-ref* of each task immediately surrounded by a `tasks` construct is evaluated by the executing node set at the entry of the `tasks` construct.

No implicit synchronization is performed at the entry and exit of the `tasks` construct.

Example

Example 1 Three instances of subroutine `task1` are concurrently executed by node sets `p(1:500)`, `p(501:800)` and `p(801:1000)`, respectively.

```

001      XcalableMP Fortran
002      subroutine caller
003      !$xmp nodes p(1000)
004      !$xmp template tp(100)
005      !$xmp distribute t(block) onto p
006      5      real a(100,100)
007      !$xmp align a(*,k) with t(k)
008      ...
009      !$xmp tasks
010      !$xmp task on p(1:500)
011      10      call task1(a)
012      !$xmp end task
013      !$xmp task on p(501:800)
014      call task1(a)
015      !$xmp end task
016      15      !$xmp task on p(801:1000)
017      call task1(a)
018      !$xmp end task
019      !$xmp end tasks
020      ...
021      end subroutine
022
023
024
025
026
027
028
029
030
031
032      XcalableMP Fortran
033      subroutine task1(a)
034      ...
035      !$xmp nodes q(*)=*
036
037      5      !$xmp nodes p(1000)
038      !$xmp distribute t(block) onto p
039      real a(100,100)
040      !$xmp align a(*,k) with t(k)
041      ...
042      10      end subroutine
043
044
045
046
047
048
049
050
051
052
053
054
055
056
057

```

Example 2 The first node $p(1)$ executes the first and the second tasks, the final node $p(8)$ the second and the third tasks, and the other nodes $p(2)$ through $p(7)$ only the second task.

```

032      XcalableMP Fortran
033      !$xmp nodes p(8)
034      !$xmp template t(100)
035      !$xmp distribute t(block) onto p
036      real a(100)
037      5      !$xmp align a(i) with t(i)
038      ...
039      !$xmp tasks
040
041      10      !$xmp task on t(1)
042      a(1) = 0.0
043      !$xmp end task
044
045      15      !$xmp task on t(2:99)
046      !$xmp loop on t(i)
047      do i=2,99
048      a(i) = foo(i)
049      enddo
050      !$xmp end task
051
052      20      !$xmp task on t(100)
053      a(100) = 0.0
054      !$xmp end task
055
056
057

```

```
!$xmp end tasks
```

3.4.3 loop Construct

Synopsis

The `loop` construct specifies that each iteration of the following loop is executed by a node set specified by the `on` clause, so that the iterations are distributed among nodes and executed in parallel.

Syntax

```
[F] !$xmp loop [ ( loop-index [, loop-index]... ) ] ■
           ■ on { nodes-ref | template-ref } [ reduction-clause ]...
           do-loops
```

```
[C] #pragma xmp loop [ ( loop-index [, loop-index]... ) ] ■
           ■ on { nodes-ref | template-ref } [ reduction-clause ]...
           for-loops
```

where *reduction-clause* is:

```
reduction( reduction-kind : reduction-spec [, reduction-spec ]... )
```

reduction-kind is one of:

001
002
003
004
005
006
007
008
009
010
011
012
013
014
015
016
017
018
019
020
021
022
023
024
025
026
027
028
029
030
031
032
033
034
035
036
037
038
039
040
041
042
043
044
045
046
047
048
049
050
051
052
053
054
055
056
057

```

001      [F] +
002          *
003          -
004          .and.
005          .or.
006          .eqv.
007          .neqv.
008          max
009          min
010          iand
011          ior
012          ieor
013          firstmax
014          firstmin
015          lastmax
016          lastmin
017
018
019
020      [C] +
021          *
022          -
023          &
024          |
025          ^
026          &&
027          ||
028          max
029          min
030          firstmax
031          firstmin
032          lastmax
033          lastmin
034
035

```

and *reduction-spec* is:

$$\textit{reduction-variable} [/ \textit{location-variable} [, \textit{location-variable}] \dots /]$$

Description

A `loop` directive is associated with a loop nest consisting of one or more tightly-nested loops that follow the directive and distribute the execution of their iterations onto the node set specified by the `on` clause.

The sequence of *loop-index's* in parenthesis denotes an index of an iteration of the loop nests. If a control variable of a loop does not appear in the sequence, it is assumed that each possible value of it is specified in the sequence. The sequence can be considered to denote a set of indices of iterations. When the sequence is omitted, it is assumed that the control variables of all the loops in the associated loop nests are specified.

When a *template-ref* is specified in the `on` clause, the associated loop is distributed so that the iteration (set) indexed by the the sequence of *loop-index's* is executed by the node onto which a template element specified by the *template-ref* is distributed.

When a *nodes-ref* is specified in the `on` clause, the associated loop is distributed so that the iteration (set) indexed by the the sequence of *loop-index's* is executed by a node specified by the

nodes-ref.

In addition, the executing node set is updated to the node set specified by the `on` clause at the beginning of every iteration and restored to the last one at the end of it.

When a *reduction-clause* is specified, a reduction operation of the kind specified by *reduction-kind* for a variable specified by *reduction-variable* is executed just after the execution of the loop nest.

The reduction operation executed, except in cases with *reduction-kind* of `FIRSTMAX`, `FIRSTMIN`, `LASTMAX`, or `LASTMIN`, is equivalent to the `reduction` construct with the same *reduction-kind* and *reduction-variable*, and an `on` clause obtained from that of the `loop` directive by replacing:

- “:” in the *nodes-ref* or the *template-ref* with “*”, and
- *loop-index* in the *nodes-ref* or the *template-ref* with a triplet representing the range of its value.

Therefore, for example, the two codes below are equivalent.

<pre style="margin: 0;"> XcalableMP Fortran !\$xmp loop (j) on t(:,j) !\$xmp+ reduction(op:s) do j = js, je ... do i = 1, N s = s op a(i,j) end do ... end do </pre>	<pre style="margin: 0;"> XcalableMP Fortran // Initialize s_tmp to the identity // element of the op operator s_tmp = ... !\$xmp loop (j) on t(:,j) do j = js, je ... do i = 1, N s_tmp = s_tmp op a(i,j) end do ... end do !\$xmp reduction(op:s_tmp) !\$xmp+ on t(*,js:je) s = s op s_tmp </pre>
--	---

Particularly for the reduction kinds of `FIRSTMAX`, `FIRSTMIN`, `LASTMAX` and `LASTMIN`, in addition to a corresponding `MAX` or `MIN` reduction operation, the *location-variable*'s are set after executing the loop construct as follows:

- For `FIRSTMAX` and `FIRSTMIN`, they are set to their values at the end of the *first* iteration in which the *reduction-variable* takes the value of the reduction result, where *first* means first in the sequential order in which iterations of the associated loop nest were executed without parallelization.
- For `LASTMAX` and `LASTMIN`, they are set to their values at the end of the *last* iteration in which the *reduction-variable* takes the value of the reduction result, where *last* means last in the sequential order in which iterations of the associated loop nest were executed without parallelization.

Restrictions

- *loop-index* must be a control variable of a loop in the associated loop nest.

- A control variable of a loop can appear as *loop-index* at most once.
- The node set specified by *nodes-ref* or *template-ref* in the **on** clause must be a subset of the parent node set.
- The template specified by *template-ref* must be fixed before the loop construct is executed.
- The **loop** construct is global, which means that it must be executed by all of the executing nodes, and each local variable referenced in the directive must have the same value among all of them, and the lower bound, upper bound and step of the associated loop must have the same value among all of them.
- *reduction-spec* must have one or more *location-variable*'s if and only if *reduction-kind* is either FIRSTMAX, FIRSTMIN, LASTMAX, or LASTMIN.

Examples

Example 1

```

XcalableMP Fortran
!$xmp distribute t(block) onto p
!$xmp align (i) with t(i) :: a, b
...
!$xmp loop (i) on t(i)
5 do i = 1, N
    a(i) = 1.0
    b(i) = a(i)
end do

```

The **loop** construct determines the node that executes each of the iterations, according to the distribution of template *t*, and distributes the execution. This example is syntactically equivalent to the one shown below, but will be faster because iterations to be executed by each node can be determined before executing the loop.

```

XcalableMP Fortran
!$xmp distribute t(block) onto p
!$xmp align (i) with t(i) :: a, b
...
5 do i = 1, N
!$xmp task on t(i)
    a(i) = 1.0
    b(i) = a(i)
!$xmp end task
end do

```

Example 2

```

XcalableMP Fortran
!$xmp distribute t(*,block) onto p
!$xmp align (i,j) with t(i,j) :: a, b
...
!$xmp loop (i,j) on t(i,j)
5 do j = 1, M
    do i = 1, N
        a(i,j) = 1.0
    end do
end do

```

```

        b(i,j) = a(i,j)
      end do
10    end do

```

Since the first dimension of template `t` is not distributed, only the `j` loop, which is aligned with the second dimension of `t`, is distributed. This example is syntactically equivalent to the `task` construct shown below.

```

XcalableMP Fortran
!$xmp distribute t(*,block) onto p
!$xmp align (*,j) with t(*,j) :: a, b
...
5  do j = 1, M
!$xmp task on t(*,j)
      do i = 1, N
          a(i,j) = 1.0
          b(i,j) = a(i,j)
      end do
10 !$xmp end task
    end do

```

Example 3

```

XcalableMP Fortran
!$xmp distribute t(block,block) onto p
!$xmp align (i,j) with t(i,j) :: a, b
...
5  !$xmp loop (i,j) on t(i,j)
    do j = 1, M
        do i = 1, N
            a(i,j) = 1.0
            b(i,j) = a(i,j)
        end do
10 end do

```

The distribution of loops in the nested loop can be specified using the sequence of *loop-index*'s in one loop construct. This example is equivalent to the loop shown below, but will run faster because the iterations to be executed by each node can be determined outside of the nested loop. Note that the node set specified by the inner `on` clause is a subset of that specified by the outer one.

```

XcalableMP Fortran
!$xmp distribute t(block,block) onto p
!$xmp align (i,j) with t(i,j) :: a, b
...
5  !$xmp loop (j) on t(:,j)
    do j = 1, M
!$xmp loop (i) on t(i,j)
        do i = 1, N
            a(i,j) = 1.0
            b(i,j) = a(i,j)
10        end do
    end do

```

Example 4

```

001
002
003
004
005
006
007
008
009
010
011
012
013
014
015
016
017
018
019
020
021
022
023
024
025
026
027
028
029
030
031
032
033
034
035
036
037
038
039
040
041
042
043
044
045
046
047
048
049
050
051
052
053
054
055
056
057

```

XcalableMP Fortran

```

!$xmp nodes p(10,3)
...
!$xmp loop on p(:,i)
  do i = 1, 3
    call subtask ( i )
  end do

```

Three node sets $p(:,1)$, $p(:,2)$ and $p(:,3)$ are created as the executing node sets, and each of them executes iteration 1, 2 and 3 of the associated loop, respectively. This example is equivalent to the loop containing `task` constructs (below left) or static `tasks/task` constructs (below right).

XcalableMP Fortran

```

!$xmp nodes p(10,3)
...
  do i = 1, 3
!$xmp task on p(:,i)
    call subtask ( i )
!$xmp end task
  end do

```

XcalableMP Fortran

```

!$xmp nodes p(10,3)
...
!$xmp tasks
!$xmp task on p(:,1)
  call subtask ( 1 )
!$xmp end task
!$xmp task on p(:,2)
  call subtask ( 2 )
!$xmp end task
!$xmp task on p(:,3)
  call subtask ( 3 )
!$xmp end task
!$xmp end tasks

```

Example 5

```

001
002
003
004
005
006
007
008
009
010
011
012
013
014
015
016
017
018
019
020
021
022
023
024
025
026
027
028
029
030
031
032
033
034
035
036
037
038
039
040
041
042
043
044
045
046
047
048
049
050
051
052
053
054
055
056
057

```

XcalableMP Fortran

```

...
  lb(1) = 1
  iub(1) = 10
  lb(2) = 11
  iub(2) = 25
  lb(3) = 26
  iub(3) = 50
!$xmp loop (i) on p(lb(i):iub(i))
  do i = 1, 3
    call subtask ( i )
  end do

```

The executing node sets of different sizes are created by $p(lb(i):iub(i))$ with different values of i for unbalanced workloads. This example is equivalent to the loop containing `task` constructs (below left) or static `tasks/task` constructs (below right).

<pre style="margin: 0;"> XcalableMP Fortran do i = 1, 3 !\$xmp task on p(lb(i):iub(i)) call subtask (i) !\$xmp end task end do ... </pre>	<pre style="margin: 0;"> XcalableMP Fortran !\$xmp tasks !\$xmp task on p(1:10) call subtask (1) !\$xmp end task !\$xmp task on p(11:25) call subtask (2) !\$xmp end task !\$xmp task on p(25:50) call subtask (3) !\$xmp end task !\$xmp end tasks </pre>	001 002 003 004 005 006 007 008 009 010 011 012 013 014 015 016 017 018 019 020 021 022 023 024 025 026 027 028 029 030 031 032 033 034 035 036 037 038 039 040 041 042 043 044 045 046 047 048 049 050 051 052 053 054 055 056 057
---	--	---

Example 6

<pre style="margin: 0;"> XcalableMP Fortran ... s = 0.0 !\$xmp loop (i) on t(i) reduction(+:s) do i = 1, N s = s + a(i) end do </pre>	019 020 021 022 023 024 025 026 027 028 029 030 031 032 033 034 035 036 037 038 039 040 041 042 043 044 045 046 047 048 049 050 051 052 053 054 055 056 057
---	---

This loop computes the sum of $a(i)$ into the variable s on each node. Note that only the partial sum is computed on s without the reduction clause. This example is equivalent to the code given below.

<pre style="margin: 0;"> XcalableMP Fortran ... s = 0.0 !\$xmp loop (i) on t(i) do i = 1, N s = s + a(i) end do !\$xmp reduction(+:s) on t(1:N) </pre>	032 033 034 035 036 037 038 039 040 041 042 043 044 045 046 047 048 049 050 051 052 053 054 055 056 057
--	--

Example 7

<pre style="margin: 0;"> XcalableMP Fortran ... amax = -1.0e30 ip = -1 jp = -1 !\$xmp loop (i,j) on t(i,j) reduction(firstmax:amax/ip,jp/) do j = 1, M do i = 1, N if(1(i,j) .gt. amx) then amx = a(i,j) ip = i jp = j end if </pre>	044 045 046 047 048 049 050 051 052 053 054 055 056 057
--	--

```

001         end do
002     end do

```

This loop computes the maximum value of $a(i, j)$ and stores it into the variable `amax` in each node. In addition, the first indices for the maximum element of `a` are obtained in `ip` and `jp` after executing the loops. Note that this example cannot be written with the `reduction` construct.

3.4.4 array Construct

Synopsis

The `array` construct divides the work of an array assignment among nodes.

Syntax

[F] `!$xmp array on template-ref
array-assignment-statement`

[C] `#pragma xmp array on template-ref
array-assignment-statement`

Description

The array assignment is an alternative to a loop that performs an assignment to each element of an array. This directive specifies parallel execution of an array assignment, where each sub-assignment and sub-operation of an element is executed by a node determined by the `on` clause.

Note that array assignments can be used also in XcalableMP C, which is one of the language extensions introduced by XcalableMP (see Section 5.2).

Restrictions

- The node set specified by *template-ref* in the `on` clause must be a subset of the parent node set.
- The template section specified by *template-ref* must have the same shape with the associated array assignment.
- The `array` construct is global and must be executed by all of the executing nodes, and each variable appearing in the construct must have the same value among all of them.

Examples

Example 1

```

048                                     XcalableMP Fortran
049     !$xmp distribute t(block) onto p
050     !$xmp align (i) with t(i) :: a
051         ...
052     !$xmp array on t(1:N)
053     a(1:N) = 1.0

```

This example is equivalent to the code shown below.

```

XcalableMP Fortran
!$xmp distribute t(block) onto p
!$xmp align (i) with t(i) :: a
...
!$xmp loop on t(1:N)
5 do i = 1, N
    a(i) = 1.0
end do

```

Example 2

```

XcalableMP Fortran
!$xmp template t(100,20)
!$xmp distribute t(block,block) onto p
dimension a(100,20), b(100,20)
!$xmp align (i,j) with t(i,j) :: a, b
5 ...
!$xmp array on t
a = b + 2.0

```

This example is equivalent to the code shown below.

```

XcalableMP Fortran
!$xmp template t(100,20)
!$xmp distribute t(block,block) onto p
dimension a(100,20), b(100,20)
!$xmp align (i,j) with t(i,j) :: a, b
5 ...
!$xmp loop (i,j) on t(i,j)
do j = 1, 20
do i = 1, 100
a(i,j) = b(i,j) + 2.0
10 end do
end do

```

3.5 Global-view Communication and Synchronization Constructs

3.5.1 reflect Construct

Synopsis

The `reflect` construct assigns the value of a reflection source to the corresponding shadow object.

Syntax

- ```

[F] !$xmp reflect (array-name [, array-name]...) ■
 ■ [width (reflect-width [, reflect-width]...)] [async (async-id)]
[C] #pragma xmp reflect (array-name [, array-name]...) ■
 ■ [width (reflect-width [, reflect-width]...)] [async (async-id)]

```

where *reflect-width* must be one of:

```

001 [/periodic/] int-expr
002 [/periodic/] int-expr : int-expr
003

```

### 004 Description

005  
006 The **reflect** construct updates each of the shadow object of the array specified by *array-name*  
007 with the value of its corresponding reflection source. Note that the shadow objects corresponding  
008 to “obliquely-neighboring” elements can be also updated with this construct.

009 When the **width** clause is specified and of the form “*int-expr* : *int-expr*” in a dimension, the  
010 shadow area of the width specified by the first *int-expr* at the upper bound and that specified  
011 by the second one at the lower bound in the dimension are updated. When the **width** clause  
012 is specified and of the form *int-expr*, the shadow areas of the same width specified at both the  
013 upper and lower bounds in the dimension are updated. When the **width** clause is omitted, whole  
014 shadow area of the array is updated.

015  
016 Particularly when the **/periodic/** modifier is specified in *reflect-width*, the update of the  
017 shadow object in the dimension is “periodic,” which means that the shadow object at the global  
018 lower (upper) bound is treated as if corresponding to the data object of the global upper (lower)  
019 bound and updated with that value by the **reflect** construct.

020  
021 When the **async** clause is specified, the statements following this construct may be executed  
022 before the operation is complete.

### 024 Restrictions

- 025  
026 • The arrays specified by the sequence of *array-name*’s must be mapped onto the executing  
027 node set.
- 028  
029 • The reflect width of each dimension specified by *reflect-width* must not exceed the shadow  
030 width of the arrays.
- 031  
032 • The **reflect** construct is global, which means that it must be executed by all nodes in  
033 the current executing node set, and each local variable referenced in the construct must  
034 have the same value among all of them.
- 035  
036 • *async-id* must be an expression of type default integer, in XcalableMP Fortran, or type  
037 **int**, in XcalableMP C.

### 039 Example

```

040 _____ XcalableMP Fortran _____
041 !$xmp nodes p(4)
042 !$xmp template t(100)
043 !$xmp distribute t(block) onto p:: t
044
045 5 real a(100)
046 !$xmp align a(i) with t(i)
047 !$xmp shdow a(1)
048
049
050 ...
051 10 !$xmp reflect (a) width (/periodic/1)
052

```

053  
054 The **shadow** directive allocates “periodic” shadow areas of the array **a**. The **reflect** con-  
055 struct updates “periodically” the shadow area of **a** (Figure 3.2). A periodic shadow at the lower  
056 bound on the node **p(1)** is updated with the value of **a(100)** and that at the upper bound on  
057 **p(4)** with the value of **a(1)**.

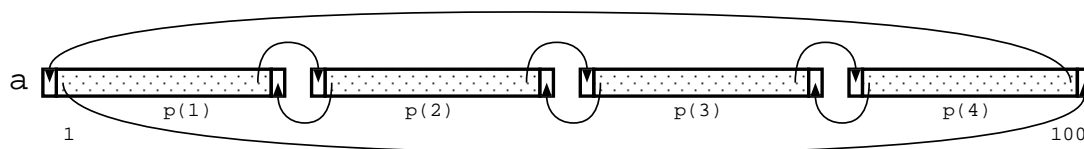

Figure 3.2: Example of Periodic Shadow Reflection

### 3.5.2 gmove Construct

#### Synopsis

The `gmove` construct allows an assignment statement, which may cause communication, to be executed possibly in parallel by the executing nodes.

#### Syntax

```
[F] !$xmp gmove [in | out] [async (async-id)]
[C] #pragma xmp gmove [in | out] [async (async-id)]
```

#### Description

This construct copies the value of the right-hand side (rhs) variable into the left-hand side (lhs) of the associated assignment statement, which may require communication between the executing nodes. Such communication is detected, scheduled, and performed by the XcalableMP runtime system.

There are three operating modes of the `gmove` construct:

- **collective mode**

When neither the `in` nor the `out` clause is specified, the copy operation is performed collectively and cause an implicit synchronization after it among the executing nodes.

If the `async` clause is not specified, then the construct is “synchronous” and it is guaranteed that the lhs data can be read and overwritten, the rhs data can be overwritten, and all of the operations of the construct on the executing nodes are completed when returning from the construct; otherwise, the construct is “asynchronous” and it is not guaranteed that until returning from the associating `wait_async` construct (Section 3.5.6).

- **in mode**

When the `in` clause is specified, the rhs data of the assignment, whole or parts of which may reside outside the executing node set, can be transferred from its owner nodes to the executing nodes by this construct.

If the `async` clause is not specified, then the construct is “synchronous” and it is guaranteed that the lhs data can be read and overwritten and all of the operations of the construct on the owner nodes of the rhs and the executing nodes are completed when returning from the construct; otherwise, the construct is “asynchronous” and it is not guaranteed that until returning from the associating `wait_async` construct (Section 3.5.6).

- **out mode**

When the `out` clause is specified, the lhs data of the assignment, whole or parts of which may reside outside the executing node set, can be transferred from the executing nodes to its owner nodes by this construct.

001  
002  
003  
004  
005  
006  
007  
008  
009  
010  
011  
012  
013  
014  
015  
016  
017  
018  
019  
020  
021  
022  
023  
024  
025  
026  
027  
028  
029  
030  
031  
032  
033  
034  
035  
036  
037  
038  
039  
040  
041  
042  
043  
044  
045  
046  
047  
048  
049  
050  
051  
052  
053  
054  
055  
056  
057

If the `async` clause is not specified, then the construct is “synchronous” and it is guaranteed that the rhs data can be overwritten and all of the operations of the construct on the owner nodes of the lhs and the executing nodes are completed when returning from the construct; otherwise, the construct is “asynchronous” and it is not guaranteed that until returning from the associating `wait_async` construct (Section 3.5.6).

When the `async` clause is specified, the statements following this construct may be executed before the operation is complete.

### Restrictions

- The `gmove` construct must be followed by (i.e. associated with) a simple assignment statement that contains neither arithmetic operations nor function calls.
- The `gmove` construct is global, which means that it must be executed by all nodes in the current executing node set, and each local variable referenced in the construct must have the same value among all of them.
- If the `gmove` construct is in *collective* mode, then all elements of the distributed arrays appearing in both the lhs and the rhs of the associated assignment statement must reside in the executing node set.
- If the `gmove` construct is in *in* mode, then all elements of the distributed array appearing in the lhs of the associated assignment statement must reside in the executing node set.
- If the `gmove` construct is in *out* mode, then all elements of the distributed array appearing in the rhs of the associated assignment statement must reside in the executing node set.
- *async-id* must be an expression of type default integer, in XcalableMP Fortran, or type `int`, in XcalableMP C.

### Examples

**Example 1: Array assignment** If both the lhs and the rhs are distributed arrays, then the copy operation is performed by all-to-all communication. If the lhs is a replicated array, this copy is performed by multi-cast communication. If the rhs is a replicated array, then no communication is required.

| XcalableMP Fortran                                | XcalableMP C                                             |
|---------------------------------------------------|----------------------------------------------------------|
| <pre>!\$xmp gmove   a(:,1:N) = b(:,3,0:N-1)</pre> | <pre>#pragma xmp gmove   a[1:N][:] = b[0:N][3][:];</pre> |

**Example 2: Scalar assignment to an array** When the rhs is an element of a distributed array, the copy is performed by broadcast communication from the owner of the element. If the rhs is a replicated array, then no communication is required.

| XcalableMP Fortran                        | XcalableMP C                                    |
|-------------------------------------------|-------------------------------------------------|
| <pre>!\$xmp gmove   a(:,1:N) = c(k)</pre> | <pre>#pragma xmp gmove   a[1:N][:] = c[k]</pre> |

**Example 3: in mode assignment** Since `b(3)` referenced in the rhs of the `gmove` construct does not reside in the executing node set (`p(1:2)`), the construct is executed in in mode. Thus, `b(3)` is transferred from its owner node `p(3)` to the executing node set.

It is not guaranteed until `p(1:2)` returns from the construct that any node can read and overwrite `a(1:2)` and any relevant operations on `p(1:2)` and `p(3)` are completed.

```

 XcalableMP Fortran
!$xmp nodes p(4)
!$xmp template t(4)
!$xmp distribute t(block) onto p
5 real a(4), b(4)
!$xmp align (i) with t(i) : a, b
 ...
!$xmp task on p(1:2)
 ...
10 !$xmp gmove in
 a(1:2) = b(2:3)
 ...
!$xmp end task
```

### 3.5.3 barrier Construct

#### Synopsis

The barrier construct specifies an explicit barrier at the point at which the construct appears.

#### Syntax

```
[F] !$xmp barrier [on nodes-ref | template-ref]
[C] #pragma xmp barrier [on nodes-ref | template-ref]
```

#### Description

The barrier operation is performed among the node set specified by the `on` clause. If no `on` clause is specified, then it is assumed that the current executing node set is specified in it.

Note that an `on` clause may represent multiple node sets. In such a case, a barrier operation is performed in each node set.

#### Restriction

- The node set specified by the `on` clause must be a subset of the executing node set.

### 3.5.4 reduction Construct

#### Synopsis

The reduction construct performs a reduction operation among nodes.

## Syntax

```
001 [F] !$xmp reduction (reduction-kind : variable [, variable]...) █
002
003 █ [on node-ref | template-ref] [async (async-id)]
```

where *reduction-kind* is one of:

```
007 +
008 *
009 -
010 .and.
011 .or.
012 .eqv.
013 .neqv.
014 max
015 min
016 iand
017 ior
018 ieor
```

```
021
022 [C] #pragma xmp reduction (reduction-kind : variable [, variable]...) █
023 █ [on node-ref | template-ref] [async (async-id)]
```

where *reduction-kind* is one of:

```
026 +
027 *
028 -
029 &
030 |
031 ^
032 &&
033 ||
034 max
035 min
```

## Description

The **reduction** construct performs a type of reduction operation specified by *reduction-kind* for the specified local variables among the node set specified by the **on** clause and sets the reduction results to the variables on each of the nodes. Note that some of the reduction operation (FIRSTMAX, FIRSTMIN, LASTMAX, and LASTMIN) that could be specified in the **reduction** clause of the loop directive cannot be specified in the **reduction** construct, because their semantics are not defined in it. The variable specified by *variable*, which is the target of the reduction operation, is referred to as the “reduction variable.” After the reduction operation, the value of a reduction variable becomes the same in every node that performs the operation.

The reduction result is computed by combining the reduction variables on all of the nodes using the reduction operator. The ordering of this reduction is implementation-dependent.

When the **async** clause is specified, the statements following this construct may be executed before the operation is complete.

When *template-ref* is specified in the **on** clause, the operation is performed in a node set that consists of nodes onto which the specified template section is distributed. Therefore, before the **reduction** construct is executed, the referenced template must be fixed. When *nodes-ref* is

specified in the `on` clause, the operation is performed in the specified node set. When the `on` clause is omitted, the operation is performed in the executing node set.

Note that an `on` clause may represent multiple node sets. In such a case, a reduction operation is performed in each node set.

### Restrictions

- The variables specified by the sequence of *variable*'s must either not be aligned or be replicated among nodes of the node set specified by the `on` clause.
- The `reduction` construct is global, which means that it must be executed by all nodes in the current executing node set, and each local variable referenced in the construct must have the same value among all of them.
- *async-id* must be an expression of type default integer, in XcalableMP Fortran, or type `int`, in XcalableMP C.
- The node set specified by the `on` clause must be a subset of the executing node set.

### Examples

#### Example 1

```

_____ XcalableMP Fortran _____
!$xmp reduction(+:s)
!$xmp reduction(max:aa) on t(*,:)
!$xmp reduction(min:bb) on p(10:30)

```

In the first line, the reduction operation calculates the sum of the scalar variable `s` in the executing node set and the result is stored in the variable in each node.

The reduction operation in the second line computes the maximum value of the variable `aa` in each node set onto which each of the template section specified by `t(*, :)` is distributed.

In the third line, the minimum value of the variable `bb` in the node set specified by `p(10:30)` is calculated. This example is equivalent to the following code using the `task` construct.

```

_____ XcalableMP Fortran _____
!$xmp task on p(10:30)
!$xmp reduction(min:bb)
!$xmp end task

```

#### Example 2

```

_____ XcalableMP Fortran _____
 dimension a(n,n), p(n), w(n)
!$xmp align a(i,j) with t(i,j)
!$xmp align p(i) with t(i,*)
!$xmp align w(j) with t(*,j)
5 ...
!$xmp loop (j) on t(:,j)
 do j = 1, n
 sum = 0
!$xmp loop (i) on t(i,j) reduction(+:sum)
10 do i = 1, n
 sum = sum + a(i,j) * p(i)

```



```

001 end do
002 w(j) = sum
003 end do
004
005
006
007
008

```

This code computes the matrix vector product, where a **reduction** clause is specified for the loop construct of the inner loop. This is equivalent to the following code snippet.

```

009 XcalableMP Fortran
010 !$xmp loop (j) on t(:,j)
011 do j = 1, n
012 sum = 0
013 !$xmp loop (i) on t(i,j)
014 5 do i = 1, n
015 sum = sum + a(i,j) * p(i)
016 end do
017 !$xmp reduction(+:sum) on t(1:n,j)
018 w(j) = sum
019 10 end do
020
021
022
023
024
025
026
027
028
029

```

In these cases, the reduction operation on the scalar variable **sum** is performed for every iteration in the outer loop, which may cause a large overhead. The **reduction** clause cannot be specified for the loop construct of the outer loop to reduce this overhead, because the node set where the reduction operation specified by a **reduction** clause of a loop construct is performed is determined from its **on** clause (see 3.4.3) and the **on** clause of the outer loop construct is different from that of the inner one. However, this code can be modified with the **reduction** construct as follows:

```

030 XcalableMP Fortran
031 dimension a(n,n), p(n), w(n)
032 !$xmp align a(i,j) with t(i,j)
033 !$xmp align p(i) with t(i,*)
034 !$xmp align w(j) with t(*,j)
035 ...
036 5 !$xmp loop (j) on t(:,j)
037 do j = 1, n
038 sum = 0
039 !$xmp loop (i) on t(i,j)
040 10 do i = 1, n
041 sum = sum + a(i,j) * p(i)
042 end do
043 w(j) = sum
044 end do
045 15 !$xmp reduction(+:w) on t(1:n,*)
046
047
048
049
050
051
052
053
054
055
056
057

```

This code performs a reduction operation on the array **w** only once, which may result in faster operation.

### 3.5.5 bcast Construct

#### Synopsis

The **bcast** construct performs broadcast communication from a specified node.

**Syntax**

```
[F] !$xmp bcast (variable [, variable]...) [from nodes-ref | template-ref]
 ■ [on nodes-ref] | template-ref [async (async-id)]
[C] #pragma xmp bcast (variable [, variable]...) [from nodes-ref | template-ref]
 ■ [on nodes-ref | template-ref] [async (async-id)]
```

**Description**

The values of the variables specified by the sequence of *variable*'s (called *broadcast variables*) are broadcasted from the node specified by the **from** clause (called the *source node*) to each of the nodes in the node set specified by the **on** clause. After executing this construct, the values of the broadcast variables become the same as those in the source node. If the **from** clause is omitted, then the *first* node, that is, the leading one in Fortran's array element order, of the node set specified by the **on** clause is assumed to be a source node. If the **on** clause is omitted, then it is assumed that the current executing node set is specified in it.

When the **async** clause is specified, the statements following this construct may be executed before the operation is complete.

**Restrictions**

- The variables specified by the sequence of *variable*'s must either not be aligned or be replicated among nodes of the node set specified by the **on** clause.
- The **bcast** construct is global, which means that it must be executed by all nodes in the current executing node set, and each local variable referenced in the construct must have the same value among all of them.
- *async-id* must be an expression of type default integer, in XcalableMP Fortran, or type **int**, in XcalableMP C.
- The node set specified by the **on** clause must be a subset of the executing node set.
- The source node specified by the **from** clause must belong to the node set specified by the **on** clause.
- The source node specified by the **from** clause must be one node.

**3.5.6 wait\_async Construct****Synopsis**

The **wait\_async** construct guarantees asynchronous communications specified by *async-id* are complete.

**Syntax**

```
[F] !$xmp wait_async (async-id [, async-id]...) [on nodes-ref | template-ref]
[C] #pragma xmp wait_async (async-id [, async-id]...) [on nodes-ref | template-ref]
```

**Description**

The **wait\_async** construct blocks and therefore statements following it are not executed until all of the asynchronous communications that are specified by *async-id*'s and issued on the node set specified by the **on** clause are complete.

## Restrictions

- *async-id* must be an expression of type default integer, in XcalableMP Fortran, or type `int`, in XcalableMP C.
- *async-id* must be associated with an asynchronous communication by the `async` clause of a communication construct.
- The `wait_async` construct is global, which means that it must be executed by all nodes in the current executing node set, and each local variable referenced in the construct must have the same value among all of them.
- The node set specified by the `on` clause must be the same as those of the global constructs that initiate the asynchronous communications specified by *async-id*.

### 3.5.7 `async` Clause

#### Synopsis

The `async` clause of the `reflect`, `gmove`, `reduction` and `bcast` constructs allows the corresponding communication to be performed asynchronously.

#### Description

Communication corresponding to the construct with an `async` clause is performed asynchronously, that is, initiated but not completed, and therefore statements following it may be executed before the communication is complete.

#### Example

```

_____ XcalableMP Fortran _____
!$xmp reflect (a) async(1)
 S1
!$xmp wait_async(1)
 S2

```

The `reflect` construct on the first line matches the `wait` construct on the third line because both of their *async-id* evaluate to 1. These constructs ensure that statements in `S1` can be executed before the `reflect` communication is complete and no statement in `S2` is executed until the `reflect` communication is complete.

001  
002  
003  
004  
005  
006  
007  
008  
009  
010  
011  
012  
013  
014  
015  
016  
017  
018  
019  
020  
021  
022  
023  
024  
025  
026  
027  
028  
029  
030  
031  
032  
033  
034  
035  
036  
037  
038  
039  
040  
041  
042  
043  
044  
045  
046  
047  
048  
049  
050  
051  
052  
053  
054  
055  
056  
057

## Chapter 4

# Support for the Local-view Programming

In this chapter, the coarray features in XcalableMP, which are based on that of Fortran 2008, are described. Note that they are available also in XcalableMP C. Additionally, some directives for the local-view programming are also described.

The coarray features in Fortran 2008 are extended and integrated into XcalableMP. The specifications in this chapter are designed to achieve the following purposes:

- Upward compatibility to the Fortran 2008 coarray features  
If an XcalableMP Fortran program does not contain any XMP directives, any standard-conforming Fortran 2008 program remains standard-conforming under XcalableMP. In this sense, the interpretations and extensions defined in this chapter are upward compatible with the Fortran International Standard, ISO/IEC 1539-1:2010 (Fortran 2008).
- Support for task parallelism  
XcalableMP makes it possible to construct a task parallel program by combining multiple Fortran 2008 codes, which might be developed independently, with minimum modifications.
- Integration of global-view style programming and local-view style programming  
In XcalableMP, users can use global-view style programming of XcalableMP or local-view style programming, which is typically used in MPI or Fortran 2008 programs, appropriately according to the characteristics of code in a program.
- Possibility of the support for multiple topologies of a computing system  
An XcalableMP processor may allow users to specify the correspondence between node arrays and the topologies of a computing system and exploit the full potential of a particular system.

## 4.1 Rules Determining Image Index

This section defines how the image index of an image in a set of images is determined in association with a node array and a `task` construct.

### 4.1.1 Primary Image Index

Every image has a default image index in all the images at the invocation of a program. In XcalableMP, the default image index is the primary image index and is an integer value in the range one to the number of images at the invocation of a program.

001 A primary node array corresponds to all the images at the invocation of a program, and also  
002 corresponds to all the nodes at the invocation of a program. The primary image index of an  
003 image is the (Fortran) subscript order value of the uniquely corresponding element of a primary  
004 node array.  
005

#### 006 007 **4.1.2 Image Index Determined by a task Directive**

008 Execution of a `task` directive determines that a set of nodes (and the corresponding set of  
009 images) forms an executing node set. If a name of a node array or a subobject of a node array  
010 appears in the `task` directive, the nodes and the corresponding images in the executing node set  
011 are ordered in (Fortran) array element order in the node array or the subobject of the node array.  
012 If a name of a template array or a subobject of a template array appears in the `task` directive,  
013 the nodes and the corresponding images in the executing node set are ordered in (Fortran) array  
014 element order in the corresponding subobject of the node array. The image index of an image  
015 in the determined set of images is the integer order value in the range one to the cardinality of  
016 the set of images.  
017  
018

#### 019 020 **4.1.3 Current Image Index**

021 The image index of an image in the current set of images is the current image index.  
022

023 A current executing node array corresponds to the current set of images and also the current  
024 executing node set at the evaluation of the declaration of the node array. Each image in the  
025 current set of images corresponds to the element of an executing node array whose subscript order  
026 value is the same as the current image index of the image at the evaluation of the declaration  
027 of the executing node array. In particular, when there are no `task` directive constructs that are  
028 not completed, the current image index of an image is the same as the primary image index.  
029  
030

#### 031 032 **4.1.4 Image Index Determined by a Non-primary Node Array**

033 A non-primary node array corresponds to all the images at the invocation of a program, and  
034 also corresponds to all the nodes at the invocation of a program. The correspondence between  
035 each image and each element of a non-primary node array is processor-dependent. A processor  
036 may support any means to specify the correspondence.  
037

038 The image index of an image in all the images at the invocation of a program is the subscript  
039 order value of the corresponding element of a non-primary node array if and only if the current set  
040 of images corresponds to the non-primary node whole array in which the nodes in the executing  
041 node set are ordered in (Fortran) array element order in the non-primary node whole array. The  
042 image index is a non-primary image index.  
043

044 The correspondence between the primary image index and a non-primary image index of  
045 the same image is processor-dependent. Between any two distinct non-primary node arrays, the  
046 correspondence between a non-primary image index and the other non-primary image index of  
047 the same image is processor-dependent unless they have the same shape. If two non-primary  
048 node arrays have the same shape, the corresponding elements of the node arrays correspond to  
049 the same image.  
050

#### 051 052 **4.1.5 Image Index Determined by an Equivalenced Node Array**

053 A `nodes` directive with “=*node-ref*” that is not “=\*” or “=\*\*” specifies that each element of the  
054 declared node array corresponds in (Fortran) array element order to that of the *node-ref*, which  
055 is a name of a node array or a subobject of a node array. The nodes in the declared node array  
056 and the corresponding images are ordered in (Fortran) array element order in the *node-ref*. The  
057

image index of an image in the set of images corresponding to the declared node array is the integer order value in the range one to the cardinality of the set of images.

#### 4.1.6 On-node Image Index

XcalableMP supports the `coarray` directive and the `image` directive to specify that an image index indicates the image corresponding to the element of a particular node array whose subscript order value is the same as the image index. The image index is an on-node image index for the specified node array. Since evaluation of the declaration of a node array determines a set of images corresponding to the node array, the directives specify that the set of images is the “all images” for the image indices the directives affect. In particular, the on-node image index for a primary node array is the primary image index.

## 4.2 Basic Concepts

In XcalableMP, “all images” in Fortran 2008 changes coupled with the execution of `task` constructs and means the current set of images. In particular, when an `allocate` statement is executed for which an *allocate-object* is a coarray, there is an implicit synchronization of all the images in the current set of images. On each image in the current set of images, execution of the segment following the statement is delayed until all other images in the set have executed the same statement the same number of times. When a `deallocate` statement is executed for which an *allocate-object* is a coarray, there is an implicit synchronization of all the images in the current set of images. On each image in the current set of images, execution of the segment following the statement is delayed until all other images in the set have executed the same statement the same number of times.

- When an allocatable coarray is allocated during the execution of `task` constructs, the coarray shall be subsequently deallocated before the completion of the `task` construct whose `task` directive is the most lately executed one in the `task` constructs that are not completed at the allocation.

The image index determined by an image selector indicates the current image index by default. Coarrays are visible within the range of the “all images” and accessed with the current image index by default. The image index that appears in an executable statement indicates the current image index by default.

### 4.2.1 Examples

- In the following code fragment, the value of a coarray `b` on the images 1, 2, 3, and 4, which constitute the executing node set and correspond to `node(5)`, `node(6)`, `node(7)`, and `node(8)` respectively, is defined with the value of the coarray `a` on `node(5)`.

```

XcalableMP Fortran
program xmpcoarray
!$xmp nodes node(8)=** ! A primary node array.
!$xmp task on node(5:8) ! The executing node set
 call sub ! corresponds to node(5:8).
5 !$xmp end task
end

subroutine sub
real, save :: a[*], b[*] ! The images 1, 2, 3,

```

```

10 : ! and 4 correspond to node(5:8),
002 b = a[1] ! respectively.

```

- In the following code fragment, an allocatable coarray `a` is allocated on the images 1, 2, 3, and 4, which constitute the executing node set and correspond to `node(5)`, `node(6)`, `node(7)`, and `node(8)` respectively.

```

009 XcalableMP Fortran
010 program xmpcoarray
011 !$xmp nodes node(8)=**
012 !$xmp task on node(5:8) ! The executing node set
013 call sub2 ! corresponds to node(5:8).
014 5 !$xmp end task
015 end
016
017 subroutine sub2
018 real, allocatable :: a(:)[:]
019 :
020 10 allocate(a(0:99)[*])
021
022
023
024
025
026
027
028
029
030
031
032
033
034
035
036
037
038
039
040
041
042
043
044
045
046
047
048
049
050
051
052
053
054
055
056
057

```

## Note

- The result value of `xmp_num_nodes()` is always the same as that of `NUM_IMAGES()`.
- The result value of `xmp_node_num()` is always the same as that of `THIS_IMAGE()`.
- In a `read` statement, an io-unit that is an asterisk identifies an external unit that is preconnected for sequential formatted input only on the image whose primary image index is one.

## 4.3 coarray Directive

### 4.3.1 Purpose and Form of the coarray Directive

The `coarray` directive maps coarrays onto a node array and the set of images that corresponds to the node array. An image index determined by an image selector for a coarray that appears in a `coarray` directive always indicates the on-node image index for the node array; that is, the specified image corresponds to the node whose subscript order value in the node array is the same as the image index.

A coarray appearing in a `coarray` directive is an on-node coarray of the node array that is specified in the `coarray` directive.

```
[F] !$xmp coarray on node-name :: object-name-list
```

```
[C] #pragma xmp coarray on node-name :: object-name-list
```

- An *object-name* shall be a name of a coarray declared in the same scoping unit.
- The same *object-name* shall not appear more than once in `coarray` directives in a scoping unit.

- If an *object-name* is a name of an allocatable object, the current set of images at the allocation and the deallocation of the object shall correspond to the node array specified as the *node-name* and the current image index of each image shall be the same as the subscript order value of the corresponding element of the node array.
- If an *object-name* is a name of an allocated allocatable dummy argument, the set of images onto which it is mapped shall be a subset of the set of images that has allocated most lately the corresponding argument in the chain of argument associations.
- If an *object-name* is a name of a nonallocatable dummy argument whose ultimate argument has allocatable attribute, the set of images onto which the *object-name* is mapped shall be a subset of the set of images that has allocated most lately the corresponding argument in the chain of argument associations.
- The image index determined by an image selector for an on-node coarray shall be in the range of one to the size of the node array onto which the on-node coarray is mapped.
- THIS\_IMAGE(COARRAY[,DIM]) shall be invoked by the image contained in the set of images onto which the COARRAY argument is mapped, if the COARRAY argument appears in a `coarray` directive.

#### Note

- The result value of THIS\_IMAGE(COARRAY) is the sequence of cosubscript values for the COARRAY argument that would specify the current image index of the invoking image, if the COARRAY argument does not appear in a `coarray` directive. The result value of THIS\_IMAGE(COARRAY) is the sequence of cosubscript values for the COARRAY argument that would specify the on-node image index of the invoking image for the node array onto which the COARRAY argument is mapped, if the COARRAY argument appears in a `coarray` directive.
- The result value of THIS\_IMAGE(COARRAY,DIM) is the value of cosubscript DIM in the sequence of cosubscript values for the COARRAY argument that would specify the current image index of the invoking image, if the COARRAY argument does not appear in a `coarray` directive. The result value of THIS\_IMAGE(COARRAY,DIM) is the value of cosubscript DIM in the sequence of cosubscript values for the COARRAY argument that would specify the on-node image index of the invoking image for the node array onto which the COARRAY argument is mapped, if the COARRAY argument appears in a `coarray` directive.

#### 4.3.2 An Example of the `coarray` Directive

```

XcalableMP Fortran
module global
!$xmp nodes node(8)**
 real s[*] ! The coarray s is always
!$xmp coarray on node :: s ! visible on node(1:8).
end global

program coarray
 use global
!$xmp task on node(5:8) ! The executing node set
 call sub ! consists of node(5:8).

```



```

001 !$xmp end task
002 end
003
004 subroutine sub
005 use global
006 15 real, save :: a[*] ! The images 1, 2, 3, and 4
007 : ! correspond to node(5:8), respectively.
008 if(this_image().eq.1)then ! The value of the coarray a on node(5)
009 s[1] = a ! defines that of the coarray s on node(1)
010 endif
011 20
012
013
014
015
016
017
018
019
020
021
022
023
024
025
026
027
028
029
030
031
032
033
034
035
036
037
038
039
040
041
042
043
044
045
046
047
048
049
050
051
052
053
054
055
056
057

```

## 4.4 image Directive

### 4.4.1 Purpose and Form of the image Directive

The `image` directive specifies that an image index in the following executable statement indicates the on-node image index of the node array specified in the `image` directive unless the image index is determined by an image selector.

The `image` directive also specifies that execution of a `sync all` statement performs a synchronization of all the images corresponding to the node array specified in the `image` directive.

[F] `!$xmp image ( node-name )`

[C] `#pragma xmp image ( node-name )`

- An `image` directive shall be followed by a `sync all` statement, an image control statement that contains *image-set*, or a reference to an intrinsic procedure that has `IMAGES` argument.

### 4.4.2 An Example of the image Directive

```

036 XcalableMP Fortran
037 module global
038 !$xmp nodes node(8)**
039 real s[*] ! The coarray s is always visible
040 !$xmp coarray on node :: s ! on node(1:8).
041 end global
042 5
043
044 program image
045 use global
046 !$xmp tasks
047 10 !$xmp task on node(1:4)
048 call subA ! The executing node set consists of node(1:4).
049 !$xmp end task
050 !$xmp task on node(5:8)
051 call subB ! The executing node set consists of node(5:8).
052 15 !$xmp end task
053 !$xmp end tasks
054 end
055
056 subroutine subA
057

```

```

20 use global
 real, save :: a[*] ! The images 1, 2, 3, and 4
 : ! correspond to node(1:4), respectively.
!$xmp image(node) ! Synchronization between node(1:4) and
 sync images(5) ! node(5).
25 a = s[1] ! a on node(1:4) is defined with
 : ! the value of s on node(1).
 end subroutine

 subroutine subB
 use global
30 real, save :: b[*] ! The images 1, 2, 3, and 4
 : ! correspond to node(5:8), respectively.
 if(this_image() .eq. 1)then ! The image 1 indicates node(5).
 s[1] = b ! s on node(1) is defined with the value of
35 : ! b on node(5).
!$xmp image(node) ! Synchronization between
 sync images((/1,2,3,4/)) ! node(5) and node(1:4).
 endif
 :
40 end subroutine

```

## 4.5 Image Index Translation Intrinsic Procedures

XscalableMP supports intrinsic procedures to translate image indices between different sets of images.

### 4.5.1 Translation to the Primary Image Index

`xmp_get_primary_image_index(NUMBER,INDEX,PRI_INDEX,NODE_DESC)`

**Description.** Translate image indices to the primary image indices.

**Class.** Subroutine.

**Arguments.**

**NUMBER** shall be a scalar of type default integer. It is an INTENT(IN) argument.

**INDEX** shall be a rank-one array of type default integer. The size of **INDEX** shall be greater than or equal to the value of **NUMBER**. It is an INTENT(IN) argument. The value of each element of **INDEX** shall be in the range one to the size of the node array specified in **NODE\_DESC** if **NODE\_DESC** appears. The value of each element of **INDEX** shall be in the range one to the cardinality of the current set of images if **NODE\_DESC** does not appear.

**PRI\_INDEX** shall be a rank-one array of type default integer. The size of **PRI\_INDEX** shall be greater than or equal to the value of **NUMBER**. It is an INTENT(OUT) argument. If **NODE\_DESC** appears, **PRI\_INDEX(i)** is assigned the primary image index corresponding to the element of the node array specified in **NODE\_DESC** whose subscript order value is **INDEX(i)**; otherwise, **PRI\_INDEX(i)** is assigned the primary image index corresponding to the image whose current image index is **INDEX(i)**.

**NODE\_DESC** (optional) shall be a descriptor of a node array. It is an INTENT(IN) argument. **NODE\_DESC** shall appear in XcalableMP C.

**Example.** In the following code fragment, the value of `index(1:4)` is (/5,6,7,8/).

```

001 XcalableMP Fortran
002 -----
003
004 !$xmp nodes node(1:8)=** ! A primary node array
005
006 !$xmp nodes subnode(4)=node(5:8)
007
008 integer index(4)
009 call xmp_get_primary_image_index&
010 &(4, (/1,2,3,4/), index, xmp_desc_of(subnode))
011
012
013
014

```

## 4.5.2 Translation to the Current Image Index

`xmp_get_image_index(NUMBER,INDEX,CUR_INDEX,NODE_DESC)`

**Description.** Translate image indices to the current image indices.

**Class.** Subroutine.

**Arguments.**

**NUMBER** shall be a scalar of type default integer. It is an INTENT(IN) argument.

**INDEX** shall be a rank-one array of type default integer. The size of **INDEX** shall be greater than or equal to the value of **NUMBER**. It is an INTENT(IN) argument. The value of each element of **INDEX** shall be in the range one to the size of the node array specified in **NODE\_DESC**.

**CUR\_INDEX** shall be a rank-one array of type default integer. The size of **CUR\_INDEX** shall be greater than or equal to the value of **NUMBER**. It is an INTENT(OUT) argument. If the current image index corresponding to the element of the node-array specified in **NODE\_DESC** whose subscript order value is **INDEX(i)** exists, **CUR\_INDEX(i)** is assigned the current image index; otherwise, **CUR\_INDEX(i)** is assigned zero.

**NODE\_DESC** shall be a descriptor of a node array. It is an INTENT(IN) argument.

**Example.** In the following code fragment, the value of `index(1:4)` is (/1,2,3,4/).

```

040 XcalableMP Fortran
041 -----
042
043 !$xmp nodes node(1:8)=**
044 integer index(4)
045
046 !$xmp task on node(5:8)
047 call xmp_get_image_index&
048 &(4, (/5,6,7,8/), index, xmp_desc_of(node))
049
050 !$xmp end task
051
052
053
054

```

## 4.6 Examples of Communication between Tasks

- In the following program fragment, two tasks communicate with each other with synchronization.

```

054 XcalableMP Fortran
055 -----
056
057 module nodes
058
059 !$xmp nodes node(8)=** ! A primary node array
060
061 integer, parameter :: n=2

```

```

5 !$xmp nodes subnodeA(n)=node(1:n) ! subnodeA is for taskA.
 !$xmp nodes subnodeB(8-n)=node(n+1:8) ! subnodeB is for taskB.
 endmodule

 module intertask
 use nodes
10 real,save :: dA[*],dB[*]
 endmodule

 use nodes
 !$xmp tasks
15 !$xmp task on subnodeA ! The taskA is invoked on subnodeA.
 call taskA
 !$xmp end task
 !$xmp task on subnodeB ! The taskB is invoked on subnodeB.
 call taskB
20 !$xmp end task
 !$xmp end tasks
 end

 subroutine taskA
25 use intertask
 :
 me = this_image() ! The value of me is i on subnodeA(i).
 if(me.eq.1)then
 call xmp_get_primary_image_index& ! The value of iyouabs
 &(1,(/1/),iyouabs,subnodeB) ! is n+1.
30 !$xmp image(node) ! Synchronization between
 sync images(iyouabs) ! node(1) and node(n+1).
 call exchange(dA,dB,iyouabs)
 !$xmp image(node) ! Synchronization between
35 sync images(iyouabs) ! node(1) and node(n+1).
 endif
 sync all ! Synchronization within subnodeA.
 if(me.ne.1)dA = dA[1]
 sync all ! Synchronization within subnodeA.
40 :
 end

 subroutine taskB
45 use intertask
 :
 me = this_image() ! The value of me is i on subnodeB(i).
 if(me.eq.1)then
 call xmp_get_primary_image_index& ! The value of iyouabs
 &(1,(/1/),iyouabs,subnodeA) ! is 1.
50 !$xmp image(node) ! Synchronization between
 sync images(iyouabs) ! node(n+1) and node(1).
 call exchange(dB,dA,iyouabs)
 !$xmp image(node) ! Synchronization between
55 :
56 :
57 :

```

```

001 sync images(iyouabs) ! node(n+1) and node(1).
002 55 endif
003 sync all ! Synchronization within subnodeB.
004 if(me.ne.1)dB = dB[1]
005 sync all ! Synchronization within subnodeB.
006
007
008 60 end
009
010 subroutine exchange(mine,yours,iput)
011 use nodes
012 real :: mine[*],yours[*] ! mine and yours are always
013 65 !$xmp coarray on node :: mine,yours ! visible on node(1:8).
014
015
016 yours[iput] = mine ! node(1) puts mine to yours[n+1] and
017 ! node(n+1) puts mine to yours[1].
018
019 end

```

- In the following program fragment, two tasks communicate with each other without one-to-one synchronization.

```

023 XscalableMP Fortran
024 !$xmp nodes node(8)=** ! A primary node array
025 :
026 !$xmp tasks
027 !$xmp task on(node(1:n))
028 5 call taskA(n) ! The taskA is invoked on node(1:n)
029 !$xmp end task
030 !$xmp task on(node(n+1:8))
031 call taskB(8-n) ! The taskB is invoked on node(n+1:8)
032 !$xmp end task
033 !$xmp end tasks
034 10 !$xmp end tasks
035 end
036
037 subroutine taskA(n)
038 real,save :: yours[*],mine[*]
039 15 !$xmp nodes subnode(n)=* ! An executing node array
040
041 me = this_image()
042 if(me.eq. NUM_IMAGES())then
043 call xmp_get_primary_image_index(1,me,meabs) ! meabs=n.
044 call exchange(yours,mine,meabs,meabs+1,NUM_IMAGES())
045 20 endif
046 sync all ! Synchronization within node(1:n).
047 if(me.ne.NUM_IMAGES())mine = mine[NUM_IMAGES()]
048 sync all ! Synchronization within node(1:n).
049 25 end
050
051 subroutine taskB(m)
052 real,save :: yours[*],mine[*]
053 30 !$xmp nodes subnode(m)=* ! An executing node array

```

```

 me = this_image()
 if(me.eq.1)then
 call xmp_get_abs_image_index(1,me,meabs) ! meabs=n+1.
 call exchange(yours,mine,meabs,meabs-1,NUM_IMAGES())
 endif
35 sync all ! Synchronization within node(n+1:8).
 if(me.ne.1)mine = mine[1]
 sync all ! Synchronization within node(n+1:8).
 end

40
 subroutine exchange(yours,mine,meabs,iyouabs,nnodes)
 USE, INTRINSIC :: ISO_FORTRAN_ENV
 real :: yours[*],mine[*]
 real, save :: s[*] ! only for exchange.
45 TYPE(LOCK_TYPE),save :: lock[*] ! for lock.
!$xmp nodes subnode(nnodes)=* ! An executing node array.
!$xmp nodes node(8)=** ! The coarrays s and lock are
!$xmp coarray on node :: s,lock ! always visible on node(1:8).

50 LOCK(lock[meabs]) ! node(n) puts yours[n] to s[n] and
 s[meabs] = yours ! node(n+1) puts yours[n+1] to s[n+1].
 UNLOCK(lock[meabs])

 LOCK(lock[iyouabs]) ! node(n) gets s[n+1] into mine[n] and
55 mine = s[iyouabs] ! node(n+1) gets s[n] into mine[n+1].
 UNLOCK(lock[iyouabs])
 end

```

## 4.7 [C] Coarrays in XcalableMP C.

This section describes the coarray features for XcalableMP C.

### 4.7.1 [C] Declaration of Coarrays

#### Synopsis

Coarrays are declared in XcalableMP C.

#### Syntax

```
[C] data-type variable [, variable]... : codimensions
```

where *codimensions* is:

```
/[int-expr].../[*]
```

#### Description

For XcalableMP C, coarrays are declared with a colon and square bracket where *codimensions* specify the coshape of a variable.

Note that, the `coarray` directive for defining a coarray in the XcalableMP specification 1.0 (page 49) is obsolete.

### Restrictions

- A coarray *variable* must have a global scope.

### Examples

```

_____ XcalableMP C _____
#pragma xmp nodes p(16)
float x:[*];

```

A variable *x* that has a global scope is declared as a coarray.

## 4.7.2 [C] Reference of Coarrays

### Synopsis

A coarray can be directly referenced or defined by any node. The target node is specified using an extended notation in XcalableMP C.

### Syntax

```
[C] variable : [int-expr]...
```

### Description

A sequence of [*int-expr*]'s preceded by a colon in XcalableMP C determines the image index for a coarray to be accessed.

An reference of coarrays can appear in the same place as an reference of normal variables in the base languages.

### Examples

In the following code, each executing node gets whole of B from the image 10 (that is, the tenth node of the entire node set) and copies it into the local storage for A.

```

_____ XcalableMP C _____
int A[10]:[*], B[10]:[*];

A[:] = B[:]:[10];

```

## 4.7.3 [C] Synchronization of Coarrays

### Synopsis

XcalableMP C provides synchronization functions for coarrays.

### Format

```

[C] void xmp_sync_all(int* status)
[C] void xmp_sync_memory(int* status)
[C] void xmp_sync_image(int image, int* status)
[C] void xmp_sync_images(int num, int* image_set, int* status)
[C] void xmp_sync_images.all(int* status)

```

## Description

- `xmp_sync_all` is equivalent to the `sync all` statement in Fortran 2008.
- `xmp_sync_memory` is equivalent to the `sync memory` statement in Fortran 2008.
- A combination of `xmp_sync_image`, `xmp_sync_images`, and `xmp_sync_images_all` is equivalent to the `sync memory` statement in Fortran 2008.
  - `xmp_sync_image` is to synchronize one image.
  - `xmp_sync_images` is to synchronize some images.
  - `xmp_sync_images_all` is to synchronize all images.

## Arguments

- The argument *status* is defined with one of the follow symbolic constants.
  - `XMP_STAT_SUCCESS`
  - `XMP_STAT_STOPPED_IMAGE`

If an execution of the function is success, the *status* is defined with `XMP_STAT_SUCCESS`. A condition where the *status* is defined with `XMP_STAT_STOPPED_IMAGE` is the same as that where the *status* is defined with `STAT_STOPPED_IMAGE` in Fortran 2008. These symbolic constants are defined in “xmp.h”. If any other error condition occurs during execution of these functions, the *status* is defined with a value which is different from the value of `XMP_STAT_SUCCESS` and `XMP_STAT_STOPPED_IMAGE`.

- In `xmp_sync_image`, the variable *image* determines a target image index.
- In `xmp_sync_images`, the variable *num* is a number of target images, and the variable *image\_set* is an array where target images set is defined.

## 4.8 Directives for the Local-view Programming

### 4.8.1 [F] `local_alias` Directive

#### Synopsis

In XcalableMP Fortran, the `local_alias` directive declares a local data object as an alias to the local section of a mapped array.

#### Syntax

```
[F] !$xmp local_alias local-array-name => global-array-name
```

#### Description

The `LOCAL_ALIAS` directive associates a non-mapped array with an explicitly mapped array. The non-mapped array is an associating local array and the explicitly mapped array is an associated global array. The shape of the associating local array is the same as that of the node-local portion of the associated global array including shadow area. Each element of the associating local array shares the same storage unit in array element order with that of the node-local portion of the associated global array. An associating local array and the corresponding



global array always have the same allocation status. An associating local array always has the dynamic type and type parameter values of the corresponding associated global array.

An associating local array may be a coarray. An associating local array that is a coarray is an on-node coarray of the node array onto which the corresponding associated global array is mapped. Every specification and restriction on coarrays is also applied to an associating local array that is a coarray except that an associating local array is always declared with *deferred-shape-spec-list* of the same rank as the associated global array. In particular, a processor shall ensure that an associating local array that is a coarray has the same bounds on all the images corresponding to the node array onto which the corresponding associated global array is mapped. The mapping attributes allowed for an associated global array are processor-dependent.

Note that the base language Fortran is extended so that a deferred-shape array that is not either an allocatable array or an array pointer is declared if it is specified as a *local-array-name* in the `local_alias` directive.

In XcalableMP C, the `address-of` operator applied to global data substitutes for the `local_alias` directive (see 5.4).

## Restrictions

- A *global-array-name* shall be a name of an explicitly mapped array declared in the same scoping unit.
- A *local-array-name* shall be a name of a non-mapped array declared in the same scoping unit.
- A *local-array-name* shall not be a dummy argument.
- An associating local array shall have the declared type and type parameters of the corresponding associated global array.
- An associating local array shall be declared with *deferred-shape-spec-list* of the same rank as the corresponding associated global array.
- A *local-array-name* shall appear in a `COARRAY` directive in the same scoping unit and the *node-name* in the `COARRAY` directive shall be the name of the node array onto which the associated global array is mapped.
- If an associated global array is a dummy argument and corresponds to an associating local array that is a coarray, the corresponding effective argument shall be an explicitly mapped array or a subobject of an explicitly mapped array whose name appears in a `LOCAL_ALIAS` directive and the corresponding associating local array shall be a coarray.
- If a dummy argument is a coarray and the corresponding ultimate argument is a coarray appearing in a `LOCAL_ALIAS` directive, the dummy argument shall appear in a `COARRAY` directive with a node array corresponding to a subset of the set of images that corresponds to the node array onto which the ultimate argument is mapped.

## Examples

### Example 1

```

XcalableMP Fortran
!$xmp nodes n(4)
!$xmp template :: t(100)
!$xmp distribute (block) onto n :: t
```

```

5 real :: a(100)
!$xmp align (i) with t(i) :: a
!$xmp shadow (1) :: a

 real :: b(:)
10 !$xmp local_alias b => a

```

The array **a** is distributed by block onto four nodes. The node **n(2)** has its local section of twenty-five elements (**a(25:50)**) with shadow areas of size one on both of the upper and lower bounds. The local alias **b** is an array of 27 elements (**b(1:27)**) on **n(2)**. The table below shows the correspondence of each element of **a** to that of **b** on **n(2)**.

| a            | b   |
|--------------|-----|
| lower shadow | 1   |
| 26           | 2   |
| 27           | 3   |
| 28           | 4   |
| ...          | ... |
| 50           | 26  |
| upper shadow | 27  |

### Example 2

```

XcalableMP Fortran
!$xmp nodes n(4)
!$xmp template :: t(100)
!$xmp distribute (cyclic) onto n :: t

5 real :: a(100)
!$xmp align (i) with t(i) :: a

 real :: b(0:)
!$xmp local_alias b => a

```

An array **a** is distributed cyclically onto four nodes. Node **n(2)** has its local section of twenty-five elements (**a(2:100:4)**). The lower bound of local alias **b** is declared to be zero. As a result, **b** is an array of size 25 whose lower bound is zero (**b(0:24)**) on **n(2)**. The table below shows the correspondence of each element of **a** to that of **b** on **n(2)**.

| a   | b   |
|-----|-----|
| 2   | 0   |
| 6   | 1   |
| 10  | 2   |
| ... | ... |
| 98  | 24  |

### Example 3

```

001 XcalableMP Fortran
002 !$xmp nodes n(4)
003 !$xmp template :: t(:)
004 !$xmp distribute (block) onto n :: t
005
006
007 5 real, allocatable :: a(:)
008 !$xmp align (i) with t(i) :: a
009
010 real :: b(:)[*]
011 !$xmp local_alias b => a
012
013 10 ...
014
015
016 !$xmp template_fix :: t(128)
017
018 15 allocate (a(128))
019
020 if (me < 4) b(4) = b(4)[me +1]
021

```

Since the global array `a` is an allocatable array, its local alias `b` is not defined when the subroutine starts execution. `b` is defined when `a` is allocated at the `allocate` statement. Note that `b` is declared as a coarray and therefore can be accessed in the same manner as a normal coarray.

## 4.8.2 post Construct

### Synopsis

The `post` construct, in combination with the `wait` construct, specifies a point-to-point synchronization.

### Syntax

```

038 [F] !$xmp post (nodes-ref, tag)
039 [C] #pragma xmp post (nodes-ref, tag)

```

### Description

This construct ensures that the execution of statements that precede it is completed before statements that follow the matching `wait` construct start to be executed.

A `post` construct issued with the arguments of `nodes-ref` and `tag` on a node (called a *posting node*) dynamically matches at most one `wait` construct issued with the arguments of the posting node (unless omitted) and the same value as `tag` (unless omitted) by the node specified by `nodes-ref`.

### Restriction

- `nodes-ref` must represent one node.
- `tag` must be an expression of type default integer, in XcalableMP Fortran, or type `int`, in XcalableMP C.

**Example****Example 1**

|                                                   |                                                   |
|---------------------------------------------------|---------------------------------------------------|
| XcalableMP Fortran<br>S1<br>!\$xmp post (p(2), 1) | XcalableMP Fortran<br>!\$xmp wait (p(1), 1)<br>S2 |
|---------------------------------------------------|---------------------------------------------------|

It is assumed that the code of the left is executed by the node p(1) while that on the right is executed by node p(2).

The `post` construct on the left matches the `wait` construct on the right because their *nodes-refs* represent each other and both *tags*'s have the same value of 1. These constructs ensure that no statement in S2 is executed by p(2) until the execution of all statements in S1 is completed by p(1).

**Example 2**

|                                         |
|-----------------------------------------|
| XcalableMP Fortran<br>!\$xmp wait<br>S3 |
|-----------------------------------------|

It is assumed that this code is executed by node p(2).

The `post` construct in the left code in Example 1 may matches this `wait` construct because both *nodes-ref* and *tag* are omitted in this `wait` construct.

**4.8.3 wait Construct****Synopsis**

The `wait` construct, in combination with the `post` construct, specifies a point-to-point synchronization.

**Syntax**

```
[F] !$xmp wait [(nodes-ref [, tag])]
[C] #pragma xmp wait [(nodes-ref [, tag])]
```

**Description**

This construct prohibits statements that follow this construct from being executed until the execution of all statements preceding a matching `post` construct is completed on the node specified by *node-ref*.

A `wait` construct issued with the arguments of *nodes-ref* and *tag* on a node (called a *waiting node*) dynamically matches a `post` construct issued with the arguments of the waiting node and the same value as *tag* by the node specified by *nodes-ref*.

If *tag* is omitted, then the `wait` construct can match a `post` construct issued with the arguments of the waiting node and any tag by the node specified by *nodes-ref*. If both *tag* and *nodes-ref* are omitted, then the `wait` construct can match a `post` construct issued with the arguments of the waiting node and any tag on any node.

**Restriction**

- *nodes-ref* must represent one node.
- *tag* must be an expression of type default integer, in XcalableMP Fortran, or type `int`, in XcalableMP C.

#### 4.8.4 [C] lock/unlock Construct

##### Synopsis

The lock/unlock constructs are equivalent to the lock/unlock statements in Fortran 2008.

##### Syntax

```
[C] #include <xmp.h>
[C] xmp_lock_t lock-object [, lock-object]...
[C] #pragma xmp lock (lock-object) [acquired_lock (success)] [stat (status)]
[C] #pragma xmp unlock (lock-object) [stat (status)]
```

Please note the following points:

- The type `xmp_lock_t` is defined in “xmp.h”.
- The variable `lock-object` is a coarray.
- The variable `success` is an expression of type `int`.
- The variable `status` is an expression of type `int`.

##### Description

The `lock` construct, in combination with the `unlock` construct, is used to control a `lock-object`. The `lock-object` must be defined as a coarray to control it on a target node. The `lock-object` must be an expression of type `xmp_lock_t` which is an opaque object defined in “xmp.h”.

If the `acquired_lock` clause is not used in the `lock` construct and the `lock-object` is locked, a node stops at the `lock` construct until the `lock-object` is unlocked by a different node. If the `acquired_lock` clause is used in the `lock` construct and the `lock-object` is locked by a different node, a node does not stop at the `lock` construct and the variable `success` is defined with the value `false` and `lock` construct leaves the `lock-object` unchanged. If the `acquired_lock` clause is used in the `lock` construct and the `lock-object` is unlocked, the variable `success` is defined with the value `true`.

The `status` is defined with one of the follow symbolic constants when executing `lock/unlock` construct.

- `XMP_STAT_SUCCESS`
- `XMP_STAT_LOCKED`
- `XMP_STAT_UNLOCKED`
- `XMP_STAT_LOCKED_OTHER_IMAGE`

If an execution of `lock/unlock` construct is success, the `status` is defined with `XMP_STAT_SUCCESS`. A condition where the `status` is defined with `XMP_STAT_LOCKED`, `XMP_STAT_UNLOCKED`, or `XMP_STAT_LOCKED_OTHER_IMAGE` is the same as that where the `status` is defined with `STAT_LOCKED`, `STAT_UNLOCKED`, or `STAT_LOCKED_OTHER_IMAGE` in Fortran 2008. These symbolic constants are defined in “xmp.h”. If any other error condition occurs during execution of these constructs, the `status` is defined with a value which is different from the value of `XMP_STAT_SUCCESS`, `XMP_STAT_LOCKED`, `XMP_STAT_UNLOCKED`, and `XMP_STAT_LOCKED_OTHER_IMAGE`.

**Example**

```
----- XcalableMP C -----
#include "xmp.h"

xmp_lock_t lock_obj:[*];
int A:[*], B;
5 #pragma xmp nodes p(2)
 ...
 #pragma xmp lock(lock_obj:[2])
 if(xmp_node_num() == 1){
 A:[2] = B;
10 }
 #pragma xmp unlock(lock_obj:[2])
```

001  
002  
003  
004  
005  
006  
007  
008  
009  
010  
011  
012  
013  
014  
015  
016  
017  
018  
019  
020  
021  
022  
023  
024  
025  
026  
027  
028  
029  
030  
031  
032  
033  
034  
035  
036  
037  
038  
039  
040  
041  
042  
043  
044  
045  
046  
047  
048  
049  
050  
051  
052  
053  
054  
055  
056  
057

001  
002  
003  
004  
005  
006  
007  
008  
009  
010  
011  
012  
013  
014  
015  
016  
017  
018  
019  
020  
021  
022  
023  
024  
025  
026  
027  
028  
029  
030  
031  
032  
033  
034  
035  
036  
037  
038  
039  
040  
041  
042  
043  
044  
045  
046  
047  
048  
049  
050  
051  
052  
053  
054  
055  
056  
057

001  
002  
003  
004  
005  
006  
007  
008  
009  
010  
011  
012  
013  
014  
015  
016  
017  
018  
019  
020  
021  
022  
023  
024  
025  
026  
027  
028  
029  
030  
031  
032  
033  
034  
035  
036  
037  
038  
039  
040  
041  
042  
043  
044  
045  
046  
047  
048  
049  
050  
051  
052  
053  
054  
055  
056  
057

## Chapter 5

# Base Language Extensions in XcalableMP C

This chapter describes base language extensions in XcalableMP C that is not described in any other chapters.

### 5.1 Array Section Notation

#### Synopsis

The array section notation is a notation to describe a part of an array, which is adapted in Fortran.

#### Syntax

[C] *array-section* is *array-name*[ { *triplet* | *int-expr* } ]...

where *triplet* must be one of:

*base* : *length* : *step*  
*base* : *length*  
:

#### Description

In XcalableMP C, the base language C is extended so that a part of an array, that is, an array section can be put in an *array assignment statement*, which is described in 5.2, and some XcalableMP constructs. An array section is built from a subset of the elements of an array, which is specified by this notation including at least one *triplet*.

When *step* is positive, the *triplet* specifies a set of subscripts that is a regularly spaced integer sequence of length *length* beginning with *base* and proceeding in increments of *step* up to the largest. When *step* is negative, the *triplet* specifies a set of subscripts that is a regularly spaced integer sequence of length *length* beginning with *base* and proceeding in increments of *step* down to the smallest.

When *step* is omitted, it is assumed to be “1”. When all of *base*, *length* and *step* is omitted, it is assumed that *base* is “0”, *length* is the size of the dimension of the array, and *step* is “1”.

An array section can be considered as a virtual array containing the set of elements from the original array determined by all possible subscript lists specified by the sequence of *triplet*'s or *int-expr*'s in square brackets.



**Restrictions**

- [C] Each of *base*, *length* and *step* must be an integer expression.
- [C] *length* must be greater than zero.
- [C] *step* must not be zero.

**Example**

Assuming that an array *A* is declared by the following statement,

```
int A[100];
```

some array sections can be specified as follows:

|           |                                                           |
|-----------|-----------------------------------------------------------|
| A[10:10]  | array section of 10 elements from A[10] to A[19]          |
| A[10:]    | array section of 90 elements from A[10] to A[99]          |
| A[:10]    | array section of 10 elements from A[0] to A[9]            |
| A[10:5:2] | array section of 5 elements from A[10] to A[18] by step 2 |
| A[:]      | the whole of A                                            |

**5.2 Array Assignment Statement****Synopsis**

An array assignment statement copies a value into each element of an array section.

**Syntax**

```
[C] array-section [: [int-expr]...] = { variable [: [int-expr]...] | int-expr };
```

**Description**

When the rhs is an array section, the value of each element of it is assigned to the corresponding element of the lhs array section. When the rhs is an integer expression, its value is assigned to each element of the lhs array section.

The rhs and/or the lhs data can have cosubscripts.

Note that an array assignment is a statement and therefore cannot appear as an expression in any other statements.

**Restrictions**

- [C] When the rhs is an array section, the lhs and the rhs must have the same shape, i.e., the same number of dimensions and size of each dimension.
- [C] If *array-section* on the lhs is followed by “: [*int-expr*]...”, it must be a coarray.
- [C] If *variable* on the rhs is followed by “: [*int-expr*]...”, it must be a coarray.

## Examples

An array assignment statement in the fourth line copies the elements B[0] through B[4] into the elements A[5] through A[9].

```
_____ XcalableMP C _____
int A[10];
int B[5];
 ...
A[5:5] = B[0:5];
```

## 5.3 Built-in Functions for Array Section

Some built-in functions are defined that can accept one or more array sections as arguments, and, in addition, some of them are array-valued. Such array-valued functions can appear in the right-hand side of an array assignment statement, and should be preceded by the `array` directive if the array section is distributed.

Each of the built-in functions for array section are described in Sections 7.7 and 7.8.

## 5.4 Pointer to Global Data

### 5.4.1 Name of Global Array

The name of a global array is considered to represent an abstract entity in the XcalableMP language. It is not interpreted as the pointer to the array, while the name of a local array is.

However, the name of a global array appeared in an expression is evaluated to the pointer to the base address of its local section on each node. The pointer, as a normal (local) pointer, can be operated on each node.

### 5.4.2 The Address-of Operator

The result of the address-of operator (“&”) applied to an element of a global array is the pointer to the corresponding element of its local section. Note that the value of the result pointer is defined only on the node that owns the element. The pointer, as a normal (local) pointer, can be operated on the node.

As a result, for a global array `a`, `a` and `&a[0]` are not always evaluated to the same value.

## 5.5 Dynamic Allocation of Global Data

In XcalableMP C, it is possible to allocate global arrays at runtime only when they are one-dimensional. Such allocation is done through the following steps.

1. Declare a pointer to an object of the type of the global array to be allocated.
2. Align the pointer with a template as if it were a one-dimensional array.
3. Allocate a storage of the global size with the `xmp_malloc` library procedure and assign the result value to the pointer on each node.

The specification of `xmp_malloc` is described in section 7.4.1.

## Example

A pointer `pa` to a float is declared in line 5 and aligned with a template `t` in line 6. `t` is initially undefined and fixed by the `template_fix` directive in line 10. The storage for a global data, that is, each of its local section is allocated with `xmp_malloc` and `pa` is set to point it on each node in line 12. For details of the operator `xmp_desc_of`, refer to the next section.

```

001
002
003
004
005
006
007
008
009
010
011
012
013
014
015
016
017
018
019
020
021
022
023
024
025
026
027
028
029
030
031
032
033
034
035
036
037
038
039
040
041
042
043
044
045
046
047
048
049
050
051
052
053
054
055
056
057

```

XcalableMP C

```

#pragma nodes p(NP)
#pragma xmp template t(:)
#pragma xmp distribute t(block) onto p

5 float *pa;
#pragma xmp align pa[i] with t(i)

...

10 #pragma xmp template_fix t(N)

pa = (float *)xmp_malloc(xmp_desc_of(pa), N);

```

## 5.6 The Descriptor-of Operator

The descriptor-of operator (“`xmp_desc_of`”) is introduced as a built-in operator in XcalableMP C.

The result of the descriptor-of operator applied to XcalableMP entities such as node arrays, templates and global arrays is their *descriptor*, which can be used, for example, as an argument of some inquiry procedures. The type of the result, `xmp_desc_t`, is implementation-dependent, and defined in the `xmp.h` header file in XcalableMP C.

For the `xmp_desc_of` intrinsic function in XcalableMP Fortran, refer to section 7.1.1.

## Chapter 6

# Procedure Interfaces

This chapter describes the procedure interfaces, that is, how procedures are invoked and arguments are passed, in XcalableMP.

In order to achieve high composability of XcalableMP programs, it is one of the most important requirement that XcalableMP procedures can invoke procedures written in the base language with as a few restrictions as possible.

### 6.1 General Rule

In XcalableMP, a procedure invocation itself is a local operation and does not cause any communication or synchronization at runtime. Thus, a node can invoke any procedure, whether written in XcalableMP or in the base language, at any point of the execution. There is no restriction on the characteristics of procedures invoked by an XcalableMP procedure, except for a few ones on its argument, which is explained below.

A local data in the actual or dummy argument list (referred to as a *local actual argument* and a *local dummy argument*, respectively) are treated by the XcalableMP compiler in the same manner as by the compiler of the base language. This rule makes it possible that a local actual argument in a procedure written in XcalableMP can be associated with a dummy argument of a procedure written in the base language.

If both of an actual and its associating dummy arguments are coarrays, they must be declared on the same node set.

**Implementation.** The XcalableMP compiler does not transform either local actual or dummy arguments, so that the backend compiler of the base language can treat them in its usual way.

The rest of this chapter specifies how global data appearing as an actual and a dummy argument list (referred to as a *global actual argument* and a *global dummy argument*, respectively) are processed by the XcalableMP compiler.

### 6.2 Argument Passing Mechanism in XcalableMP Fortran

Either of the following global data can be put in the actual argument list:

- an array name;
- an array element; or
- an array section that satisfies both of the following two conditions:

- its subscript list is a list of zero or more colons (“:”) followed by zero or more *int-expr*’s;
- a subscript of the dimension having shadow is *int-expr* unless it is the last dimension.

There are two kinds of argument association for global data in XcalableMP Fortran: one is *sequence association*, which is for a global dummy that is an explicit-shape or assumed-size array, and the other is *descriptor association*, which is for all other global dummy.

### 6.2.1 Sequence Association of Global Data

The concept of sequence association in Fortran is extended for global actual and dummy arguments in XcalableMP as follows.

If the actual argument is an array name or an array section that satisfies the above conditions, it represents an element sequence consisting of the elements of its local section in Fortran’s array element order on each node. Also, if the actual argument is an element of a global data, it represents an element sequence consisting of the corresponding element in the local section and each element that follows it in array element order on each node.

An global actual argument that represents an element sequence and corresponds to a global dummy argument is sequence associated with the the dummy argument if the dummy argument is an explicit-shape or assumed-size array. According to this (extended) sequence association rule, each element of the element sequence represented by the global actual argument is associated with the element of the local section of the global dummy argument that has the same position in array element order.

Sequence association is the default rule of association for global actual arguments and therefore is applied unless it is obvious from the interface of the invoked procedure that the corresponding dummy argument is neither an explicit-shape nor assumed-size array.

**Implementation.** In order to implement sequence association, the name, a section, or an element of a global data appearing as an actual argument is treated by the XcalableMP compiler as the base address of its local section on each node, and the global data appearing as the corresponding dummy argument is initialized at runtime so as to be composed of the local sections each of which starts from the address received as the argument. On a node that does not have the local section corresponding to the actual argument, an unspecified value (e.g. null) is received.

Such implementation implies that in many cases, in order to associate properly a global actual argument with the global dummy argument, their mappings (including their shadow attributes) must be identical.

#### Examples

**Example 1** Both the actual argument *a* and the dummy argument *x* are global explicit-shape arrays, and therefore *a* is sequence associated with *x*.

It is the base address of the local section of *a* that passed between these subroutines on each node. Each the local section of *x* starts from the received address (Figure 6.1).

```

XcalableMP Fortran
subroutine xmp_sub1
!$xmp nodes p(4)
!$xmp template t(100)
!$xmp distribute t(block) onto p
real a(100)
```

```

!$xmp align a(i) with t(i)
!$xmp shadow a(1:1)
 call xmp_sub2(a)
 end subroutine

10
 subroutine xmp_sub2(x)
!$xmp nodes p(4)
!$xmp template t(100)
!$xmp distribute t(block) onto p
15
 real x(100)
!$xmp align x(i) with t(i)
!$xmp shadow x(1:1)
 ...

```

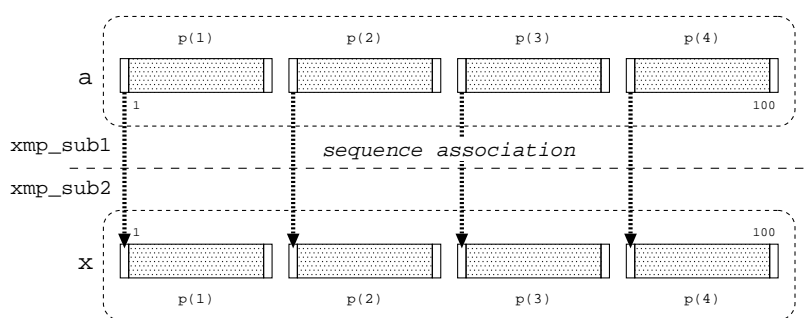

Figure 6.1: Sequence Association with a Global Dummy Argument

**Example 2** The actual argument `a` is a global explicit-shape array, and the dummy argument `x` is a local explicit-shape. Sequence association is applied also in this case.

The caller subroutine `xmp_sub1` passes the base address of the local section of `a` on each node, and the callee `f_sub2` receives it and initializes `x` with the storage starting from it (Figure 6.2).

```

----- XcalableMP Fortran -----
 subroutine xmp_sub1
!$xmp nodes p(4)
!$xmp template t(100)
!$xmp distribute t(block) onto p
5
 real a(100)
!$xmp align a(i) with t(i)
!$xmp shadow a(1:1)
 n = 1 + 100/4 + 1
 call f_sub2(a,n)
10
 end subroutine

```

```

----- Fortran -----
 subroutine f_sub2(x,n)
 real x(n)
 ...

```

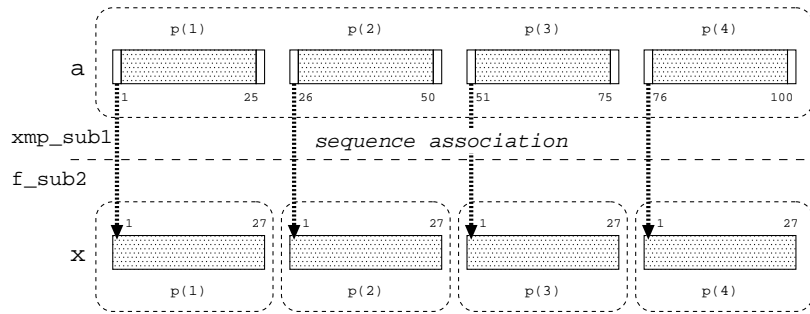

Figure 6.2: Sequence Association with a Local Dummy Argument

**Example 3** The actual argument  $a(:,1)$  is a contiguous section of the global data, and the dummy argument  $x$  is a local explicit-shape array. Sequence association is applied in this case, but only the node  $p(1)$  owns the section. Hence,  $f\_sub2$  is invoked only by  $p(1)$  (Figure 6.3).

```

020 XscalableMP Fortran
021
022 subroutine xmp_sub1
023 !$xmp nodes p(4)
024 !$xmp template t(100,100)
025 !$xmp distribute t(*,block) onto p
026 5 real a(100,100)
027 !$xmp align a(i,j) with t(i,j)
028 !$xmp shadow a(0,1:1)
029 n = 100
030 !$xmp task on p(1)
031 10 call f_sub2(a(:,1),n)
032 !$xmp end task
033 end subroutine
034
035 Fortran
036
037 subroutine f_sub2(x,n)
038 real x(n)
039 ...
040
041
042
043
044
045
046
047
048
049
050
051
052
053
054
055
056
057

```

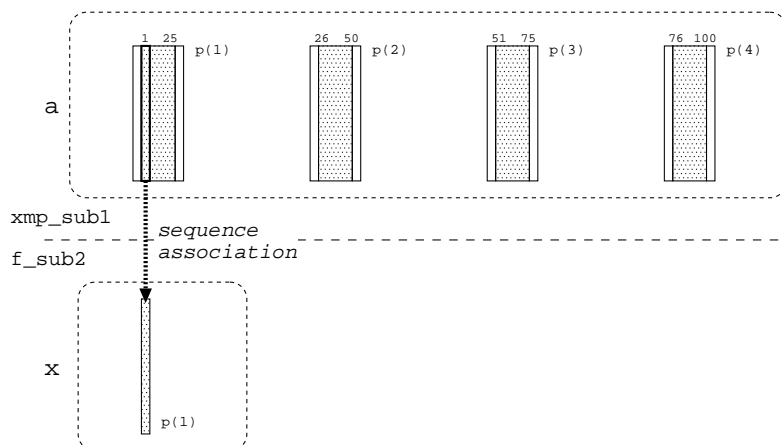

Figure 6.3: Sequence Association of a Section of a Global Data as an Actual Argument with a Local Dummy Argument

**Example 4** The actual argument  $a(1)$  is an element of the global data, and the dummy argument  $x$  is a local explicit-shape array. Sequence association is applied in this case, but only the node  $p(1)$  owns the element. Hence,  $f\_sub2$  is invoked only by  $p(1)$  (Figure 6.4).

|    | XcalableMP Fortran                                                                                                                                                                                                                                        |
|----|-----------------------------------------------------------------------------------------------------------------------------------------------------------------------------------------------------------------------------------------------------------|
| 5  | <pre> subroutine xmp_sub1 !\$xmp nodes p(4) !\$xmp template t(100) !\$xmp distribute t(block) onto p real a(100) !\$xmp align a(i) with t(i) !\$xmp shadow a(1:1) n = 100/4 !\$xmp task on p(1) call f_sub2(a(1),n) !\$xmp end task end subroutine </pre> |
| 10 | <pre> subroutine f_sub2(x,n) real x(n) ... </pre>                                                                                                                                                                                                         |

**Example 5** Even if either the global actual or dummy argument has a full shadow, the sequence association rule is the same in principle. Hence, the base address of the local section of  $a$  is passed between these subroutines on each node, and each the local section of  $x$  starts from the received address (Figure 6.5).

### 6.2.2 Descriptor Association of Global Data

When the actual argument is a global data and it is obvious from the interface of the invoked procedure that the corresponding dummy argument is neither an explicit-shape nor assumed-size array, the actual argument is *descriptor associated* with the dummy argument. According to the descriptor association rule, the dummy argument inherits its shape and storage from the actual argument.



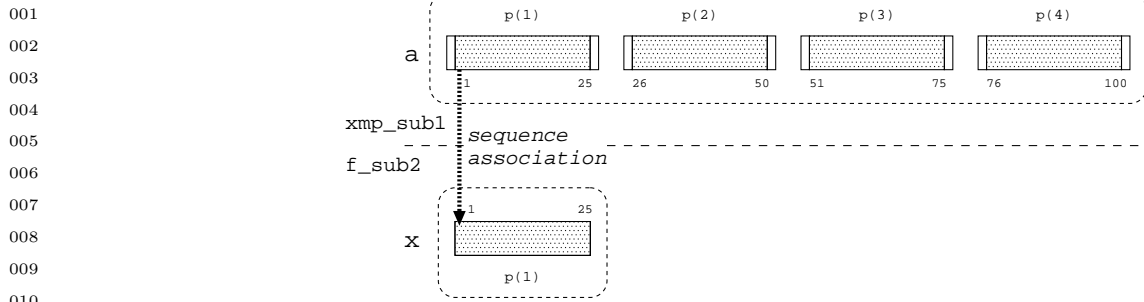

012 Figure 6.4: Sequence Association of an Element of a Global Data as an Actual Argument with  
 013 a Local Dummy Argument

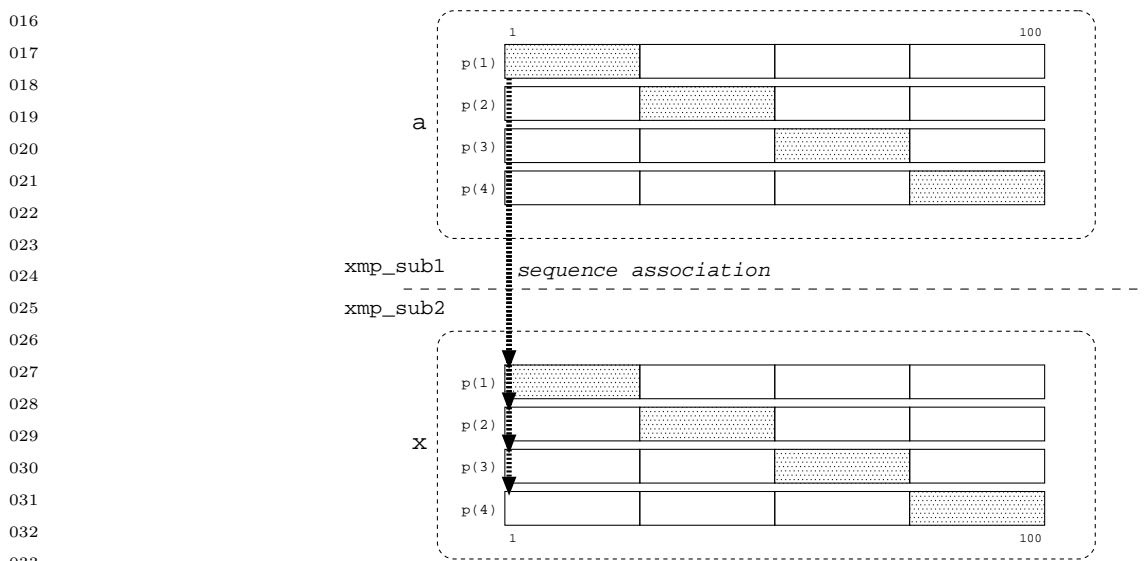

035 Figure 6.5: Sequence Association with a Global Dummy Argument that Has Full Shadow

036

037

038

039 **Implementation.** In order to implement the descriptor association, a global actual argument  
 040 is treated by the XcalableMP compiler:

- 041
- 042
- 043
- 044
- 045
- 046
- 047
- 048
- 049
- 050
- 051
- as if it were the *global-data descriptor* of the actual array, which is an internal data structure managed by the XcalableMP runtime system to hold information on a global data (see 7.1.1), if the dummy is a global data; or
  - as it is an array representing the local section of the actual array, which is to be processed by the backend Fortran compiler in the same manner as usual data, if the dummy is a local data.

052

053 For the first case, a global dummy is initialized at runtime with a copy of the global-data  
 054 descriptor received.

055

056 When an actual argument is descriptor associated with the dummy argument and their  
 057 mappings are not identical, the XcalableMP runtime system may detect and report the error.

## Examples

**Example 1** There is the explicit interface of the subroutine `xmp_sub2` specified by an interface block in the subroutine `xmp_sub1`, from which it is found that the dummy argument `x` is a global assumed-shape array. Therefore the global actual argument `a` is descriptor associated with the global dummy argument `x`.

It is the global-data descriptor of `a` that passed between these subroutines. The dummy argument `x` is initialized by the XcalableMP runtime system on the basis of the information extracted from the descriptor received (Figure 6.6).

|    |                                   |     |
|----|-----------------------------------|-----|
|    | XcalableMP Fortran                |     |
|    | subroutine xmp_sub1               | 001 |
|    | !\$xmp nodes p(4)                 | 002 |
|    | !\$xmp template t(100)            | 003 |
| 5  | !\$xmp distribute t(block) onto p | 004 |
|    | real a(100)                       | 005 |
|    | !\$xmp align a(i) with t(i)       | 006 |
|    | !\$xmp shadow a(1:1)              | 007 |
|    |                                   | 008 |
| 10 | interface                         | 009 |
|    | subroutine xmp_sub2(x)            | 010 |
|    | !\$xmp nodes p(4)                 | 011 |
|    | !\$xmp template t(100)            | 012 |
|    | !\$xmp distribute t(block) onto p | 013 |
| 15 | real x(:)                         | 014 |
|    | !\$xmp align x(i) with t(i)       | 015 |
|    | !\$xmp shadow a(1:1)              | 016 |
|    | end subroutine xmp_sub2           | 017 |
|    | end interface                     | 018 |
| 20 |                                   | 019 |
|    | call xmp_sub2(a)                  | 020 |
|    |                                   | 021 |
|    | end subroutine                    | 022 |
|    |                                   | 023 |
| 25 | subroutine xmp_sub2(x)            | 024 |
|    | !\$xmp nodes p(4)                 | 025 |
|    | !\$xmp template t(100)            | 026 |
|    | !\$xmp distribute t(block) onto p | 027 |
|    | real x(:)                         | 028 |
| 30 | !\$xmp align x(i) with t(i)       | 029 |
|    | !\$xmp shadow a(1:1)              | 030 |
|    | ...                               | 031 |
|    |                                   | 032 |
|    |                                   | 033 |
|    |                                   | 034 |
|    |                                   | 035 |
|    |                                   | 036 |
|    |                                   | 037 |
|    |                                   | 038 |
|    |                                   | 039 |
|    |                                   | 040 |
|    |                                   | 041 |
|    |                                   | 042 |
|    |                                   | 043 |
|    |                                   | 044 |
|    |                                   | 045 |
|    |                                   | 046 |
|    |                                   | 047 |
|    |                                   | 048 |
|    |                                   | 049 |

**Example 2** There is the explicit interface of the subroutine `f_sub2`, which is written in Fortran, specified by an interface block in the subroutine `xmp_sub1`, and the dummy argument `x` is a local (i.e. non-mapped) assumed-shape array. Therefore the global actual argument `a` is descriptor associated with the local dummy argument `x`.

The global actual argument is replaced with its local section by the XcalableMP compiler and the association of the local section with the dummy argument is to be processed by the backend Fortran compiler in the same manner as usual data (Figure 6.7).

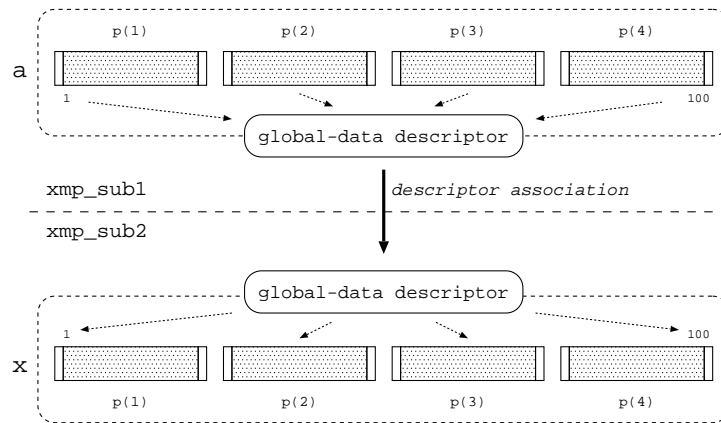

Figure 6.6: Descriptor Association with a Global Dummy Argument

```

019 XcalableMP Fortran
020 subroutine xmp_sub1
021
022 !$xmp nodes p(4)
023 !$xmp template t(100)
024 5 !$xmp distribute t(block) onto p
025 real a(100)
026 !$xmp align a(i) with t(i)
027 !$xmp shadow a(1:1)
028
029
030 10 interface
031 subroutine f_sub2(x)
032 real x(:)
033 end subroutine f_sub2
034 end interface
035
036 15 call f_sub2(a)
037
038
039 end subroutine
040
041 Fortran
042 subroutine f_sub2(x)
043 real x(:)
044 ...
045
046
047
048
049
050
051
052
053
054
055
056
057

```

### 6.3 Argument Passing Mechanism in XcalableMP C

When an actual argument is a global data, it is passed by the address of its local section. When a dummy argument is a global data, an address is received and used as the base address of each of its local section.

**Implementation.** The name of a global data appearing as an actual argument is treated by the XcalableMP compiler as the pointer to the first element of its local section on each node.

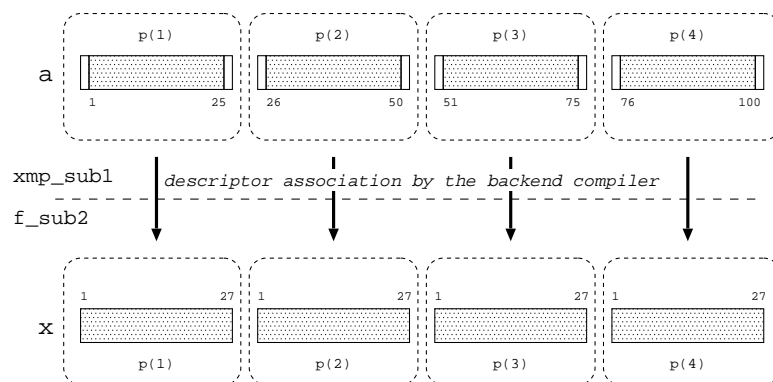

Figure 6.7: Descriptor Association with a Local Dummy Argument

On a node onto which no part of the global data is mapped, the pointer is set to an unspecified value (e.g. null). Note that an element of a global data in the actual argument list is treated in the same manner as those in other usual statements because an array element is passed by value as in C.

The name of a global data appearing as a dummy argument is treated by the XcalableMP compiler as the pointer to the first element of its local section on each node. As a result, it is initialized at runtime so as to be composed of the local sections on the executing nodes.

Such implementation implies that in many cases, in order to pass properly a global actual argument to the corresponding global dummy argument, their mappings (including their shadow attributes) must be identical.

## Examples

**Example 1** The global actual argument `a` is treated by the XcalableMP compiler as the pointer to the first element of its local section, which is passed to the callee, on each node.

The global dummy argument `x` is initialized so that each of its local section starts from the address held by the received pointer (Figure 6.8).

```

XcalableMP C
void xmp_func1()
{
 #pragma xmp nodes p(4)
 #pragma xmp template t(0:99)
5 #pragma xmp distribute t(block) onto p
 float a[100];
 #pragma xmp align a[i] with t(i)
 #pragma xmp shadow a[1:1]

10 xmp_func2(a);
}

void xmp_func2(float x[100])
{
15 #pragma xmp nodes p(4)
 #pragma xmp template t(0:99)
 #pragma xmp distribute t(block) onto p

```

```

001 #pragma xmp align x[i] with t(i)
002 #pragma xmp shadow a[1:1]
003
004 20 ...

```

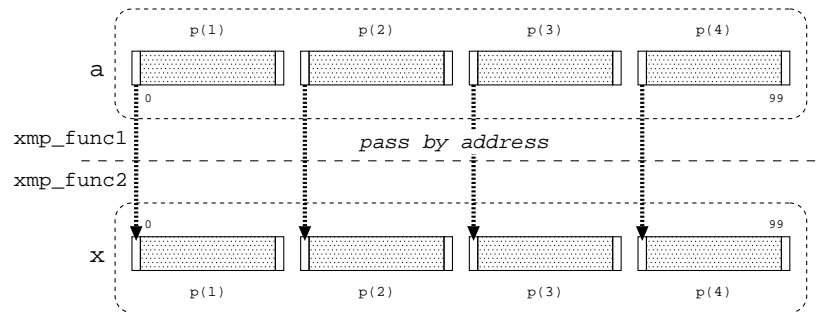

Figure 6.8: Passing to a Global Dummy Argument

**Example 2** The global actual argument `a` is treated by the XcalableMP compiler as the pointer to the first element of its local section, which is passed to the callee, on each node.

The local dummy argument `x` on each node starts from the address held by the received pointer (Figure 6.9).

```

026 XcalableMP C
027
028 void xmp_func1()
029 {
030 #pragma xmp nodes p(4)
031 #pragma xmp template t(0:99)
032 #pragma xmp distribute t(block) onto p
033 float a[100];
034 #pragma xmp align a[i] with t(i)
035 #pragma xmp shadow a[1:1]
036
037 10 c_func2(a);
038 }
039

```

```

040 C
041
042 void c_func2(float x[27])
043 {
044 ...

```

**Example 3** The actual argument `a[0]` is an element of the global data and the dummy argument `x` is a scalar, in which case the normal argument-passing rule of C for variables of a basic type (i.e. “pass-by-value”) is applied. However, only the node `p(1)` owns the element. Hence, `c_func2` is invoked only by `p(1)` (Figure 6.10).

```

052 XcalableMP C
053
054 void xmp_func1()
055 {
056 #pragma xmp nodes p(4)
057 #pragma xmp template t(0:99)
058 #pragma xmp distribute t(block) onto p

```

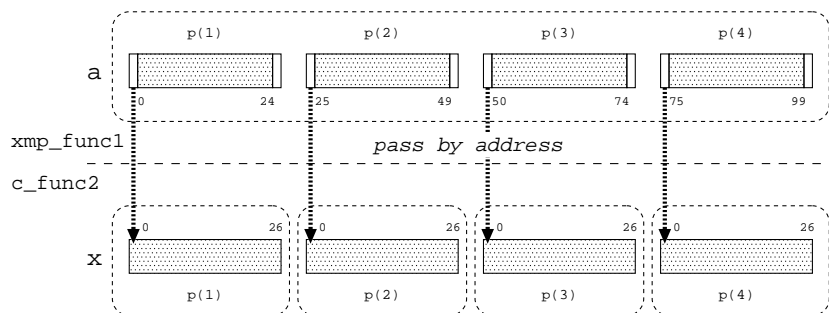

Figure 6.9: Passing to a Local Dummy Argument

```

float a[100];
#pragma xmp align a[i] with t(i)
#pragma xmp shadow a[1:1]
10 #pragma xmp task on p(1)
 c_func2(a[0]);
}

```

C

```

void c_func2(float x)
{
 ...
}

```

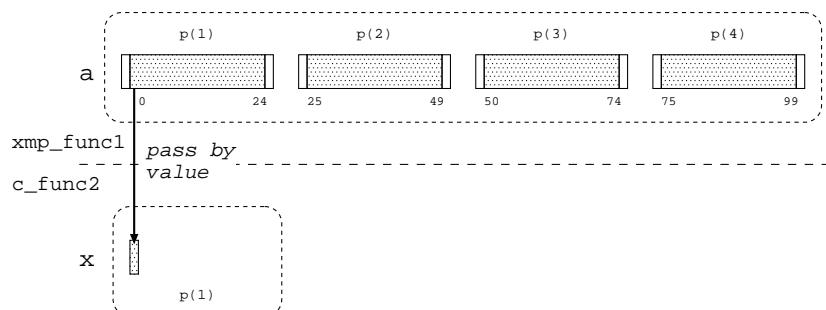

Figure 6.10: Passing an Element of a Global Data as an Actual Argument to a Local Dummy Argument

001  
002  
003  
004  
005  
006  
007  
008  
009  
010  
011  
012  
013  
014  
015  
016  
017  
018  
019  
020  
021  
022  
023  
024  
025  
026  
027  
028  
029  
030  
031  
032  
033  
034  
035  
036  
037  
038  
039  
040  
041  
042  
043  
044  
045  
046  
047  
048  
049  
050  
051  
052  
053  
054  
055  
056  
057

001  
002  
003  
004  
005  
006  
007  
008  
009  
010  
011  
012  
013  
014  
015  
016  
017  
018  
019  
020  
021  
022  
023  
024  
025  
026  
027  
028  
029  
030  
031  
032  
033  
034  
035  
036  
037  
038  
039  
040  
041  
042  
043  
044  
045  
046  
047  
048  
049  
050  
051  
052  
053  
054  
055  
056  
057

## Chapter 7

# Intrinsic and Library Procedures

This specification defines various procedures for system inquiry, synchronization, computations, etc. The procedures are provided as intrinsic procedures in XcalableMP Fortran and library procedures in XcalableMP C.

## 7.1 [F] Intrinsic Functions

### 7.1.1 `xmp_desc_of`

#### Format

[F] `type(xmp_desc) xmp_desc_of(xmp_entity)`

Note that `xmp_desc_of` is an intrinsic function in XcalableMP Fortran or a built-in operator in XcalableMP C. For the `xmp_desc_of` operator, refer to section 5.6.

#### Synopsis

`xmp_desc_of` returns a descriptor to retrieve informations of the specified global array, template, or node array. The resulting descriptor can be used as an input argument of mapping inquiry functions.

The type of the descriptor, `type(xmp_desc)`, is implementation-dependent, and defined in a Fortran module named `xmp_lib` or a Fortran include file named `xmp_lib.h`.

#### Arguments

The argument or operand `xmp_entity` is the name of either a global array, a template or a node array.

## 7.2 System Inquiry Functions

- `xmp_all_node_num`
- `xmp_all_num_nodes`
- `xmp_node_num`
- `xmp_num_nodes`
- `xmp_wtime`
- `xmp_wtick`



### 7.2.1 xmp\_all\_node\_num

#### Format

```
[F] integer function xmp_all_node_num()
[C] int xmp_all_node_num(void)
```

#### Synopsis

The `xmp_all_node_num` routine returns the node number, within the primary node set, of the node that calls `xmp_all_node_num`.

#### Arguments

none.

### 7.2.2 xmp\_all\_num\_nodes

#### Format

```
[F] integer function xmp_all_num_nodes()
[C] int xmp_all_num_nodes(void)
```

#### Synopsis

The `xmp_all_num_nodes` routine returns the number of nodes in the entire node set.

#### Arguments

none.

### 7.2.3 xmp\_node\_num

#### Format

```
[F] integer function xmp_node_num()
[C] int xmp_node_num(void)
```

#### Synopsis

The `xmp_node_num` routine returns the node number, within the current executing node set, of the node that calls `xmp_node_num`.

#### Arguments

none.

### 7.2.4 xmp\_num\_nodes

#### Format

```
[F] integer function xmp_num_nodes()
[C] int xmp_num_nodes(void)
```

#### Synopsis

The `xmp_num_nodes` routine returns the number of the executing nodes.

**Arguments**

none.

**7.2.5 xmp\_wtime****Format**

```
[F] double precision function xmp_wtime()
[C] double xmp_wtime(void)
```

**Synopsis**

The `xmp_wtime` routine returns elapsed wall clock time in seconds since some time in the past. The “time in the past” is guaranteed not to change during the life of the process. There is no requirement that different nodes return “the same time.”

**Arguments**

none.

**7.2.6 xmp\_wtick****Format**

```
[F] double precision function xmp_wtick()
[C] double xmp_wtick(void)
```

**Synopsis**

The `xmp_wtick` routine returns the resolution of the timer used by `xmp_wtime`. It returns a double precision value equal to the number of seconds between successive clock ticks.

**Arguments**

none.

**7.3 Synchronization Functions****7.3.1 xmp\_test\_async**

```
[F] logical function xmp_test_async(async_id)
 integer async_id

[C] int xmp_test_async(int async_id)
```

**Synopsis**

The `xmp_test_async` routine returns `.true.`, in XcalableMP Fortran, or `1`, in XcalableMP C, if an asynchronous communication specified by the argument `async_id` is complete; otherwise, it returns `.false.` or `0`.

## Arguments

The argument `async_id` is an integer expression that specifies an asynchronous communication initiated by a global communication construct with the `async` clause.

## 7.4 Memory Allocation Functions

### 7.4.1 [C] `xmp_malloc`

```
void* xmp_malloc(xmp_desc_t d, size_t size)
```

#### Synopsis

The `xmp_malloc` routine allocates a storage for the local section of a one-dimensional global array of size `size` that is associated with the descriptor specified by `d`, and returns the pointer to it on each node. For an example of `xmp_malloc`, refer to section 5.5.

#### Arguments

- `d` is the descriptor associated with a pointer to the one-dimensional global array to be allocated.
- `size` is the size of the global array to be allocated.

## 7.5 Mapping Inquiry Functions

All mapping inquiry functions are specified as integer functions. These functions return zero on success and an implementation-dependent negative integer value on failure.

### 7.5.1 `xmp_nodes_ndims`

#### Format

```
[F] integer function xmp_nodes_ndims(d, ndims)
 type(xmp_desc) d
 integer ndims
[C] int xmp_nodes_ndims(xmp_desc_t d, int *ndims)
```

#### Synopsis

The `xmp_nodes_ndims` function provides the rank of the target node array.

#### Input Arguments

- `d` is a descriptor of a node array.

#### Output Arguments

- `ndims` is the rank of the node array specified by `d`.

## 7.5.2 xmp\_nodes\_index

## Format

|     |                  |                                                    |     |
|-----|------------------|----------------------------------------------------|-----|
| [F] | integer function | xmp_nodes_index(d, dim, index)                     | 001 |
|     | type(xmp_desc)   | d                                                  | 002 |
|     | integer          | dim                                                | 003 |
|     | integer          | index                                              | 004 |
| [C] | int              | xmp_nodes_index(xmp_desc_t d, int dim, int *index) | 005 |

## Synopsis

The `xmp_nodes_index` function provides the indices of the executing node in the target node array.

## Input Arguments

- `d` is a descriptor of a node array.
- `dim` is the target dimension of the node array.

## Output Arguments

- `index` is an index of the target dimension of the node array specified by `d`.

## 7.5.3 xmp\_nodes\_size

## Format

|     |                  |                                                  |     |
|-----|------------------|--------------------------------------------------|-----|
| [F] | integer function | xmp_nodes_size(d, dim, size)                     | 001 |
|     | type(xmp_desc)   | d                                                | 002 |
|     | integer          | dim                                              | 003 |
|     | integer          | size                                             | 004 |
| [C] | int              | xmp_nodes_size(xmp_desc_t d, int dim, int *size) | 005 |

## Synopsis

The `xmp_nodes_size` function provides the size of each dimension of the target node array.

## Input Arguments

- `d` is a descriptor of a node array.
- `dim` is the target dimension of the node array.

## Output Arguments

- `size` is an extent of the target dimension of the node array specified by `d`.

### 7.5.4 xmp\_nodes\_attr

#### Format

```

001 [F] integer function xmp_nodes_attr(d, attr)
002 type(xmp_desc) d
003 integer attr
004 [C] int xmp_nodes_attr(xmp_desc_t d, int *attr)

```

#### Synopsis

The `xmp_nodes_attr` function provides the attribute of the target node array. The output value of the argument `attr` is one of:

```

015 XMP_ENTIRE_NODES (Entire nodes)
016 XMP_EXECUTING_NODES (Executing nodes)
017 XMP_PRIMARY_NODES (Primary nodes)
018 XMP_EQUIVALENCE_NODES (Equivalence nodes)

```

These are named constants defined in module `xmp_lib` and in include file `xmp_lib.h` in XcalableMP Fortran, and symbolic constants defined in header file `xmp.h` in XcalableMP C.

#### Input Arguments

- `d` is a descriptor of a node array.

#### Output Arguments

- `attr` is an attribute of the target node array specified by `d`.

### 7.5.5 xmp\_nodes\_equiv

#### Format

```

035 [F] integer function xmp_nodes_equiv(d, dn, lb, ub, st)
036 type(xmp_desc) d
037 type(xmp_desc) dn
038 integer lb(*)
039 integer ub(*)
040 integer st(*)
041 [C] int xmp_nodes_equiv(xmp_desc_t d, xmp_desc_t *dn,
042 int lb[], int ub[], int st[])

```

#### Synopsis

The `xmp_nodes_equiv` function provides the descriptor of a node array and a subscript list that represent a node set that is assigned to the target node array in the `nodes` directive. This function returns with failure when the target node array is not declared as equivalenced.

#### Input Arguments

- `d` is a descriptor of a node array.

**Output Arguments**

- **dn** is the descriptor of the referenced node array if the target node array is declared as equivalenced; otherwise **dn** is set to undefined.
- **lb** is a one-dimensional integer array the extent of which must be more than or equal to the rank of the referenced node array. The *i*-th element of **lb** is set to the lower bound of the *i*-th subscript of the node reference unless it is “\*”, or to undefined otherwise.
- **ub** is a one-dimensional integer array the extent of which must be more than or equal to the rank of the referenced node array. The *i*-th element of **ub** is set to the upper bound of the *i*-th subscript of the node reference unless it is “\*”, or to undefined otherwise.
- **st** is a one-dimensional integer array the extent of which must be more than or equal to the rank of the referenced node array. The *i*-th element of **st** is set to the stride of the *i*-th subscript of the node reference unless it is “\*”, or to zero otherwise.

**7.5.6 xmp\_template\_fixed****Format**

```
[F] integer function xmp_template_fixed(d, fixed)
 type(xmp_desc) d
 logical fixed
[C] int xmp_template_fixed(xmp_desc_t d, int *fixed)
```

**Synopsis**

The `xmp_template_fixed` function provides the logical value which shows whether the template is fixed or not.

**Input Arguments**

- **d** is a descriptor of a template.

**Output Arguments**

- **fixed** is set to true in XcalableMP Fortran and an implementation-dependent non-zero integer value in XcalableMP C if the template specified by **d** is fixed; otherwise to false in XcalableMP Fortran and zero in XcalableMP C.

**7.5.7 xmp\_template\_ndims****Format**

```
[F] integer function xmp_template_ndims(d, ndims)
 type(xmp_desc) d
 integer ndims
[C] int xmp_template_ndims(xmp_desc_t d, int *ndims)
```

**Synopsis**

The `xmp_template_ndims` function provides the rank of the target template.

**Input Arguments**

- `d` is a descriptor of a template.

**Output Arguments**

- `ndims` is the rank of the template specified by `d`.

**7.5.8 xmp\_template\_lbound****Format**

```
[F] integer function xmp_template_lbound(d, dim, lbound)
 type(xmp_desc) d
 integer dim
 integer lbound
[C] int xmp_template_lbound(xmp_desc_t d, int dim, int *lbound)
```

**Synopsis**

The `xmp_template_lbound` function provides the lower bound of each dimension of the template. This function returns with failure when the lower bound is not fixed.

**Input Arguments**

- `d` is a descriptor of a template.
- `dim` is the target dimension of the template.

**Output Arguments**

- `lbound` is the lower bound of the target dimension of the template specified by `d`. When the lower bound is not fixed, it is set to undefined.

**7.5.9 xmp\_template\_ubound****Format**

```
[F] integer function xmp_template_ubound(d, dim, ubound)
 type(xmp_desc) d
 integer dim
 integer ubound
[C] int xmp_template_ubound(xmp_desc_t d, int dim, int *ubound)
```

**Synopsis**

The `xmp_template_ubound` function provides the upper bound of each dimension of the template. This function returns with failure when the upper bound is not fixed.

**Input Arguments**

- `d` is a descriptor of a template.
- `dim` is the target dimension of the template.

**Output Arguments**

- `ubound` is a upper bound of the target dimension of the template specified by `d`. When the upper bound is not fixed, it is set undefined.

**7.5.10 xmp\_dist\_format****Format**

```
[F] integer function xmp_dist_format(d, dim, format)
 type(xmp_desc) d
 integer dim
 integer format
[C] int xmp_dist_format(xmp_desc_t d, int dim, int *format)
```

**Synopsis**

The `xmp_dist_format` function provides the distribution format of a dimension of a template. The output value of the argument `format` is one of:

```
XMP_NOT_DISTRIBUTED (not distributed)
XMP_BLOCK (block distribution)
XMP_CYCLIC (cyclic distribution)
XMP_GBLOCK (gblock distribution)
```

These symbolic constants are defined in “`xmp.h`”.

**Input Arguments**

- `d` is a descriptor of a template.
- `dim` is the target dimension of the template.

**Output Arguments**

- `format` is a distribution format of the target dimension of the template specified by `d`.

**7.5.11 xmp\_dist\_blocksize****Format**

```
[F] integer function xmp_dist_blocksize(d, dim, blocksize)
 type(xmp_desc) d
 integer dim
 integer blocksize
[C] int xmp_dist_blocksize(xmp_desc_t d, int dim, int *blocksize)
```

**Synopsis**

The `xmp_dist_blocksize` function provides the block width of a dimension of a template.

**Input Arguments**

- `d` is a descriptor of a template.
- `dim` is the target dimension of the template.



**Output Arguments**

- `blocksize` is the block width of the target dimension of the template specified by `d`.

**7.5.12 xmp\_dist\_gblockmap****Format**

```
[F] integer function xmp_dist_gblockmap(d, dim, map)
 type(xmp_desc) d
 integer dim
 integer map(N)
[C] int xmp_dist_gblockmap(xmp_desc_t d, int dim, int map[])
```

**Synopsis**

The `xmp_dist_gblockmap` function provides the mapping array of the `gblock` distribution.

When `dim` dimension of the global array is distributed by `gblock` and its mapping array is fixed, this function returns zero; otherwise it returns an implementation-dependent negative integer value.

**Input Arguments**

- `d` is a descriptor of a template.
- `dim` is the target dimension of the template.

**Output Arguments**

- `map` is a one-dimensional integer array the extent of which is more than the size of the corresponding dimension of the node array onto which the template is distributed.

The *i*-th element of `map` is set to the value of the *i*-th element of the target mapping array.

**7.5.13 xmp\_dist\_nodes****Format**

```
[F] integer function xmp_dist_nodes(d, dn)
 type(xmp_desc) d
 type(xmp_desc) dn
[C] int xmp_dist_nodes(xmp_desc_t d, xmp_desc_t *dn)
```

**Synopsis**

The `xmp_dist_nodes` function provides the descriptor of the node array onto which a template is distributed.

**Input Arguments**

- `d` is a descriptor of a template.

**Output Arguments**

- `dn` is the descriptor of the node array.

**7.5.14 xmp\_dist\_axis****Format**

```

[F] integer function xmp_dist_axis(d, dim, axis)
 type(xmp_desc) d
 integer dim
 integer axis
[C] int xmp_dist_axis(xmp_desc_t d, int dim, int *axis)

```

**Synopsis**

The `xmp_dist_axis` function provides the dimension of the node array onto which a dimension of a template is distributed. This function returns with failure when the dimension of the template is not distributed.

**Input Arguments**

- `d` is a descriptor of a template.
- `dim` is the target dimension of the template.

**Output Arguments**

- `axis` is a dimension of the node array onto which the target dimension of the template specified by `d` is distributed. When the dimension of the template is not distributed, it is set to undefined.

**7.5.15 xmp\_align\_axis****Format**

```

[F] integer function xmp_align_axis(d, dim, axis)
 type(xmp_desc) d
 integer dim
 integer axis
[C] int xmp_align_axis(xmp_desc_t d, int dim, int *axis)

```

**Synopsis**

The `xmp_align_axis` function provides the dimension of the template with which a dimension of a global array is aligned. This function returns with failure when the dimension of the global array is not aligned.

**Input Arguments**

- `d` is a descriptor of a global array.
- `dim` is the target dimension of the global array.

**Output Arguments**

- `axis` is the dimension of the template with which the target dimension of the global array specified by `d` is aligned. When the dimension of the global array is not aligned, or collapsed, it is set to undefined.

### 7.5.16 xmp\_align\_offset

#### Format

```
[F] integer function xmp_align_offset(d, dim, offset)
 type(xmp_desc) d
 integer dim
 integer offset
[C] int xmp_align_offset(xmp_desc_t d, int dim, int *offset)
```

#### Synopsis

The `xmp_align_offset` function provides the align offset for a dimension of a global array. This function returns with failure when there is no offset.

#### Input Arguments

- `d` is a descriptor of a global array.
- `dim` is the target dimension of the global array.

#### Output Arguments

- `offset` is the align offset for the target dimension of the global array specified by `d`. When there is no offset, it is set to undefined.

### 7.5.17 xmp\_align\_replicated

#### Format

```
[F] integer function xmp_align_replicated(d, dim, replicated)
 type(xmp_desc) d
 integer dim
 logical replicated
[C] int xmp_align_replicated(xmp_desc_t d, int dim, int *replicated)
```

#### Synopsis

The `xmp_align_replicated` function provides the logical value which shows whether the dimension of the template with which a global array is aligned is replicated or not.

#### Input Arguments

- `d` is a descriptor of a global array.
- `dim` is the target dimension of the template with which the global array is aligned.

#### Output Arguments

- `replicated` is a logical scalar, which is set to true if the dimension of the template is replicated.

## 7.5.18 xmp\_align\_template

**Format**

```

[F] integer function xmp_align_template(d, dt)
 type(xmp_desc) d
 type(xmp_desc) dt
[C] int xmp_align_template(xmp_desc_t d, xmp_desc_t *dn)

```

**Synopsis**

The `xmp_align_template` function provides the descriptor of the template with which a global array is aligned.

**Input Arguments**

- `d` is a descriptor of a global array.

**Output Arguments**

- `dt` is the descriptor of the template.

## 7.5.19 xmp\_array\_ndims

**Format**

```

[F] integer function xmp_array_ndims(d, ndims)
 type(xmp_desc) d
 integer ndims
[C] int xmp_array_ndims(xmp_desc_t d, int *ndims)

```

**Synopsis**

The `xmp_array_ndims` function provides the rank of a global array.

**Input Arguments**

- `d` is a descriptor of a global array.

**Output Arguments**

- `ndims` is the rank of the global array specified by `d`.

## 7.5.20 xmp\_array\_lshadow

**Format**

```

[F] integer function xmp_array_lshadow(d, dim, lshadow)
 type(xmp_desc) d
 integer dim
 integer lshadow
[C] int xmp_array_lshadow(xmp_desc_t d, int dim, int *lshadow)

```

**Synopsis**

The `xmp_array_lshadow` function provides the size of lower shadow of a dimension of a global array.

**Input Arguments**

- `d` is a descriptor of a global array.
- `dim` is the target dimension of the global array.

**Output Arguments**

- `lshadow` is the size of the lower shadow of the target dimension of the global array specified by `d`.

**7.5.21 xmp\_array\_ushadow****Format**

```
[F] integer function xmp_array_ushadow(d, dim, ushadow)
 type(xmp_desc) d
 integer dim
 integer ushadow
[C] int xmp_array_ushadow(xmp_desc_t d, int dim, int *ushadow)
```

**Synopsis**

The `xmp_array_ushadow` function provides the size of upper shadow of a dimension of a global array.

**Input Arguments**

- `d` is a descriptor of a global array.
- `dim` is the target dimension of the global array.

**Output Arguments**

- `ushadow` is the size of the upper shadow of the target dimension of the global array specified by `d`.

**7.5.22 xmp\_array\_lbound****Format**

```
[F] integer function xmp_array_lbound(d, dim, lbound)
 type(xmp_desc) d
 integer dim
 integer lbound
[C] int xmp_array_lbound(xmp_desc_t d, int dim, int *lbound)
```

**Synopsis**

The `xmp_array_lbound` function provides the lower bound of a dimension of a global array. This function returns with failure when the lower bound is not fixed.

**Input Arguments**

- `d` is a descriptor of a global array.
- `dim` is the target dimension of the global array.

**Output Arguments**

- `lbound` is the lower bound of the target dimension of the global array specified by `d`. When the lower bound is not fixed, it is set to undefined.

**7.5.23 xmp\_array\_ubound****Format**

|     |                             |                                                                   |
|-----|-----------------------------|-------------------------------------------------------------------|
| [F] | integer function            | <code>xmp_array_ubound(d, dim, ubound)</code>                     |
|     | <code>type(xmp_desc)</code> | <code>d</code>                                                    |
|     | integer                     | <code>dim</code>                                                  |
|     | integer                     | <code>ubound</code>                                               |
| [C] | int                         | <code>xmp_array_ubound(xmp_desc_t d, int dim, int *ubound)</code> |

**Synopsis**

The `xmp_array_ubound` function provides the upper bound of a dimension of a global array. This function returns with failure when the upper bound is not fixed.

**Input Arguments**

- `d` is a descriptor of a global array.
- `dim` is the target dimension of the global array.

**Output Arguments**

- `ubound` is the upper bound of the target dimension of the global array specified by `d`. When the upper bound is not fixed, it is set to undefined.

**7.6 [F] Array Intrinsic Functions of the Base Language**

The array intrinsic functions of the base language Fortran are classified into three classes: *inquiry*, *elemental*, and *transformational*.

This section specifies how these functions work in the XMP/F programs when a global array appears as an argument.

- Inquiry functions

The inquiry functions with a global array or its subobject being an argument are regarded as inquiries about the global array and return its “global” properties, as if it were not distributed.

- Elemental functions

The result of the elemental functions with a global array or its subobject being an argument is of the same shape and mapping as the argument. Note that such a reference of these elemental functions is in effect limited to be in the `array` construct.

- Transformational functions

It is not defined how the transformational functions with a global array or its subobject being an argument work. A processor shall detect such a reference of these functions and issue a warning message for it. Some intrinsic transformational subroutines are defined in section 7.8 as alternatives to these transformational functions.

## 7.7 [C] Built-in Elemental Functions

Some built-in elemental functions that could operate each element of array arguments are defined in XcalableMP C. Such a built-in function accepts one or more array sections as its arguments and returns an array-valued result of the same shape and mapping as the argument. The values of the elements of the result are the same as would have been obtained if the scalar function of the C standard library had been applied separately to the corresponding elements of each array argument.

These functions can appear in the right-hand side of an array assignment statement, and should be preceded by the `array` directive if the array section is distributed.

Table 7.1 shows the list of built-in elemental functions in XcalableMP C. Their elementwise behavior is the same as those of the corresponding functions in the C standard library.

Table 7.1: Built-in Elemental Functions in XcalableMP C (The first line means the element type of their argument(s) and return value.)

| double | float  | long double |
|--------|--------|-------------|
| acos   | acosf  | acosl       |
| asin   | asinf  | asinl       |
| atan   | atanf  | atanl       |
| atan2  | atan2f | atan2l      |
| cos    | cosf   | cosl        |
| sin    | sinf   | sinl        |
| tan    | tanf   | tanl        |
| cosh   | coshf  | coshl       |
| sinh   | sinhf  | sinhl       |
| tanh   | tanhf  | tanhl       |
| exp    | expf   | expl        |
| frexp  | frexpf | frexpl      |
| ldexp  | ldexpf | ldexpl      |
| log    | logf   | logl        |
| log10  | log10f | log10l      |
| fabs   | fabsf  | fabsl       |
| pow    | powf   | powl        |
| sqrt   | sqrtf  | sqrtl       |
| ceil   | ceilf  | ceill       |
| floor  | floorf | floorl      |
| fmod   | fmodf  | fmodl       |

## 7.8 Intrinsic/Built-in Transformational Procedures

Some intrinsic/built-in transformational procedures are defined for non-elemental operation of arrays.

### 7.8.1 xmp\_scatter

#### Format

[F]            xmp\_scatter(x, a, idx1, idx2, ...)  
[C] void xmp\_scatter(x, a, idx1, idx2, ...)

#### Synopsis

The xmp\_scatter subroutine ...

#### Input Arguments

- a is ...
- idx1 is ...

#### Output Arguments

- x is ...

### 7.8.2 xmp\_gather

#### Format

[F]            xmp\_gather(x, a, idx1, idx2, ...)  
[C] void xmp\_gather(x, a, idx1, idx2, ...)

#### Synopsis

The xmp\_gather subroutine ...

#### Input Arguments

- a is ...
- idx1 is ...

#### Output Arguments

- x is ...

### 7.8.3 xmp\_pack

#### Format

[F]            xmp\_pack(v, a, mask)  
[C] void xmp\_pack(v, a, mask)

#### Synopsis

The xmp\_pack subroutine ...

001  
002  
003  
004  
005  
006  
007  
008  
009  
010  
011  
012  
013  
014  
015  
016  
017  
018  
019  
020  
021  
022  
023  
024  
025  
026  
027  
028  
029  
030  
031  
032  
033  
034  
035  
036  
037  
038  
039  
040  
041  
042  
043  
044  
045  
046  
047  
048  
049  
050  
051  
052  
053  
054  
055  
056  
057



**Input Arguments**

- a is ...
- mask is ...

**Output Arguments**

- v is ...

**7.8.4 xmp\_unpack****Format**

[F]            xmp\_unpack(v, a, mask)  
[C] void    xmp\_unpack(v, a, mask)

**Synopsis**

The xmp\_unpack subroutine ...

**Input Arguments**

- a is ...
- mask is ...

**Output Arguments**

- v is ...

**7.8.5 xmp\_transpose****Format**

[F]            xmp\_transpose(x, a)  
[C] void    xmp\_transpose(x, a)

**Synopsis**

The xmp\_transpose subroutine ...

**Input Arguments**

- a is ...

**Output Arguments**

- x is ...

**7.8.6 xmp\_matmul****Format**

[F]            xmp\_matmul(x, a, b)  
[C] void    xmp\_matmul(x, a, b)

**Synopsis**

The `xmp_matmul` subroutine ...

**Input Arguments**

- `a` is ...
- `b` is ...

**Output Arguments**

- `x` is ...

**7.8.7 `xmp_sort_up`****Format**

[F]            `xmp_sort_up(x, a)`  
[C]   `void xmp_sort_up(x, a)`

**Synopsis**

The `xmp_sort_up` subroutine ...

**Input Arguments**

- `a` is ...

**Output Arguments**

- `x` is ...

**7.8.8 `xmp_sort_down`****Format**

[F]            `xmp_sort_down(x, a)`  
[C]   `void xmp_sort_down(x, a)`

**Synopsis**

The `xmp_sort_down` subroutine ...

**Input Arguments**

- `a` is ...

**Output Arguments**

- `x` is ...

001  
002  
003  
004  
005  
006  
007  
008  
009  
010  
011  
012  
013  
014  
015  
016  
017  
018  
019  
020  
021  
022  
023  
024  
025  
026  
027  
028  
029  
030  
031  
032  
033  
034  
035  
036  
037  
038  
039  
040  
041  
042  
043  
044  
045  
046  
047  
048  
049  
050  
051  
052  
053  
054  
055  
056  
057

# Bibliography

- [1] OpenMP Architecture Review Board, “OpenMP Application Program Interface Version 3.1”, <http://www.openmp.org/mp-documents/OpenMP3.1.pdf> (2011).
- [2] High Performance Fortran Forum, “High Performance Fortran Language Specification Version 2.0”, <http://hpff.rice.edu/versions/hpf2/hpf-v20.pdf> (1997).
- [3] Message Passing Interface Forum, “MPI: A Message-Passing Interface Standard Version 2.2”, <http://www.mpi-forum.org/docs/mpi-2.2/mpi22-report.pdf> (2009).
- [4] Japan Association of High Performance Fortran, “HPF/JA Language Specification”, <http://www.hpfpc.org/jahpf/spec/hpfja-v10-eng.pdf> (1999).
- [5] Yuanyuan Zhang, Hidetoshi Iwashita, Kuninori Ishii, Masanori Kaneko, Tomotake Nakamura, and Kohichiro Hotta, “Hybrid Parallel Programming on SMP Clusters Using XP-Fortran and OpenMP”, Proceedings of the International Workshop on OpenMP (IWOMP 2010), Vol. 6132 of Lecture Notes in Computer Science, pp. 133–148, Springer (2010).
- [6] Hidetoshi Iwashita, Naoki Sueyasu, Sachio Kamiya, and Matthijs van Waveren, “VPP Fortran and the design of HPF/JA extensions”, Concurrency and Computation — Practice & Experience, Vol. 14, No. 8–9, pp. 575–588, Wiley (2002).
- [7] Jinpil Lee, Mitsuhsa Sato, and Taisuke Boku, “OpenMPD: A Directive-Based Data Parallel Language Extension for Distributed Memory Systems”, Proceedings of the 2008 International Conference on Parallel Processing, pp. 121-128 (2008).

# Appendix A

## Programming Interface for MPI

This chapter describes the programming interface for MPI, which are widely used for parallel programming for cluster computing. Users can introduce MPI functions to XcalableMP using the interface.

XcalableMP provides the following user API functions to mix MPI functions with XcalableMP.

- `xmp_get_mpi_comm`
- `xmp_init_mpi`
- `xmp_finalize_mpi`

### A.1 `xmp_get_mpi_comm`

#### Format

[F] integer function `xmp_get_mpi_comm()`  
[C] MPI\_Comm `xmp_get_mpi_comm(void)`

#### Synopsis

`xmp_get_mpi_comm` returns the handle of the communicator associated with the executing node set.

#### Arguments

none.

### A.2 `xmp_init_mpi`

#### Format

[F] `xmp_init_mpi()`  
[C] void `xmp_init_mpi(int *argc, char ***argv)`

#### Synopsis

`xmp_init_mpi` initializes the MPI execution environment.

001  
002  
003  
004  
005  
006  
007  
008  
009  
010  
011  
012  
013  
014  
015  
016  
017  
018  
019  
020  
021  
022  
023  
024  
025  
026  
027  
028  
029  
030  
031  
032  
033  
034  
035  
036  
037  
038  
039  
040  
041  
042  
043  
044  
045  
046  
047  
048  
049  
050  
051  
052  
053  
054  
055  
056  
057

## Arguments

In XcalableMP C, the command-line arguments `argc` and `argv` should be given to `xmp_init_mpi`.

## A.3 `xmp_finalize_mpi`

### Format

```
[F] xmp_finalize_mpi()
[C] void xmp_finalize_mpi(void)
```

### Synopsis

`xmp_finalize_mpi` terminates the MPI execution environment.

### Arguments

none.

### Example

```

----- XcalableMP C -----
#include <stdio.h>
#include "mpi.h"
#include "xmp.h"

5 #pragma xmp nodes p(4)

int main(int argc, char *argv[]) {
 xmp_init_mpi(&argc, &argv)

 int rank, size;
 MPI_Comm_rank(MPI_COMM_WORLD, &rank);
 MPI_Comm_size(MPI_COMM_WORLD, &size);

 #pragma xmp task on p(2:3)
15 {
 MPI_Comm comm = xmp_get_mpi_comm(); // get the MPI communicator of p(2:3)

 int rank, size;
 MPI_Comm_rank(comm, &rank);
 MPI_Comm_size(comm, &size);
20 }

 xmp_finalize_mpi();

25 return 0;
}
```

001  
002  
003  
004  
005  
006  
007  
008  
009  
010  
011  
012  
013  
014  
015  
016  
017  
018  
019  
020  
021  
022  
023  
024  
025  
026  
027  
028  
029  
030  
031  
032  
033  
034  
035  
036  
037  
038  
039  
040  
041  
042  
043  
044  
045  
046  
047  
048  
049  
050  
051  
052  
053  
054  
055  
056  
057

## Appendix B

# Interface to Numerical Libraries

This chapter describes the XcalableMP interfaces to existing MPI parallel libraries, which is effective to achieve high productivity and performance of XcalableMP programs.

### B.1 Design of the Interface

A recommended design of the interface is as follows:

- Numerical library routines can be invoked by an XcalableMP procedure through an interface procedure (Figure B.1).

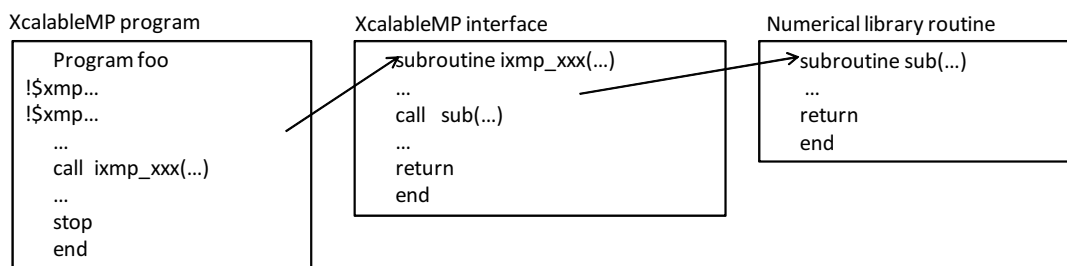

Figure B.1: Invocation of a Library Routine through an Interface Procedure

- When the numerical library routine needs information on an global array, the interface extracts it from the descriptor using some query routines provided by XcalableMP and passes it to the numerical library routine as arguments.
- The interface does not affect the behavior of numerical library routines except for restrictions concerning the XcalableMP specification.

### B.2 Extended Mapping Inquiry Functions

In this section, the extended mapping inquiry functions, which are implementation-dependent, are shown. Specifications of the functions below are from the Omni XcalableMP compiler (<http://www.xcalablemp.org/download.html>).

**B.2.1 xmp\_array\_gtol**

```

001 [F] integer function xmp_array_gtol(d, g_idx, l_idx)
002 type(xmp_desc) d
003 integer g_idx(NDIMS)
004 integer l_idx(NDIMS)
005
006 [C] void xmp_array_gtol(xmp_desc_t d, int g_idx[], int l_idx[])
007
008
009

```

**Synopsis**

The `xmp_array_gtol` function translates an index (specified by `g_idx`) of a global array (specified by `d`) into the corresponding index of its local section and sets to an array specified by `l_idx`. If the element of the specified index does not reside in the caller of the function, the resulting array is set to an unspecified value.

**Input Arguments**

- `d` is a descriptor of a global array.
- [F] `g_idx` is a rank-one integer array of the size equal to the rank of the target global array specified by `d`. `NDIMS` is the rank of the target global array.
- [C] `g_idx` is a one-dimensional integer array.

**Output Arguments**

- [F] `l_idx` is a rank-one integer array of the size equal to the rank of the target global array specified by `d`. `NDIMS` is the rank of the target global array.
- [C] `l_idx` is a one-dimensional integer array.

**B.2.2 xmp\_array\_lsize****Format**

```

037 [F] integer function xmp_array_lsize(d, dim, lsize)
038 type(xmp_desc) d
039 integer dim
040 integer lsize
041 [C] int xmp_array_lsize(xmp_desc_t d, int dim, int lsize)
042
043

```

**Synopsis**

The `xmp_array_lsize` function provides the local size of each dimension of the target global array. Note that the local size includes the size of the shadow.

**Input Arguments**

- `d` is a descriptor of a global array.
- `dim` is the target dimension of the global array.

**Output Arguments**

- `lsize` is the local size of the target dimension of the global array.

**B.2.3 xmp\_array\_laddr****Format**

```
[C] int xmp_array_laddr(xmp_desc_t d, void **laddr)
```

**Synopsis**

The `xmp_array_laddr` function provides the local address of the target global array.

**Input Arguments**

- `d` is a descriptor of a global array.

**Output Arguments**

- `laddr` is the local address of the target global array.

**B.2.4 xmp\_array\_lead\_dim****Format**

```
[F] integer function xmp_array_lead_dim(d, size)
 type(xmp_desc) d
 integer size(N)
[C] int xmp_array_lead_dim(xmp_desc_t d, int size[])
```

**Synopsis**

The `xmp_array_lead_dim` function provides the leading dimension of each local section of the target global array.

**Input Arguments**

- `d` is a descriptor of a global array.

**Output Arguments**

- `size` is a one-dimensional integer array the extent of which must be more than or equal to the rank of the target global array.

**B.3 Example**

This section shows the interface to ScaLAPACK as an example of the XscalableMP interface to numerical libraries.

ScaLAPACK is a linear algebra library for distributed-memory. Communication processes in the ScaLAPACK routines depends on BLACS (Basic Linear Algebraic Communication Subprograms). ScaLAPACK library routines invoked from XscalableMP procedures also depend on BLACS.

**Example 1** This example shows an implementation of the interface for the ScaLAPACK driver routine `pdgesv`.



```

001 XcalableMP Fortran
002 subroutine ixmp_pdgesv(n,nrhs,a,ia,ja,da,ipiv,b,ib,jb,db,ictxt,info)
003
004 use xmp_lib
005
006 integer n,nrhs,ia,ja,ib,jb,ictxt,info,desca(9),descb(9),ierr
007 double precision a,b
008 type(xmp_desc) da,db,dta,dtb
009
010 integer lbound_a1,ubound_a1,lbound_a2,ubound_a2
011 integer blocksize_a1,blocksize_a2,lead_dim_a
012 integer lbound_b1,ubound_b1,lbound_b2,ubound_b2
013 integer blocksize_b1,blocksize_b2,lead_dim_b
014
015 ierr=xmp_array_lbound(da,1,lbound_a1)
016 ierr=xmp_array_ubound(da,1,ubound_a1)
017 ierr=xmp_array_lbound(da,2,lbound_a2)
018 ierr=xmp_array_ubound(da,2,ubound_a2)
019 ierr=xmp_align_template(da,dta)
020 ierr=xmp_dist_blocksize(dta,1,blocksize_a1)
021 ierr=xmp_dist_blocksize(dta,2,blocksize_a2)
022 ierr=xmp_array_lead_dim(da,1,lead_dim_a)
023
024 ierr=xmp_array_lbound(db,1,lbound_b1)
025 ierr=xmp_array_ubound(db,1,ubound_b1)
026 ierr=xmp_array_lbound(db,2,lbound_b2)
027 ierr=xmp_array_ubound(db,2,ubound_b2)
028 ierr=xmp_align_template(db,dtb)
029 ierr=xmp_dist_blocksize(dtb,1,blocksize_b1)
030 ierr=xmp_dist_blocksize(dtb,2,blocksize_b2)
031 ierr=xmp_array_lead_dim(db,1,lead_dim_b)
032
033 desca(1)=1
034 desca(2)=ictxt
035 desca(3)=ubound_a1-lbound_a1+1
036 desca(4)=ubound_a2-lbound_a2+1
037 desca(5)=blocksize_a1
038 desca(6)=blocksize_a2
039 desca(7)=0
040 desca(8)=0
041 desca(9)=lead_dim_a
042
043 descb(1)=1
044 descb(2)=ictxt
045 descb(3)=ubound_b1-lbound_b1+1
046 descb(4)=ubound_b2-lbound_b2+1
047 descb(5)=blocksize_b1
048 descb(6)=blocksize_b2
049 descb(7)=0
050 descb(8)=0
051 descb(9)=lead_dim_b
052
053
054
055
056
057

```

|    |                                                                                    |                                        |
|----|------------------------------------------------------------------------------------|----------------------------------------|
| 50 | <pre> call pdgesv(n,nhrs,a,ia,ja,desca,ipiv,b,ib,jb,descb,info)  return end </pre> | 001<br>002<br>003<br>004<br>005<br>006 |
| 55 |                                                                                    | 007<br>008                             |

**Example 2** This example shows an XcalableMP procedure using the interface of Example 1.

|                    |                                                                                                                                                                                                                                                                                                                                                                                                                                                                                                                                                                                                                                                                                                                                                                                                                                                                                |                                                                                                                                                                                                                                                                                                                                                     |
|--------------------|--------------------------------------------------------------------------------------------------------------------------------------------------------------------------------------------------------------------------------------------------------------------------------------------------------------------------------------------------------------------------------------------------------------------------------------------------------------------------------------------------------------------------------------------------------------------------------------------------------------------------------------------------------------------------------------------------------------------------------------------------------------------------------------------------------------------------------------------------------------------------------|-----------------------------------------------------------------------------------------------------------------------------------------------------------------------------------------------------------------------------------------------------------------------------------------------------------------------------------------------------|
| XcalableMP Fortran |                                                                                                                                                                                                                                                                                                                                                                                                                                                                                                                                                                                                                                                                                                                                                                                                                                                                                |                                                                                                                                                                                                                                                                                                                                                     |
| 5                  | <pre> program xmptdgesv  use xmp_lib  double precision a(1000,1000) double precision b(1000) integer ipiv(2*1000,2) !\$xmp nodes p(2,2) !\$xmp template t(1000,1000) !\$xmp template t1(2*1000,2) !\$xmp distribute t(block,block) onto p !\$xmp distribute t1(block,block) onto p !\$xmp align a(i,j) with t(i,j) !\$xmp align ipiv(i,j) with t1(i,j) !\$xmp align b(i) with t(i,*) ... integer i,j,ictxt integer m=1000,n=1000,nprow=2,npcol=2 integer icontxt=-1,iwhat=0 integer nrhs=1,ia=1,ja=1,ib=1,jb=1,info character*1 order ... order="C" ... call blacs_get(icontxt,iwhat,ictxt) call blacs_gridinit(ictxt,order,nprow,npcol) ... !\$xmp loop (i,j) on t(i,j) do j=1,n do i=1,m a(i,j) = ... end do end do ... !\$xmp loop on t(i,*) do i=1,m b(i)= ... end do ... call ixmp_pdgesv(n,nrhs,a,ia,ja,xmp_desc_of(a),ipiv, * b,ib,jb,xmp_desc_of(b),ictxt,info) </pre> | 009<br>010<br>011<br>012<br>013<br>014<br>015<br>016<br>017<br>018<br>019<br>020<br>021<br>022<br>023<br>024<br>025<br>026<br>027<br>028<br>029<br>030<br>031<br>032<br>033<br>034<br>035<br>036<br>037<br>038<br>039<br>040<br>041<br>042<br>043<br>044<br>045<br>046<br>047<br>048<br>049<br>050<br>051<br>052<br>053<br>054<br>055<br>056<br>057 |

```
001 ...
002 call blacs_gridexit(ictxt)
003 ...
004 stop
005 end
006
```

45

```
007
008
009
010
011
012
013
014
015
016
017
018
019
020
021
022
023
024
025
026
027
028
029
030
031
032
033
034
035
036
037
038
039
040
041
042
043
044
045
046
047
048
049
050
051
052
053
054
055
056
057
```

## Appendix C

# Memory-layout Model

In this chapter, the memory-layout model of global data in the Omni XcalableMP compiler (<http://www.xcalablemp.org/download.html>) is presented for reference.

The XcalableMP specification says that a global array is distributed onto a node array according to the data-mapping directives and, as a result, a node owns a set of elements.

On each node, all and only the elements of the global array that it owns are gathered to form the local array of the same rank as the global. For each axis of the global data, all and only the indices that the node owns are packed to the axis of the local array so that sequence can be maintained, with shadow area, if any, added at the lower and/or upper bound of the axis.

Eventually the local array is stored in memory on each node according to the rule for storing arrays in the base language, that is, in row-major order in XMP/Fortran and in column-major order in XMP/C.

Note that, as a result of the model above, memory usage can be non-uniform among the nodes.

### Example

```
----- XcalableMP Fortran -----
!$xmp nodes p(4,4)
!$xmp template t(64,64)
!$xmp distribute t(block,block) onto p
5 real a(64,64)
!$xmp align a(i,j) with t(i,j)
!$xmp shadow a(1,1)
```

The array `a` is distributed by a format of `(block,block)` onto a two-dimensional node array `p` and each node owns a local array including a shadow area. Then the local array is stored in memory on each node as shown in Figure C.1.

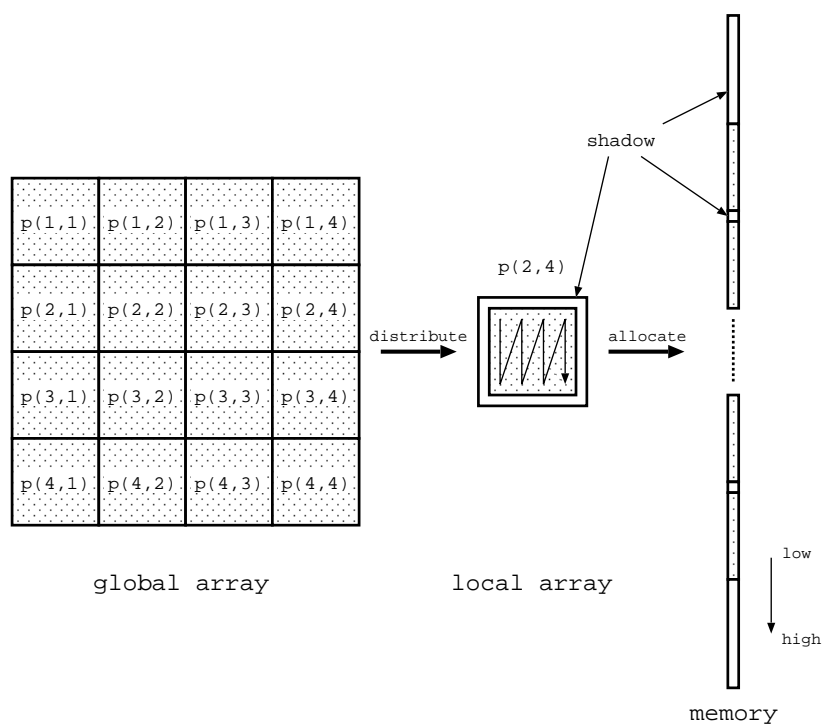

Figure C.1: Example of Memory Layout in the Omni XcalableMP compiler

001  
002  
003  
004  
005  
006  
007  
008  
009  
010  
011  
012  
013  
014  
015  
016  
017  
018  
019  
020  
021  
022  
023  
024  
025  
026  
027  
028  
029  
030  
031  
032  
033  
034  
035  
036  
037  
038  
039  
040  
041  
042  
043  
044  
045  
046  
047  
048  
049  
050  
051  
052  
053  
054  
055  
056  
057

# Appendix D

## XcalableMP I/O

### D.1 Categorization of I/O

XcalableMP has three kinds of I/O.

#### D.1.1 Local I/O

Local I/O is the way to use I/O statements and standard I/O functions in the base languages, in which I/O statements and functions are used without any directives.

I/O statements (in XcalableMP Fortran) and I/O functions (in XcalableMP C) are executed in local similar to other execution statements. It depends on the system which nodes can handle the I/O statements and functions.

Local I/O can read a file written by the base language and, vice versa.

[F] A name of a global array in the I/O list describes the entire area of the array located in each node.

An array element of a global array can be referred to as an I/O item only in the node where it is located.

[F] Any array section of a global array cannot be referred to as an I/O item.

#### D.1.2 Master I/O[F]

Master I/O is input and output for the file that corresponds to an executing node set. Master I/O is collective execution.

In master I/O, a global data is input and output as if it was executed only by a master node, which represents the executing node set, through its local copy of the data.

The master node is chosen among the executing node set arbitrarily by the system, and is unique to the executing node set during execution of the program.

Master I/O is provided in the form of directives of XcalableMP Fortran.

A global array as an I/O item is accessed in the sequential order of array elements. When a local variable is read from a file, the value is copied to all nodes of the executing node set. When a local variable or an expression is written to a file, only the value of the data on the master node is written.

Master I/O can read a file written by the base language, and vice versa.

#### D.1.3 Global I/O

Global I/O is input and output for the file that corresponds to an executing node set. Some executions of global I/O are collective and the others are independent. In a large system with

Table D.1: Global I/O

|                | independent/collective | access method     |
|----------------|------------------------|-------------------|
| Collective I/O | collective             | sequential access |
| Atomic I/O     | independent            | sequential access |
| Direct I/O     | independent            | direct access     |

many nodes, global I/O can be expected higher speed and less memory consumption execution than master I/O.

[F] It is provided in the form of directives for a part of I/O statements, such as OPEN, CLOSE, READ and WRITE statements.

[C] It is provided in the form of service functions and the include file.

Global I/O can handle only unformatted (binary) files. In XcalableMP Fortran, implied DO loops and some specifiers cannot be used. In XcalableMP C, formatted I/O libraries, including `fprintf()` and `fscanf()`, are not provided.

Global I/O can read a file written in MPI-IO, and vice versa.

[F] File formats are not compatible between XcalableMP Fortran and the base language because global I/O does not generate or access the file header and footer particular to the base language.

There are three kinds of global I/O, as shown in Table D.1. **Collective** global I/O is collective execution and sequential file access. It handles global data in the sequential order, similar to master I/O. **Atomic** global I/O is independent execution and sequential file access. Executing nodes share file positioning of the global I/O file and execute each I/O statement and library call mutually. **Direct** global I/O is independent execution and direct file access. Each executing node has its own file positioning and accesses a shared file independently.

### Restriction

- The name of a global array may not be declared in a namelist group. That is, NAMELIST I/O is not allowed for global arrays.

### Advice to programmers

Local I/O is useful for debugging focusing on a node since local I/O is executed on each node individually.

Master I/O is a directive extension, in which the execution result matches the one of the base language ignoring directive lines.

Global I/O aims for highly-parallel I/O using thousands of nodes. It is limited to binary files. It avoids extreme concentration of computational load and memory consumption to specific nodes using MPI-IO or other parallel I/O techniques.

## D.2 File Connection

A file is connected to a unit in XcalableMP Fortran and to a file handler in XcalableMP C. This operation is called **file connection**. Local I/O connects a file to each node independently. Master I/O and global I/O connect a file to an executing node set collectively.

There are two ways of file connections, dynamic connection and preconnection. Dynamic connection connects a file during execution of the program. Preconnection connects a file at the

beginning of execution of the program and therefore it can execute I/O statements and functions without the prior execution of an OPEN statement or a function call to open the file.

### D.2.1 File Connection in Local I/O

The language processor of the base language connects the file to each node. It is implementation dependent which nodes can access the standard input, output and error files. It is also implementation dependent how the accesses to the files with the same name by multiple nodes behaves. The only primary node can access the standard input, output and error files.

### D.2.2 [F] File Connection in Master I/O

An OPEN statement specified with a master I/O directive connects a file to the executing node set. When a master I/O file is connected by a READ statement or a WRITE statement without encountering any OPEN statement, the name and attributes of the file depend on the language system of the base language. Disconnection from a master I/O file is executed by a CLOSE statement or termination of the program.

Dynamic connection must be executed collectively by all nodes sharing the file with the same unit number. Two executing node sets may employ the same unit number only if they have no common node.

The standard input, output and error files are preconnected to the entire node set. Therefore, master I/O executed on the entire node set is always allowed without OPEN and CLOSE statements.

### D.2.3 File Connection in Global I/O

Dynamic connection of global I/O is collective execution and is valid for the executing node set. Global I/O files cannot be preconnected.

[F]

An OPEN statement specified with a global I/O directive connects a file to the executing node set. Disconnection from a global I/O file is executed by a CLOSE statement or termination of the program.

Dynamic connection must be executed collectively by all nodes sharing the file with the same unit number. Two executing node sets may employ the same unit number only if they have no common node.

[C]

A library function to open a global I/O file connects the file to the executing node set. Disconnection from a global I/O file is executed by a library function to close the file or termination of the program.

## D.3 Master I/O

A master I/O construct executes data transfer between a file and an executing node set via a master node of the executing node set. For a global array, the virtual sequential order of the array elements is visible.



### D.3.1 master\_io Construct

#### Syntax

```
[F] !$xmp master_io
 io-statement
[F] !$xmp master_io begin
 io-statement
 ...
 !$xmp master_io end
where io-statement is one of:
```

- OPEN statement
- CLOSE statement
- READ statement
- WRITE statement
- PRINT statement
- BACKSPACE statement
- ENDFILE statement
- REWIND statement
- INQUIRE statement

#### Restriction

- The following items including a global array or a subobject of a global array must not appear in an input item or output item.
  - A substring-range
  - A section-subscript
  - An expression including operators
  - An *io-implied-do-control*
- An I/O statement specified with a master I/O directive must be executed collectively on the node set that is connected to the file.
- Internal file I/O is not allowed as master I/O.

#### Description

An I/O statement specified with master I/O directive accesses a file whose format is the same as the one of the base language. The access, including connection, disconnection, input and output, file positioning, and inquiry, is collective and must be executed on the same node set as the one where the file was connected.

A master node, a unique node to an executing node set, is chosen by the language system. Master I/O works as if all file accesses were executed only on the master node.

The operations for I/O items are summarized in Table D.2.

Table D.2: Operations for I/O

|             | <b>I/O item</b>               | <b>operation</b>                                                                                                                                                                                   |
|-------------|-------------------------------|----------------------------------------------------------------------------------------------------------------------------------------------------------------------------------------------------|
| input item  | name of global array          | The data elements that are read from the file in the sequential order of array elements are distributed onto the global array on the node set. The file positioning increases by the size of data. |
|             | array element of global array | The data element that is read from the file is copied to the element of the global array on the node to which it is mapped. The file positioning increases by the size of data.                    |
|             | local variable                | The data element that is read from the file is replicated to the local variables on all nodes of the executing node set. The file positioning increases by the size of data.                       |
|             | implied DO loop               | For each input item, repeat the above operation.                                                                                                                                                   |
| output item | name of global array          | The data elements of the global array are collected and are written to the file in the sequential order of array elements. The file positioning increases by the size of data.                     |
|             | array element of global array | The element of the global array is written to the file. A file position increases by the size of data.                                                                                             |
|             | local variable and expression | The value evaluated on the master node is written to the file. The file positioning increases by the size of data.                                                                                 |
|             | implied DO loop               | For each output item, repeat the above operation.                                                                                                                                                  |

Namelist input and output statements cannot treat global arrays. A namelist output statement writes the values on the master node to the file. In the namelist input, each item of the namelist is read from the file to the master node if it is recorded in the file. And then all items of the namelist are replicated onto all nodes of the executing node set from the master node even if some items are not read from the file.

IOSTAT and SIZE specifiers and specifiers of the INQUIRE statement that can return values always return the same value among the executing node set.

When a condition specified with ERR, END or EOR specifier is satisfied, all nodes of executing node set are branched together to the same statement.

### Advice to implementers

It is recommended to provide such a compiler option that local I/O statements (specified without directives) are regarded as master I/O statements (specified with `master_io` directives).

## D.4 [F] Global I/O

Global I/O performs unformatted data transfer and can be expected to be higher performance and lower memory consumption than master I/O. The file format is compatible with the one in MPI-IO.

Global I/O consists of three kinds, collective I/O, atomic I/O, and direct I/O.

### D.4.1 Global I/O File Operation

`global_io` construct is defined as follows.

#### Syntax

```
[F] !$xmp global_io [atomic / direct]
 io-statement

[F] !$xmp global_io [atomic / direct] begin
 io-statement
 ...
 !$xmp end global_io
```

The first syntax is just a shorthand of the second syntax.

#### Restriction

I/O statements and specifiers available for an *io-statement* are shown in the following table. Definition of each specifier is described in the specification of the base language.

Case of `global_io` construct without a direct clause:

| I/O statement | available specifiers                                       |
|---------------|------------------------------------------------------------|
| OPEN          | UNIT, IOSTAT, FILE, STATUS, POSITION, ACTION, ACCESS, FORM |
| CLOSE         | UNIT, IOSTAT, STATUS                                       |
| READ          | UNIT, IOSTAT                                               |
| WRITE         | UNIT, IOSTAT                                               |

Case of `global_io` construct with a direct clause:

| I/O statement | available specifiers                                   |
|---------------|--------------------------------------------------------|
| OPEN          | UNIT, IOSTAT, FILE, STATUS, RECL, ACTION, ACCESS, FORM |
| CLOSE         | UNIT, IOSTAT, STATUS                                   |
| READ          | UNIT, REC, IOSTAT                                      |
| WRITE         | UNIT, REC, IOSTAT                                      |

An input item and an output item of a data transfer statement with a `global_io` directive must be the name of a variable.

#### Description

Global I/O construct connects, disconnects, inputs and outputs the global I/O file, which is compatible with MPI-IO.

The standard input, output and error files cannot be a Global I/O file. A Global I/O file cannot preconnect to any unit or any file handler, and must explicitly be connected by the OPEN statement specified with a `global_io` directive.

The OPEN statement specified with a `global_io` directive is collective execution, and the file is shared among the executing node set. A file that has already been opened by another OPEN statement with a `global_io` directive cannot be reopened by an OPEN statement with or without a `global_io` directive before closing it.

A global I/O file must be disconnected explicitly by a CLOSE statement specified with a `global_io` directive, otherwise the result of I/O is not guaranteed. The CLOSE statement specified with a `global_io` directive is a collective execution and must be executed by the same executing node set as the one where the OPEN statement is executed.

Utilizable values of the specifiers in I/O statements are shown in the following table. Definitions of the specifiers are described in the specification of the base language.

- OPEN statement

| specifiers | value                                                       | default                                                                                     |
|------------|-------------------------------------------------------------|---------------------------------------------------------------------------------------------|
| UNIT       | external file unit (scalar constant expression)             | not omissible                                                                               |
| FILE       | file name (scalar CHARACTER expression)                     | not omissible                                                                               |
| STATUS     | 'OLD', 'NEW', 'REPLACE' or 'UNKNOWN'                        | 'UNKNOWN'                                                                                   |
| POSITION   | 'ASIS', 'REWIND' or 'APPEND'                                | 'ASIS'                                                                                      |
| ACTION     | 'READ', 'WRITE' or 'READWRITE'                              | processor dependent                                                                         |
| RECL       | the value of the record length (scalar constant expression) | not omissible                                                                               |
| ACCESS     | 'SEQUENTIAL' or 'DIRECT'                                    | 'SEQUENTIAL'                                                                                |
| FORM       | 'FORMATTED' or 'UNFORMATTED'                                | For direct access, UNFORMATTED. For sequential access, this specifier shall not be omitted. |

POSITION is available only if the directive has no direct clause. RECL is available only if the directive has a direct clause. For direct I/O, the ACCESS specifier shall appear and the value shall be evaluated to DIRECT. For collective I/O and atomic I/O, the value of the ACCESS specifier shall be evaluated to SEQUENTIAL if this specifier appears. For collective I/O and atomic I/O, the FORM specifier shall appear and the value shall be evaluated to UNFORMATTED. For direct I/O, the value of the FORM specifier shall be evaluated to UNFORMATTED if this specifier appears.

- CLOSE statement

| specifiers | value                                           | default        |
|------------|-------------------------------------------------|----------------|
| UNIT       | external file unit (scalar constant expression) | not omissible. |
| STATUS     | 'KEEP' or 'DELETE'                              | 'KEEP'         |

- READ/WRITE statement

| specifiers | value                                                          | default       |
|------------|----------------------------------------------------------------|---------------|
| UNIT       | external file unit (scalar constant expression)                | not omissible |
| REC        | the value of the number of record (scalar constant expression) | not omissible |

REC is available only if the directive has a direct clause.

- When a scalar variable of default INTEGER is specified to IOSTAT, an error code is set to the specifiers.

OPEN, CLOSE, READ and WRITE statements specified with `global_io` directives without atomic and direct clauses are called collective OPEN, collective CLOSE, collective READ, and collective WRITE statements respectively. These all statements are called collective I/O statements.

OPEN, CLOSE, READ and WRITE statements specified with `global_io` directives with atomic clauses are called atomic OPEN, atomic CLOSE, atomic READ, and atomic WRITE statements respectively. These all statements are called atomic I/O statements.

OPEN, CLOSE, READ and WRITE statements specified with `global_io` directives with direct clauses are called direct OPEN, direct CLOSE, direct READ, and direct WRITE statements respectively. These all statements are called direct I/O statements.

The file connected by a collective, atomic or direct OPEN statement can be read/be written only by the same type of READ/WRITE statements. The file can be disconnected by the same type of a CLOSE statement. Different types of global I/O cannot be executed together for the same file or the same unit. For example, atomic I/O statements cannot be executed for the unit connected by a collective OPEN statement.

#### D.4.1.1 `file_sync_all` Directive

Two data accesses conflict if they access the same absolute byte displacements of the same file and at least one is a write access. When two accesses to the same file conflict in direct or collective I/O, the following `file_sync_all` directive to the file must be executed.

#### Syntax

```
!$xmp file_sync_all([UNIT=]file-unit-number)
```

The `file_sync_all` directive is an execution directive and collective to the nodes connected to the specified file-unit-number. The execution of a `file_sync_all` directive first synchronizes all the nodes connected to the specified file-unit-number, and then causes all previous writes to the file by the nodes to be transferred to the storage device. If some nodes have made updates to the file, then all such updates become visible to subsequent reads of the file by the nodes.

#### D.4.2 Collective Global I/O Statement

Collective I/O statements read/write shared files and can handle global arrays.

All collective I/O statements execute collectively. In collective I/O, all accesses to a file, such as connection, disconnection, input and output, must be executed on the same executing node set.

The operations for I/O items are summarized in the following table.

#### D.4.3 Atomic Global I/O Statement

Atomic I/O statements read/write shared files exclusively among executing nodes in arbitrary order. Because it is a nondeterministic parallel execution, the results can differ every execution time even for the same program.

Atomic OPEN and CLOSE statements are executed collectively, while atomic READ and WRITE statements are executed independently. A file connected by an atomic OPEN statement

| I/O item    |                            | operation                                                                                                                                                      |
|-------------|----------------------------|----------------------------------------------------------------------------------------------------------------------------------------------------------------|
| input item  | name of global array       | The values read from a file are assigned to the elements of the global array. The file positioning seeks by the size of the data.                              |
|             | local variable             | The values read from the file are replicated into the local array on all executing nodes. The file positioning seeks by the length of the data.                |
| output item | name of global array       | The values of a global array are written to the file in the sequential order of the array elements. The file positioning seeks by the size of the data.        |
|             | local variable, expression | The values evaluated on a node arbitrarily selected by the language processor from the executing node set. The file positioning seeks by the size of the data. |

can be disconnected only by an atomic CLOSE statement executed on the same executing node set. Atomic READ and WRITE statements can be executed on any single node of the same executing node set.

Atomic READ and WRITE statements are exclusively executed. The unit of exclusive operation is a single READ statement or a single WRITE statement.

The initial file positioning is determined by the POSITION specifier of the atomic OPEN statement. And then, the file positioning seeks in every READ and WRITE statement by the length of the input/output data.

#### D.4.4 Direct Global I/O Statement

Direct I/O statements read/write shared files with specification of the file positioning for each node.

Direct OPEN and CLOSE statements are executed collectively, while direct READ and WRITE statements are executed independently. A file connected by a direct OPEN statement can be disconnected only by a direct CLOSE statement executed on the same executing node set. Direct READ and WRITE statements can be executed on any single node of the same executing node set.

Direct READ and WRITE statements read/write local data at the file positioning specified by the REC specifier independently. The file positioning is shifted from the top of the file by the product of the specifiers RECL (of OPEN statement) and REC (of READ and WRITE statement).

In order to guarantee the order of direct I/O statements to the same file position, the file should be closed or the file\_sync\_all directive should be executed between these statements. Otherwise, the outcome of multiple accesses to the same file position, in which at least one is a write access, is implementation dependent.

## D.5 [C] Global I/O Library

XcalableMP C provides some data types defined in the include file “xmp.h”, a set of library functions with arguments of the data types, and built-in operators to get values of the data types from names of a variable, a template, etc..

The following types are provided.

- xmp\_file\_t : file handle

001  
002  
003  
004  
005  
006  
007  
008  
009  
010  
011  
012  
013  
014  
015  
016  
017  
018  
019  
020  
021  
022  
023  
024  
025  
026  
027  
028  
029  
030  
031  
032  
033  
034  
035  
036  
037  
038  
039  
040  
041  
042  
043  
044  
045  
046  
047  
048  
049  
050  
051  
052  
053  
054  
055  
056  
057

- `xmp_rang_t` : descriptor of array section

The following library functions are provided. Collective function names end with `_all`.

- global I/O file operation
  - `xmp_fopen_all` : file open
  - `xmp_fclose_all` : file close
  - `xmp_fseek` : setting (individual) file pointer
  - `xmp_fseek_shared_all` : setting shared file pointer
  - `xmp_ftell` : displacement of (individual) file pointer
  - `xmp_ftell_shared` : displacement of shared file pointer
  - `xmp_file_sync_all` : file synchronization
- collective I/O
  - `xmp_file_set_view_all` : setting file view
  - `xmp_file_clear_view_all` : initializing file view
  - `xmp_fread_all` : collective read of local data
  - `xmp_fwrite_all` : collective write of local data
  - `xmp_fread_darray_all` : collective read of global data
  - `xmp_fwrite_darray_all` : collective write of global data
- atomic I/O
  - `xmp_fread_shared` : atomic read
  - `xmp_fwrite_shared` : atomic write
- direct I/O
  - `xmp_fread` : direct read
  - `xmp_fwrite` : direct write

## Data type

The following data types are defined in include file `xmp_io.h`.

**`xmp_file_t`** A file handler. It is connected to a file when the file is opened. It has a shared file pointer and an individual file pointer to point where to read/write data in the file.

A shared file pointer is a shared resource among all nodes of the node set that has opened the file. Atomic I/O uses a shared file pointer. An (individual) file pointer is an individual resource on each node. Collective I/O and direct I/O use individual file pointers.

These two file pointers are managed in the structure `xmp_file_t`, . and can be controlled and referenced only through the provided library functions.

**`xmp_range_t`** Descriptor of array section, including lower bound, upper bound and stride for each dimension. Functions for operating the descriptor are shown in following table. The `xmp_allocate_range()` function is used to allocate memory. The `xmp_set_range()` function is used to set ranges of a array section. The `xmp_free_range()` function releases the memory for the descriptor.

|                      |                                               |                                                                     |
|----------------------|-----------------------------------------------|---------------------------------------------------------------------|
| <b>function name</b> | <b>xmp_range_t *xmp_allocate_range(n_dim)</b> |                                                                     |
| argument             | int n_dim                                     | the number of dimensions                                            |
| return value         | xmp_range_t*                                  | descriptor of array section. NULL is returned when a program abend. |

|                      |                                                        |                                                     |
|----------------------|--------------------------------------------------------|-----------------------------------------------------|
| <b>function name</b> | <b>void xmp_set_range(rp, i_dim, lb, length, step)</b> |                                                     |
| argument             | xmp_range_t *rp                                        | descriptor                                          |
|                      | int i_dim                                              | target dimension                                    |
|                      | int lb                                                 | lower bound of array section in the dimension i_dim |
|                      | int length                                             | length of array section in the dimension i_dim      |
|                      | int step                                               | stride of array section in the dimension i_dim      |

001  
002  
003  
004  
005  
006  
007  
008  
009  
010  
011  
012  
013  
014  
015  
016  
017  
018  
019  
020  
021  
022  
023  
024  
025  
026  
027  
028  
029  
030  
031  
032  
033  
034  
035  
036  
037  
038  
039  
040  
041  
042  
043  
044  
045  
046  
047  
048  
049  
050  
051  
052  
053  
054  
055  
056  
057



|                      |                                |                              |
|----------------------|--------------------------------|------------------------------|
| <b>function name</b> | <b>void xmp_free_range(rp)</b> |                              |
| argument             | xmp_range_t *rp                | descriptor of array section. |

## D.5.1 Global I/O File Operation

### D.5.1.1 xmp\_fopen\_all

xmp\_fopen\_all opens a global I/O file. Collective execution.

|                      |                                                |                                                        |
|----------------------|------------------------------------------------|--------------------------------------------------------|
| <b>function name</b> | <b>xmp_file_t *xmp_fopen_all(fname, amode)</b> |                                                        |
| argument             | const char *fname                              | file name                                              |
|                      | const char *amode                              | equivalent to fopen of POSIX. combination of “rwa+”    |
| return value         | xmp_file_t*                                    | file structure. NULL is returned when a program abend. |

File view is initialized, where file view is based on the MPI-IO vile view mechanism. The value of shared and individual file pointers depend on the value of amode.

| amode | intended purpose                                                                                                                                                  |
|-------|-------------------------------------------------------------------------------------------------------------------------------------------------------------------|
| r     | Open for reading only. File pointer points the beginning of the file.                                                                                             |
| r+    | Open an existing file for update (reading and writing). File pointer points the beginning of the file.                                                            |
| w     | Create for writing. If a file by that name already exists, it will be overwritten. File pointer points the beginning of the file.                                 |
| w+    | Create a new file for update (reading and writing). If a file by that name already exists, it will be overwritten. File pointer points the beginning of the file. |
| a     | Append; open for writing at end-of-file or create for writing if the file does not exist. File pointer points the end of the file.                                |
| a+    | Open for append; open (or create if the file does not exist) for update at the end of the file. File pointer points the beginning of the file.                    |

### D.5.1.2 xmp\_fclose\_all

xmp\_fclose\_all closes a global I/O file. Collective execution.

|                      |                                |                                                                                                                    |
|----------------------|--------------------------------|--------------------------------------------------------------------------------------------------------------------|
| <b>function name</b> | <b>int *xmp_fclose_all(fh)</b> |                                                                                                                    |
| argument             | xmp_file_t *fh                 | file structure                                                                                                     |
| return value         | int                            | 0: normal termination<br>1: abnormal termination. fh is NULL.<br>2: abnormal termination. error in MPI_File_close. |

### D.5.1.3 xmp\_fseek

xmp\_fseek sets the individual file pointer in the file structure. Independent execution.

| function name | <b>int xmp_fseek(fh, offset, whence)</b> |                                                                                                                            |
|---------------|------------------------------------------|----------------------------------------------------------------------------------------------------------------------------|
| argument      | xmp_file_t *fh                           | file structure                                                                                                             |
|               | long long offset                         | displacement of current file view from position of whence                                                                  |
|               | int whence                               | choose file position<br>SEEK_SET: the beginning of the file<br>SEEK_CUR: current position<br>SEEK_END: the end of the file |
| return value  | int                                      | 0: normal termination<br>an integer other than 0: abnormal termination                                                     |

#### D.5.1.4 xmp\_fseek\_shared

xmp\_fseek\_shared sets the shared file pointer in the file structure. Independent execution.

| function name | <b>int xmp_fseek_shared(fh, offset, whence)</b> |                                                                                                                            |
|---------------|-------------------------------------------------|----------------------------------------------------------------------------------------------------------------------------|
| argument      | xmp_file_t *fh                                  | file structure                                                                                                             |
|               | long long offset                                | displacement of current file view from position of whence                                                                  |
|               | int whence                                      | choose file position<br>SEEK_SET: the beginning of the file<br>SEEK_CUR: current position<br>SEEK_END: the end of the file |
| return value  | int                                             | 0: normal termination<br>an integer other than 0: abnormal termination                                                     |

#### D.5.1.5 xmp\_ftell

xmp\_ftell inquires the position of the individual file pointer in the file structure. Independent execution.

| function name | <b>long long xmp_ftell(fh)</b> |                                                                                                                                                                                                       |
|---------------|--------------------------------|-------------------------------------------------------------------------------------------------------------------------------------------------------------------------------------------------------|
| argument      | xmp_file_t *fh                 | file structure                                                                                                                                                                                        |
| return value  | long long                      | Upon successful completion, the function shall open the file and return a non-negative integer representing the lowest numbered unused file descriptor. Otherwise, negative number shall be returned. |

#### D.5.1.6 xmp\_ftell\_shared

xmp\_ftell\_shared inquires the position of shared file pointer in the file structure. Independent execution.

001  
002  
003  
004  
005  
006  
007  
008  
009  
010  
011  
012  
013  
014  
015  
016  
017  
018  
019  
020  
021  
022  
023  
024  
025  
026  
027  
028  
029  
030  
031  
032  
033  
034  
035  
036  
037  
038  
039  
040  
041  
042  
043  
044  
045  
046  
047  
048  
049  
050  
051  
052  
053  
054  
055  
056  
057

| function name | long long xmp_ftell_shared(fh) |                                                                                                                                                                                                       |
|---------------|--------------------------------|-------------------------------------------------------------------------------------------------------------------------------------------------------------------------------------------------------|
| argument      | xmp_file_t *fh                 | file structure                                                                                                                                                                                        |
| return value  | long long                      | Upon successful completion, the function shall open the file and return a non-negative integer representing the lowest numbered unused file descriptor. Otherwise, negative number shall be returned. |

### D.5.1.7 xmp\_file\_sync\_all

xmp\_file\_sync\_all guarantees completion of access to the file from nodes sharing the file. Two data accesses conflict if they access the same absolute byte displacements of the same file and at least one is a write access. When two accesses A1 and A2 to the same file conflict in direct or collective I/O, an xmp\_file\_sync\_all to the file must be invoked between A1 and A2, otherwise the outcome of the accesses is undefined. Collective execution.

| function name | int xmp_file_sync_all(fh) |                                                                        |
|---------------|---------------------------|------------------------------------------------------------------------|
| argument      | xmp_file_t *fh            | file structure                                                         |
| return value  | int                       | 0: normal termination<br>an integer other than 0: abnormal termination |

## D.5.2 Collective Global I/O Functions

Collective I/O is executed collectively but using the individual pointer. It reads/writes data from the position of the individual file pointer and moves the position by the length of the data.

Before the file access, a file view is often specified. A file view, like a window to the file, spans the positions corresponding to the array elements that each node owns. For more details of file view, refer to the MPI 2.0 specification.

### D.5.2.1 xmp\_file\_set\_view\_all

xmp\_file\_set\_view\_all sets a file view to the file. Collective execution.

| function name | int xmp_file_set_view_all(fh, disp, desc, rp) |                                                                        |
|---------------|-----------------------------------------------|------------------------------------------------------------------------|
| argument      | xmp_file_t *fh                                | file structure                                                         |
|               | long long disp                                | displacement from the beginning of the file.                           |
|               | xmp_desc_t desc                               | descriptor                                                             |
|               | xmp_range_t *rp                               | range descriptor                                                       |
| return value  | int                                           | 0: normal termination<br>an integer other than 0: abnormal termination |

The file view of distributed *desc* limited to range *rp* is set into file structure *fh*.

**D.5.2.2 xmp\_file\_clear\_view\_all**

xmp\_file\_clear\_view\_all clears the file view. Collective execution.

The positions of the shared and individual file pointers are set to disp and the elemental data type and the file type are set to MPI.BYTE.

| function name | int xmp_file_clear_view_all(fh, disp) |                                                                        |
|---------------|---------------------------------------|------------------------------------------------------------------------|
| argument      | xmp_file_t *fh                        | file structure                                                         |
|               | long long disp                        | displacement from the beginning of the file.                           |
| return value  | int                                   | 0: normal termination<br>an integer other than 0: abnormal termination |

**D.5.2.3 xmp\_fread\_all**

xmp\_fread\_all reads the same data from the position of the shared file pointer onto the all executing nodes. Collective execution.

| function name | size_t xmp_fread_all(fh, buffer, size, count) |                                                                                                         |
|---------------|-----------------------------------------------|---------------------------------------------------------------------------------------------------------|
| argument      | xmp_file_t *fh                                | file structure                                                                                          |
|               | void *buffer                                  | beginning address of read variables                                                                     |
|               | size_t size                                   | the size of a read data element                                                                         |
|               | size_t count                                  | the number of read data elements                                                                        |
| return value  | size_t                                        | Upon successful completion, return the size of read data. Otherwise, negative number shall be returned. |

**D.5.2.4 xmp\_fwrite\_all**

xmp\_fwrite\_all writes individual data on the all executing nodes to the position of the shared file pointer. Collective execution.

It is assumed that the file view is set previously. Each node writes its data into its own file view.

| function name | size_t xmp_fwrite_all(fh, buffer, size, count) |                                                                                                            |
|---------------|------------------------------------------------|------------------------------------------------------------------------------------------------------------|
| argument      | xmp_file_t *fh                                 | file structure                                                                                             |
|               | void *buffer                                   | beginning address of written variables                                                                     |
|               | size_t size                                    | the size of a written data element                                                                         |
|               | size_t count                                   | the number of written data elements                                                                        |
| return value  | size_t                                         | Upon successful completion, return the size of written data. Otherwise, negative number shall be returned. |

**D.5.2.5 xmp\_fread\_darray\_all**

xmp\_fread\_darray\_all reads data cooperatively to the global array from the position of the shared file pointer.

Data is read from the file to distributed *desc* limited to range *rp*.

| function name | size_t xmp_fread_darray_all(fh, desc, rp) |                                                                                                         |
|---------------|-------------------------------------------|---------------------------------------------------------------------------------------------------------|
| argument      | xmp_file.t *fh                            | file structure                                                                                          |
|               | xmp_desc.t desc                           | descriptor                                                                                              |
|               | xmp_range.t *rp                           | range descriptor                                                                                        |
| return value  | size_t                                    | Upon successful completion, return the size of read data. Otherwise, negative number shall be returned. |

#### D.5.2.6 xmp\_fwrite\_darray\_all

xmp\_fwrite\_darray\_all writes data cooperatively from the global array to the position of the shared file pointer.

| function name | size_t xmp_fwrite_darray_all(fh, desc, rp) |                                                                                                         |
|---------------|--------------------------------------------|---------------------------------------------------------------------------------------------------------|
| argument      | xmp_file.t *fh                             | file structure                                                                                          |
|               | xmp_desc.t desc                            | descriptor                                                                                              |
|               | xmp_range.t *rp                            | range descriptor                                                                                        |
| return value  | size_t                                     | Upon successful completion, return the size of read data. Otherwise, negative number shall be returned. |

Data is written from distributed *desc* limited to range *rp* to the file.

### D.5.3 Atomic Global I/O Functions

Atomic I/O is executed independently but using the shared pointer. It exclusively reads/writes local data from the position of the shared file pointer and moves the position by the length of the data.

Before atomic I/O is executed, the file view must be cleared.

[Rationale]

Though the file views must be the same on all processes in order to use the shared file pointer, xmp\_file\_set\_view\_all function may set different file views for all nodes. Thus, before atomic I/O is used, the file view must be cleared.

#### D.5.3.1 xmp\_fread\_shared

xmp\_fread\_shared exclusively reads local data form the position of the shared file pointer and moves the position by the length of the data. Independently execution.

| function name | size_t xmp_fread_shared(fh, buffer, size, count) |                                                                                                         |
|---------------|--------------------------------------------------|---------------------------------------------------------------------------------------------------------|
| argument      | xmp_file.t *fh                                   | file structure                                                                                          |
|               | void *buffer                                     | beginning address of read variables                                                                     |
|               | size_t size                                      | the size of a read data element                                                                         |
|               | size_t count                                     | the number of read data elements                                                                        |
| return value  | size_t                                           | Upon successful completion, return the size of read data. Otherwise, negative number shall be returned. |

### D.5.3.2 xmp\_fwrite\_shared

xmp\_fwrite\_shared exclusively writes local data to the position of the shared file pointer and moves the position by the length of the data. Independent execution.

| function name | size_t xmp_fwrite_shared(fh, buffer, size, count) |                                                                                                            |
|---------------|---------------------------------------------------|------------------------------------------------------------------------------------------------------------|
| argument      | xmp_file_t *fh                                    | file structure                                                                                             |
|               | void *buffer                                      | beginning address of written variables                                                                     |
|               | size_t size                                       | the size of a written data element                                                                         |
|               | size_t count                                      | the number of written data elements                                                                        |
| return value  | size_t                                            | Upon successful completion, return the size of written data. Otherwise, negative number shall be returned. |

## D.5.4 Direct Global I/O Functions

Direct I/O is executed independently and using the individual pointer. It individually reads/writes local data from the position of the individual file pointer and moves the position by the length of the data taking account of the file view.

In order to guarantee the order by xmp\_fread and xmp\_fwrite functions to the same file position, the file should be closed or the xmp\_file\_sync\_all function should be executed between these functions. Otherwise, the outcome of multiple accesses to the same file position, in which at least one is the xmp\_fwrite function, is implementation dependent.

### Advice to programmers

Function xmp\_fseek is useful to set the individual file pointer. It is not recommended using the file view together because of complexity.

#### D.5.4.1 xmp\_fread

xmp\_fread reads data from the position of the individual file pointer and moves the position by the length of the data. Independent execution.

| function name | size_t xmp_fread(fh, buffer, size, count) |                                                                                                         |
|---------------|-------------------------------------------|---------------------------------------------------------------------------------------------------------|
| argument      | xmp_file_t *fh                            | file structure                                                                                          |
|               | void *buffer                              | beginning address of read variables                                                                     |
|               | size_t size                               | the size of a read data element                                                                         |
|               | size_t count                              | the number of read data elements                                                                        |
| return value  | size_t                                    | Upon successful completion, return the size of read data. Otherwise, negative number shall be returned. |

#### D.5.4.2 xmp\_fwrite

xmp\_fwrite writes data to the position of the individual file pointer and moves the position by the length of the data. Independent execution.

001  
002  
003  
004  
005  
006  
007  
008  
009  
010  
011  
012  
013  
014  
015  
016  
017  
018  
019  
020  
021  
022  
023  
024  
025  
026  
027  
028  
029  
030  
031  
032  
033  
034  
035  
036  
037  
038  
039  
040  
041  
042  
043  
044  
045  
046  
047  
048  
049  
050  
051  
052  
053  
054  
055  
056  
057

| function name | <b>size_t xmp_fwrite(fh, buffer, size, count)</b> |                                                                                                            |
|---------------|---------------------------------------------------|------------------------------------------------------------------------------------------------------------|
| argument      | xmp_file_t *fh                                    | file structure                                                                                             |
|               | void *buffer                                      | beginning address of written variables                                                                     |
|               | size_t size                                       | the size of a written data element                                                                         |
|               | size_t count                                      | the number of written data elements                                                                        |
| return value  | size_t                                            | Upon successful completion, return the size of written data. Otherwise, negative number shall be returned. |

# Appendix E

## Sample Programs

### Example 1

```

XcalableMP C
/*
 * A parallel explicit solver of Laplace equation in \XMP
 */
#pragma xmp nodes p(NPROCS)
5 #pragma xmp template t(1:N)
#pragma xmp distribute t(block) onto p

double u[XSIZE+2][YSIZE+2],
 uu[XSIZE+2][YSIZE+2];
10 #pragma xmp align u[i][*] to t(i)
#pragma xmp align uu[i][*] to t(i)
#pragma xmp shadow uu[1:1][0:0]

lap_main()
15 {
 int x,y,k;
 double sum;
 for(k = 0; k < NITER; k++){
 /* old <- new */
20 #pragma xmp loop on t(x)
 for(x = 1; x <= XSIZE; x++)
 for(y = 1; y <= YSIZE; y++)
 uu[x][y] = u[x][y];
 #pragma xmp reflect (uu)
25 #pragma xmp loop on t(x)
 for(x = 1; x <= XSIZE; x++)
 for(y = 1; y <= YSIZE; y++)
 u[x][y] = (uu[x-1][y] + uu[x+1][y] +
30 uu[x][y-1] + uu[x][y+1])/4.0;
 }

 sum = 0.0;
 #pragma xmp loop on t[x] reduction(+:sum)
 for(x = 1; x <= XSIZE; x++)
35 for(y = 1; y <= YSIZE; y++)
```

001  
002  
003  
004  
005  
006  
007  
008  
009  
010  
011  
012  
013  
014  
015  
016  
017  
018  
019  
020  
021  
022  
023  
024  
025  
026  
027  
028  
029  
030  
031  
032  
033  
034  
035  
036  
037  
038  
039  
040  
041  
042  
043  
044  
045  
046  
047  
048  
049  
050  
051  
052  
053  
054  
055  
056  
057



```

001 sum += (uu[x][y]-u[x][y]);
002 #pragma xmp task on p(1)
003 printf("sum = %g\n",sum);
004 }
005
006

```

**Example 2**

```

007
008 XcalableMP C
009
010 /*
011 * Linpack in XcalableMP (Gaussian elimination with partial pivoting)
012 * 1D distribution version
013 */
014 5 #pragma xmp nodes p(*)
015 #pragma xmp template t(0:LDA-1)
016 #pragma xmp distribute t(cyclic) onto p
017
018 double pvt_v[N]; // local
019
020 10
021 /* gaussian elimination with partial pivoting */
022 dgefa(double a[n][LDA],int lda, int n,int ipvt,int *info)
023 #pragma xmp align a[:] [i] with t(i)
024 {
025 15 REAL t;
026 int idamax(),j,k,kp1,l,nm1,i;
027 REAL x_pvt;
028
029 nm1 = n - 1;
030
031 20 for (k = 0; k < nm1; k++) {
032 kp1 = k + 1;
033 /* find l = pivot index */
034 l = A_idamax(k,n-k,a[k]);
035 ipvt[k] = l;
036
037 25 /* if (a[k][l] != ZERO) */
038 #ifdef XMP
039 #pragma xmp gmove
040 pvt_v[k:n-k] = a[l][k:n-k];
041
042 30 #else
043 for(i = k; i < n; i++) pvt_v[i] = a[i][l];
044 #endif
045
046 /* interchange if necessary */
047 35 if (l != k){
048 #ifdef XMP
049 #pragm xmp gmove
050 a[l][:] = a[k][:];
051
052 #pramga xmp gmove
053 40 a[k][:] = pvt_v[:];
054 #else
055 for(i = k; i < n; i++) a[i][l] = a[i][k];
056 for(i = k; i < n; i++) a[i][k] = pvt_v[i];
057

```

```

45 #endif
 }
 /* compute multipliers */
 t = -ONE/pvt_v[k];
 A_dscal(k+1, n-(k+1),t,a[k]);

50 /* row elimination with column indexing */
 for (j = kp1; j < n; j++) {
 t = pvt_v[j];
 A_daxpy(k+1,n-(k+1),t,a[k],a[j]);
 }
55 }
 ipvt[n-1] = n-1;
}

dgesl(double a[n][LDA],int lda,int n,int pvt[n],double b,int job)
60 #pragma xmp align a[:] [i] with t(i)
#pragma xmp align b[i] with t(i)
{
 REAL t;
 int k, kb, l, nm1;

65 nm1 = n - 1;
 /* job = 0 , solve a * x = b, first solve l*y = b */
 for (k = 0; k < nm1; k++) {
 l = ipvt[k];
70 #pragma xmp gmove
 t = b[l];
 if (l != k){
#pragma xmp gmove
 b[l] = b[k];
75 #pragma xmp gmove
 b[k] = t;
 }
 A_daxpy(k+1,n-(k+1),t,a[k],b);
 }

80 /* now solve u*x = y */
 for (kb = 0; kb < n; kb++) {
 k = n - (kb + 1);
#pragma xmp task on t(k)
85 {
 b[k] = b[k]/a[k][k];
 t = -b[k];
 }
#pragma xmp bcast (t) from t(k)
90 A_daxpy(0,k,t,a[k],b);
 }
}

```

001  
002  
003  
004  
005  
006  
007  
008  
009  
010  
011  
012  
013  
014  
015  
016  
017  
018  
019  
020  
021  
022  
023  
024  
025  
026  
027  
028  
029  
030  
031  
032  
033  
034  
035  
036  
037  
038  
039  
040  
041  
042  
043  
044  
045  
046  
047  
048  
049  
050  
051  
052  
053  
054  
055  
056  
057

```

001 /*
002 95 * distributed array based routine
003 */
004 A_daxpy(int b,int n,double da,double dx[n],double dy[n])
005 #pragma xmp align dx[i] with t(i)
006 #pragma xmp align dy[i] with t(i)
007
008 100 {
009 int i,ix,iy,m,mp1;
010 if(n <= 0) return;
011 if(da == ZERO) return;
012 /* code for both increments equal to 1 */
013
014 105 #pragma xmp loop on t(b+i)
015 for (i = 0;i < n; i++) {
016 dy[b+i] = dy[b+i] + da*dx[b+i];
017 }
018 }
019
020 110 int A_idamax(int b,int n,double dx[n])
021 #pragma xmp align dx[i] with t(i)
022 {
023 double dmax, g_dmax;
024
025 115 int i, ix, itemp;
026 if(n == 1) return(0);
027
028 /* code for increment equal to 1 */
029 itemp = 0;
030 dmax = 0.0;
031
032 120 #pragma xmp loop on t(i) reduction(lastmax:dmax/itemp/)
033 for (i = b; i < n; i++) {
034 if(fabs((double)dx[i]) > dmax) {
035 itemp = i;
036 125 dmax = fabs((double)dx[i]);
037 }
038 }
039 return (itemp);
040 }
041
042 130 A_dscal(int b,int n,double da,double dx[n])
043 #pragma xmp align dx[i] with t(i)
044 #pragma xmp align dy[i] with t(i)
045 {
046
047 135 int i;
048 if(n <= 0)return;
049
050 /* code for increment equal to 1 */
051
052 #pragma xmp loop on t(i)
053 140 for (i = b; i < n; i++)
054 dx[i] = da*dx[i];
055 }
056
057

```

# Index

- `/periodic/` modifier, 40
- address-of operator, 71
- `align`, 22
- align dummy variable, 23
- align offset, 23
- alignment, 10
- `array`, 38
- array assignment in XMP/C, 70
- array section in XMP/C, 69
- `async` clause, 48
- asynchronous communication, 11
- `barrier`, 43
- base language, 7
- base program, 7
- `bcast`, 46
- `block`, 20
- broadcast variables, 47
- coarray reference, 60
- collapse, 23
- collective mode (of `gmove`), 41
- combined directive, 15
- communication, 10
- construct, 8
- current executing node set, 4, 9
- current set of images, 11
- `cyclic`, 20
- data mapping, 8
- declarative directive, 8
- declarative directives, 13
- descriptor, 72
- descriptor association, 74, 77
- descriptor-of operator, 72, 85
- Directive
  - `align`, 22
  - `array`, 38
  - `async` clause, 48
  - `barrier`, 43
  - `bcast`, 46
  - `distribute`, 20
  - `gmove`, 41
  - `local_alias`, 61
  - `lock`, 66
  - `loop`, 31, 46
  - `nodes`, 15
  - `post`, 64, 65
  - `reduction`, 43
  - `reflect`, 39
  - `shadow`, 25
  - `task`, 27, 29
  - `tasks`, 28, 29
  - `template`, 18
  - `unlock`, 66
  - `wait`, 64, 65
  - `wait_async`, 47
- directive, 7, 13
- `distribute`, 20
- distribution, 10
- distribution format
  - `*`, 20
  - `block`, 20
  - `cyclic`, 20
  - `gblock`, 21
- entire node set, 9
- Example
  - `align`, 24, 111
  - `array`, 20, 38
  - array assignment in XMP/C, 71
  - array section in XMP/C, 70
  - `async`, 48
  - `barrier`, 18, 20
  - `bcast`, 18, 20
  - `coarray`, 60
  - coarray reference, 60
  - `distribute`, 18, 21, 111
  - dynamic allocation in XMP/C, 72
  - `end task`, 28, 29
  - `end tasks`, 29
  - `gmove`, 42
  - library interface, 109
  - `local_alias`, 62

001  
002  
003  
004  
005  
006  
007  
008  
009  
010  
011  
012  
013  
014  
015  
016  
017  
018  
019  
020  
021  
022  
023  
024  
025  
026  
027  
028  
029  
030  
031  
032  
033  
034  
035  
036  
037  
038  
039  
040  
041  
042  
043  
044  
045  
046  
047  
048  
049  
050  
051  
052  
053  
054  
055  
056  
057

- 001           loop, 18, 19, 33, 34, 111
- 002           memory-layout, 113
- 003           MPI interface, 106
- 004           node reference, 17
- 005           nodes, 16, 18, 21, 111
- 006           post, 65
- 007           procedure interface, 74, 79
- 008           reduction, 18, 20, 45
- 009           reflect, 40
- 010           shadow, 26, 40
- 011           task, 18, 19, 28, 29, 34, 35
- 012           tasks, 29
- 013           template, 19, 21, 111
- 014           template\_fix, 27, 63, 72
- 015           wait, 65
- 016           wait\_async, 48
- 017           xmp\_desc\_of, 72
- 018           xmp\_malloc, 72
- 019           executable directive, 8
- 020           executable directives, 13
- 021           executing node, 9
- 022           executing node array, 9
- 023           executing node set, 4, 9
- 024
- 025
- 026
- 027
- 028           full shadow, 25
- 029
- 030           gblock, 21
- 031           global, 8
- 032           global actual argument, 73
- 033           global communication constructs, 8
- 034           global construct, 8
- 035           global constructs, 4
- 036           global data, 4, 10
- 037           global dummy argument, 73
- 038           global-view model, 8
- 039           gmove, 41
- 040
- 041
- 042           image, 11
- 043           image index, 11
- 044           in mode (of gmove), 41
- 045           Intrinsic and Library Procedures
- 046                xmp\_all\_node\_num, 86
- 047                xmp\_all\_num\_nodes, 86
- 048                xmp\_array\_gtol, 108
- 049                xmp\_desc\_of, 85
- 050                xmp\_malloc, 72, 88
- 051                xmp\_node\_num, 86
- 052                xmp\_num\_nodes, 86
- 053                xmp\_test\_async, 87
- 054                xmp\_wtick, 87
- 055                xmp\_wtime, 87
- 056
- 057
- Laplace, 133
- library interface, 107
- Linpac, 134
- local, 8
- local actual argument, 73
- local alias, 11
- local data, 4, 10
- local dummy argument, 73
- local section, 10
- local-view model, 8
- local\_alias, 61
- location-variable, 33
- lock, 66
- loop, 31, 46
- node, 8
- node array, 9
- node number, 9
- node reference, 17
- node set, 9
- nodes, 15
- non-primary node array, 9
- out mode (of gmove), 41
- parent node set, 9
- post, 64, 65
- posting node, 64
- primary node array, 9
- primary node set, 4, 9
- procedure, 7
- procedure interface, 73
- reduction, 10
- reduction, 43
- reduction variable, 44
- reflect, 39
- reflection source, 25
- replicate, 23
- replicated data, 10
- replicated execution, 3
- Sample Program
  - Laplace, 133
  - Linpac, 134
- sequence association, 74
- shadow, 10
- shadow, 25
- shadow object, 25
- source node, 47
- structured block, 7
- synchronization, 10

- Syntax
  - align, 22
  - array, 38
  - array assignment in XMP/C, 70
  - array section in XMP/C, 69
  - barrier, 43
  - bcast, 47
  - coarray, 59
  - coarray reference, 60
  - directive, 13
  - distribute, 20
  - gmove, 41
  - local\_alias, 61
  - lock, 66
  - loop, 31
  - node reference, 17
  - nodes, 16
  - post, 64
  - reduction, 44
  - reflect, 39
  - shadow, 25
  - task, 27
  - tasks, 29
  - template, 18
  - template reference, 19
  - template\_fix, 26
  - wait, 65
  - wait\_async, 47
- task, 5, 10
- task, 27, 29
- tasks, 28, 29
- template, 8
- template, 18
- template reference, 19
- unlock, 66
- variable, 10
- wait, 64, 65
- wait\_async, 47
- waiting node, 65
- work mapping, 8
- work mapping constructs, 8
- XcalableMP C, 7
- XcalableMP Fortran, 7
- xmp\_align\_axis, 95
- xmp\_align\_offset, 96
- xmp\_align\_replicated, 96
- xmp\_align\_template, 97
- xmp\_all\_node\_num, 86
- xmp\_all\_num\_nodes, 86
- xmp\_array\_gtol, 108
- xmp\_array\_laddr, 109
- xmp\_array\_lbound, 98
- xmp\_array\_lead\_dim, 109
- xmp\_array\_lshadow, 97
- xmp\_array\_lsize, 108
- xmp\_array\_ndims, 97
- xmp\_array\_ubound, 99
- xmp\_array\_ushadow, 98
- xmp\_desc\_of, 85
- xmp\_desc\_of, 72, 85
- xmp\_dist\_axis, 95
- xmp\_dist\_blocksize, 93
- xmp\_dist\_gblockmap, 94
- xmp\_dist\_format, 93
- xmp\_dist\_nodes, 94
- xmp\_finalize\_mpi, 106
- xmp\_gather, 101
- xmp\_get\_mpi\_comm, 105
- xmp\_init\_mpi, 105
- xmp\_malloc, 72, 88
- xmp\_matmul, 102
- xmp\_node\_num, 86
- xmp\_nodes\_size, 89
- xmp\_nodes\_attr, 90
- xmp\_nodes\_equiv, 90
- xmp\_nodes\_index, 89
- xmp\_nodes\_ndims, 88
- xmp\_num\_nodes, 86
- xmp\_pack, 101
- xmp\_scatter, 101
- xmp\_sort\_down, 103
- xmp\_sort\_up, 103
- xmp\_template\_fixed, 91
- xmp\_template\_lbound, 92
- xmp\_template\_ndims, 91
- xmp\_template\_ubound, 92
- xmp\_test\_async, 87
- xmp\_transpose, 102
- xmp\_unpack, 102
- xmp\_wtick, 87
- xmp\_wtime, 87