

Unconfuse ERC check with powerflag helpers

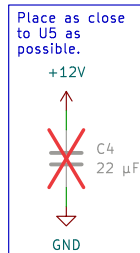
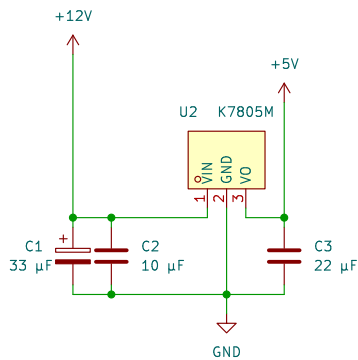

Sheet: /	
File: MHI-AC-CTRL.kicad_sch	
Title: MHI-AC-Ctrl	
Size: A4	Date: 2024-02-08T21:55:13+00:00
VCS: Git <a666bf6b2b01198b5c6356a4f1faa0860de0a3f9>	
KiCad E.D.A. kicad-cli 7.0.10-7.0.10-ubuntu23.04.1	Rev: a666bf6
	Id: 1/1