

LIMITED WARRANTY
EXCLUSION OF CERTAIN DAMAGES

The innopow UHF wireless microphone systems are warranted to be free from defects in material and workmanship for 12-month from the date of sale to the original purchaser.

Contact our Support@innopow.com.cn

Get additional 12-month warranty

Thanks for choosing us. Please read this instruction carefully and ensure the proper use of your system. We would not be liable if any damages happen because of improper use.

innopow

Email: support@innopow.com.cn

ADD: innopow Co. Ltd, Cheng jin fan, 3/f. Wan Feng 98 industrial town, Shajing Street Shen Zhen, Guang Dong 518100



innopow

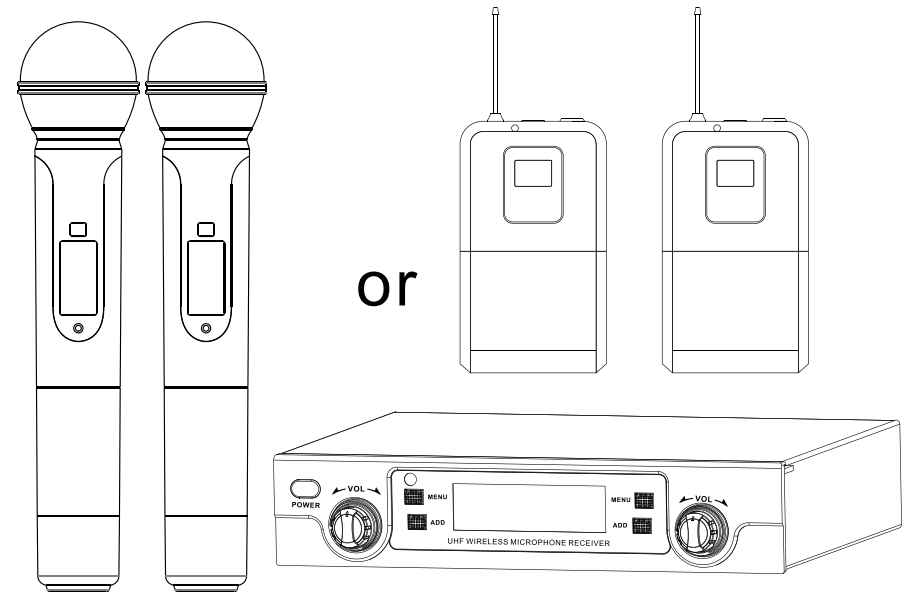

USER MANUAL

UHF WIRELESS MICROPHONE

SPECIFICATIONS

Wireless System

Carrier Frequency Range	UHF 535-575MHz (Depends on local regulations)
Frequency Stability	0.003%
Dynamic Range	>105dB
Frequency Response	50Hz-18KHz
Audio Output Level	1/4 interface: 0-500mV; XLR interface: 0-500mV
Working Distance	80Meter / 240ft
Operating Temperature	-10°C - 50°C

Dual Channel Wireless Receiver

Output impedance	XLR connector: 200 ohm
Channel	2 Channels
RF Sensitivity	-105 dBm
Image Rejection	>100 dB
Spurious Rejection	>90 dB
Dimensions	210mm X 160mm X 45mm
Weight	775g (27.3oz.)
Power	5W
Power Requirements	12-18 DC @ 400mA supplied by external power adapter

Handheld Transmitter

RF Transmitter Output	10mW, typical (varies by region)
Dimensions	249mm X 51mm dia. (9.8 X 2 in.)
Weight	360g (10.8 oz.) (without batteries)
Power Requirements	2 AA batteries, alkaline
Battery Life	About 16 hours by using original battery

Bodypack Transmitter

RF Transmitter Output	10mW, typical (varies by region)
Dimensions	110mm X 65mm X 22mm
Weight	74g
Power Requirements	2 AA batteries, alkaline
Battery Life	About 16 hours by using original battery

New innopow WM-333 500MHz Frequencies

Receiver 1 Frequencies				Receiver 2 Frequencies			
0-1	535.300	2-1	545.300	0-1	555.300	2-1	565.300
0-2	535.800	2-2	545.800	0-2	555.800	2-2	565.800
0-3	536.300	2-3	546.300	0-3	556.300	2-3	566.300
0-4	536.800	2-4	546.800	0-4	556.800	2-4	566.800
0-5	537.300	2-5	547.300	0-5	557.300	2-5	567.300
0-6	537.800	2-6	547.800	0-6	557.800	2-6	567.800
0-7	538.300	2-7	548.300	0-7	558.300	2-7	568.300
0-8	538.800	2-8	548.800	0-8	558.800	2-8	568.800
0-9	539.300	2-9	549.300	0-9	559.300	2-9	569.300
1-0	539.800	3-0	549.800	1-0	559.800	3-0	569.800
1-1	540.300	3-1	550.300	1-1	560.300	3-1	570.300
1-2	540.800	3-2	550.800	1-2	560.800	3-2	570.800
1-3	541.300	3-3	551.300	1-3	561.300	3-3	571.300
1-4	541.800	3-4	551.800	1-4	561.800	3-4	571.800
1-5	542.300	3-5	552.300	1-5	562.300	3-5	572.300
1-6	542.800	3-6	552.800	1-6	562.800	3-6	572.800
1-7	543.300	3-7	553.300	1-7	563.300	3-7	573.300
1-8	543.800	3-8	553.800	1-8	563.800	3-8	573.800
1-9	544.300	3-9	554.300	1-9	564.300	3-9	574.300
2-0	544.800	4-0	554.800	2-0	564.800	4-0	574.800

All the frequencies are under the new FCC Rules.



**ATTENTION
RISQUE D'ELECTROCUTION!
NE PAS OUVRIER!**

CAUTION: TO REDUCE THE RISK OF ELECTRIC SHOCK, DO NOT REMOVE COVER (OR BACK). NO USER-SERVICEABLE PARTS INSIDE. REFER SERVICING TO QUALIFIED SERVICE PERSONNEL



This lightning flash with arrowhead symbol within an equilateral triangle is intended to alert the user to the presence of non-insulated "dangerous voltage" within the product's enclosure that may be of sufficient magnitude to constitute a risk of electric shock.



The exclamation point within an equilateral triangle is intended to alert the user to the presence of important operating and maintenance instructions in the literature accompanying the appliance.

WARNING

TO PREVENT FIRE OR SHOCK HAZARD. DO NOT USE THIS PLUG WITH AN EXTENSION CORD, RECEPTACLE OR OTHER OUTLET UNLESS THE BLADES CAN BE FULLY INSERTED TO PREVENT BLADE EXPOSURE. TO PREVENT FIRE OR SHOCK HAZARD. DO NOT EXPOSE THIS APPLIANCE TO RAIN OR MOISTURE. TO PREVENT ELECTRICAL SHOCK, MATCH WIDE BLADE PLUG TO WIDE SLOT AND FULLY INSERT.

Important Safety Information

Read these instructions.

1. Keep these instructions.
2. Heed all warnings.
3. Follow all instructions.
4. Do not use this apparatus near water.
5. Clean only with dry cloth.
6. Do not block any ventilation openings. Install in accordance with the manufacturer's instructions.
7. Do not install near any heat sources such as radiators, heat registers, stoves, or other apparatus (including amplifiers) that produce heat.
8. Do not defeat the safety purpose of the polarized or grounding type plug. A polarized plug has two blades with one wider than the other. A grounding type plug has two blades and a third grounding prong. The wide blade or the third prong are provided for your safety. If the provided plug does not fit into your outlet, consult an electrician for replacement of the obsolete outlet.
9. Protect the power cord from being walked on or pinched particularly at the plugs, convenience receptacles, and at the point where they exit from the apparatus.
10. Only use attachments/accessories specified by the manufacturer.
11. Use only with the cart, stand, tripod, bracket, or table specified by the manufacturer, or sold with the apparatus. When a cart is used, use caution when moving the cart/apparatus combination to avoid injury from tip-over.
12. Unplug the apparatus during lightning storms, or when unused for long periods of time.
13. Refer all servicing to qualified personnel. Service is required when the apparatus has been damaged in any way, such as power supply cord or plug is damaged, liquid has been spilled or objects have fallen into the apparatus has been exposed to rain or moisture, does not operate normally, or has been dropped.
14. This appliance shall not be exposed to dripping or splashing water and that no object filled with liquid such as vases shall be placed on the apparatus.
15. Caution-to prevent electrical shock, match wide blade plug wide slot fully insert.
16. Please keep a good ventilation environment around the entire unit.
17. The direct plug-in adapter is used as disconnect device, the disconnect device shall remain readily operable.

Batteries (battery pack or batteries installed) shall not be exposed to excessive heat such as sunshine, fire or the like.



COMMON PROBLEMS AND TREATMENT METHOD

PHENOMENON	REASON	SOLUTION
Microphone doesn't work	The AA battery is not installed correctly	Check polarity label and install batteries correctly
	Battery is in the low level	Replace batteries
	The mic is defective	Contact support@innopow.com.cn ask for warranty
Signal cut-in and cut-out	Both mics are on the same frequency channel, e.g. M1cs one/two are both 645.30	Change the frequency on one mic
	Interference on the frequency channel	Change the frequency and test it for 3 minutes
	Hand mic is defective	Contact support@innopow.com.cn ask for warranty
Indicator light flashed	Battery is low	Replace batteries
Receiver LED display does not light up	The outlet is not power on	Confirm the AC power is normal, and confirm the supply voltage is normal
	Receiver power is not connected	Verify that one end of the AC power adapter is plugged into the power outlet and the other end is plugged into the power jack on the rear panel of the receiver
The receiver does not receive any signal	The wireless microphone is not turned on	Turn on the wireless microphone
	The microphone does not match the receiver frequency	Check whether the receiver and the transmitter use the same frequency and whether they are synchronized
	Microphone exceeds effective operation range	Check effective operation range and use the microphone within it.
The receiver receives signal but the transmitter has no sound	The battery in the wireless microphone is weak	Replace the battery
	Audio cables and equipments are not connected correctly	Check and correctly connect all the audio cables
The receiver has signal when the microphone is not open, and the speaker has noise	There are other devices in the vicinity of the same or similar frequency	Change the system position to avoid interference, so that the receiver and other electronics devices like computer or cell phone in use maintain adequate distance
A howling noise heard from the speaker	The distance between the microphone and the speakers is too closed	Move the microphone away from the speakers or change the direction of the microphone
The sound breaks or distorts when in use	Exceeds effective operation range	Check effective operation range and use the microphone within it.
Effective operation range is shortened	Environment is too complex, check the SQL value settings	Avoid overly complex environments. If there are large metal objects or walls between microphones and receiver, it will greatly affect the effective distance. Please adjust the SQL value

9.Sync bodypack transmitter to receiver.

(9a)Locate the window housing infrared(under battery cover)



(9b)From a close proximity(6 inches)point the infrared windows towards the infrared sensor next to Left'MENU' button.Press the 'MENU' button.within a few seconds the transmitter group/channel and frequency will match the receiver



10.Power ON/OFF/Mute feature.

Press the power button to mute. Press and hold the power button to ON/OFF

INTRODUCTION

Thank you for purchasing a innopow UHF Wireless Microphone System. This is 40 frequencies Channels system,ideal for church wedding small party and other scene.

PACKAGE CONTENT

- Receiver with LCD screen display,volume knob switch
- 2*Antennas
- DC power adapter (13.5v,600mA)
- 1/4" audio cable with 1/4"to 3.5mm audio adapter
- 4*AA Alkaline
- Optional
 - a. 2*Handheld microphone transmitters
 - b. 2*Bodypack transmitters, with 2* lapel& 1 headset mics

SYSTEM FEATURES

WM-333 RECEIVER

- Working range: up to 200 ft
- Battery Life: 15 Hours by using original AA battery
- 40 UHF frequencies channels each
- Dual rear panel permanently swivel antennas
- Front panel with LCD displays, Channel with frequency, transfer status RF/AF level
- Back panel with fixed Balanced XLR 1/4" jacks, audio line outputs and DC input jack
- Externally powered with included DC adapter(13.5V,600mA)

WM-333 HANDHELD MIC TRANSMITTER

- Sleek metal housing with internal antenna for optimum aesthetics and durable long life
- Unidirectional neodymium dynamic cartridge for optimum true sound, maximum feedback rejection and minimal handling noise
- 40 frequency channels
- Power On/Off.
- Status LCD display for frequency channel and battery level
- Convenient, economical operation with two AA alkaline batteries

WM-333B Bodypack Lap&Headset MIC TRANSMITTER

- Unidirectional neodymium Condenser cartridge for optimum true sound, maximum feedback rejection and minimal handling noise
- 40 frequency Channels Each
- Power On/Off.
- LCD display for frequency channel and battery level
- Convenient, economical operation with two AA alkaline batteries

DUAL CHANNEL RECEIVER FUNCTION

Front panel

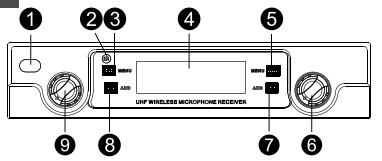

- 1 Power Switch
- 2 IR connect (play to the infrared transmitter signal to the frequency synhronization)
- 3 CHA menu Setting switch button
- 4 LED Display
- 5 CHB menu Setting switch button
- 6 CHA volume adjust
- 7 Incremental CHA button
- 8 Incremental CHB button
- 9 CHB volume adjust

Back panel

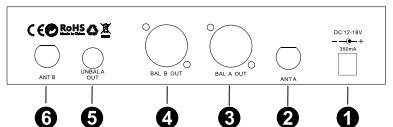

- 1 (DC) power input
- 2 A receiving antenna jack
- 3 CHA-channel balanced (XLR) output audio jack
- 4 CHB-channel balanced (XLR) output audio jack
- 5 CHA channel 1/4 inch audio output jack
- 6 B receiving antenna jack

WM333 HANDHELD MIC TRANSMITTER

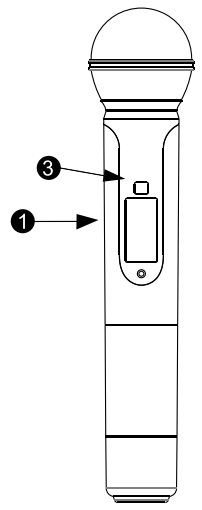

Function

- 1 LED Display
- 2 Battery cover
- 3 Infrared Connect (Receives infrared beam to synchronize frequencies)
- 5 Power Switch

HOW TO CHANGE THE FREQUENCY.

7. On receiver, (7a) press 'MENU' button twice to trigger the channel group choosing.

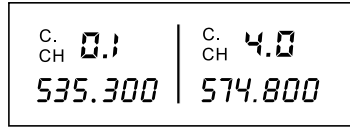

7a (7b) press 'ADD' button to change the frequency channel (7c) press 'MENU' button to trigger the sync process

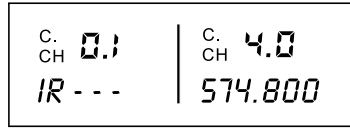

8. Sync handheld transmitter to receiver.



(8a) Locate the window housing infrared (8b) From a close proximity (6 inches) point the infrared windows towards the infrared sensor next to Left 'MENU' button. Press the 'MENU' button. within a few seconds the transmitter group/channel and frequency will match the receiver



4. Connect receiver to mixer or amplifier. Make sure audio levels on the mixer are muted or off. For PA System, use the 1/4" AF output (line level unbalanced, 4b). For all other applications use the XLR output (mic level, 4a)



5. Turn on transmitter

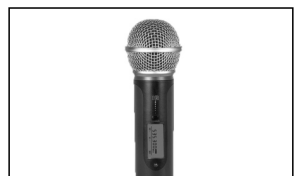
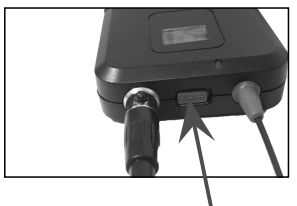

6. Turn on receiver

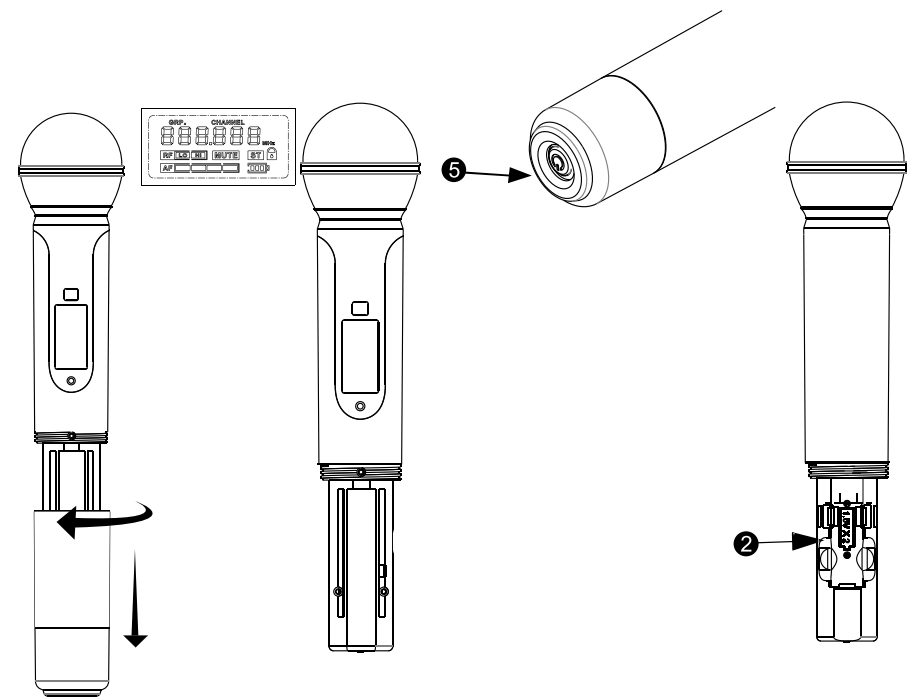
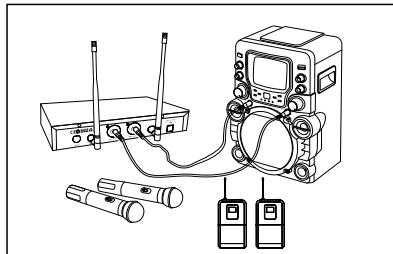
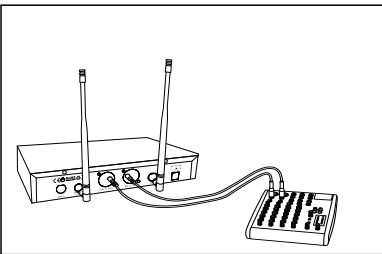
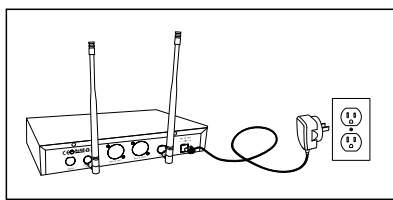
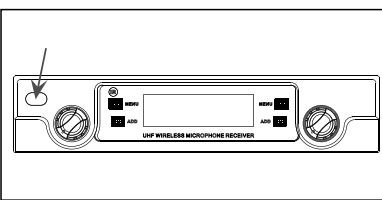

1. Microphone Battery Installation

Install batteries by unscrewing the BATTERY COMPARTMENT COVER counterclockwise and remove, Insert two fresh AA ALKALINE BATTERIES. Observing the correct polarity, and screw the cover back on the microphone. Fresh alkaline batteries can last up to 15 hours in use (depends on battery quality) But in order to ensure optimum performance, it is recommended that you replace the batteries when the Battery level is one frame.

2. Operating the WM333 Handheld MIC transmitter

Turn on the WM333 by clicking the Power Button (on the bottom of the mics) and press for 3 secs (Mic is on, click Power button is Mute or Unmute, Press and hold for 3 secs is On or Off)

The LCD screen will be on.

The microphone is now ready to use.

(Note: Observe care in selecting P.A volume, transmitter location and speaker placement so that acoustic feedback (howling or screeching will be avoided.)

BODYPACK

The innopow UHF Bodypack is to be used with the lavalier & headsets microphone with mini xlr connector

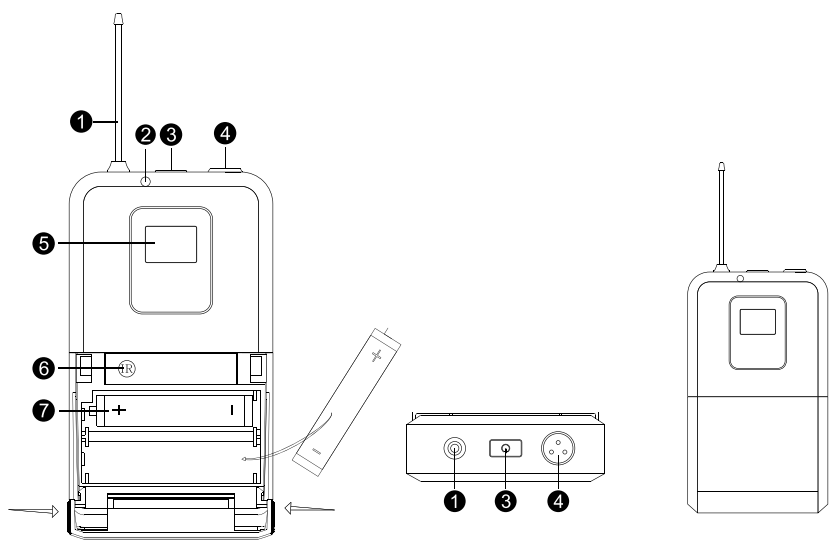

- ① Antenna
- ② Operating mode indicator
- ③ ON/MUTE/OFF button
- ④ Microphone input
- ⑤ LCD display screen
- ⑥ IR window(Play to the infrared transmitter signal to the frequency synchronization)
- ⑦ Battery compartment

QUICH SET UP GUIDE

Follow these instructions to get up and running in very little time.

1.Install 2 AA batteries.in the handheld transmitter and bodypack.Refer to the diagrams on the equipment to ensure batteries are positioned correctly.

Alert:incorrect installation might cause burn the microphone transmitter.

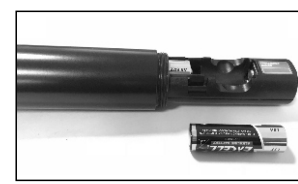

2.**Attach antennas** to the back of the receiver.Keep antenna straight while screwing it into the connector(2a).After attached.bend antennas into position(2b)



3.Connect power supply. Plug in the DC power supply(110-240V, DC 13.5V 600mA)

