



grass valley

A **BELDEN** BRAND

# K-FRAME

KAYENNE/KARRERA/GV KORONA

Video Production Center

## Installation & Service Manual

071896401

11/8/16

[www.grassvalley.com](http://www.grassvalley.com)

### Copyright and Trademark Notice

Copyright © 2016, Grass Valley USA, LLC. All rights reserved.

Belden, Belden Sending All The Right Signals, and the Belden logo are trademarks or registered trademarks of Belden Inc. or its affiliated companies in the United States and other jurisdictions. Grass Valley, K-Frame, Kayenne, Karrera, and GV Korona are trademarks or registered trademarks of Grass Valley USA, LLC. Belden Inc., Grass Valley USA, LLC, and other parties may also have trademark rights in other terms used herein.

## Terms and Conditions

Please read the following terms and conditions carefully. By using K-Frame Video Production Switcher documentation, you agree to the following terms and conditions.

Grass Valley hereby grants permission and license to owners of K-Frame Video Production Switchers to use their product manuals for their own internal business use. Manuals for Grass Valley products may not be reproduced or transmitted in any form or by any means, electronic or mechanical, including photocopying and recording, for any purpose unless specifically authorized in writing by Grass Valley.

A Grass Valley manual may have been revised to reflect changes made to the product during its manufacturing life. Thus, different versions of a manual may exist for any given product. Care should be taken to ensure that one obtains the proper manual version for a specific product serial number.

Information in this document is subject to change without notice and does not represent a commitment on the part of Grass Valley.

Warranty information is available in the Support section of the Grass Valley Web site ([www.grassvalley.com](http://www.grassvalley.com)).

## Important Safeguards and Notices

<i>Symbols and Their Meanings</i> .....	<i>vi</i>
<i>Warnings</i> .....	<i>vii</i>
<i>Cautions</i> .....	<i>vii</i>

This section provides important safety guidelines for operators and service personnel. Specific warnings and cautions appear throughout the manual where they apply. Please read and follow this important information, especially those instructions related to the risk of electric shock or injury to persons.

## Symbols and Their Meanings

*Important Safeguards and Notices* ..... v



Indicates that dangerous high voltage is present within the equipment enclosure that may be of sufficient magnitude to constitute a risk of electric shock.



Indicates that the user, operator or service technician should refer to the product manuals for important operating, maintenance, or service instructions.



This is a prompt to note the fuse rating when replacing fuses. The fuse referenced in the text must be replaced with one having the ratings indicated.



Identifies a protective grounding terminal which must be connected to earth ground prior to making any other equipment connections.

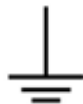

Identifies an external protective grounding terminal which may be connected to earth ground as a supplement to an internal grounding terminal.



Indicates that static sensitive components are present, which may be damaged by electrostatic discharge. Use anti-static procedures, equipment and surfaces during servicing.



Indicates that the equipment has more than one power supply cord, and that all power supply cords must be disconnected before servicing to avoid electric shock.



The presence of this symbol in or on Grass Valley equipment means that it has been tested and certified as complying with applicable Canadian Standard Association (CSA) regulations and recommendations for USA/Canada.



The presence of this symbol in or on Grass Valley equipment means that it has been tested and certified as complying with applicable Underwriters Laboratory (UL) regulations and recommendations for USA/Canada.



The presence of this symbol in or on Grass Valley equipment means that it has been tested and certified as complying with applicable Intertek Testing Services regulations and recommendations for USA/Canada.



The presence of this symbol in or on Grass Valley product means that it complies with all applicable European Union (CE) directives.



The presence of this symbol in or on Grass Valley product means that it complies with safety of laser product applicable standards.

## Warnings

*Important Safeguards and Notices* ..... v



A warning indicates a possible hazard to personnel, which may cause injury or death. Observe the following general warnings when using or working on this equipment:

- Appropriately listed/certified mains supply power cords must be used for the connection of the equipment to the mains voltage at either 120 V AC or 240 V AC.
- This product relies on the building's installation for short-circuit (over-current) protection. Ensure that a fuse or circuit breaker for 120 V AC or 240 V AC is used on the phase conductors.
- Any instructions in this manual that require opening the equipment cover or enclosure are for use by qualified service personnel only.
- Do not operate the equipment in wet or damp conditions.
- This equipment is grounded through the grounding conductor of the power cords. To avoid electrical shock, plug the power cords into a properly wired receptacle before connecting the equipment inputs or outputs.
- Route power cords and other cables so they are not likely to be damaged. Properly support heavy cable bundles to avoid connector damage.
- Disconnect power before cleaning the equipment. Do not use liquid or aerosol cleaners; use only a damp cloth.
- Dangerous voltages may exist at several points in this equipment. To avoid injury, do not touch exposed connections and components while power is on.
- High leakage current may be present. Earth connection of product is essential before connecting power.
- Prior to servicing, remove jewelry such as rings, watches, and other metallic objects.
- To avoid fire hazard, use only the fuse type and rating specified in the service instructions for this product, or on the equipment.
- To avoid explosion, do not operate this equipment in an explosive atmosphere.
- Use proper lift points. Do not use door latches to lift or move equipment.
- Avoid mechanical hazards. Allow all rotating devices to come to a stop before servicing.
- Have qualified service personnel perform safety checks after any service.

## Cautions

*Important Safeguards and Notices* ..... v





A caution indicates a possible hazard to equipment that could result in equipment damage. Observe the following cautions when operating or working on this equipment:

- This equipment is meant to be installed in a restricted access location.
- When installing this equipment, do not attach the power cord to building surfaces.
- Products that have no on/off switch, and use an external power supply must be installed in proximity to a main power outlet that is easily accessible.
- Use the correct voltage setting. If this product lacks auto-ranging power supplies, before applying power ensure that each power supply is set to match the power source.
- Provide proper ventilation. To prevent product overheating, provide equipment ventilation in accordance with the installation instructions.
- Do not operate with suspected equipment failure. If you suspect product damage or equipment failure, have the equipment inspected by qualified service personnel.
- To reduce the risk of electric shock, do not perform any servicing other than that contained in the operating instructions unless you are qualified to do so. Refer all servicing to qualified service personnel. Servicing should be done in a static-free environment.
- This unit may have more than one power supply cord. Disconnect all power supply cords before servicing to avoid electric shock.
- Follow static precautions at all times when handling this equipment.

Title                    K-Frame Kayenne/Karrera/Korona Installation & Service Manual  
Part Number        071896401  
Revision             8 November 2016, 3:01 pm

## Important Safeguards and Notices

<i>Symbols and Their Meanings</i> .....	<i>vi</i>
<i>Warnings</i> .....	<i>vii</i>
<i>Cautions</i> .....	<i>vii</i>

This section provides important safety guidelines for operators and service personnel. Specific warnings and cautions appear throughout the manual where they apply. Please

read and follow this important information, especially those instructions related to the risk of electric shock or injury to persons.

## Symbols and Their Meanings

*Important Safeguards and Notices* ..... v



Indicates that dangerous high voltage is present within the equipment enclosure that may be of sufficient magnitude to constitute a risk of electric shock.



Indicates that the user, operator or service technician should refer to the product manuals for important operating, maintenance, or service instructions.



This is a prompt to note the fuse rating when replacing fuses. The fuse referenced in the text must be replaced with one having the ratings indicated.



Identifies a protective grounding terminal which must be connected to earth ground prior to making any other equipment connections.



Identifies an external protective grounding terminal which may be connected to earth ground as a supplement to an internal grounding terminal.



Indicates that static sensitive components are present, which may be damaged by electrostatic discharge. Use anti-static procedures, equipment and surfaces during servicing.



Indicates that the equipment has more than one power supply cord, and that all power supply cords must be disconnected before servicing to avoid electric shock.



The presence of this symbol in or on Grass Valley equipment means that it has been tested and certified as complying with applicable Canadian Standard Association (CSA) regulations and recommendations for USA/Canada.



The presence of this symbol in or on Grass Valley equipment means that it has been tested and certified as complying with applicable Underwriters Laboratory (UL) regulations and recommendations for USA/Canada.



The presence of this symbol in or on Grass Valley equipment means that it has been tested and certified as complying with applicable Intertek Testing Services regulations and recommendations for USA/Canada.



The presence of this symbol in or on Grass Valley product means that it complies with all applicable European Union (CE) directives.



The presence of this symbol in or on Grass Valley product means that it complies with safety of laser product applicable standards.

## Warnings

*Important Safeguards and Notices* ..... v



A warning indicates a possible hazard to personnel, which may cause injury or death. Observe the following general warnings when using or working on this equipment:

- Appropriately listed/certified mains supply power cords must be used for the connection of the equipment to the mains voltage at either 120 V AC or 240 V AC.
- This product relies on the building's installation for short-circuit (over-current) protection. Ensure that a fuse or circuit breaker for 120 V AC or 240 V AC is used on the phase conductors.
- Any instructions in this manual that require opening the equipment cover or enclosure are for use by qualified service personnel only.
- Do not operate the equipment in wet or damp conditions.
- This equipment is grounded through the grounding conductor of the power cords. To avoid electrical shock, plug the power cords into a properly wired receptacle before connecting the equipment inputs or outputs.
- Route power cords and other cables so they are not likely to be damaged. Properly support heavy cable bundles to avoid connector damage.
- Disconnect power before cleaning the equipment. Do not use liquid or aerosol cleaners; use only a damp cloth.
- Dangerous voltages may exist at several points in this equipment. To avoid injury, do not touch exposed connections and components while power is on.
- High leakage current may be present. Earth connection of product is essential before connecting power.
- Prior to servicing, remove jewelry such as rings, watches, and other metallic objects.
- To avoid fire hazard, use only the fuse type and rating specified in the service instructions for this product, or on the equipment.
- To avoid explosion, do not operate this equipment in an explosive atmosphere.
- Use proper lift points. Do not use door latches to lift or move equipment.
- Avoid mechanical hazards. Allow all rotating devices to come to a stop before servicing.
- Have qualified service personnel perform safety checks after any service.

## Cautions

*Important Safeguards and Notices* ..... v



A caution indicates a possible hazard to equipment that could result in equipment damage. Observe the following cautions when operating or working on this equipment:

- This equipment is meant to be installed in a restricted access location.
- When installing this equipment, do not attach the power cord to building surfaces.
- Products that have no on/off switch, and use an external power supply must be installed in proximity to a main power outlet that is easily accessible.
- Use the correct voltage setting. If this product lacks auto-ranging power supplies, before applying power ensure that each power supply is set to match the power source.
- Provide proper ventilation. To prevent product overheating, provide equipment ventilation in accordance with the installation instructions.
- Do not operate with suspected equipment failure. If you suspect product damage or equipment failure, have the equipment inspected by qualified service personnel.
- To reduce the risk of electric shock, do not perform any servicing other than that contained in the operating instructions unless you are qualified to do so. Refer all servicing to qualified service personnel. Servicing should be done in a static-free environment.
- This unit may have more than one power supply cord. Disconnect all power supply cords before servicing to avoid electric shock.
- Follow static precautions at all times when handling this equipment.

## Electrostatic Discharge (ESD) Protection



Electrostatic discharge occurs when electronic components are improperly handled and can result in intermittent failure or complete damage adversely affecting an electrical circuit. When you remove and replace any card from a frame always follow ESD-prevention procedures:

- Ensure that the frame is electrically connected to earth ground through the power cord or any other means if available.
- Wear an ESD wrist strap ensuring that it makes good skin contact. Connect the grounding clip to an *unpainted surface* of the chassis frame to safely ground unwanted ESD voltages. If no wrist strap is available, ground yourself by touching the *unpainted* metal part of the chassis.
- For safety, periodically check the resistance value of the antistatic strap, which should be between 1 and 10 megohms.
- When temporarily storing a card make sure it is placed in an ESD bag.
- Cards in an earth grounded metal frame or casing do not require any special ESD protection.

## Battery Handling



This product includes a backup battery. There is a danger of explosion if the battery is replaced incorrectly. Replace the battery only with the same or equivalent type recommended by the manufacturer. Dispose of used batteries according to the

manufacturer's instructions. Before disposing of your Grass Valley equipment, please review the *Disposal and Recycling Information* appendix.

## Cautions for LCD and TFT Displays



Excessive usage may harm your vision. Rest for 10 minutes for every 30 minutes of usage.

If the LCD or TFT glass is broken, handle glass fragments with care when disposing of them. If any fluid leaks out of a damaged glass cell, be careful not to get the liquid crystal fluid in your mouth or skin. If the liquid crystal touches your skin or clothes, wash it off immediately using soap and water. Never swallow the fluid. The toxicity is extremely low but caution should be exercised at all times.

## Mesures de sécurité et avis importants

*Signification des symboles utilisés* ..... ix

*Avertissements* ..... x

*Mises en garde* ..... xi

La présente section fournit des consignes de sécurité importantes pour les opérateurs et le personnel de service. Des avertissements ou mises en garde spécifiques figurent dans le manuel, dans les sections où ils s'appliquent. Prenez le temps de bien lire les consignes et assurez-vous de les respecter, en particulier celles qui sont destinées à prévenir les décharges électriques ou les blessures.

## Signification des symboles utilisés



Signale la présence d'une tension élevée et dangereuse dans le boîtier de l'équipement ; cette tension peut être suffisante pour constituer un risque de décharge électrique.



Avertit l'utilisateur, l'opérateur ou le technicien de maintenance que des instructions importantes relatives à l'utilisation et à l'entretien se trouvent dans la documentation accompagnant l'équipement.



Invite l'utilisateur, l'opérateur ou le technicien de maintenance à prendre note du calibre du fusible lors du remplacement de ce dernier. Le fusible auquel il est fait référence dans le texte doit être remplacé par un fusible du même calibre.



Identifie une borne de mise à la terre de protection. Il faut relier cette borne à la terre avant d'effectuer toute autre connexion à l'équipement.



Identifie une borne de mise à la terre externe qui peut être connectée en tant que borne de mise à la terre supplémentaire.



Signale la présence de composants sensibles à l'électricité statique et qui sont susceptibles d'être endommagés par une décharge électrostatique. Utilisez des procédures, des équipements et des surfaces antistatiques durant les interventions d'entretien.



Le symbole ci-contre signifie que l'appareil comporte plus d'un cordon d'alimentation et qu'il faut débrancher tous les cordons d'alimentation avant toute opération d'entretien, afin de prévenir les chocs électriques.



La marque C-CSA-US certifie que l'appareil visé a été testé par l'Association canadienne de normalisation (CSA) et reconnu conforme aux exigences applicables en matière de sécurité électrique en vigueur au Canada et aux États-Unis.



La marque C-UL-US certifie que l'appareil visé a été testé par Underwriters Laboratory (UL) et reconnu conforme aux exigences applicables en matière de sécurité électrique en vigueur au Canada et aux États-Unis.



La marque ETL Listed d'Intertek pour le marché Nord-Américain certifie que l'appareil visé a été testé par Intertek et reconnu conforme aux exigences applicables en matière de sécurité électrique en vigueur au Canada et aux États-Unis.



Le marquage CE indique que l'appareil visé est conforme aux exigences essentielles des directives applicables de l'Union européenne en matière de sécurité électrique, de compatibilité électromagnétique et de conformité environnementale.



Le symbole ci-contre sur un appareil Grass Valley ou à l'intérieur de l'appareil indique qu'il est conforme aux normes applicables en matière de sécurité laser.

## Avertissements

*Mesures de sécurité et avis importants* ..... ix



Les avertissements signalent des conditions ou des pratiques susceptibles d'occasionner des blessures graves, voire fatales. Veuillez vous familiariser avec les avertissements d'ordre général ci-dessous :

- Un cordon d'alimentation dûment homologué doit être utilisé pour connecter l'appareil à une tension de secteur de 120 V CA ou 240 V CA.
- La protection de ce produit contre les courts-circuits (surintensités) dépend de l'installation électrique du bâtiment. Assurez-vous qu'un fusible ou un disjoncteur pour 120 V CA ou 240 V CA est utilisé sur les conducteurs de phase.
- Dans le présent manuel, toutes les instructions qui nécessitent d'ouvrir le couvercle de l'équipement sont destinées exclusivement au personnel technique qualifié.
- N'utilisez pas cet appareil dans un environnement humide.
- Cet équipement est mis à la terre par le conducteur de mise à la terre des cordons d'alimentation. Pour éviter les chocs électriques, branchez les cordons d'alimentation sur une prise correctement câblée avant de brancher les entrées et sorties de l'équipement.

- Acheminez les cordons d'alimentation et autres câbles de façon à ce qu'ils ne risquent pas d'être endommagés. Supportez correctement les enroulements de câbles afin de ne pas endommager les connecteurs.
- Coupez l'alimentation avant de nettoyer l'équipement. Ne pas utiliser de nettoyeurs liquides ou en aérosol. Utilisez uniquement un chiffon humide.
- Des tensions dangereuses peuvent exister en plusieurs points dans cet équipement. Pour éviter toute blessure, ne touchez pas aux connexions ou aux composants exposés lorsque l'appareil est sous tension.
- Avant de procéder à toute opération d'entretien ou de dépannage, enlevez tous vos bijoux (notamment vos bagues, votre montre et autres objets métalliques).
- Pour éviter tout risque d'incendie, utilisez uniquement les fusibles du type et du calibre indiqués sur l'équipement ou dans la documentation qui l'accompagne.
- Ne pas utiliser cet appareil dans une atmosphère explosive.
- Présence possible de courants de fuite. Un raccordement à la masse est indispensable avant la mise sous tension.
- Après tout travail d'entretien ou de réparation, faites effectuer des contrôles de sécurité par le personnel technique qualifié.

## Mises en garde

*Mesures de sécurité et avis importants* ..... ix



Les mises en garde signalent des conditions ou des pratiques susceptibles d'endommager l'équipement. Veuillez vous familiariser avec les mises en garde ci-dessous :

- L'appareil est conçu pour être installé dans un endroit à accès restreint.
- Au moment d'installer l'équipement, ne fixez pas les cordons d'alimentation aux surfaces intérieures de l'édifice.
- Les produits qui n'ont pas d'interrupteur marche-arrêt et qui disposent d'une source d'alimentation externe doivent être installés à proximité d'une prise de courant facile d'accès.
- Si l'équipement n'est pas pourvu d'un modules d'alimentation auto-adaptables, vérifiez la configuration de chacun des modules d'alimentation avant de les mettre sous tension.
- Assurez une ventilation adéquate. Pour éviter toute surchauffe du produit, assurez une ventilation de l'équipement conformément aux instructions d'installation.
- N'utilisez pas l'équipement si vous suspectez un dysfonctionnement du produit. Faites-le inspecter par un technicien qualifié.
- Pour réduire le risque de choc électrique, n'effectuez pas de réparations autres que celles qui sont décrites dans le présent manuel, sauf si vous êtes qualifié pour le faire. Confiez les réparations à un technicien qualifié. La maintenance doit se réaliser dans un milieu libre d'électricité statique.
- L'appareil peut comporter plus d'un cordon d'alimentation. Afin de prévenir les chocs électriques, débrancher tous les cordons d'alimentation avant toute opération d'entretien.

- Veillez à toujours prendre les mesures de protection antistatique appropriées quand vous manipulez l'équipement.

## Protection contre les décharges électrostatiques (DES)



Une décharge électrostatique peut se produire lorsque des composants électroniques ne sont pas manipulés de manière adéquate, ce qui peut entraîner des défaillances intermittentes ou endommager irrémédiablement un circuit électrique. Au moment de remplacer une carte dans un châssis, prenez toujours les mesures de protection antistatique appropriées :

- Assurez-vous que le châssis est relié électriquement à la terre par le cordon d'alimentation ou tout autre moyen disponible.
- Portez un bracelet antistatique et assurez-vous qu'il est bien en contact avec la peau. Connectez la pince de masse à une *surface non peinte* du châssis pour détourner à la terre toute tension électrostatique indésirable. En l'absence de bracelet antistatique, déchargez l'électricité statique de votre corps en touchant une surface métallique *non peinte* du châssis.
- Pour plus de sécurité, vérifiez périodiquement la valeur de résistance du bracelet antistatique. Elle doit se situer entre 1 et 10 mégohms.
- Si vous devez mettre une carte de côté, assurez-vous de la ranger dans un sac protecteur antistatique.
- Les cartes qui sont reliées à un châssis ou boîtier métallique mis à la terre ne nécessitent pas de protection antistatique spéciale.

## Remplacement et élimination des piles



L'appareil renferme une pile. Pour réduire le risque d'explosion, vérifiez la polarité et ne remplacez la pile que par une pile du même type, recommandée par le fabricant. Mettez les piles usagées au rebut conformément aux directives du fabricant. Avant de vous défaire de l'équipement, assurez-vous d'avoir lu l'appendice *Disposal and Recycling Information*.

## Précautions pour les écrans LCD et TFT



Regarder l'écran pendant une trop longue période de temps peut nuire à votre vision. Prenez une pause de 10 minutes, après 30 minutes d'utilisation.

Si l'écran LCD ou TFT est brisé, manipulez les fragments de verre avec précaution au moment de vous en débarrasser. veillez à ce que le cristal liquide n'entre pas en contact avec la peau ou la bouche. En cas de contact avec la peau ou les vêtements, laver immédiatement à l'eau savonneuse. Ne jamais ingérer le liquide. La toxicité est extrêmement faible, mais la prudence demeure de mise en tout temps.

## Recycling

Visit [www.grassvalley.com](http://www.grassvalley.com) for recycling information.



## Certification and Compliance

<i>Safety Compliance</i> .....	<i>xiii</i>
<i>Restriction on Hazardous Substances (RoHS)</i> .....	<i>xiii</i>
<i>Restriction on Hazardous Substances (RoHS)</i> .....	<i>xiii</i>
<i>Electromagnetic Compatibility</i> .....	<i>xiii</i>

### Safety Compliance

**Verify required content**, for your specific purposes, with Carlos Cohen or Daniel Lord. The applicable laboratory logo (**CSA mark** for Canada and the United States, vs. **UL mark** for Canada and the U.S.) appears in the DoC. **Adapt the text** where appropriate, depending on the number of power supply units included.



- This equipment complies with the requirements of CSA/UL/IEC/EN 60950-1, 2<sup>nd</sup> Ed. + AM1, Safety of information technology equipment.
- The power cords [cord] supplied with this equipment meet [meets] the appropriate national standards for the country of destination.

### Restriction on Hazardous Substances (RoHS)

To determine whether a **Restriction on Hazardous Substances (RoHS)** statement is required (and what the text should be) please contact Aurélien Hathout.

### Electromagnetic Compatibility



This equipment has been tested for verification of compliance with FCC Part 15, Subpart B requirements for class A digital devices.

---

**Note:** This equipment has been tested and found to comply with the limits for a Class A digital device, pursuant to Part 15 of the FCC rules. These limits are designed to provide reasonable protection against harmful interference when the equipment is operated in a commercial environment. This equipment generates, uses, and can radiate radio frequency energy, and, if not installed and used in accordance with the instruction manual, may cause harmful interference to radio communications. Operation of this equipment in a residential area is likely to cause harmful interference in which case the user will be required to correct the interference at his own expense.

---



This equipment has been tested and found to comply with the requirements of the EMC directive 2004/108/EC:

- EN 55022 Class A Radiated and conducted emissions
- EN 61000-3-2 Limits for harmonic current emissions
- EN 61000-3-3 Limitation of voltage fluctuations and flicker
- EN 61000-4-2 Electrostatic discharge immunity
- EN 61000-4-3 Radiated, radio-frequency, electromagnetic field immunity
- EN 61000-4-4 Electrical fast transient immunity
- EN 61000-4-5 Surge transient immunity

- EN 61000-4-6 Conducted disturbances immunity
- EN 61000-4-8 Power frequency magnetic field immunity
- EN 61000-4-11 Voltage dips, short interruptions and voltage variations immunity

# toc

## Table of Contents

<b>1 Introduction .....</b>	<b>1</b>
Overview.....	1
Features.....	1
General .....	1
K-Frame Standard Frame .....	2
K-Frame Compact Frame .....	2
K-Frame Compact S-series Frame (Differences) .....	3
K-Frame Video Processor .....	3
K-Frame Control Surfaces .....	4
Kayenne Control Surface .....	4
Karrera Control Surface .....	9
GV Korona Control Surfaces.....	12
Soft Panel (KSP) Option .....	14
Menu Application .....	14
Supported Control Protocols.....	15
<b>2 Control Surface Installation .....</b>	<b>17</b>
K-Frame Control Surfaces .....	17
Kayenne K-Frame Control Surfaces.....	17
Control Panel and Support Structure Assembly.....	17
Control Panel Variations .....	17
Control Panel Cooling .....	18
Truck and High Vibration Environment Considerations .....	18
4-ME 35 Control Panel, Curved Assembly.....	19
4-ME 35 Control Panel, Flat Assembly .....	20
4-ME 25 Control Panel .....	24
3-ME 35 Control Panel, Curved Assembly.....	25
3-ME 35 Control Panel, Flat Assembly .....	28
3-ME 25 Control Panel .....	30
2-ME 35 Control Panel, Curved Assembly.....	30
2-ME 35 Control Panel, Flat Assembly with Local Aux .....	33
2-ME 35 Control Panel, Flat without Local Aux.....	35
2-ME 25 Control Panel .....	36
1-ME 15 Control Panel .....	37
Separately Mounted Local Aux Stripe (35 & 25 Models) .....	38
Control Panel Stripe-PCU Connections .....	39
Touch Screen Menu Panel Installation.....	40
Karrera Control Surface .....	42
3-ME Karrera Control Panel Installation.....	43
2-ME Compact Karrera Control Panel Installation .....	46
PC Requirements .....	48

Macintosh Computer Operation .....	48
Hardware Installation.....	48
Menu on User PC Software Installation .....	48
User PC Configuration .....	49
Optional Touch Screen Menu Panel Installation .....	49
Menu Panel Dimensions .....	50
Menu Panel Connectors .....	51
Menu Panel Cooling .....	51
Fanless PC Dimensions and Connectors .....	52
Menu Panel Articulated Arm Installation .....	53
Menu Panel Hardware Installation With Articulated Arm .....	54
Wall Mounting Without Articulated Arm .....	54
Optional Local Aux Panel Installation.....	55
Local Aux 25 Panel Dimensions .....	56
GV Korona Control Surfaces.....	59
2-ME GV Korona Control Panel Dimensions.....	59
2-ME GV Korona Control Panel Cutout Dimensions .....	62
1-ME GV Korona Control Panel Dimensions.....	62
1-ME GV Korona Control Panel Cutout Dimensions .....	65

### **3 Frame Installation ..... 67**

Overview.....	67
Weight Distribution .....	67
Cooling Requirements.....	67
Power Connections.....	67
13-RU Video Processor Dimensions .....	68
13RU Video Processor Installation and Airflow .....	70
13RU Video Processor Views .....	70
6-RU Video Processor Dimensions.....	73
6RU Video Processor Installation and Airflow .....	75
6RU Compact S-series Front View with Doors Removed .....	75
6RU Compact Front Views with Doors Removed .....	76
6RU Video Processor Rear View .....	77
K-Frame Controller Connections .....	77
K-Frame Standard Power Supply Views.....	78
K-Frame Standard Power Supply Frame Rack Installation and Airflow.....	79
K-Frame Standard Power Supply Cooling.....	80
K-Frame Standard Power Supply AC Requirements .....	81
Supplied Power Cables for Standard K-Frame .....	81
About Low Line (120V) Operational Considerations.....	81
About High Line (208V-240V) Verses Low Line (120V) Operations .....	82
K-Frame Compact Power Supply AC Requirements .....	82
About Low Line (120V) Operational Considerations.....	82
About High Line (208V-240V) Verses Low Line (120V) Operations .....	83
Replacing Compact Power Supplies.....	83
K-Frame Video Processor Door Removal Clearance .....	84

<b>4</b>	<b>System Cabling</b>	<b>85</b>
	About the K-Frame System Cabling Section	85
	K-Frame System Cabling Overview	85
	K-Frame Ethernet Tally Verses Serial Tally	85
	Suites and Control Surfaces	85
	Network Cabling	85
	K-Frame Ethernet Switch	86
	Customer Supplied Ethernet Routers and Switches	86
	Factory Default Network Settings	87
	Kayenne K-Frame System Cabling	88
	Kayenne Network Cabling	88
	Kayenne Suites and Control Surfaces	89
	Kayenne Control Panel Cabling	91
	Kayenne ME and Local Aux Stripe Connections	91
	Kayenne Satellite Panel Cabling	92
	Kayenne Touch Screen Menu Panels (Used with PCU)	93
	Karrera K-Frame System Cabling	94
	Karrera Suites and Control Surfaces	94
	Karrera Control Panel Network Cabling	95
	Optional Touch Screen Menu Panel Cabling	95
	Optional Karrera Local Aux Panel Cabling	96
	GV Korona K-Frame System Cabling	98
	GV Korona Suites and Control Surfaces	98
	K-Frame Video Cabling	99
	Modular 10GigE IP I/O Fiber Optic Cabling	99
	Inputs	99
	Outputs	100
	Reference Input	100
	K-Frame System Video Timing and Delay	100
	Timing Analyzer	101
	Time Zones and the Autotiming Window	102
	ClipStore Cabling	103
	ClipStore Video Cabling	104
	Video Processor Frame GPI/Relay Tally Interface	106
	GPI and Relay Tally Connections	106
	GPI Inputs	107
	Relay Tally/GPI Outputs	108
	GPI In, GPI Out, Relay Tally Pin Assignments	110
	RS-422/485 Port Pin Assignments	113
	RS-232 Port Pin Assignments	113
<b>5</b>	<b>Basic Configuration</b>	<b>115</b>
	Introduction	115
	Configuration Steps	115
	K-Frame Configuration Data	115
	Eng Setup	116
	User Setups	116
	Network IPs and Node Settings	116

GV Switcher Menu Application.....	116
Menu Top Line .....	117
Data Pads and Touch Buttons.....	117
Data Pads and Soft Knobs.....	118
Menu Selection.....	118
Power Up and Initialize the System.....	118
Power and Initialization Indications .....	119
K-Frame Menu Application Initialization.....	119
Default K-Frame System Communications.....	119
Establishing Menu to Frame Communication.....	119
Connecting the Menu Application to a Frame .....	120
About Network Configuration .....	120
IP Address Background Information.....	120
Gateway IP Addresses .....	121
K-Frame Default IP Addresses On Isolated Network .....	121
Connecting to an Existing Network .....	121
Setting IPs with the K-Frame Switcher Installer Program .....	121
K-Frame System Names.....	122
Set IP Procedure Using the K-Frame Installer Program .....	123
Other K-Frame Switcher Installer Program Functions .....	124
Set the IPs Using Device Web Pages.....	125
Set the IP Video Configuration for SFP Gateway and Subnet Masks.....	126
Changing the Image Store IP Address .....	126
Changing Control Panel IP Addresses .....	126
Changing the Kayenne or Karrera Menu Panel IP Address.....	127
32-Crosspoint Remote Aux Panel IP Address.....	127
Restoring the Default IP Address.....	129
About the S25/S50 Remote Aux Panel Upgrade.....	130
Switcher Remote Aux Button Functionality.....	130
Install New S25/S50 Remote Aux Panel Software .....	131
Configure the Remote Aux Panel System.....	131
Configure the Remote Aux Panel Network.....	132
Connect the Remote Aux Panel to the Switcher IP Network .....	132
Delegate Control of a Switcher Aux Bus to the Remote Aux Panel .....	132
Map Switcher Sources to Remote Aux Bus Buttons .....	132
About Modular 10GigE IP I/O Address and Port Configuration.....	134
10GigE Modular I/O Modes .....	135
Transmit IP Addresses and UDP Ports .....	135
Local IP Addresses.....	135
Receive IP Addresses and UDP Ports .....	135
Configure 10GigE Modular I/O Mode.....	136
Configure 10GigE IP I/O Transmit IP Addresses and UDP Ports.....	136
Configure 10GigE IP I/O Receive IP Addresses and UDP Ports.....	136
Configure a 10GigE IP I/O Multicast Video Signal .....	137
Registering K-Frame System Nodes .....	137
Kayenne and Karrera Menu Panel Registration.....	137
K-Frame Control Panel Registration .....	138
Remote Aux Panel Registration .....	138
Control Panel Brightness Adjustment .....	139
Engineering Setups.....	140

Source Definition Inputs .....	140
Change Direct Source Definition .....	141
Source Naming Background Information.....	141
Engineering Names, Eng IDs, and Logical IDs .....	142
Alternative Source Names .....	142
Source Patch Feature .....	144
Output Assignments .....	145
Change Output Assignments .....	145
Configuring Aux Buses .....	147
About Passing/Blanking Ancillary Data for Individual Outputs.....	148
Configure Aux Output Blanking.....	148
Configure Fixed Output Blanking .....	149
ME Viewer.....	149
Switcher Relay Tally Configuration .....	150
About Relay Tally Systems .....	151
Switcher Relay Tally Calculator Menus.....	152
Creating an On Air Relay Tally Calculator Using MEs or PGM/PST .....	153
Create an On Air Relay Tally Calculator Using Aux Buses .....	154
Creating a Look Ahead Relay Tally Calculator .....	154
Creating a Bus Relay Tally Calculator .....	155
Relay Assign Menu .....	156
Assign Sources to Tally Relays.....	157
About MV Green Relay Tally Calculations for Multiviewer On-Air and Green .....	158
Configure MV Green Relay Tally for Look Ahead Preview .....	158
Ethernet Tally Configuration .....	158
Configure the On-Air Tally Program ME .....	159
Configure the GV Switcher Ethernet Tally System Interface.....	159
Set Source Names with External Ethernet Tally .....	160
ClipStore Configuration.....	161
Summit/Solo Software Version.....	161
Setting the Summit IP Address.....	161
Install the ClipStore License.....	162
Configure ClipStore as a Node .....	162
Configure Source Definitions .....	163
Configure Outputs .....	164
Acquire and Assign CS channels in another suite .....	164
ClipStore Config Menu .....	165
Assigning ClipStore Channel Resources to a Suite .....	166
Set the Summit/Solo IP Address.....	166
Configure the Remote Desktop Connection .....	166
4K Frame Operating Mode Configuration .....	171
System Requirements .....	171
4K Physical ME to logical ME Acquisitions .....	171
Configure a 4K Frame Operating Mode Video Setting.....	171
About Releasing Resources in 4K Mode .....	171
Configure a 4K Source Definition (Video Inputs) .....	172
Configure a 4K Key Source Definition (Key Inputs) .....	172
Configure a 4K Output.....	172
Camera Control with Ethernet Tally Configuration .....	173
Configure Node Settings .....	173

Configure Source Definitions .....	174
Acquire Resources.....	176
Switcher Ethernet Camera Tally .....	177
Tally Calc Menus .....	178
Color Assign Menu .....	178
User Setups .....	179
Configuration File Save and Load .....	179
File Storage Organization.....	181
K-Frame Drive Access.....	181
Eng Setup File Operations .....	182
Save Eng Setup Files.....	182
Load Eng Setup Files .....	183
Multiple Suite Resource Sharing .....	183
Collaborative Resource Sharing .....	183
Independent Resource Sharing .....	184
Suite .....	184
Control Surface.....	185
Logical Aux Buses .....	186
Remote Aux Panels.....	186
External Control Points .....	186
Setting Up Resource Sharing.....	186
Prepare Worksheet .....	187
Configure Control Surfaces .....	187
Define Default Multi-Suite Engineering Resources .....	188
Divide Resources Between Suites .....	188
Save Default Multi-Suite Engineering Setups File .....	190
Define and Save Default Suite Prefs .....	190
Define and Save Default Panel Prefs.....	190
Multi Suite Independent Operation .....	191
Engineering Login.....	191
SetDef and MatchDef.....	192
SetDef Output Conversion.....	193
MatchDef Input Conversion.....	194
Video Settings.....	195
Reference Sync Selection .....	195
Frame Operating Mode.....	196
ME Blanking Settings .....	196
Other Settings.....	196
Node Settings .....	197
Frame Suite Nodes & ID Menu .....	197
Mapping Logical Remote Aux Panels.....	198
Remote Aux Button Mapping .....	198
About the Status Menu .....	199
Acquire Resources.....	200
General Procedure to Acquire Resources .....	200
Acquire Multiviewer Resources with a Standard Frame .....	200
Acquire Multiviewer Resources with a Compact (Six-Keyer) Frame .....	202
Acquire Multiviewer Resources with a Compact S-series (Four-Keyer) Frame..	203



## **6 External Interfaces.....205**

Introduction.....	205
General External Device Interfacing .....	205
Ports & Devices.....	206
PBus Ports.....	206
Copy Trigger Names.....	207
GPI Outputs.....	208
PBus and GPI Enables.....	209
External Devices.....	211
VDCP Ethernet .....	212
VDCP on Ethernet Configuration.....	213
Device Definition.....	214
Create an External Device Definition .....	214
Ethernet Tally Ports.....	215
Configure Ethernet Tally Ports .....	215
Editor Ports .....	216
Router Interface .....	217
Router Source Name Changes (at the Router) and GV Switcher Updates .....	218
Features .....	219
Control Interface Cabling .....	219
Video Interface Cabling.....	219
External Routing System Configuration .....	219
Setting IP Addresses.....	219
Primary and Secondary Router Communications .....	220
Define Routed Source Definitions.....	221
User Setups .....	222

## **7 Maintenance.....223**

Introduction.....	223
Servicing Precautions.....	223
Grass Valley Web Site.....	223
Grass Valley Customer Support FAQ Database.....	223
Video Processor Frame Reset Procedure.....	223
Panel Control Unit (PCU) Reset (Kayenne only) .....	224
Kayenne Control Panel Adjustments .....	225
Kayenne Lever Arm Calibration .....	225
Calibrating the Joystick.....	225
ME Stripe Mapping .....	226
Karrera Control Panel Adjustments.....	227
Lever Arm Calibration .....	227
Karrera Joystick Calibration .....	229
Karrera Panel Saver Time Adjustment .....	231
Kayenne and Karrera Touchscreen Calibration.....	232
GV Korona Control Panel Adjustments .....	234
GV Korona Lever Arm Calibration .....	234
GV Korona Joystick Calibration.....	236
GV Korona Panel Saver Time Adjustment.....	237
Software Installation.....	238

Software Option Authorization .....	238
Authorization Codes .....	238
Expiration Dates .....	238
Authorization Procedure .....	239
Control Panel Web Pages .....	240
Control Panel NV Memory .....	241
Clear Control Panel NV Memory Procedure .....	241
Control Panel IP Information .....	242
Kayenne/Karrera Menu Panel IP Information .....	242
Video Processor Frame Maintenance .....	242
Video Processor Frame NV Memory .....	242
Clear NV RAM for Control Panel and Frame .....	242
Restore System Files .....	243
Restoring Multiple Suites .....	243
IP Address Information .....	243
License Information .....	243
VP Frame Processor Board Replacement .....	243
Lifetime of the Internal Battery .....	244
Video Processor Frame Battery Replacement .....	244
IP Information .....	245
Kayenne/Karrera Menu Panel IP Information .....	245
Kayenne Control Panel System Bar Maintenance .....	245
Removing the Kayenne System Bar .....	246
Replacing the Kayenne System Bar .....	247
Diagnostics .....	248
Capture Software Diagnostic Data .....	248
Kayenne Control Panel Module Diagnostics .....	249
When to Update the HAD FPGA .....	250
Update the HAD FPGA .....	250
Update the HAD FPGA Using a Telnet Session .....	252
Creating Compact Flash Cards .....	255
Materials Required .....	255
CF Card Formatting Procedure .....	255
Updating System Software on a New Control Panel CF Card .....	257
Restore Control Panel Configuration Files .....	257
SNMP Monitoring .....	257
Grass Valley Switcher Device Monitoring by SNMP .....	258
Video Processor Frame .....	259
Control Panel .....	259
Menu Panel Processor .....	259
SNMP Installation .....	259
SNMP Licensing .....	259
Licensing Definitions .....	260
SNMP Power Up License Processing .....	260
SNMP Licensed Configuration .....	261
Switcher Device SNMP Configuration Procedure .....	261
SNMP Trap Messages .....	262
Video Processor Frame Traps .....	263
Control Panel Traps .....	264

**Appendix A Specifications .....265**

K-Frame Video Processor Specifications ..... 265  
Kayenne K-Frame Control Panel Specifications ..... 268  
Karrera K-Frame Control Panel Specifications ..... 270  
GV Korona K-Frame Panel Specifications ..... 271

**Appendix B Field Replaceable Units .....273**

Karrera K-Frame Control Panel Field Replaceable Units ..... 277

**Appendix C Regulatory Notices .....281**

Certifications and Compliances ..... 281  
    FCC Emission Control ..... 281  
    Canadian EMC Notice of Compliance ..... 281  
    EN55022 Class A Warning ..... 281  
    Canadian Certified AC Adapter ..... 281  
    FCC Emission Limits ..... 282  
    Certification ..... 282  
    DEKRA Certificate ..... 283



# 1 Introduction

## Overview

The Grass Valley K-Frame family of multi-format digital production switchers provides powerful, ground-breaking features designed to meet the widest range of requirements for live studio, mobile, and post-production applications.

The K-Frame Video Processor is the heart of the system, providing extensive video switching and signal processing capabilities. This functionality is controlled using a:

- Kayenne control surface,
- Karrera control surface,
- GV Korona control surface,
- the Soft Panel (KSP option), and/or
- the Menu application running on a PC.

In addition, a K-Frame system supports direct control of external devices (DDRs, Servers) and bi-directional control to and from routing and automation systems.

## Features

### General

- Fully digital 10-bit 4:2:2 video switcher including Future-Ready 4K and 1080p (level A or B) support.
- Optional smart I/O modules provide up/down/cross-conversion when licensed with SetDef and MatchDef.
- The K-FRM-IO-10GE IP I/O board for the K-Frame video processing engine offers Video-Over-IP connectivity for all K-Frame Video Production Switchers, using either uncompressed SMPTE 2022-6 or 4K 1-wire compressed IP.
- Integrated Macro Builder/Editor allows users to edit macros online or offline on a PC running the menu application.
- Optional DoubleTake™ (split M/E mode) effectively increases the number of M/Es and adds flexibility to Suites operation while FlexiKey™ programmable clean feed mode supports separately programmable configurations of keyers from four M/E outputs.
- Aux bus transitions for dissolves and wipes on aux bus outputs.
- Interfaces with Grass Valley routers and Kaleido Multiviewers and their control systems.
- Optional Integrated Image Store capable of delivering up to 32 GB storage of Stills (3,000 images) or "Movies" (a total of 50 seconds) of 1080p video.
- LDK Series and LDX Series camera control with Ethernet tally via Connect Gateway.

- Optional integrated external ClipStore provides multiple channels of video/key pairs for up to 10+ hours of nonvolatile video/key/audio clip content.
- 999 macros with many new ways to recall macros from the Control Panel.
- 1,000 E-MEM registers with Define E-MEM for fine control in creation and editing of effects.
- Optional M/E Previewer provides a method to check and monitor any input to an M/E.
- VDCP Ethernet connection for stadium applications.
- Ethernet tally connection for integration with external tally systems.
- Optional RGB color correction on M/E buses and aux bus outputs.
- Source Rules:
  - Links keyers to sources.
  - Settings for On/Off/Left Alone on every M/E.
  - Full look-ahead preview of rules.
- Hot-swappable, front/rear removable modules and power supplies.
- Optional multiple Multiviewer capability with 5 pre-configured layouts (maximum 14 panes per layout) with On-Air and Preview tally.

## **K-Frame Standard Frame**

- Up to 192 inputs and 96 outputs.
- Up to 9 M/Es, accessible across two suites—by using DoubleTake this may be increased to 18 virtual M/Es.
- Every M/E has six keyers with standard keying modes including Chroma Key, two frame stores per keyer—every keyer except for Controller M/E can use the pool of floating 3D iDPMs.
- 2D-DPMs (resizers) on every keyer, with 6 Video/Key pairs per M/E so iDPMs can be utilized for more complex effects.
- The Controller M/E has a complement of 6 full keyers with Chroma Key and 2D-DPMs.
- Up to 16 iDPMs (Integrated Digital Picture Manipulators), assigned as either floating iDPMs or within an eDPM at user's discretion.

## **K-Frame Compact Frame**

- Up to 80 inputs and 48 outputs.
- Up to 5 M/Es, accessible across two suites, increased to 10 virtual M/Es by using DoubleTake.
- Every M/E has six keyers with standard keying modes including Chroma Key, two frame stores per keyer—every keyer except for Controller M/E can use the pool of floating 3D iDPMs.
- 2D-DPMs (resizers) on every keyer, with 6 Video/Key pairs per M/E.
- The Controller M/E has a complement of 6 full keyers with Chroma Key and 2D-DPMs.
- Up to 8 iDPMs (Integrated Digital Picture Manipulators), assigned as either floating iDPMs or within an eDPM at user's discretion.

## K-Frame Compact S-series Frame (Differences)

- Up to 6 M/Es, accessible across two suites, increased to 12 virtual M/Es by using DoubleTake.
- Every M/E has four keyers with standard keying modes including Chroma Key—every keyer can use the pool of floating 3D iDPMs.
- 2D-DPMs (resizers) on every keyer, with 4 Video/Key pairs per M/E.
- Two Built-in multiviewers with five pre-configured layouts (maximum 14 panes per layout) with On-Air and Preview tally.

## K-Frame Video Processor

The GV Korona system consists of a GV Korona Control Panel and a S-series 6RU Compact K-Frame, however the GV Korona control surface can be used with any K-Frame Standard 13RU or Compact 6RU Video Production Frame.

The K-Frame Video Processor is available in two sizes, the 13RU Standard and the 6RU Compact and S-series. The number of licensed boards present in the frame determines the number of MEs available, as well as the number of video inputs, outputs, GPIOs and Relay Tallies.

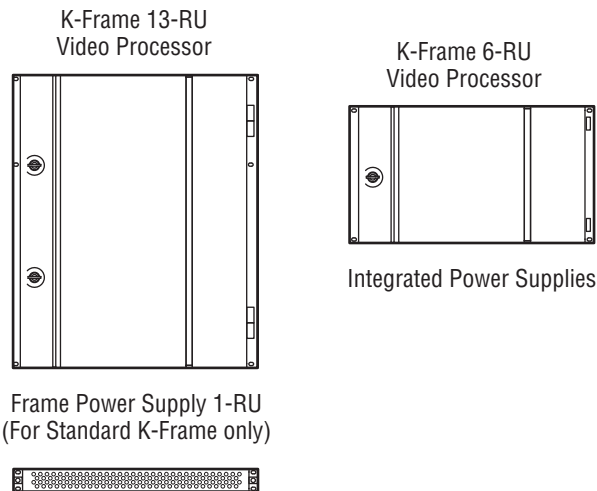

*K-Frame Video Processor Frames*

8875\_0111

## K-Frame Control Surfaces

### Kayenne Control Surface

A Kayenne control surface typically consists of a Control Panel, a Menu Panel with an included articulated support arm, a Panel Control Unit (PCU) frame, and optional Satellite Panels. This control surface has an innovative modular design.

4-ME 35 Control Panel

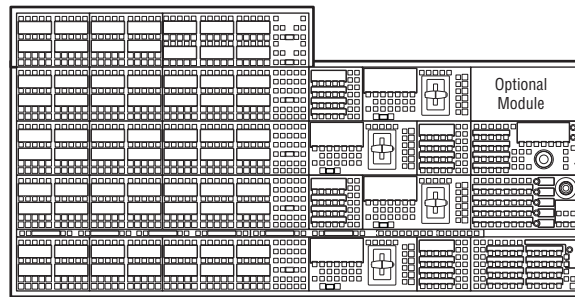

Menu Panel

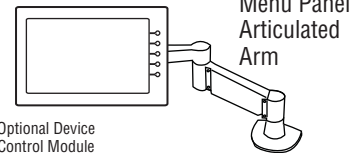

Optional Device Control Module

Panel Control Unit (PCU)



8623266\_01

*Kayenne 4-ME 35 Control Surface*

3-ME 35 Control Panel

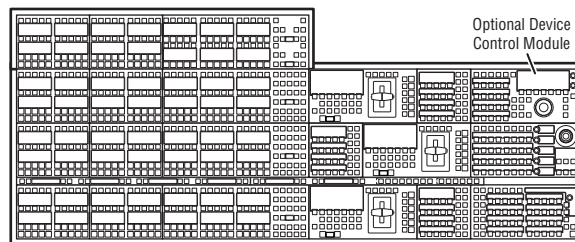

Menu Panel

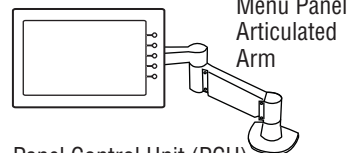

Panel Control Unit (PCU)

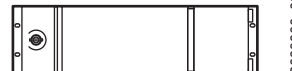

8623266\_02

*Kayenne 3-ME 35 Control Surface*

2-ME 25 Control Panel

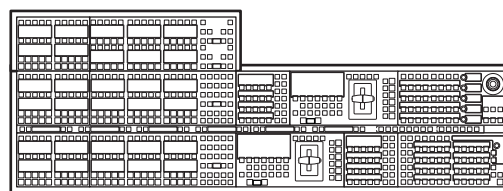

Menu Panel

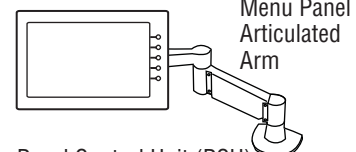

Panel Control Unit (PCU)



8623266\_03

*Kayenne 2-ME 25 Control Surface*



1-ME 15 Control Panel

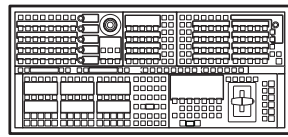

Menu Panel

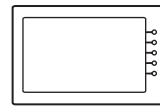

Menu Panel  
Articulated  
Arm

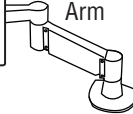

Panel Control Unit (PCU)



8623266\_04

*Kayenne 1-ME 15 Control Surface*

The modular design and use of a separate PCU supports the hot-replacement of individual Control Panel components, if necessary, while the rest of the system remains operational.

**CAUTION:** Do not connect or disconnect the PCU to Control Panel cables while the system is powered on.

### Flat or Curved Control Panel Orientation

The main Kayenne Control Panel supports different physical orientations. Besides a conventional flat surface, a special support design permits a curved working surface, where the MEs progressively tilt for improved ergonomics.

Curved Control Panel Assembly

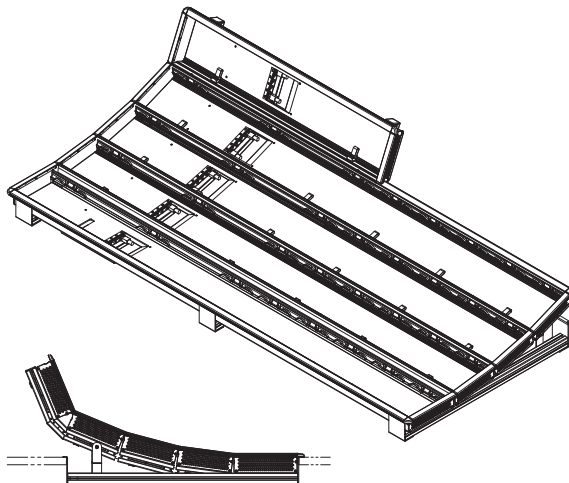

Flat Control Panel Assembly

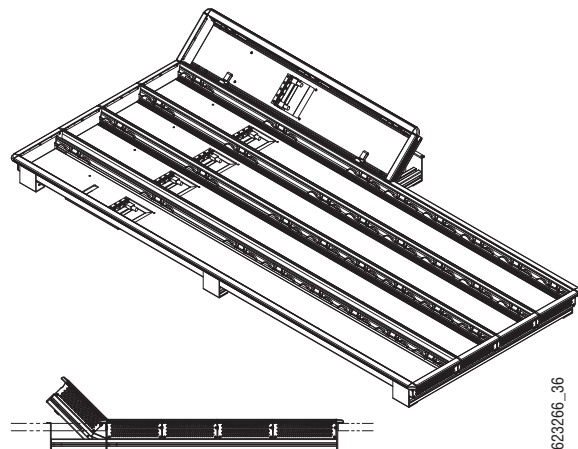

8623266\_36

*Curved and Flat Control Surface Installations*

### Control Panel Stripes

The main Kayenne Control Panel is organized into from one to five Stripes. Each Stripe consists of a tray and its complement of drop-in modules. An ME Stripe has a module for Source Selection, Transition, and individual E-MEM control. Additional Master E-MEM, Machine Control, Multi-Function, and Local Aux modules are populated to complete the control surface functionality.

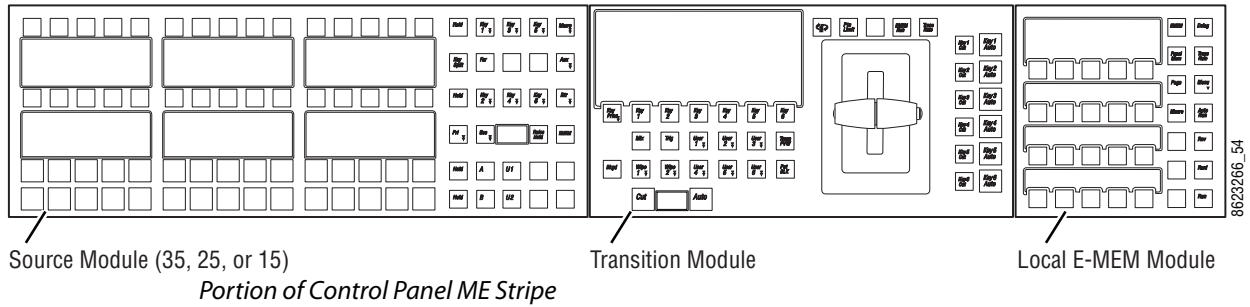

### Touch Screen Menu Panel

Each Kayenne control surface includes a Menu Panel that features a wide format 15 in. touch screen display. An articulated arm is also included, offering a wide variety of installation options. The Menu Panel has a standard VESA-75 hole pattern and M4 threads, compatible with this and many other mounting devices.

The Menu Panel has four USB ports, two on the right side edge of the panel and two on the back for keyboard and mouse (wired or wireless are supported).

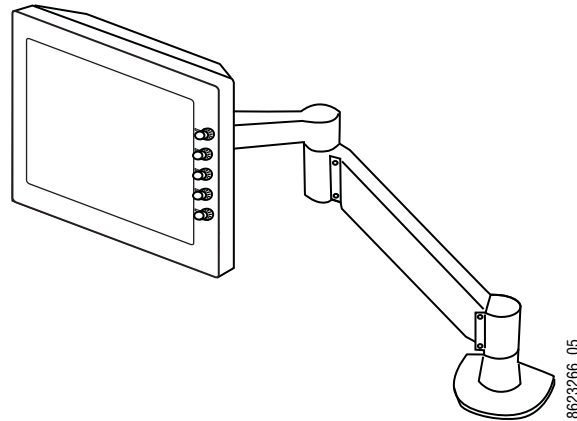

*Menu Panel with Articulated Arm*

### Menu Application

The Menu application software provided with every K-Frame system can be run on a standard PC. This software accesses all the system's functionality, permitting mouse and keyboard control from a laptop, or remote control from any location on the network.

### Basic Single Suite Kayenne Panel System

A basic K-Frame system consists of a Control Panel, a Menu application running on a touch screen Menu Panel, and a Video Processor Frame. The Control Panel and Menu application make up a control surface associated with that frame. The Kayenne Control Panel and Menu Panel have associated active electronics housed in the Panel Control Unit (PCU).

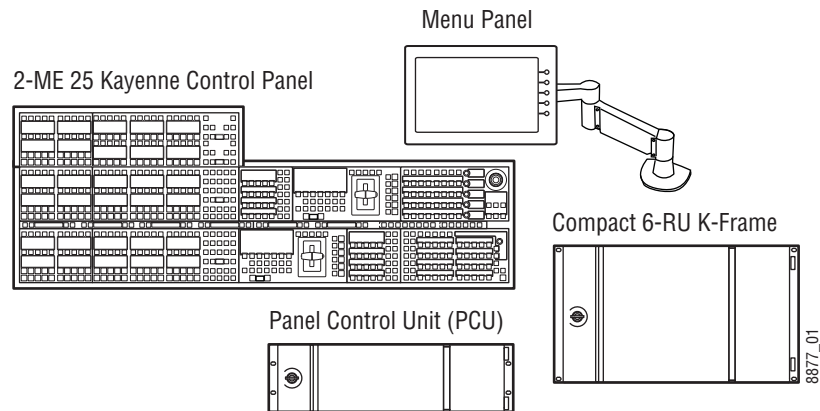

*Kayenne Single Suite Compact Frame Example*

### **Multiple Suite Kayenne Panel System**

A K-Frame system can be subdivided into two suites, if desired, each of which can have two control surfaces (Surface A and Surface B). Each surface has its own set of Panel Preferences for configuration of the control panel behavior and independent macro systems to allow for independent building and running of macros by each operator at the control surface. Hardware resources in the Video Processor Frame can be assigned to an individual suite during configuration, essentially creating two separate switchers sharing one frame.

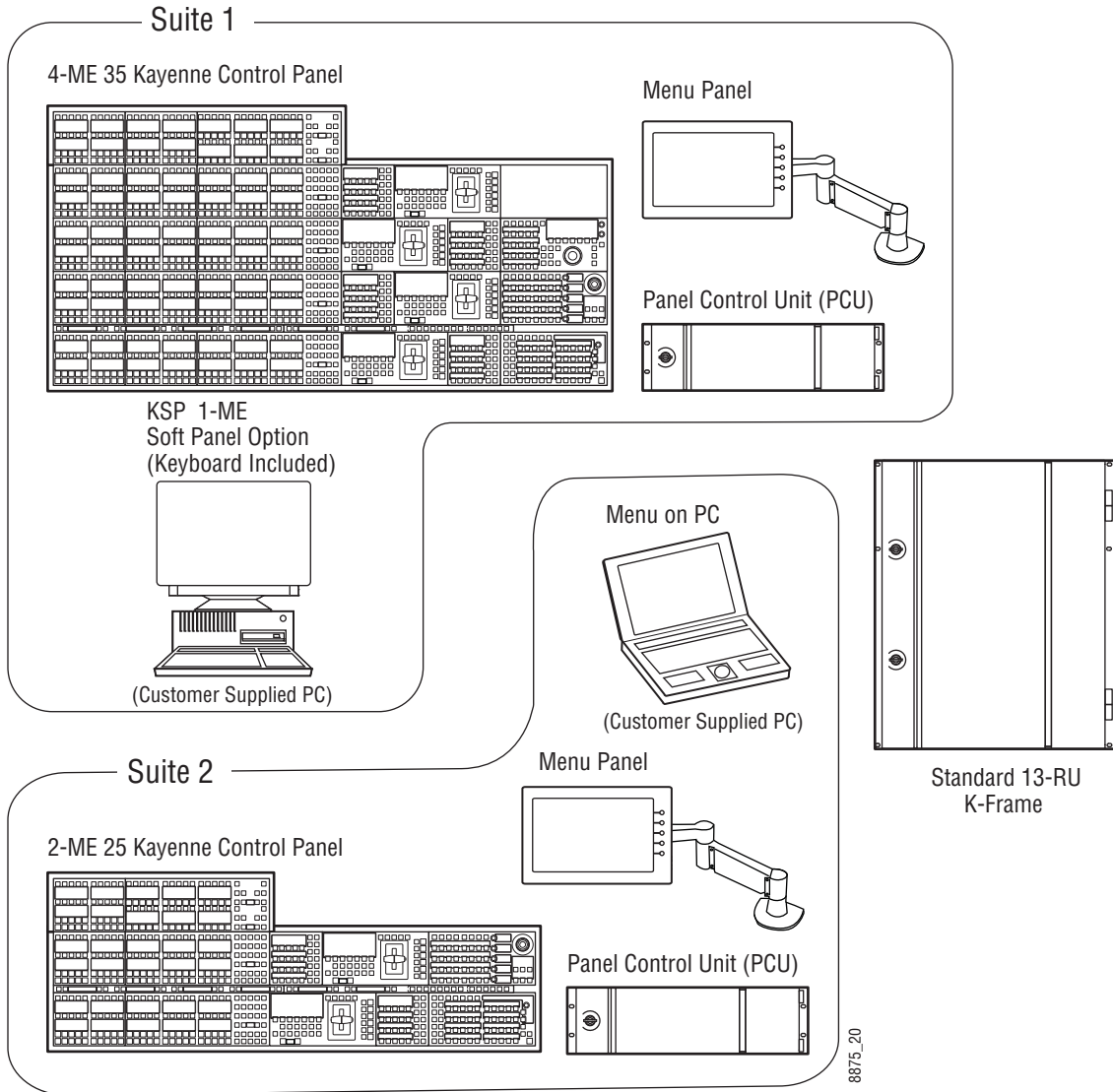

## Karrera Control Surface

A Karrera control surface typically consists of a Control Panel and a Menu application. Representative Karrera control surfaces are shown in the following illustrations.

Karrera 3-ME 35 Control Panel

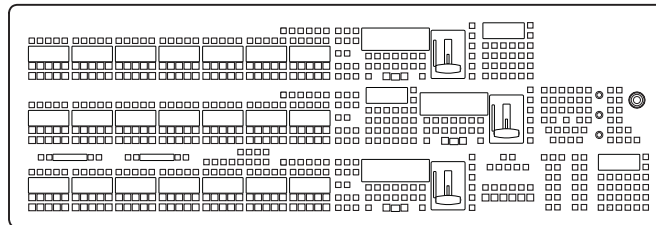

*Karrera 3-ME 35 Control Surface*

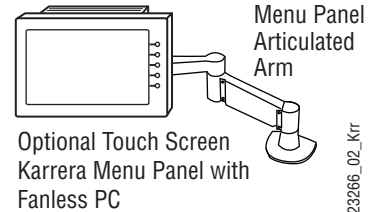

8623266\_02\_Krr

Karrera 2-ME 25 Control Panel

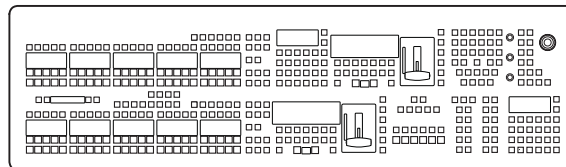

*Karrera 2-ME 25 Control Surface*

Karrera Menu on PC



(Customer Supplied PC)

8623266\_03\_Krr

## Touch Screen Menu Panel Option

A hardware Karrera Menu Panel is available as an option, which features a wide format 15 in. touch screen display. An articulated arm is also included, offering a wide variety of installation options.

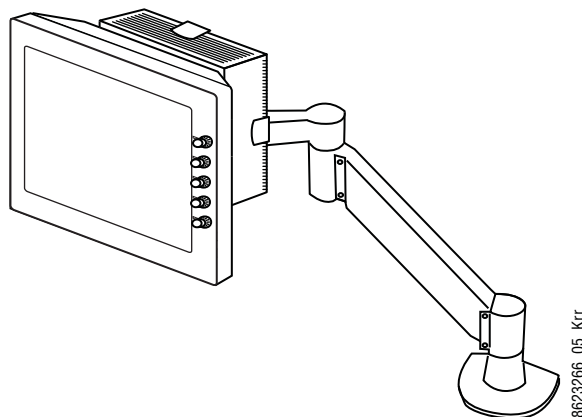

*Menu Panel with Articulated Arm*

The Menu Panel has a standard VESA-75 hole pattern and M4 threads, compatible with this and many other mounting devices. The Menu Panel also has four USB ports, two on the

right side edge of the panel and two on the back for keyboard and mouse (wired or wireless are supported).

A fanless PC, running Windows OS, is available which mounts behind the Menu Panel.

## Karrera K-Frame System Examples

### Basic Single Suite Karrera Panel System

A basic K-Frame system consists of a Control Panel, a Menu application running on a PC, and a Video Processor Frame. The Control Panel and Menu application make up a control surface associated with that frame.

Karrera 2-ME 25 Control Panel

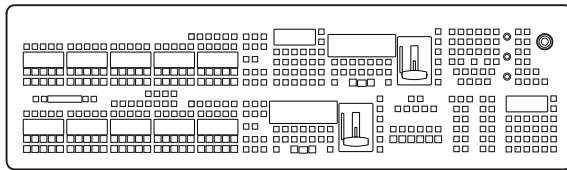

Karrera Menu on PC



(Customer Supplied PC)

Compact 6-RU K-Frame

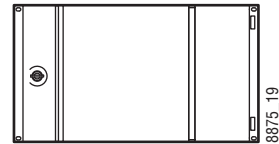

88715\_19

*Karrera Single Suite Compact Frame Example*

### Multiple Suites and Control Surfaces

A K-Frame system can be subdivided into two suites, if desired, each of which can have two control surfaces. Hardware resources in the Video Processor Frame can be assigned to an individual suite during configuration, essentially creating two separate switchers sharing one K-Frame.

Suite 1

Karrera 3-ME 35 Control Panel

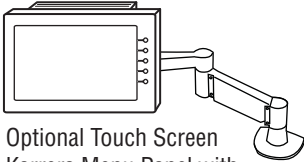
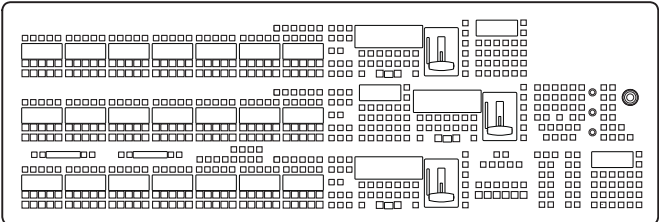

Optional Touch Screen  
Karrera Menu Panel with  
Fanless PC and  
Articulated Arm

KSP 1-ME  
Soft Panel Option  
(Keyboard Included)

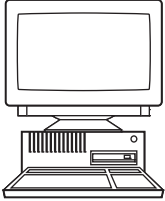

(Customer Supplied PC)

Standard 13-RU  
K-Frame

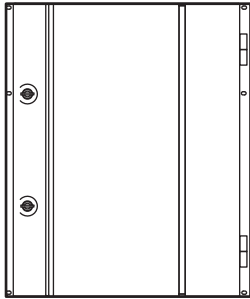

8878\_01

Suite 2

Karrera 2-ME 25 Control Panel

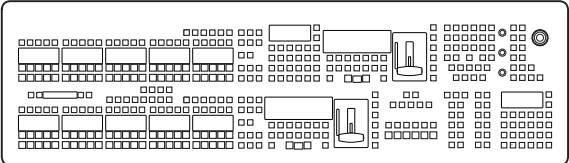

Karrera Menu on PC



(Customer Supplied PC)

*Karrera Multi-Suite Standard Frame Example*

## GV Korona Control Surfaces

A GV Korona control surface consists of:

- A Control Panel with stripes of buttons,
- System Control area with a Device Control area,
- Switched preview,
- Alternate bus and Aux bus delegation,
- Macro controls,
- Controls for background and keyer source selection,
- Multi-Function and E-MEM area,
- Horizontal keyer cut/mix,
- Multi-function keypad and display, and
- Includes a built-in multi-touch display and menu system.



*GV Korona Control Surfaces*

### Basic Single Suite GV Korona Panel System Example

A Basic K-Frame GV Korona system consists of a Control Panel with a fully integrated multi-touch menu system and an S-series 6RU Frame.

GV Korona 2-ME 20 Control Panel

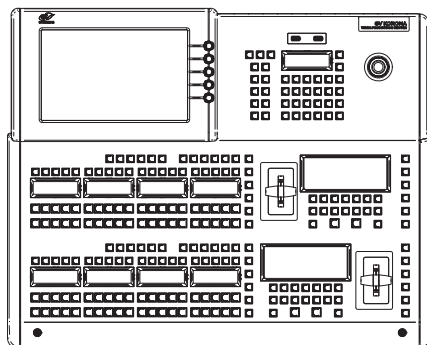

K-Frame S-series 6-RU

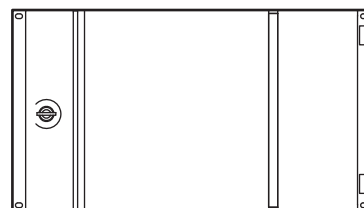

6600\_04



*GV Korona Single Suite S-Series Frame Example*

**Multiple Suites and Control Surfaces Example**

Any K-Frame Keyenne, Karrera, or Korona Control Panel can be configured with any K-Frame Video Processor. The K-Frame system can be subdivided into two suites and each suite can have up to two control surfaces. Hardware resources in the Video Processor Frame can be assigned to an individual suite during configuration, essentially creating two separate switchers sharing one Frame. See the K-Frame Installation & Service Manual for suite configuration information.

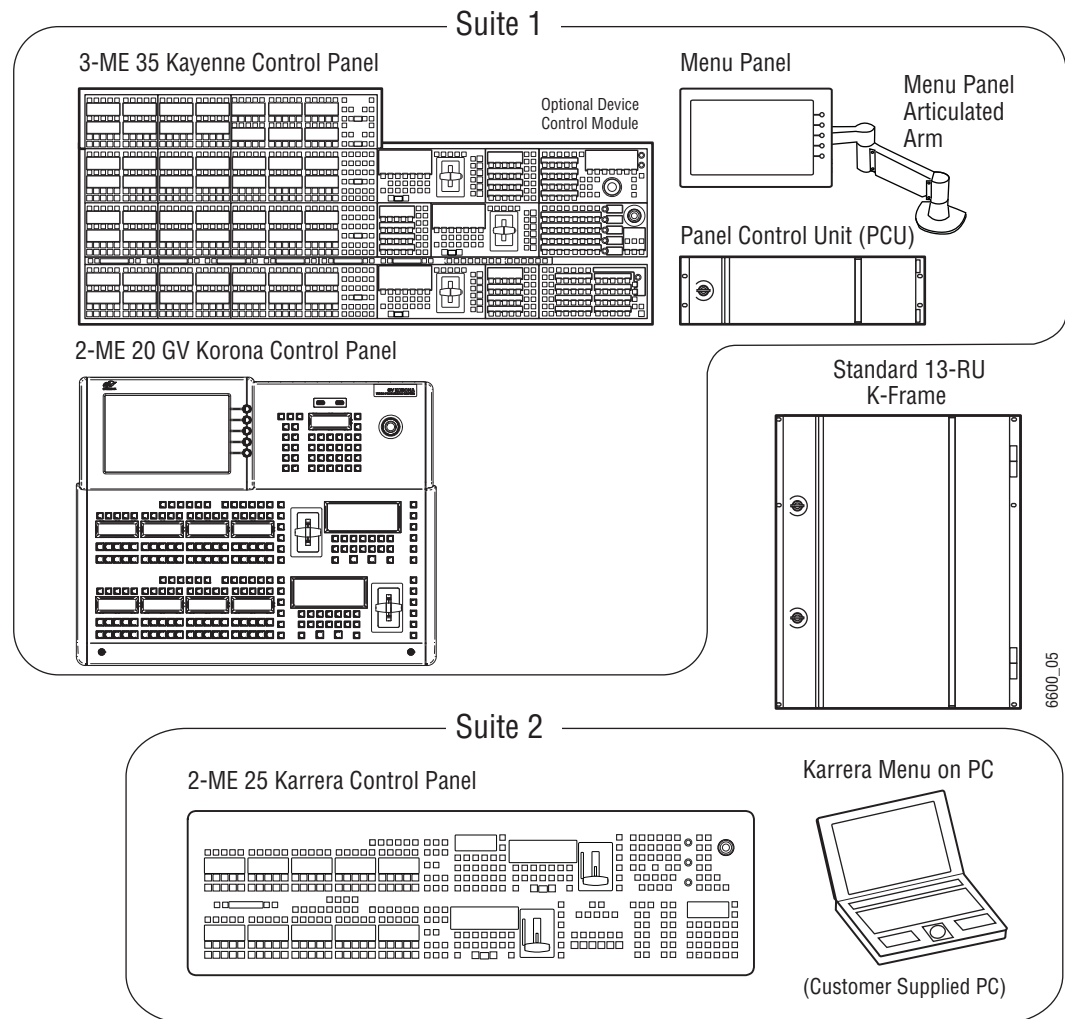

*K-Frame Multi-Suite Frame Example*

## Soft Panel (KSP) Option



### *Soft Panel Application*

The KSP is an optional 1-ME Soft Panel GUI which provides direct control of switching crosspoints, recalling effects and macros together with an integrated version of the Menu application. A customized PC keyboard is included with the option for users who like quick cut and mix action from a hard-button interface. The KSP can be used as an adjunct to a main panel, providing a second seat (second control surface) in a Suite, or as the only control surface for a second Suite.

The KSP GUI application is designed to run on a PC platform. The screen must be 1920x1080 resolution or better (which is common in professional video environments). A touchscreen is not required, but can be very useful.

The KSP software is included with the switcher application software. Purchasing the option provides a software license that enables the interface for the selected switcher, and includes a customized PC keyboard. The license activates an unlimited number of KSP applications associated with the licensed video processor frame. Additional customized PC keyboards are also available for purchase.

## Menu Application

The Menu application software provided with every K-Frame system can be run on a standard PC. This software accesses all the system's functionality, permitting mouse and keyboard control from a laptop, or remote control from any location on the network.

## Supported Control Protocols

- Ethernet
- PBus II
- GPI Inputs and Outputs
- Serial BVW-75 for VTR control
- Odetics protocol for VTR control
- AMP (advanced media protocol) for Profile PVS, Profile XP Media Platform, K2, M-Series, Turbo iDDR, and T2 iDDR systems over Ethernet
- Grass Valley Native Protocol for routers/routing control systems (Trinix/Trinix NXT, Venus™, Triton™, and third-party routers; Jupiter NV9000 and NV920, and Encore router control systems)
- Tally (contact closure)
- K-Frame Ethernet Tally protocol
- Ethernet CPL to control Grass Valley external remote AUX Panels
- Grass Valley Editor protocol
- SNMP system monitoring
- Serial and Ethernet VDCP
- LDK Series & LDX Series™ camera control with Ethernet tally via Connect Gateway



# Control Surface Installation



## K-Frame Control Surfaces

- Kayenne and Karrera Control Panels support an optional external Menu Panel, included in this section.
- GV Korona Control Panels have a built-in multi-touch menu.

## Kayenne K-Frame Control Surfaces

A typical Kayenne control surface has a modular Control Panel, a Menu Panel, and is driven by a Panel Control Unit (PCU) frame. Additional Menu Panels and Satellite Panels are available as options.

A Control Panel consists of system operation modules, which mount into trays, which are in turn held in place by a Control Panel support structure. One Control Panel tray filled with modules is called a Stripe. Various numbers and types of modules and trays can be combined to create a wide variety of control surface functionality.

The Control Panel and Menu Panel's processing electronics are located in the PCU. The Stripes and Menu Panels are connected to the PCU via multi-pin cables that carry power and communication signals.

Kayenne Control Panels ship to the customer as boxed Stripes, which are assembled with the support structure on site. You will need to know what Control Panel configuration(s) you intend to use at your facility in order to plan your installation effectively.

The Kayenne Control Panel support kit uses 30mm series components sourced from Bosch Rexroth.

## Control Panel and Support Structure Assembly

If you purchased commissioning with your K-Frame system, assembly of the Control Panel support is included as part of the commissioning.

If you did not purchase commissioning, but would like to reconsider the option, contact Grass Valley Customer Support.

## Control Panel Variations

Seven basic Control Panel assemblies are considered standard: 4-ME 35, 4-ME 25, 3-ME 35, 3-ME 25, 2-ME 35, 2-ME 25, and 1-ME 15. Each assembly name identifies the number of MEs present and the number of source selector buttons in each ME.

Two Control Panel Assembly orientations are possible, flat and curved. The curved panel provides improved operator ergonomics. This orientation raises the Control Panel height,

so visibility of a monitor wall should be considered prior to installation. An assembled Control Panel can be operated from a tabletop, or it can be installed into a cutout.

The Local Aux Stripe can be connected to the Control Panel support structure at a 45 degree angle, or it can be mounted separately in its own backsplash cutout.

The following diagrams show some standard Control Panel assemblies. It is also possible to create different Control Panel assemblies (for example, a 2-ME 35), since the parts are interchangeable. Specific information for non-standard configurations is not included in this document.

## Control Panel Cooling

The Kayenne Control Panel is externally powered and does not have internal cooling fans. Electronics in the panel are convection cooled and require free air movement. Do not install the panel into a sealed space.

**CAUTION:** If the panel is mounted in a counter-top, do not enclose the lower portion of the cutout. Leave the bottom open to allow passive air movement.

## Truck and High Vibration Environment Considerations

The Kayenne Control Panel has several bolt and screw tightened components. In high vibration environments these attachments could loosen over time. Loctite Blue 242 or equivalent thread locking compound is recommended for these environments. This compound is designed to lock threaded components together during assembly, but permits them to be loosened if necessary later using hand tools.

During Control Panel assembly, apply a drop of the locking compound to the ends of the threads of the support beam bolts, to the screws connecting the cutout lip brackets to the support beams, and to the bolts attaching the trays to the support beams. Make sure the locking compound is present where the thread interfaces to each bolt or beam.

**4-ME 35 Control Panel, Curved Assembly**

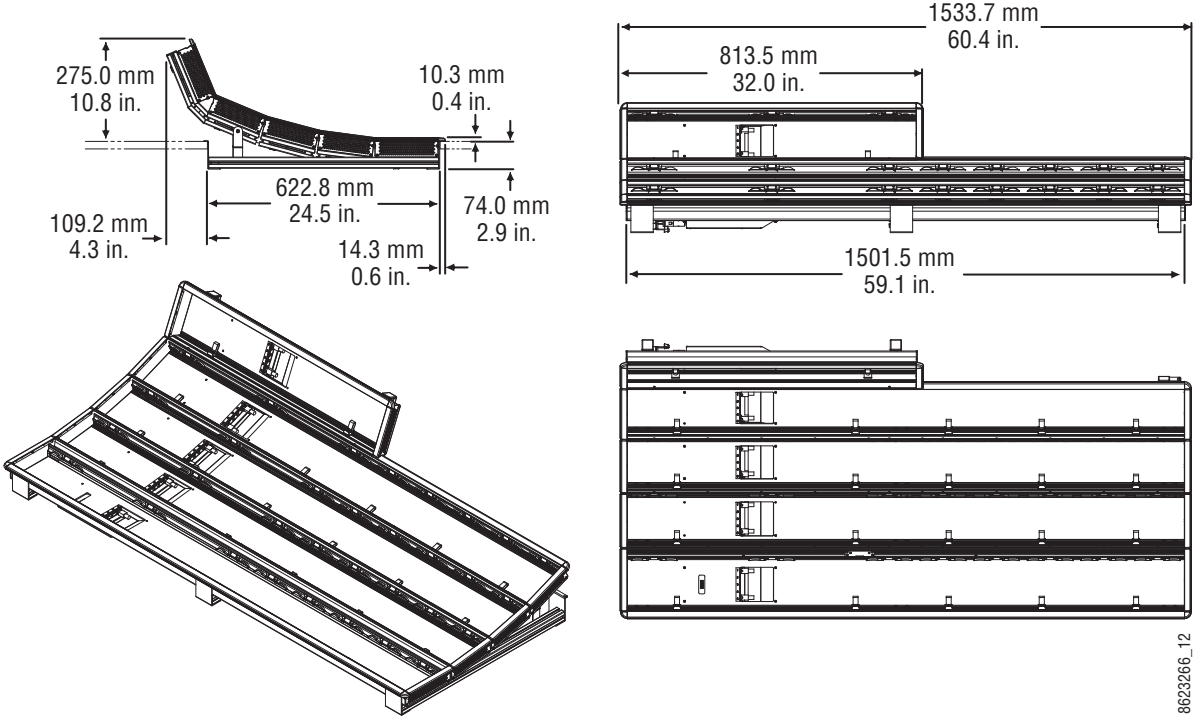

4-ME 35 Control Panel Dimensions, Curved Installation

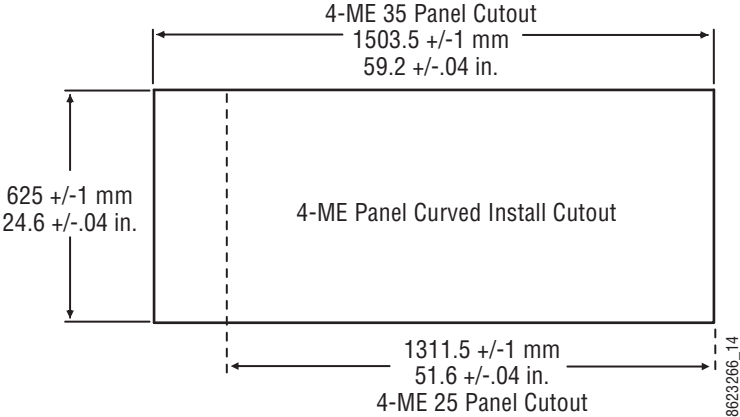

4-ME Control Panel Cutout Dimensions, Curved Installation

## 4-ME 35 Control Panel, Flat Assembly

Note Read through the entire procedure before you begin actual assembly.

Figure 1. 4-ME 35 Control Panel Dimensions, Flat Installation

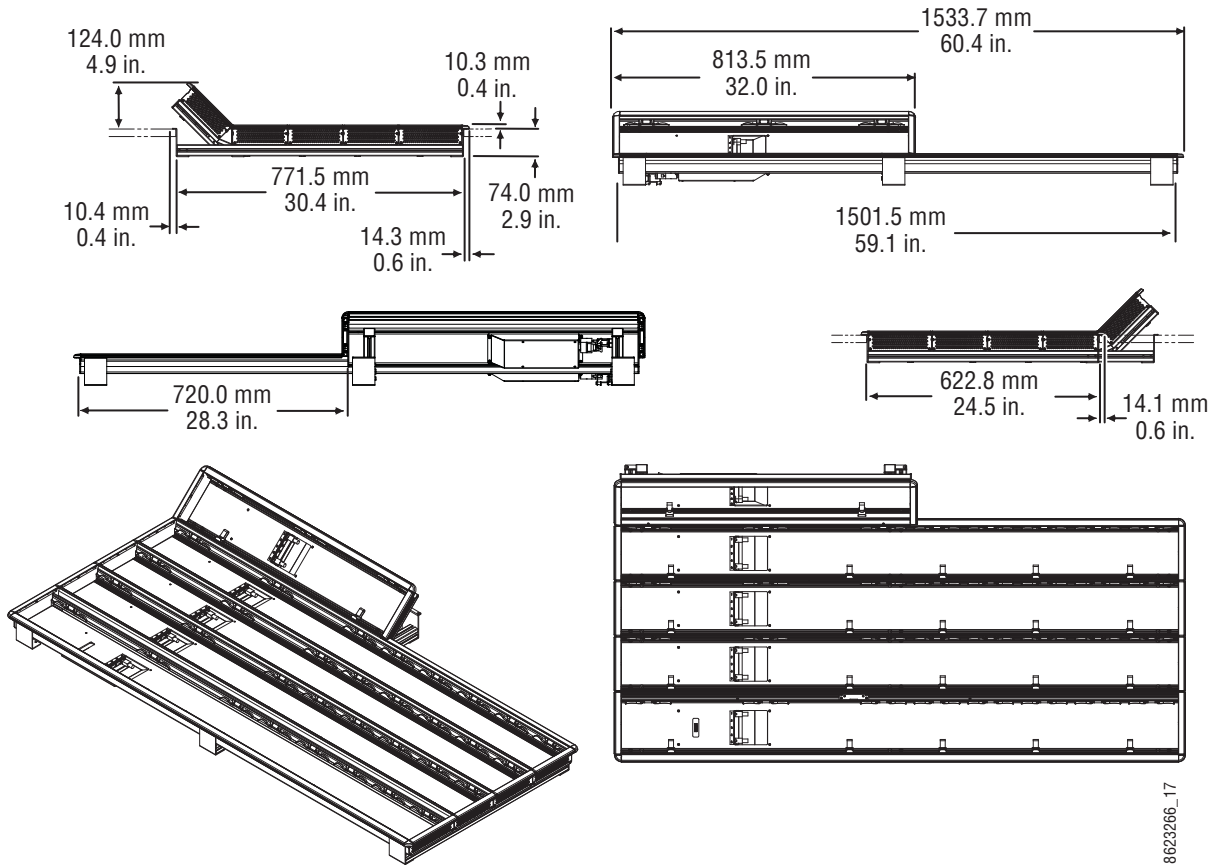
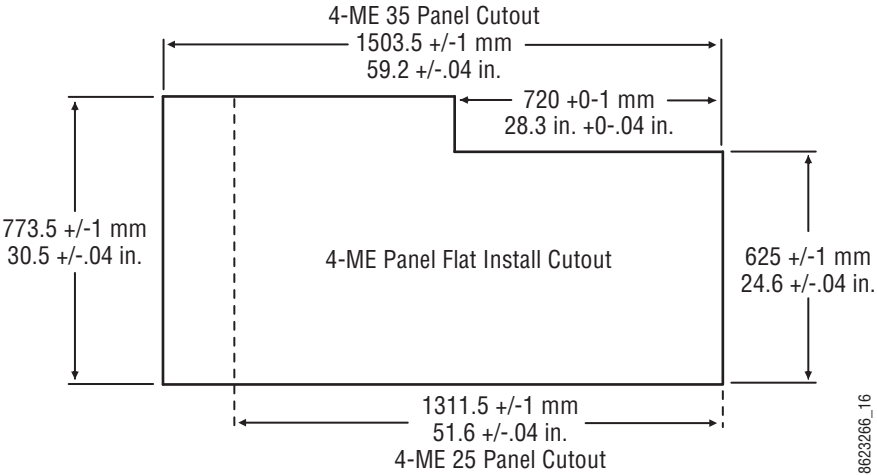

Figure 2.



Figure 3. 4-ME Control Panel Cutout Dimensions, Flat Installation







## 4-ME 25 Control Panel

Control panels with 25 source selection buttons are narrower in width, but otherwise have the same dimensions as 35 source button models.

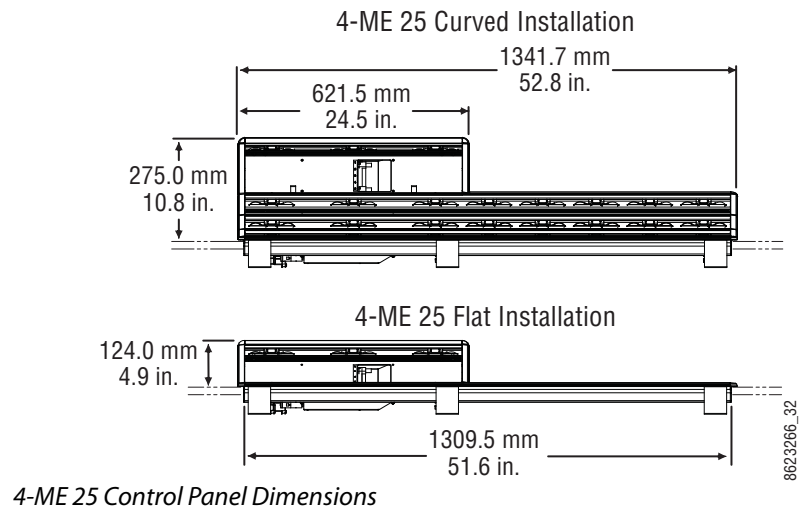

### 3-ME 35 Control Panel, Curved Assembly

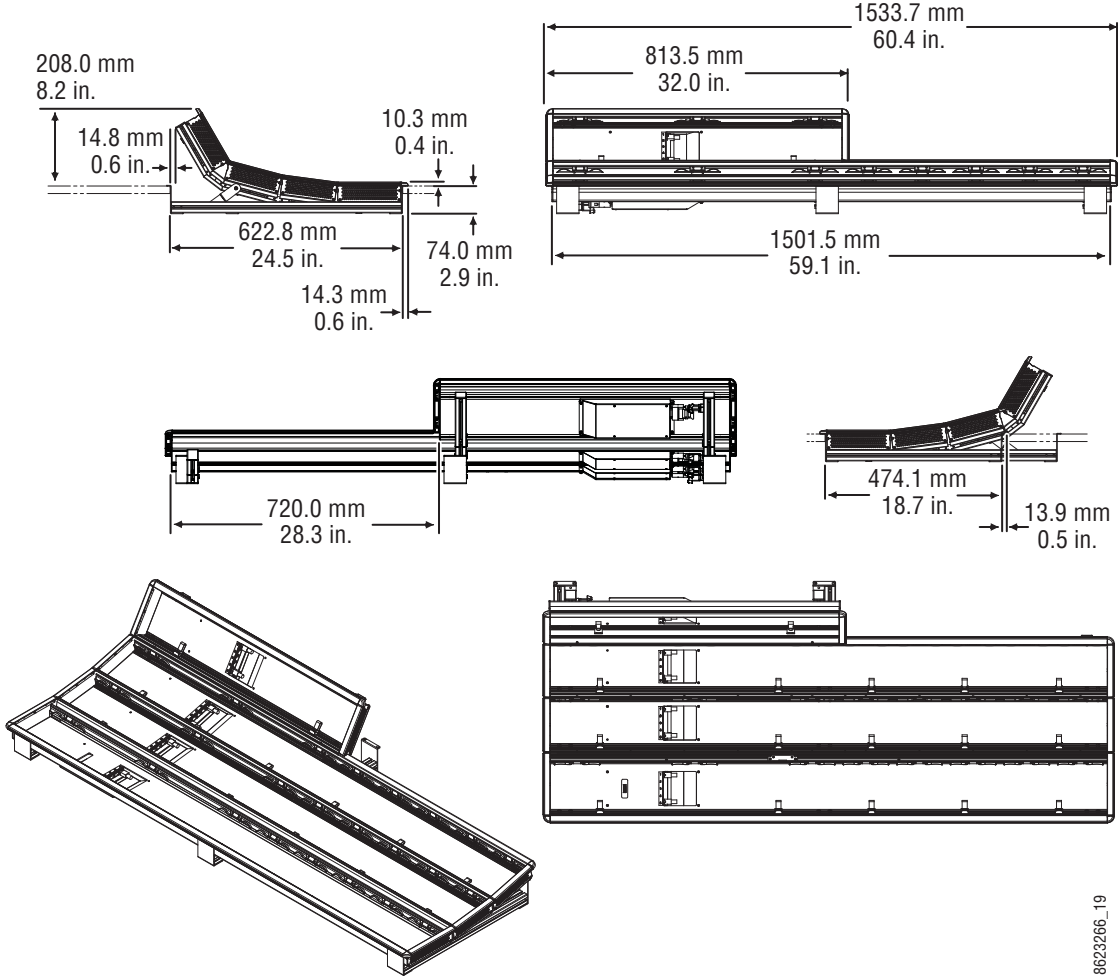

3-ME 35 Control Panel Dimensions, Curved Installation

8623266\_19

Control Surface Installation  
 3-ME 35 Control Panel, Curved Assembly

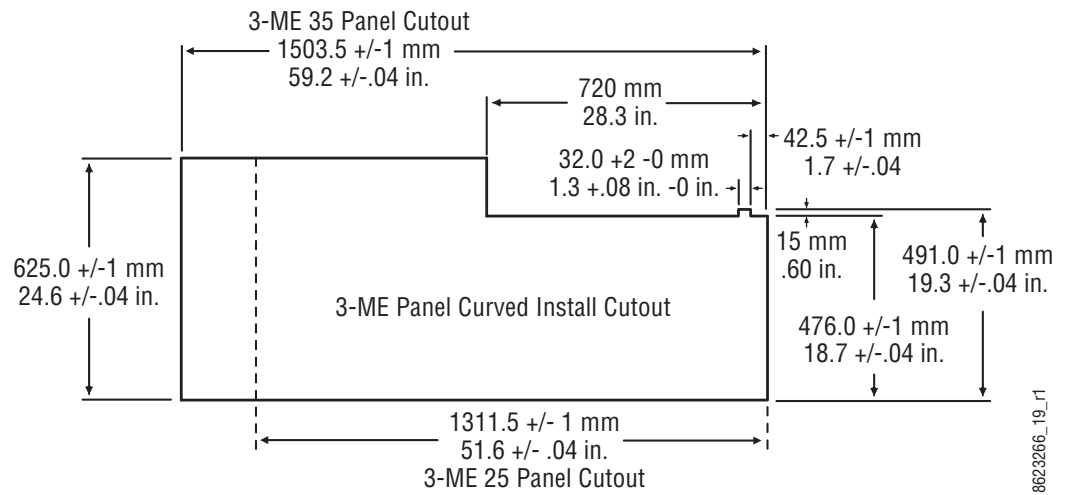

*3-ME Control Panel Cutout Dimensions, Curved Installation*



### 3-ME 35 Control Panel, Flat Assembly

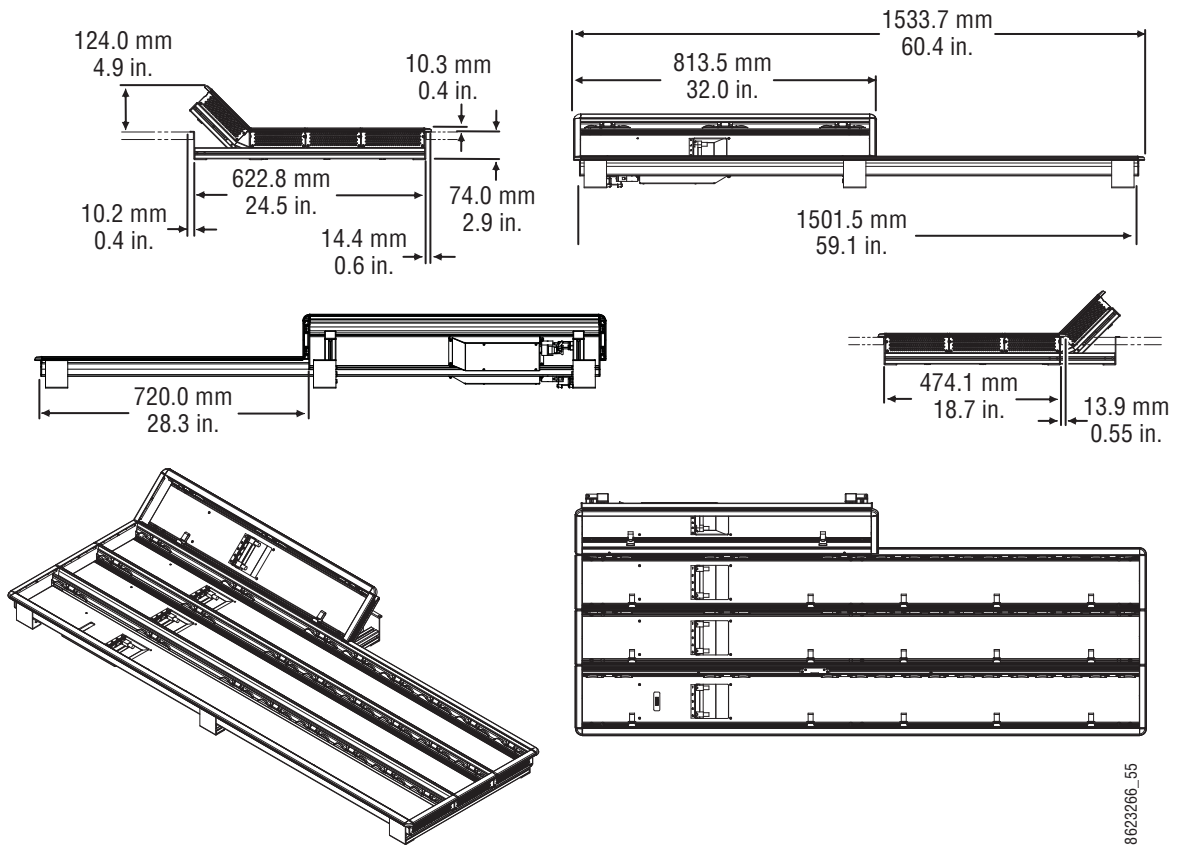

3-ME 35 Control Panel Dimensions, Flat Installation

8623266\_55

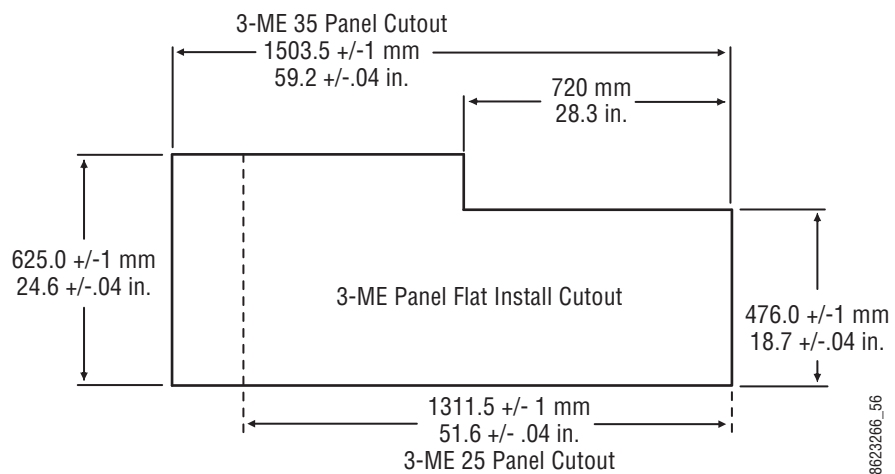

3-ME Control Panel Cutout Dimensions, Flat Installation

8623266\_56



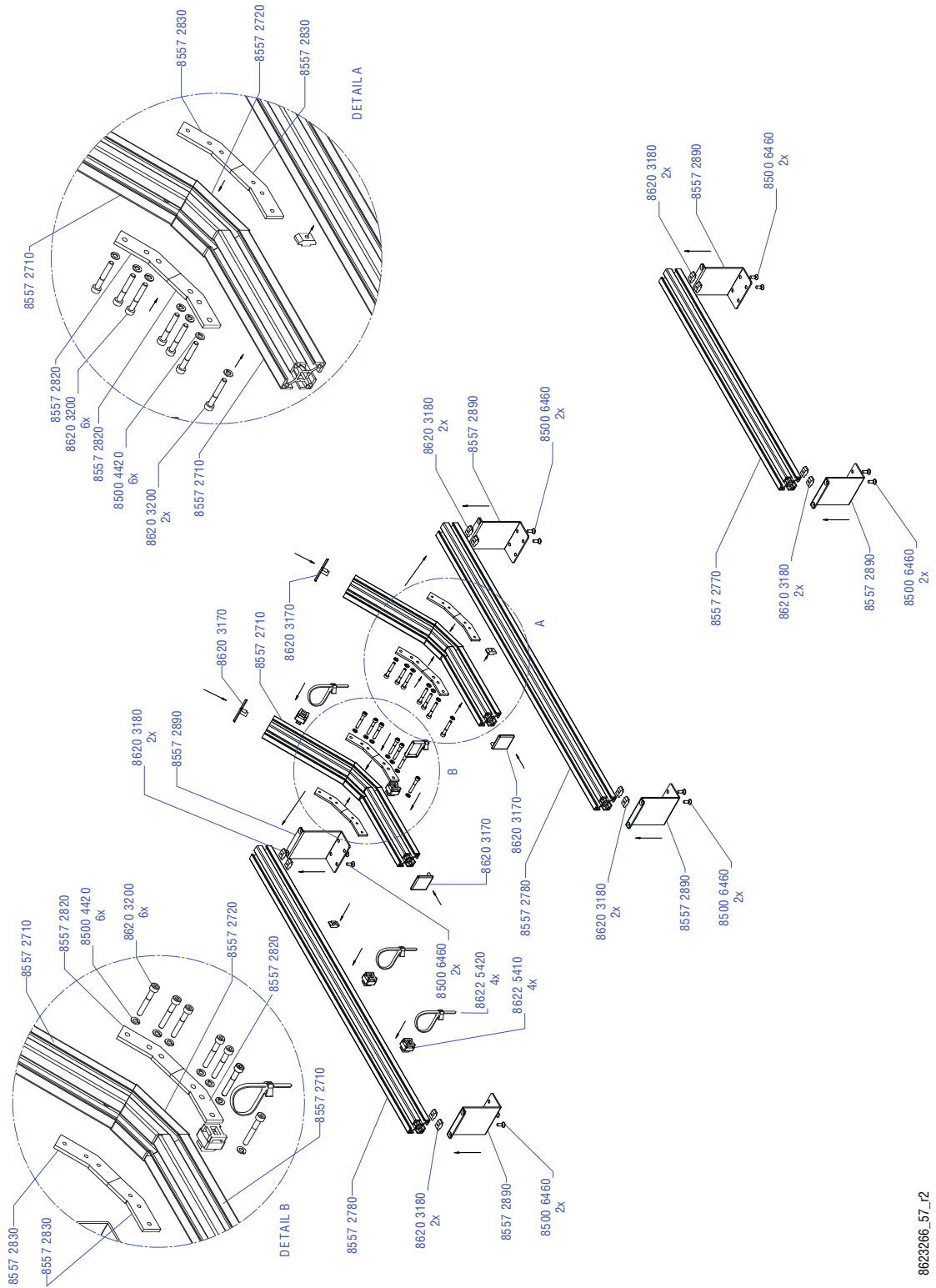

3-ME Support Structure, Flat Installation

8623266\_57\_r2

### 3-ME 25 Control Panel

Control panels with 25 source selection buttons are narrower in width, but otherwise have the same dimensions as 35 source button models.

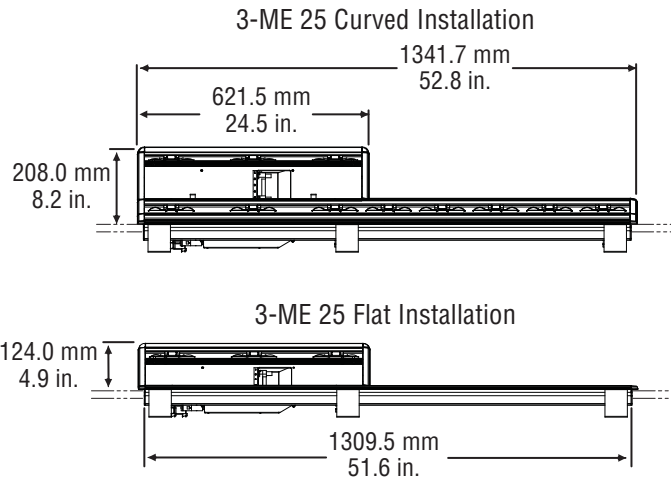

4-ME 25 Control Panel Dimensions

### 2-ME 35 Control Panel, Curved Assembly

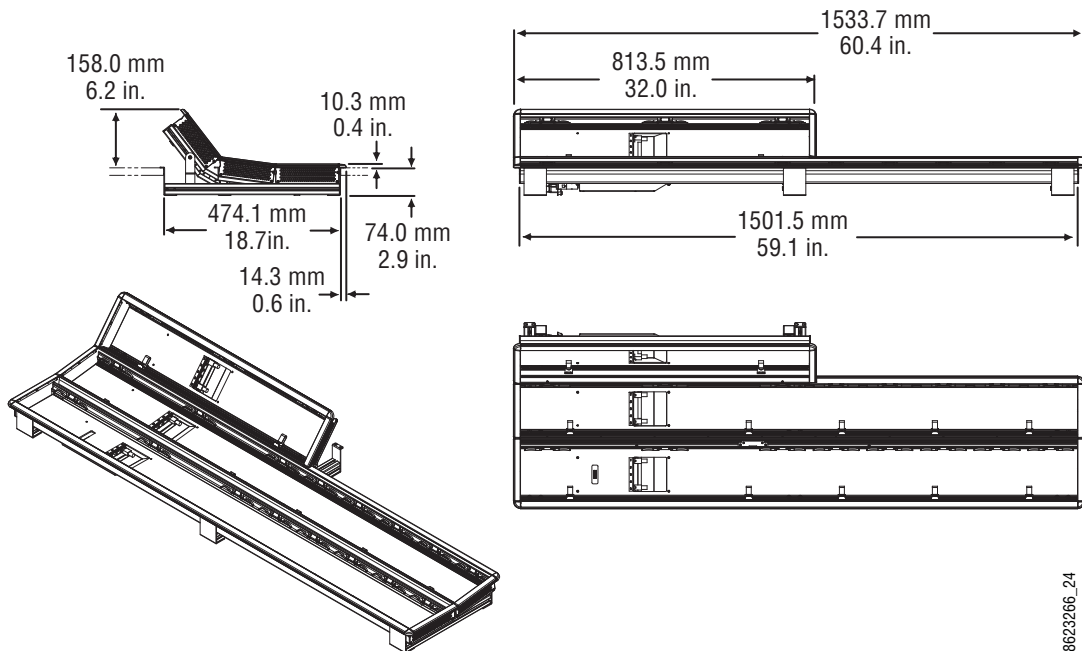

2-ME 35 Control Panel Dimensions, Curved Installation

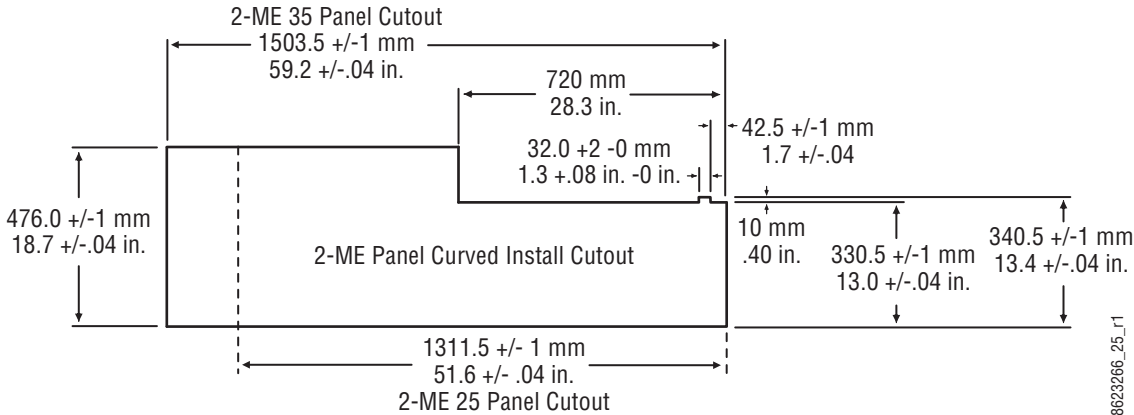

*2-ME Control Panel Cutout Dimensions, Curved Installation*



## 2-ME 35 Control Panel, Flat Assembly with Local Aux

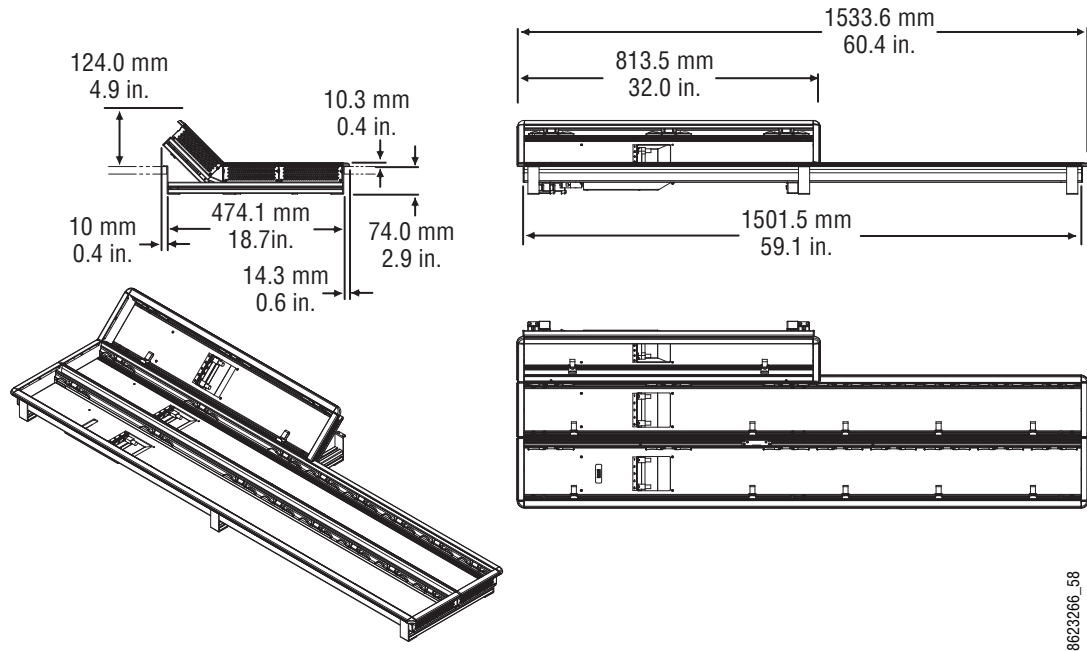

2-ME 35 Control Panel Dimensions, Flat Installation

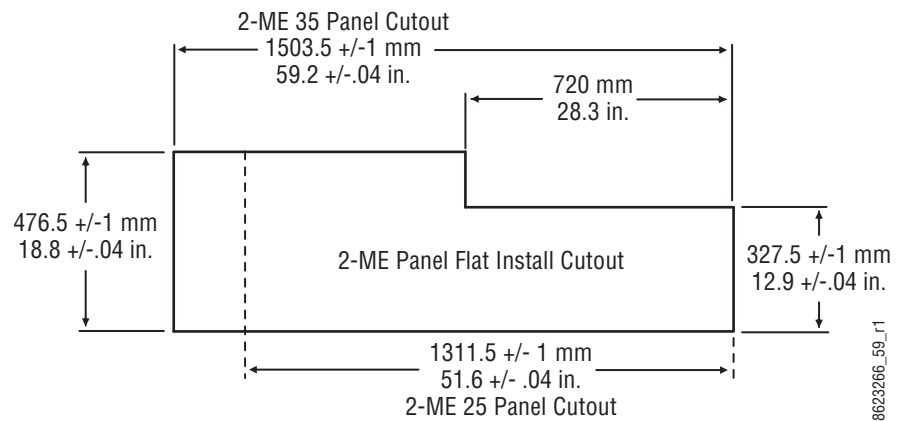

2-ME Control Panel Cutout Dimensions, Flat Installation

Control Surface Installation  
 2-ME 35 Control Panel, Flat Assembly with Local Aux

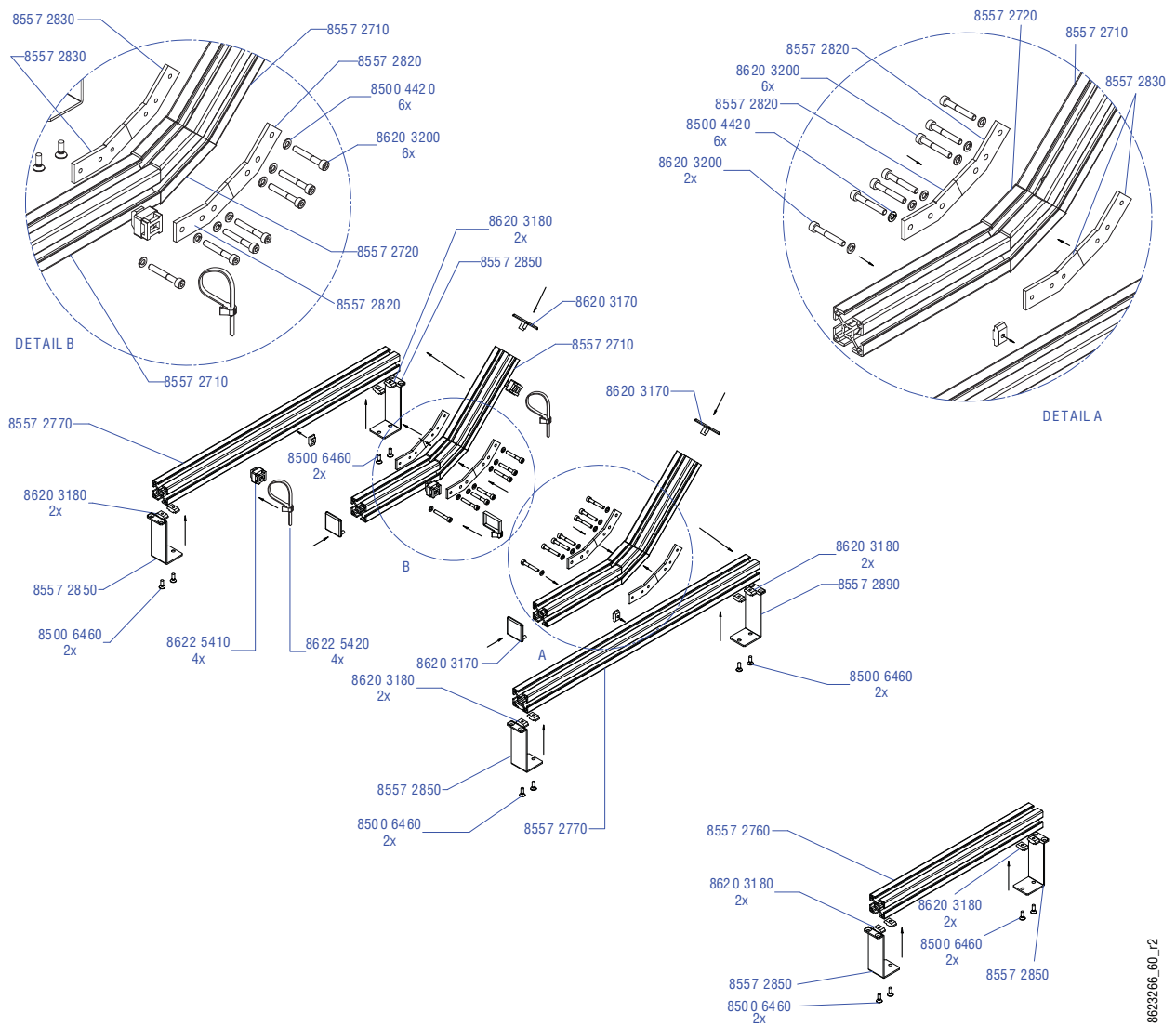

2-ME Support Structure, Flat Installation

8623266\_60\_T2

## 2-ME 35 Control Panel, Flat without Local Aux

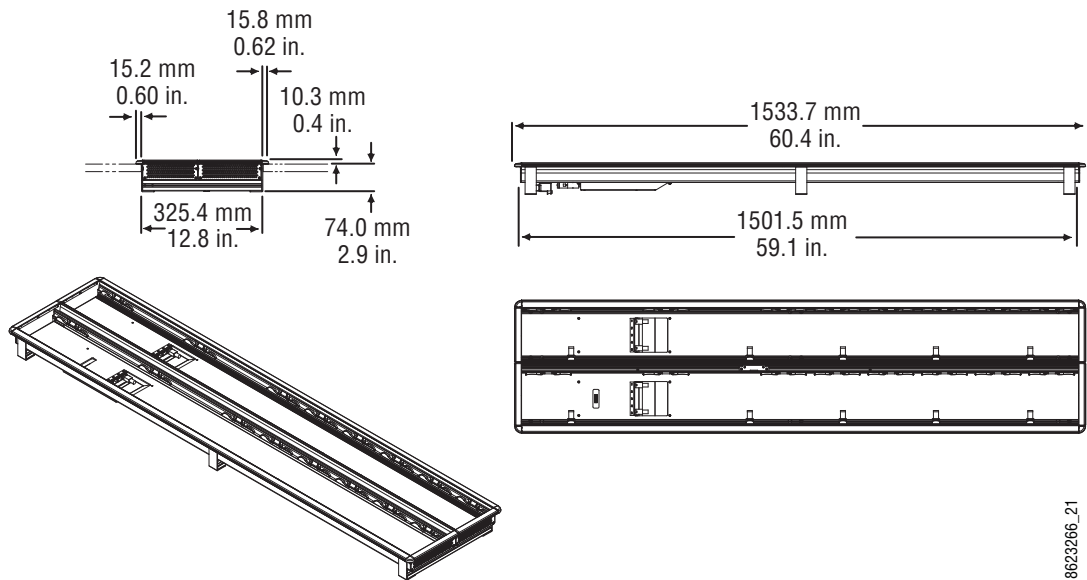

2-ME 35 Control Panel Dimensions, Flat Installation

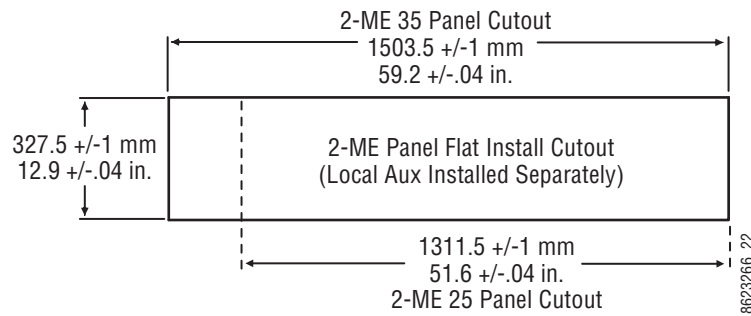

2-ME Control Panel Cutout Dimensions, Flat Installation

Control Surface Installation  
2-ME 25 Control Panel

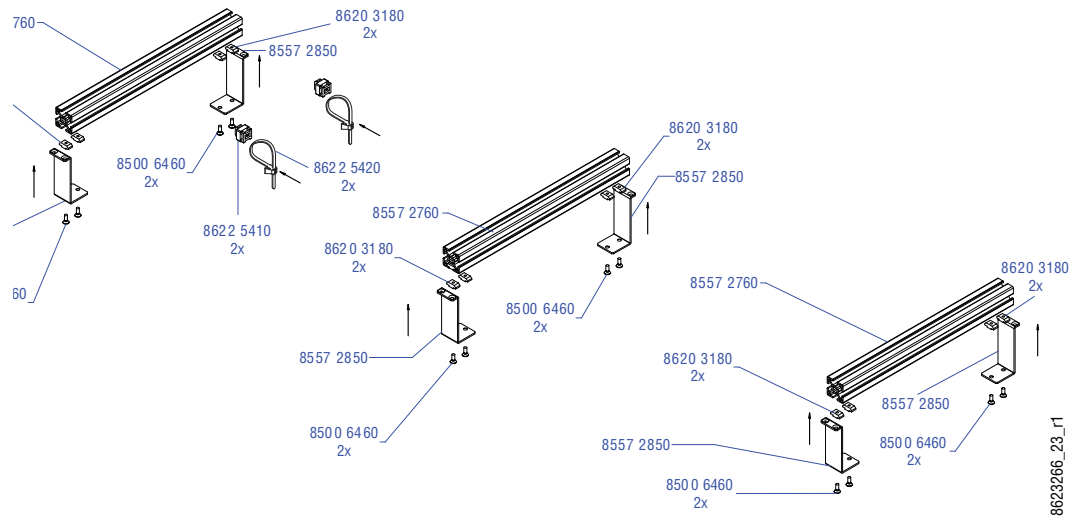

2-ME Support Structure, Flat Installation, w/o Local Aux Stripe

## 2-ME 25 Control Panel

Control panels with 25 source selection buttons are narrower in width, but otherwise have the same dimensions as 35 source button models.

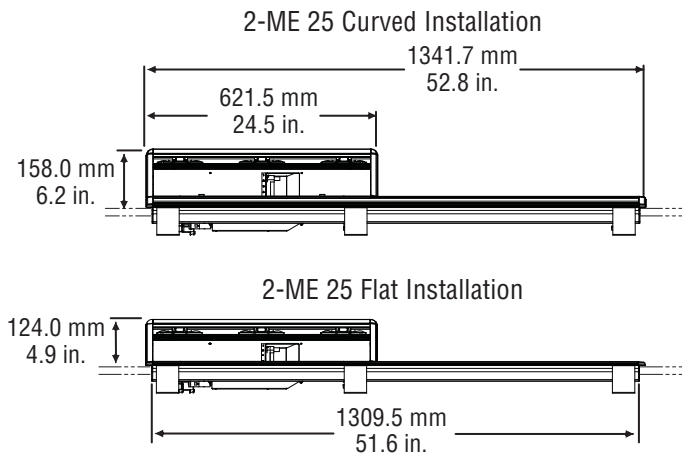

2-ME 25 Control Panel Dimensions



### 1-ME 15 Control Panel

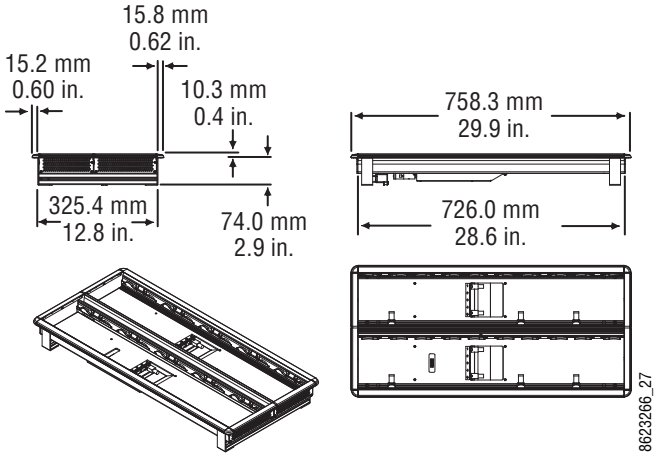

1-ME 15 Control Panel Dimensions, Flat Installation

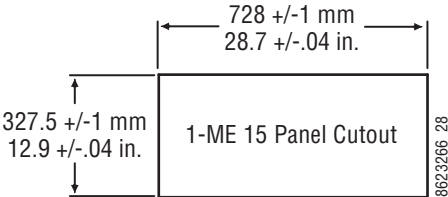

1-ME 15 Control Panel Cutout Dimensions, Flat Installation

Control Surface Installation  
 Separately Mounted Local Aux Stripe (35 & 25 Models)

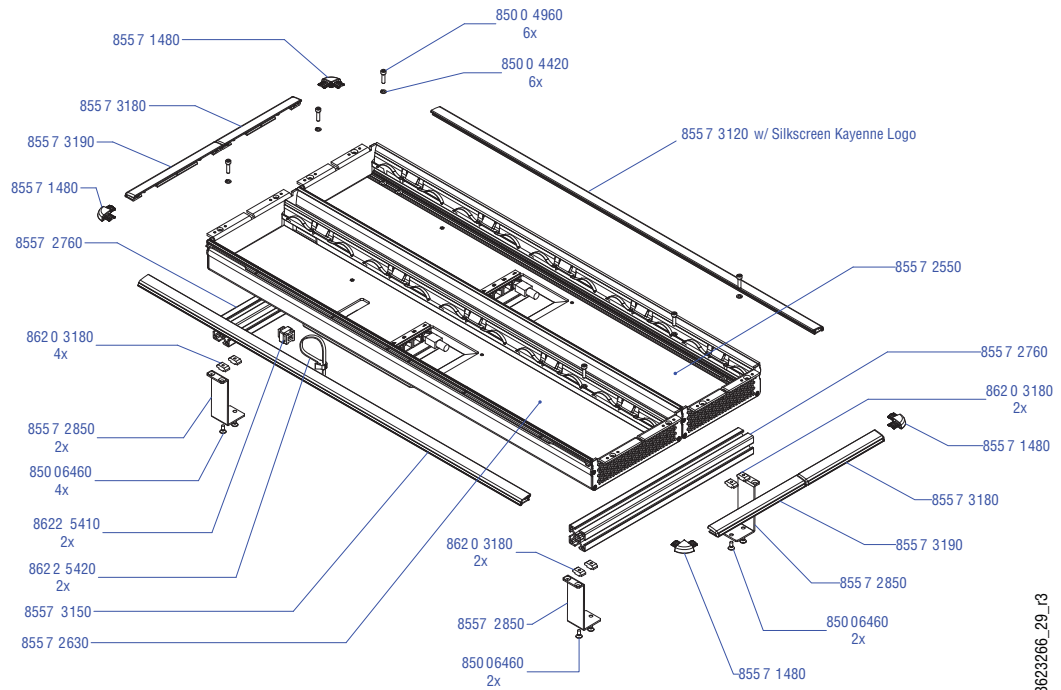

1-ME Support Structure and Trim, Flat Installation

8623266\_29\_r3

Separately Mounted Local Aux Stripe (35 & 25 Models)

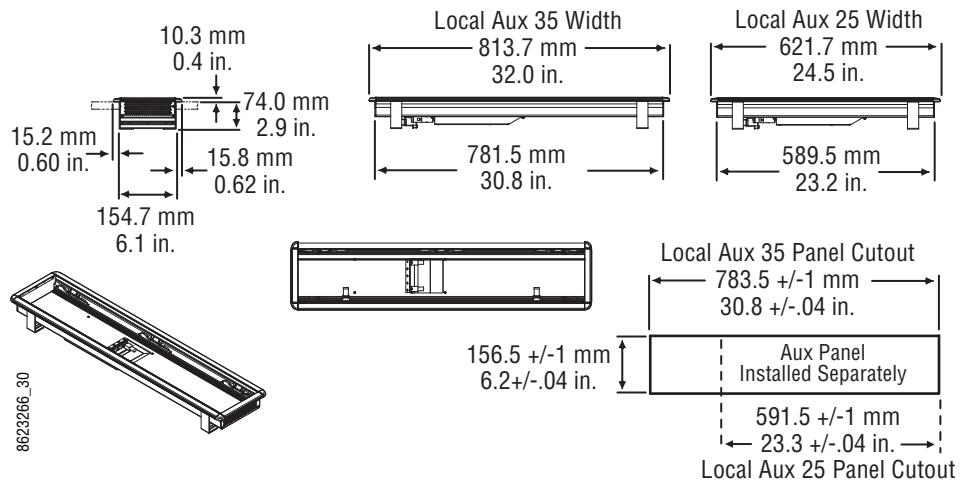

Local Aux Stripe Separate Installation Dimensions

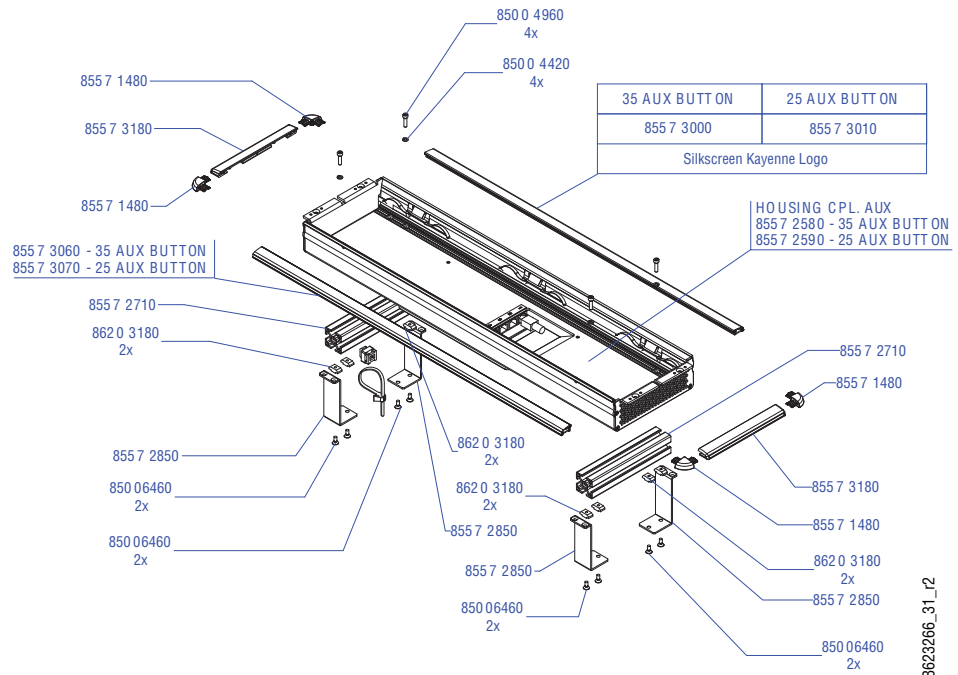

*Local Aux Stripe Support Structure, Tray, and Trim*

## Control Panel Stripe-PCU Connections

Connectors on the outside bottom of the Stripe connect to the PCU, using a special multi-pin cable that carries both power and communications (see [Kayenne K-Frame System Cabling](#)).

## Touch Screen Menu Panel Installation

### Menu Panel Dimensions

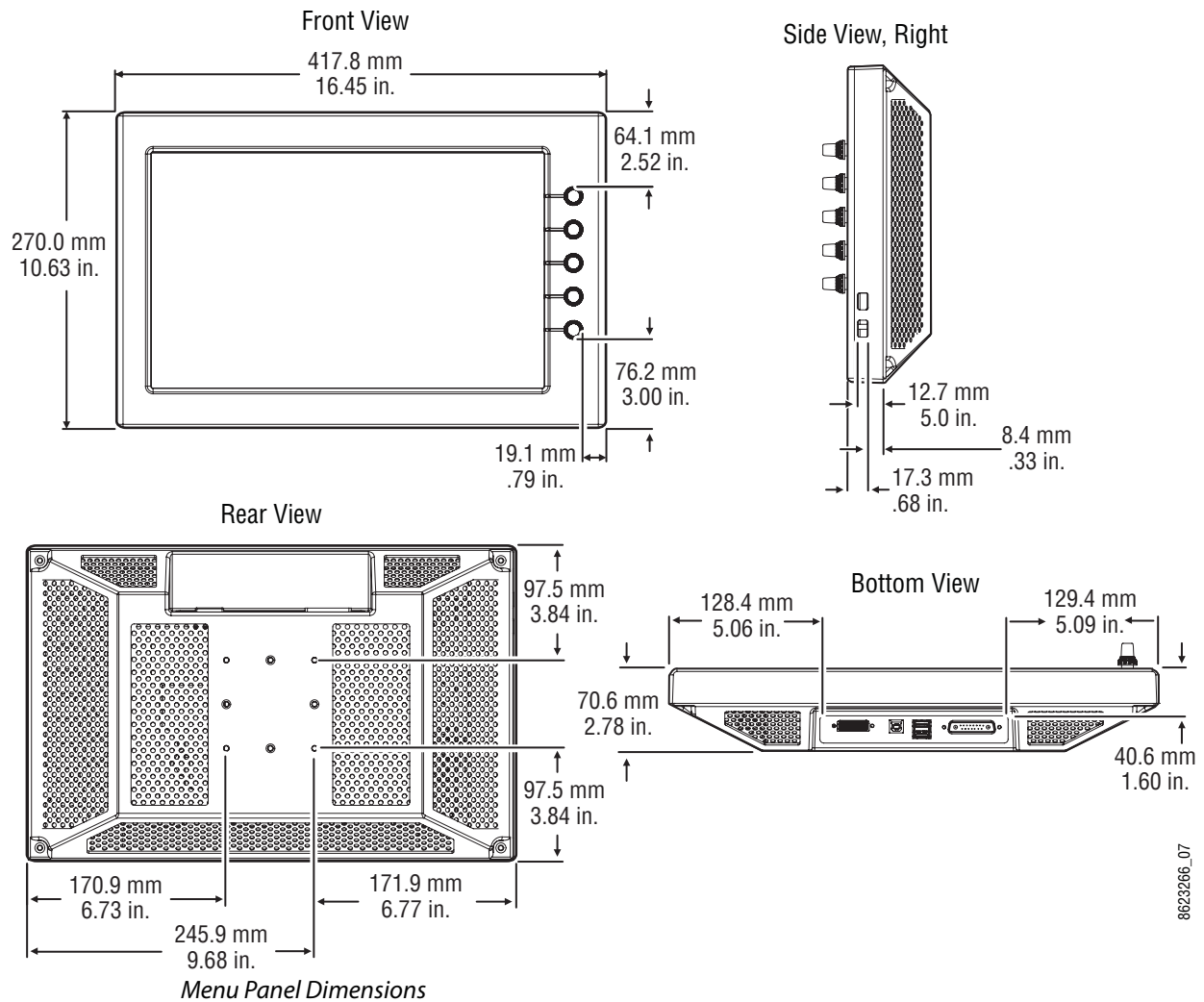

### Menu Panel Connectors

The Kayenne Menu Panel's processor is located in the PCU. The Menu Panel connects to the PCU with a special multi-pin cable that carries both power and communications signals.

**CAUTION:** Do not connect or disconnect the multi-pin cables linking a Kayenne Control Panel tray and PCU while the PCU is powered up. Damage to the equipment can result.

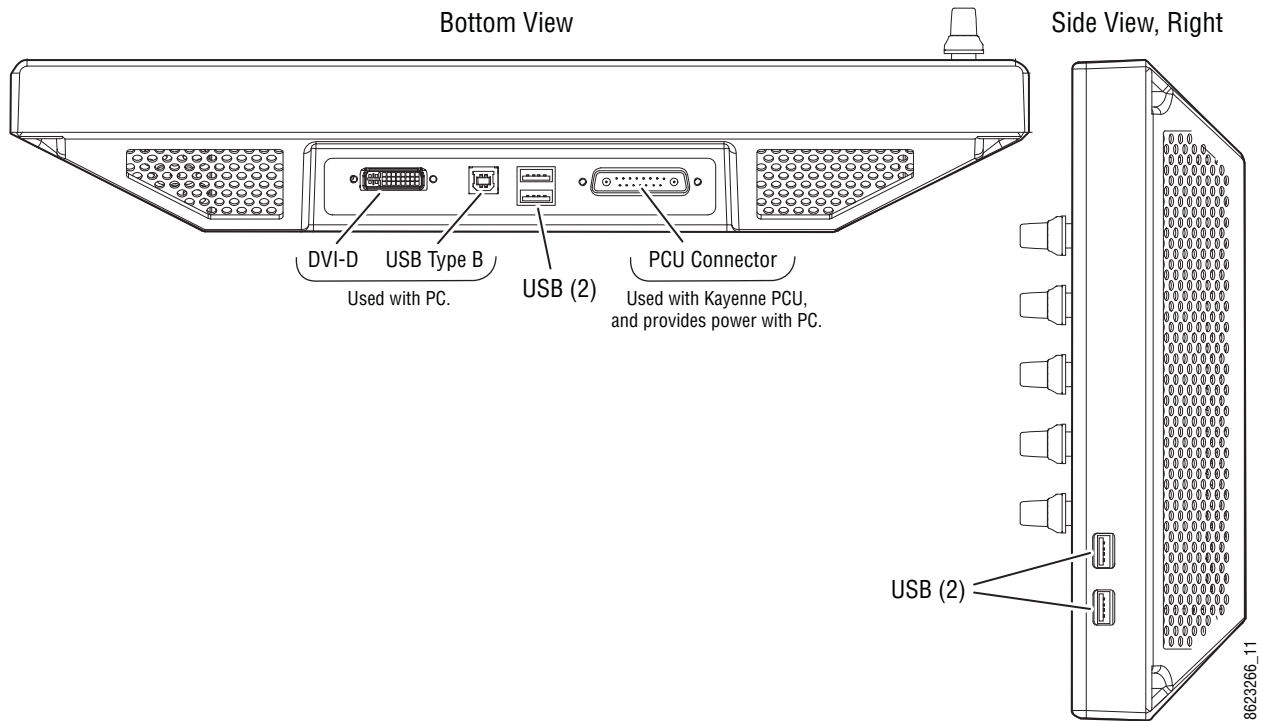

#### Menu Panel Connections

### Menu Panel Cooling

**CAUTION:** Do not install the Menu Panel into an enclosed space. Passive air movement is required for cooling.

The Kayenne Menu Panel is externally powered and does not have internal cooling fans. The electronics are convection cooled through perforations in the rear of the Menu Panel chassis. Mounting the panel free-standing with the articulated arm allows maximum air movement, and is the preferred installation method. If an alternative method is used, ensure that all vents are unobstructed and adequate airflow is available.

### Menu Panel Articulated Arm Installation

The Kayenne Menu Panel has VESA 75 threads on the back that can be used to mount the Menu Panel to the supplied articulated arm, or any VESA compliant mounting system.

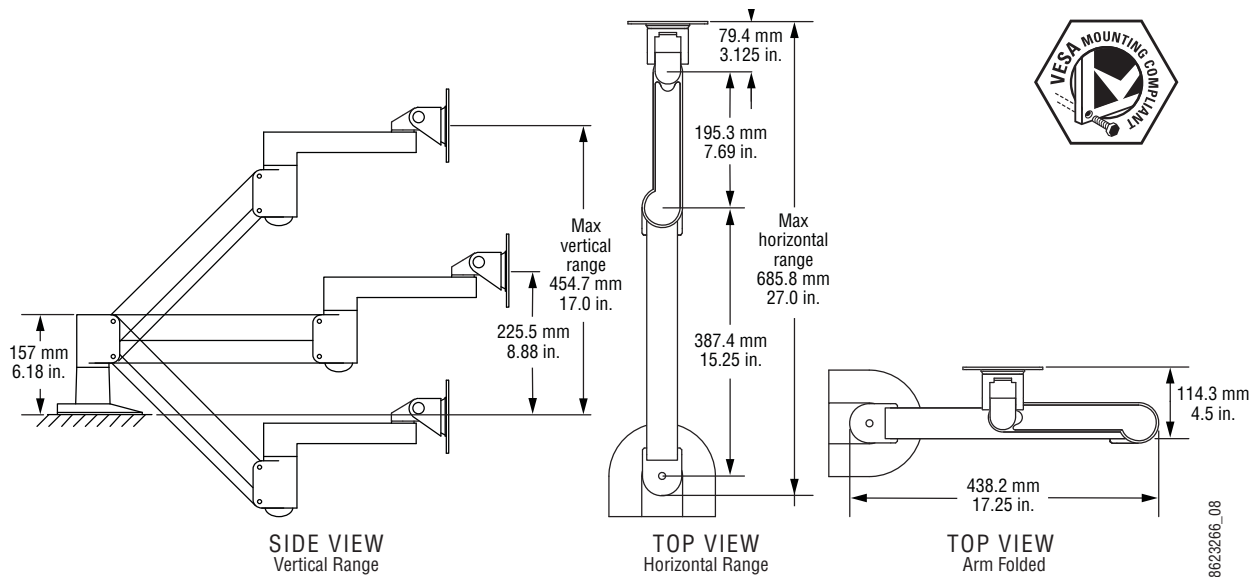

*Articulated Arm Range of Motion Dimensions*

The supplied articulated arm is equipped with a flex-mount system, permitting a variety of mounting options (table-top, wall mount, etc.). See the documentation provided with the articulated arm for specific installation instructions.

### **Additional Touch Screen Menu Panel Using PCU**

An additional Touch Screen Menu Panel, available as an option, requires a second Menu Panel processor board in the PCU. A multi-pin cable is provided with the option to supply power and signals to the Menu Panel.

### **Additional Touch Screen Menu Panel Using PC**

A Touch Screen Menu Panel can be configured to operate without a PCU, using a PC. Communication between the Menu Panel and the K-Frame system is handled using the PC's Ethernet connection. A special power supply brick is required, which powers the Menu Panel through the PCU connector.

### **Menu Application on PC (Keyboard & Mouse)**

The Kayenne menu application can also be run on a standard PC, permitting mouse and keyboard control from a nearby laptop, or remote control of the K-Frame system from any location on the network. If a PC is used for Kayenne Menu operation, the PC's IP address must be set to a compatible value to work with the rest of the K-Frame system.

## **Karrera Control Surface**

A typical Karrera control surface has a Control Panel and a Karrera Menu on PC or Menu Panel option.

### 3-ME Karrera Control Panel Installation

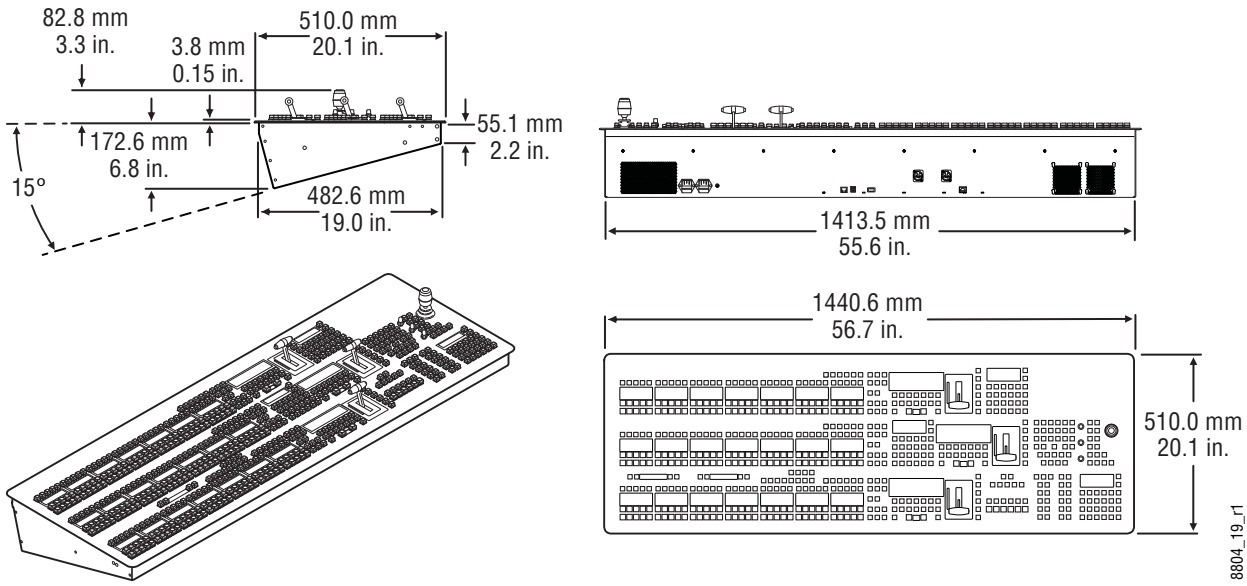

3-ME Karrera Control Panel Dimensions

Control Surface Installation  
 3-ME Karrera Control Panel Installation

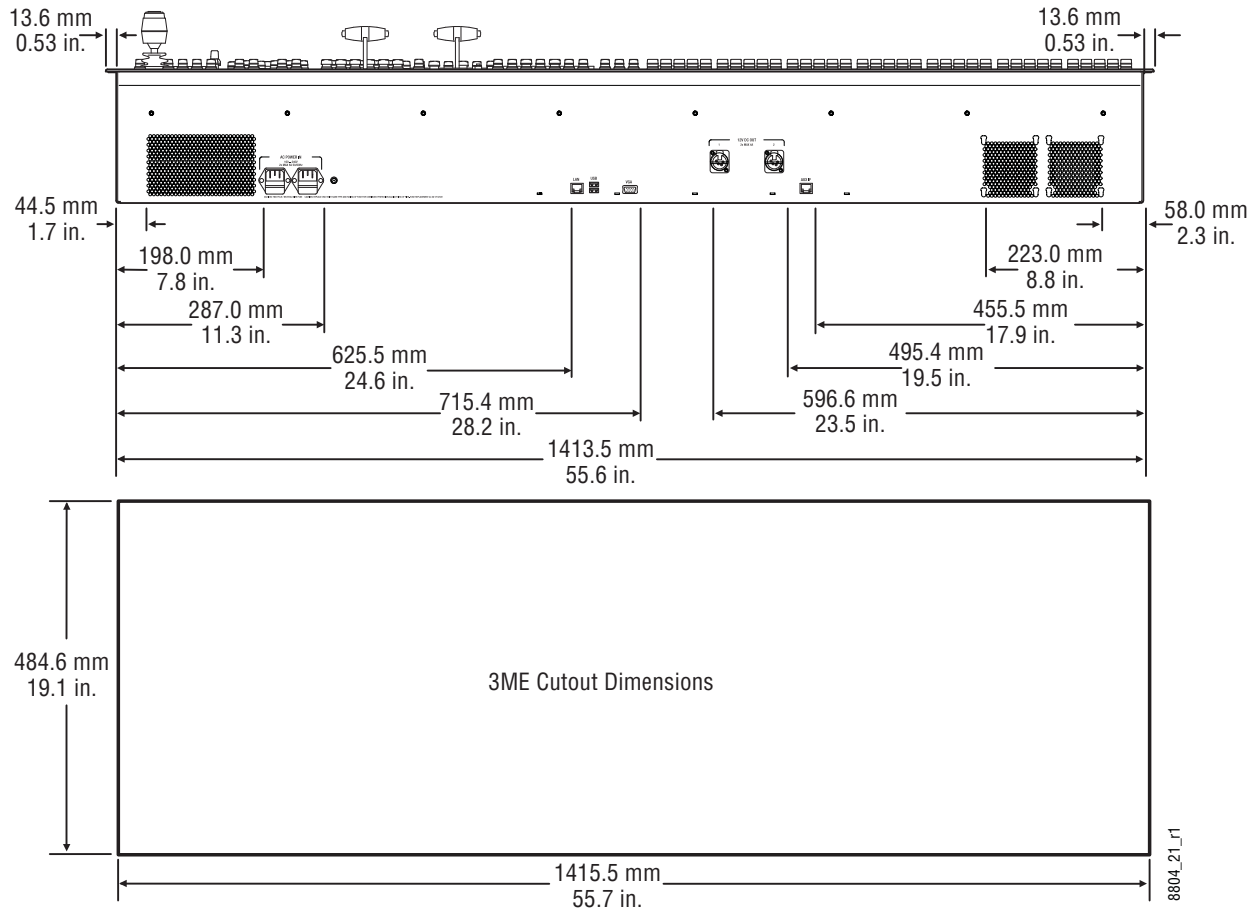

3-ME Karrera Control Panel Cutout Dimensions

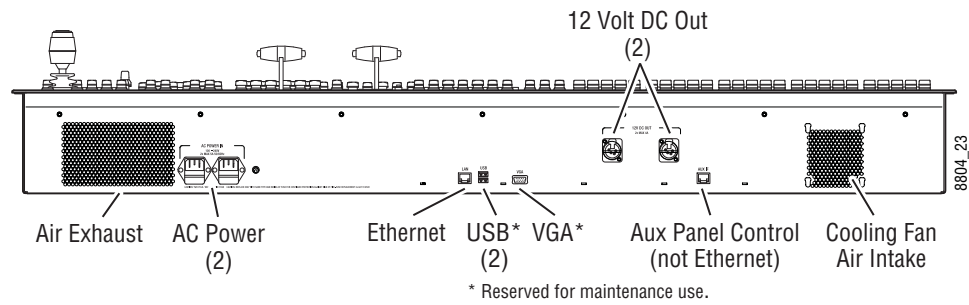

3-ME Karrera Control Panel Rear Connections

2-ME Karrera Control Panel Installation



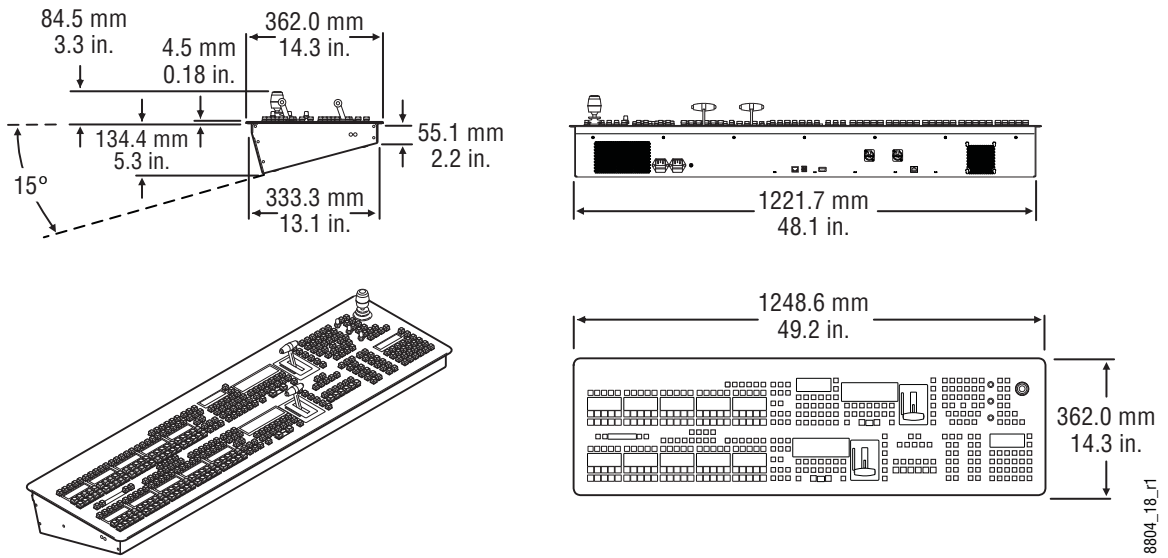

2-ME Karrera Control Panel Dimensions

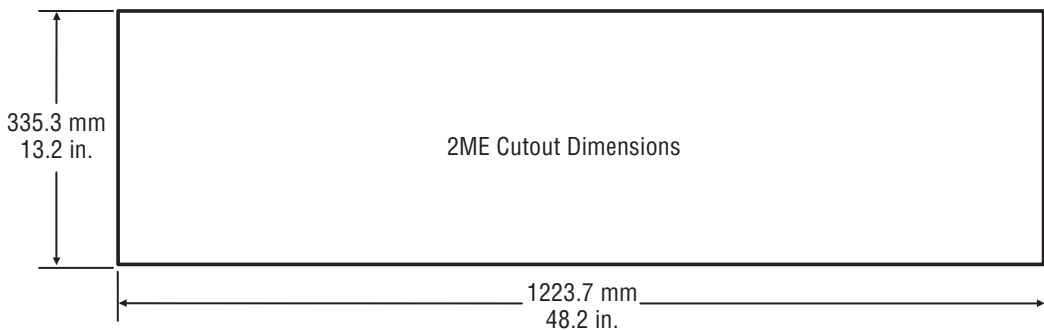
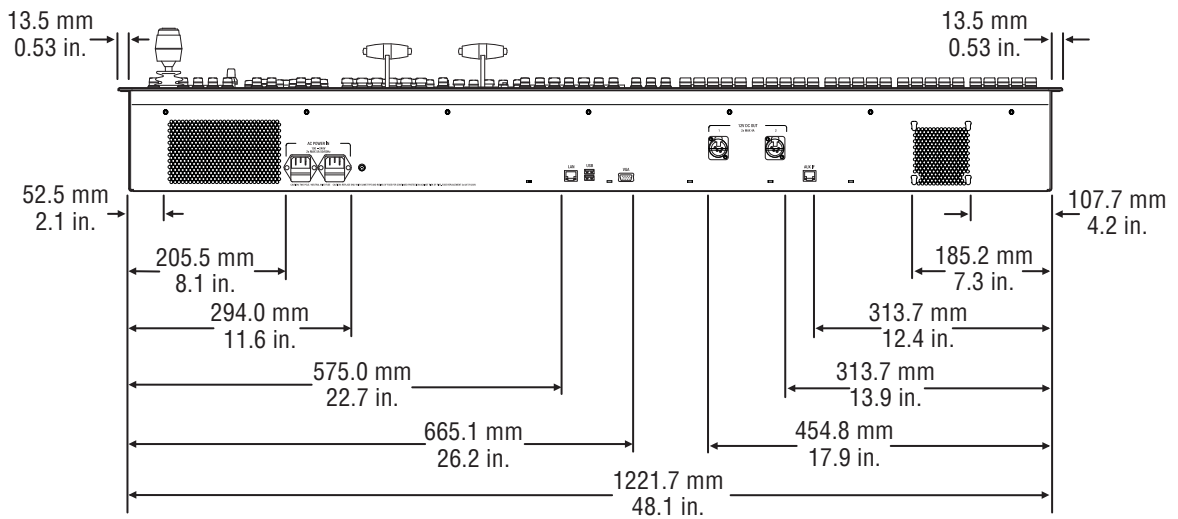

2-ME Karrera Control Panel Cutout Dimensions

8804\_18\_r1

8804\_20r1

Control Surface Installation  
 2-ME Compact Karrera Control Panel Installation

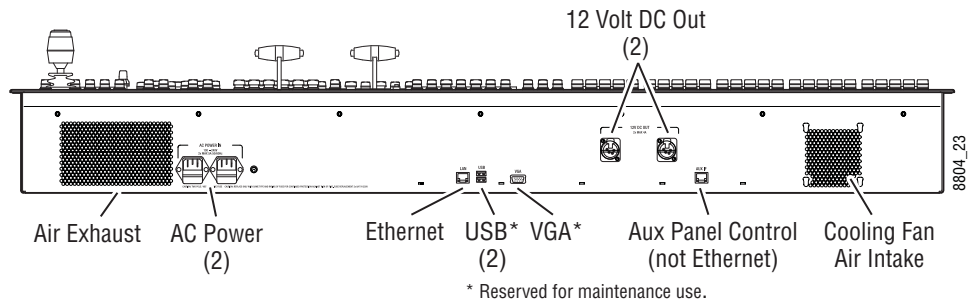

2-ME Karrera Control Panel Rear Connections

2-ME Compact Karrera Control Panel Installation

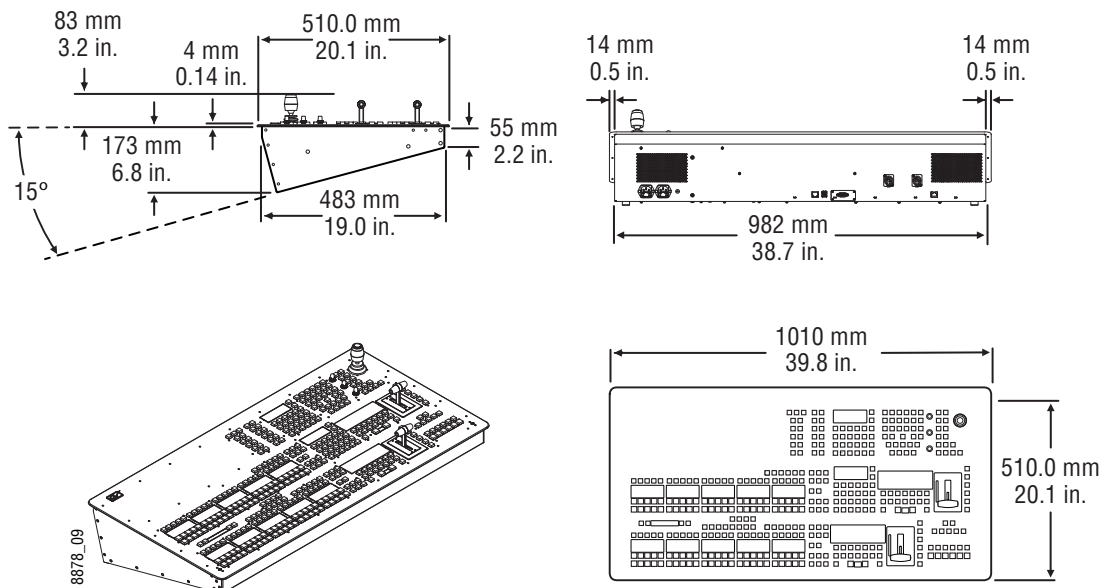

2-ME Compact Karrera Control Panel Dimensions

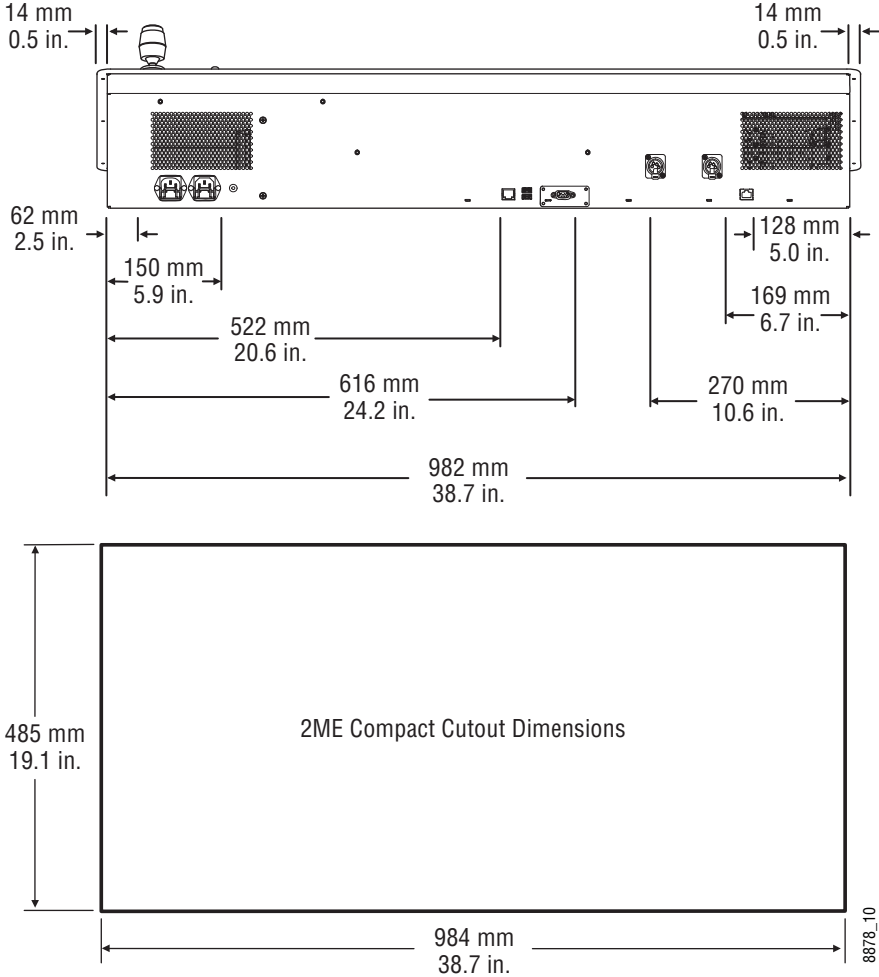

2-ME Compact Karrera Control Panel Cutout Dimensions

Figure 4. 2-ME Compact Karrera Control Panel Rear Connections

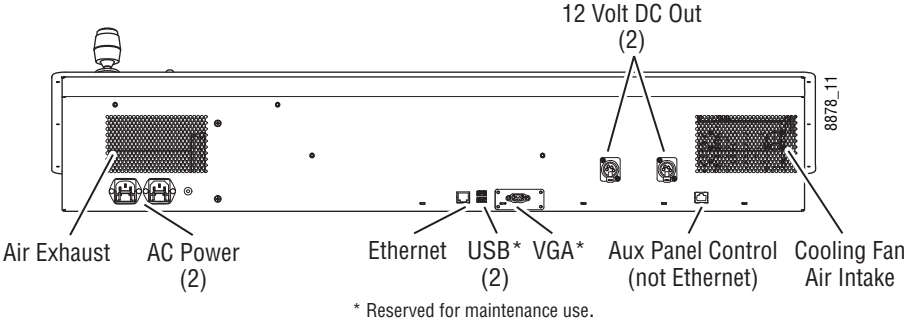

Karrera Menu on User PC Installation

The Karrera Menu application can be installed on a user PC, which can be configured with the Karrera network to provide a primary or additional control point to the Karrera system.

**CAUTION:** Access to the user PC should be controlled when the Karrera system is in use, to prevent accidental changes to Karrera system operations.

## PC Requirements

The PC running the Karrera Menu application should have at least 2 GB RAM, a 2 GHz processor, 500 MB available hard disk space, 1280 x 1024 minimum screen resolution, and be running Windows XP with Service Pack 3 or Windows 7. The PC must also support 10Base-T or 100Base-T Ethernet and high-speed USB.

## Macintosh Computer Operation

Macintosh computers with Intel processors can run Windows programs (including the Karrera Menu application), using the Apple computer Boot Camp mechanism (booting into the Windows OS partition), or by running a Virtual Machine (VM). VM operation allows running two different operating systems on the same computer simultaneously, with instantaneous switching between the two environments. Parallels and VMWare are two commercially available VM solutions for Mac. The Mac hardware and VM created must meet the PC requirements listed above.

In all cases, a Windows OS will need to be installed on the Mac (into the Boot Camp partition or as a VM), and the Windows environment will need to be configured (including I/O device access, IP addresses, etc.). When a working Windows environment exists on the Mac, the Grass Valley Switcher Installer program can be used to install the Karrera Menu application into the Mac's Windows environment, and the application can operate with a Karrera system the same as if it was running on a Windows PC.

## Hardware Installation

Connect a Category 5 Ethernet cable from the user PC to the Karrera network, either directly into an available port on the Karrera frame, or with a customer provided Ethernet switch, or indirectly via a properly configured network gateway. The PC's IP address must be compatible with the Karrera system network.

## Menu on User PC Software Installation

Karrera Menu Panel software is included on the Karrera Software USB stick, and is installed using the standard Grass Valley Switcher software installation process. The Karrera Menu application requires Microsoft .NET Framework software, which is also included on the USB stick.

If the correct version of the Microsoft .NET Framework software is already present on your PC, the Karrera Menu application can be installed using the standard software update process.

If .NET Framework software is not present, it can be installed by running the executable file located in the DotNet folder on the Karrera Software USB stick.

Refer to the separate *Karrera Release Notes* for specific software installation information.

## **User PC Configuration**

Windows Firewall, and any other firewall security software (e.g. Officescan Personal Firewall), must be disabled to use the Switcher Installer program or NetConfig on a user PC.

## **Optional Touch Screen Menu Panel Installation**

The Touch Screen Menu Option consists of:

- Touch Screen Menu,
- Fanless PC,
- Articulated arm support,
- Two mounting brackets (“U” and “T” shaped),
- Two power supply bricks, and
- associated cables and screws.

## Menu Panel Dimensions

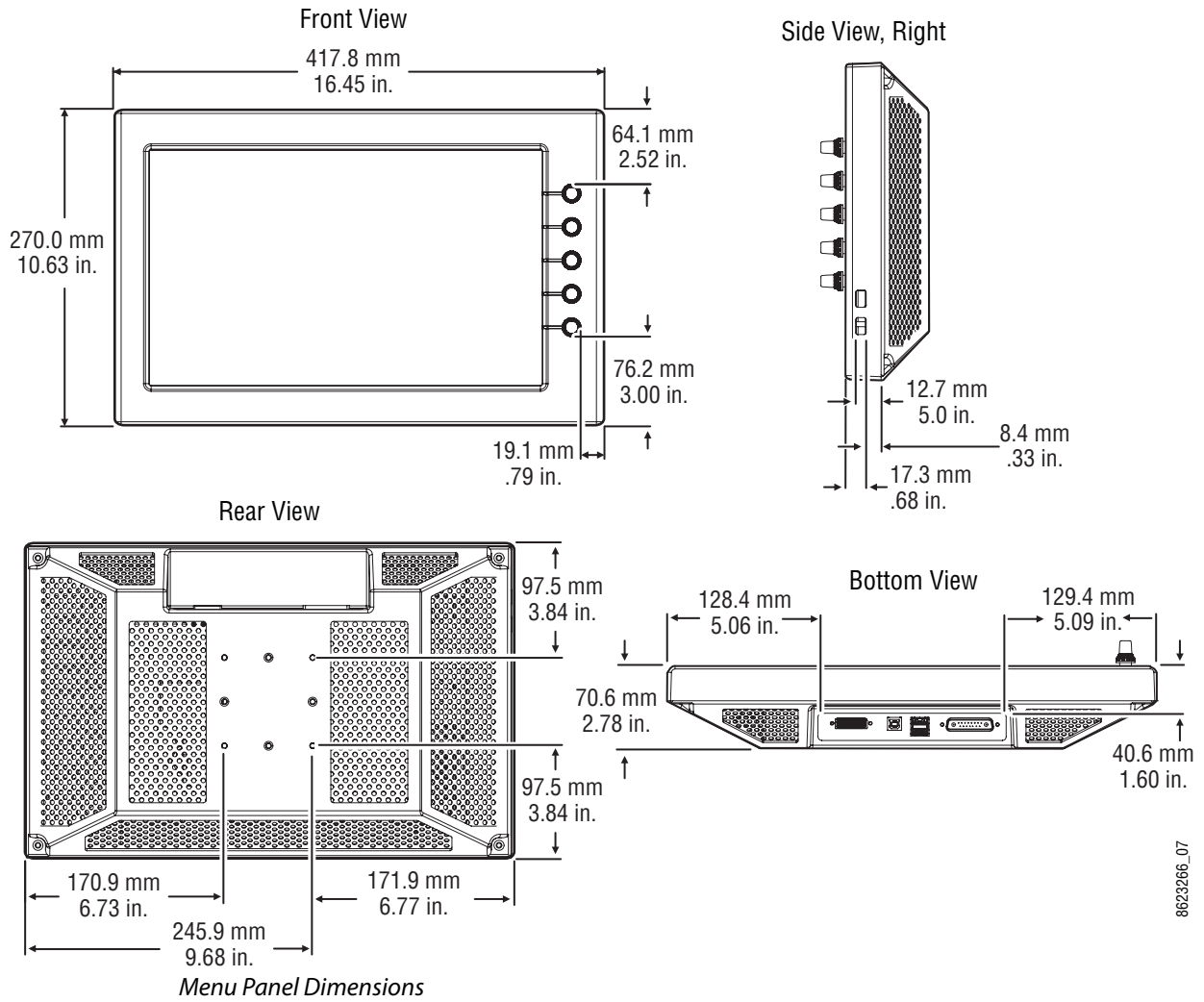

8623266\_07

## Menu Panel Connectors

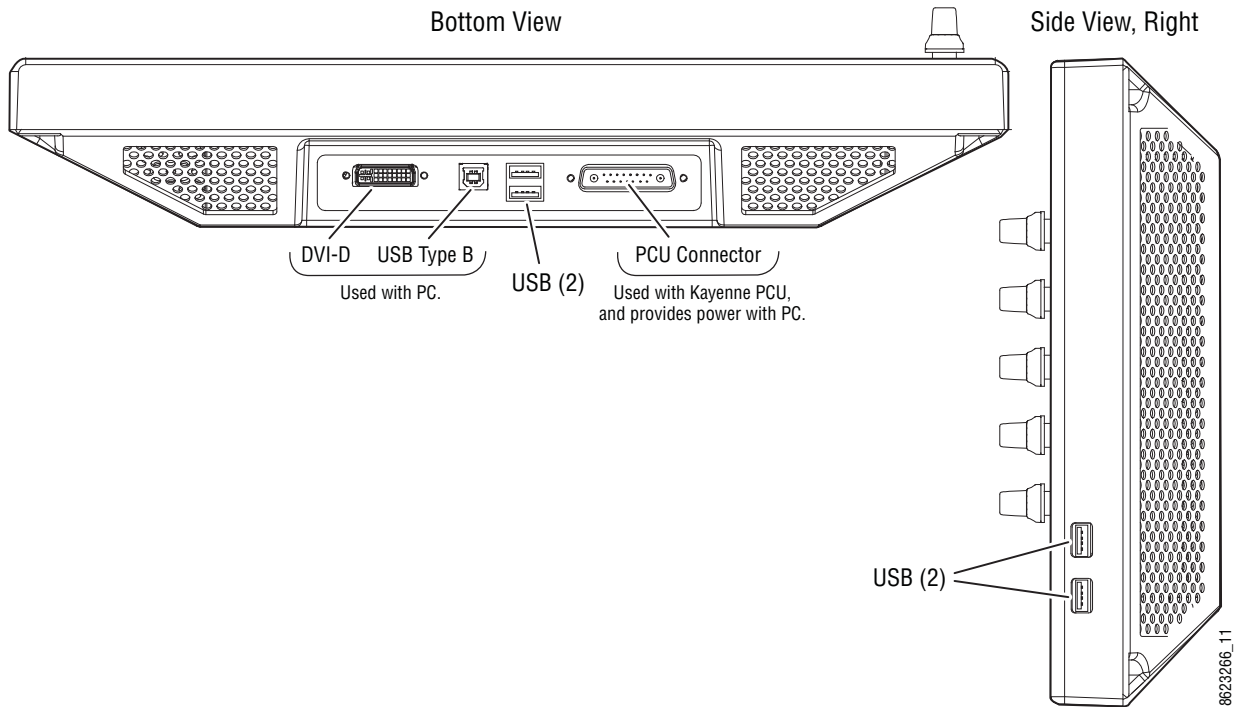

*Menu Panel Connections*

## Menu Panel Cooling

**CAUTION:** Do not install the Menu Panel into an enclosed space. Passive air movement is required for cooling.

The Menu Panel is externally powered and does not have internal cooling fans. The electronics are convection cooled through perforations in the rear of the Menu Panel chassis. Mounting the panel free-standing with the articulated arm allows maximum air movement, and is the preferred installation method. If an alternative method is used, ensure that all vents are unobstructed and adequate airflow is available.

## Fanless PC Dimensions and Connectors



*Fanless PC Dimensions*

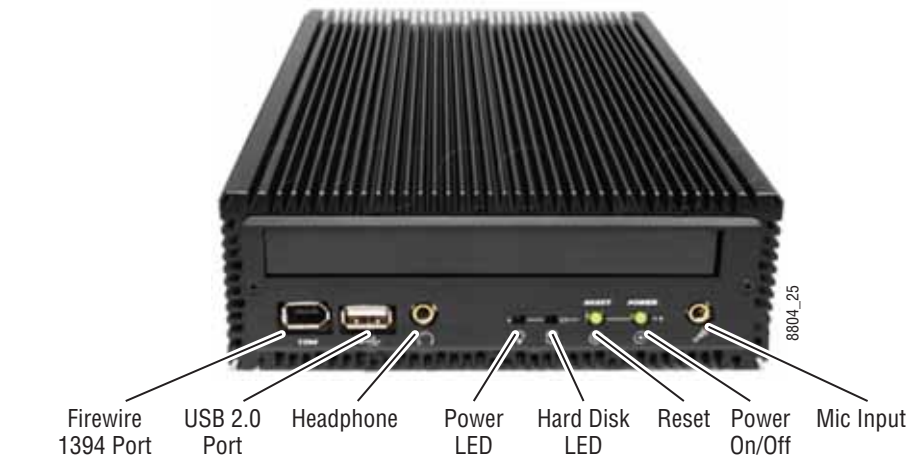

*Fanless PC Front Connectors*





Fanless PC Rear Connectors

## Menu Panel Articulated Arm Installation

The Menu Panel has VESA 75 threads on the back that can be used to mount the Menu Panel to the supplied articulated arm, or any VESA compliant mounting system.

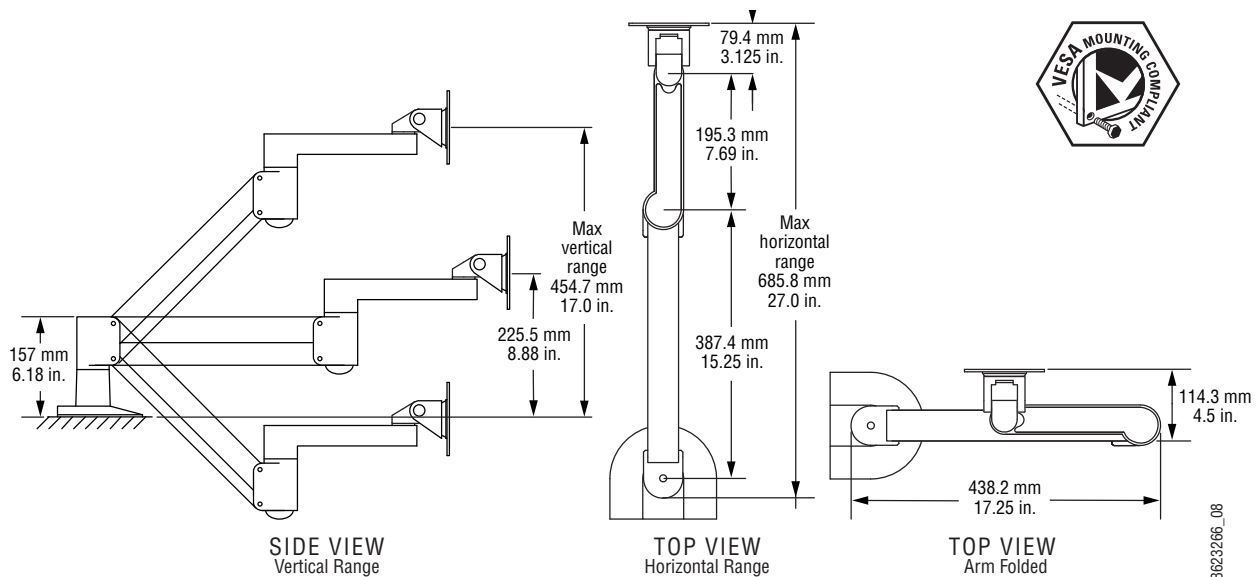

Articulated Arm Range of Motion Dimensions

The supplied articulated arm is equipped with a flex-mount system, permitting a variety of mounting options (table-top, wall mount, etc.). See the documentation provided with the articulated arm for specific installation instructions.

## Menu Panel Hardware Installation With Articulated Arm

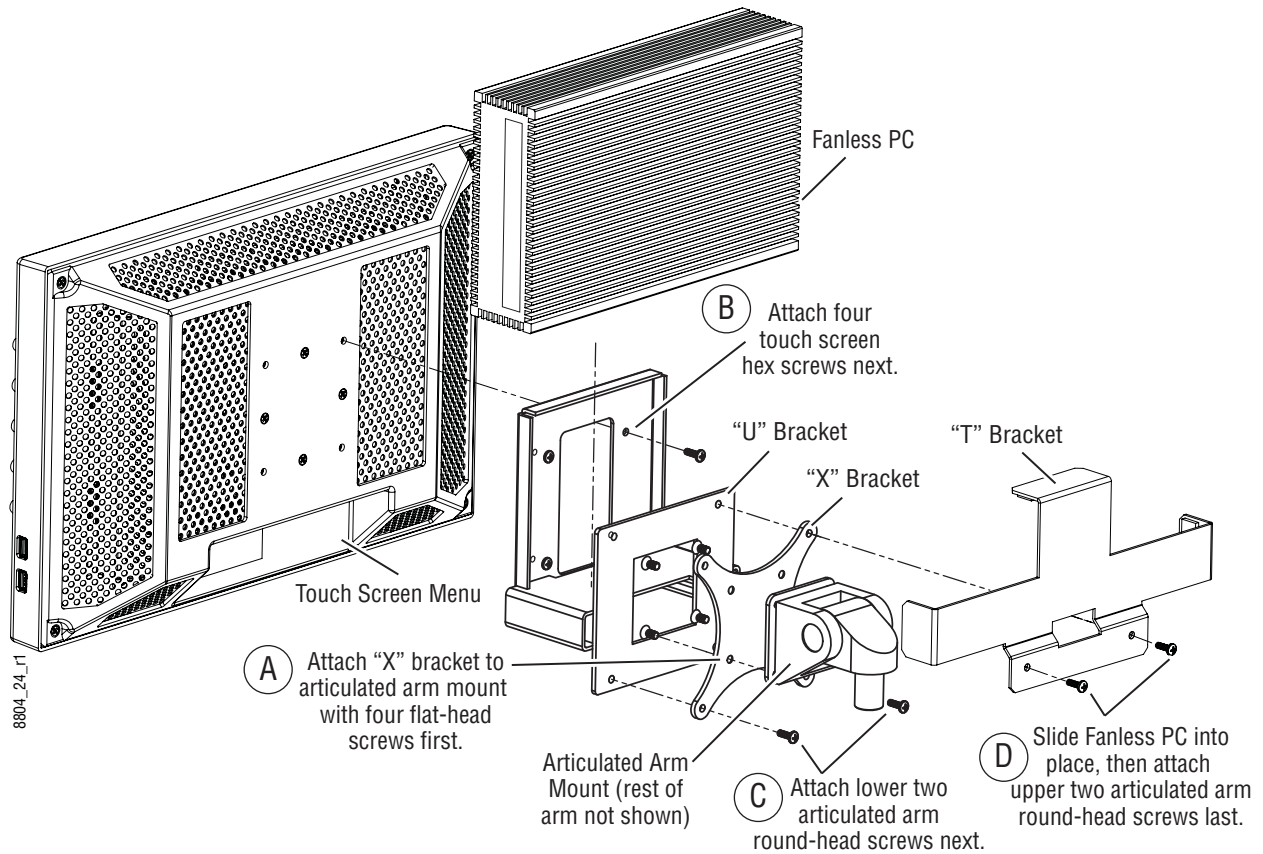

*Fanless PC Mounting Bracket Assembly*

## Wall Mounting Without Articulated Arm

For flat mounting directly to a vertical surface without using the articulated arm, two #10 screw sized washers (2.5 mm/0.10 in. thick) can be used at the lower two “U” bracket screw locations.

# Optional Local Aux Panel Installation

## Local Aux Panel Dimensions

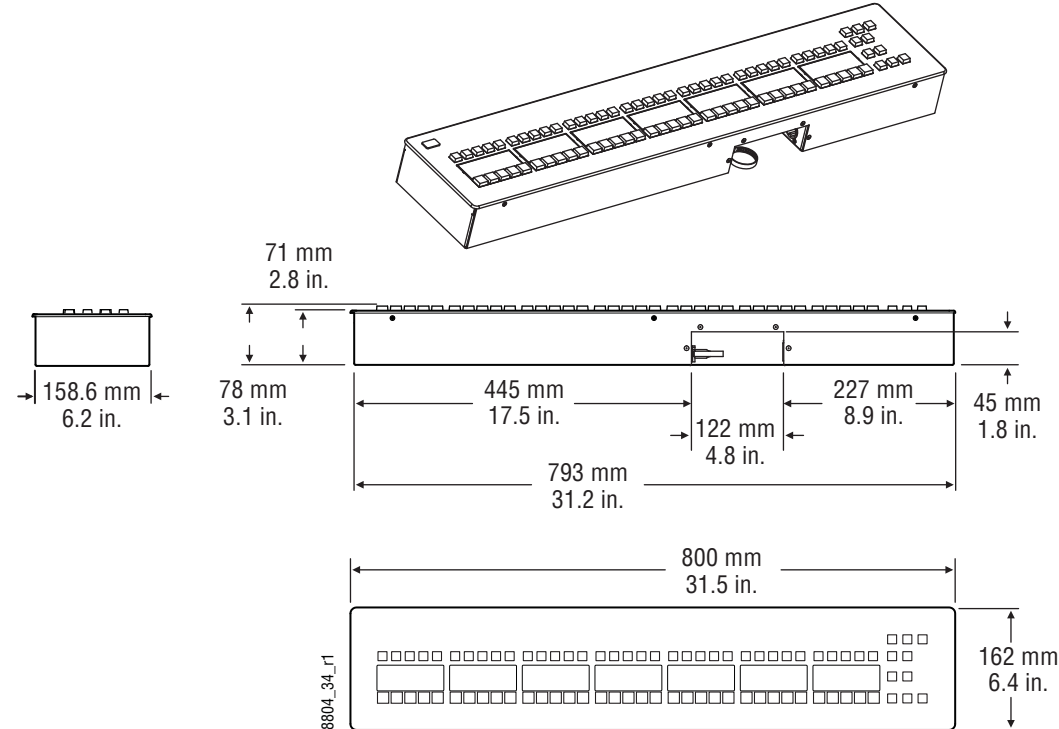

Local Aux 35 Panel Dimensions

## Local Aux 25 Panel Dimensions

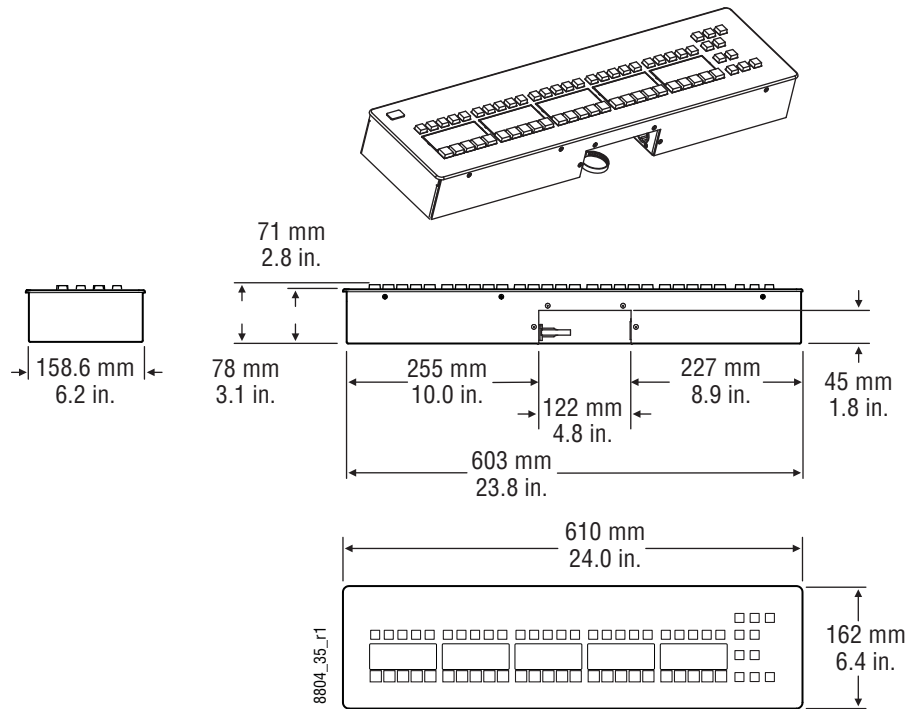

Local Aux 25 Panel Dimensions

## Local Aux Panel Installation Options

### Rear Screw Hole Dimensions

Two sets of brackets are provided with the Local Aux Panel, one intended for use in mounting into a tabletop cutout, and the other for mounting on a tabletop surface. Both brackets connect to threaded holes located on the rear of the Local Aux Panel.

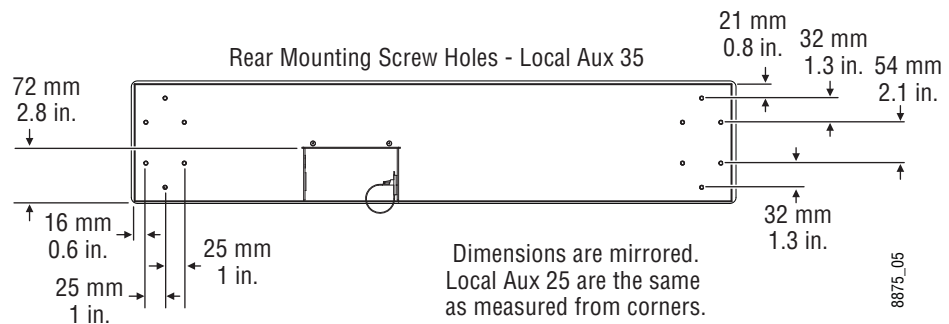

Local Aux Panel Rear Dimensions

## Tabletop/Backsplash Cutout Installation

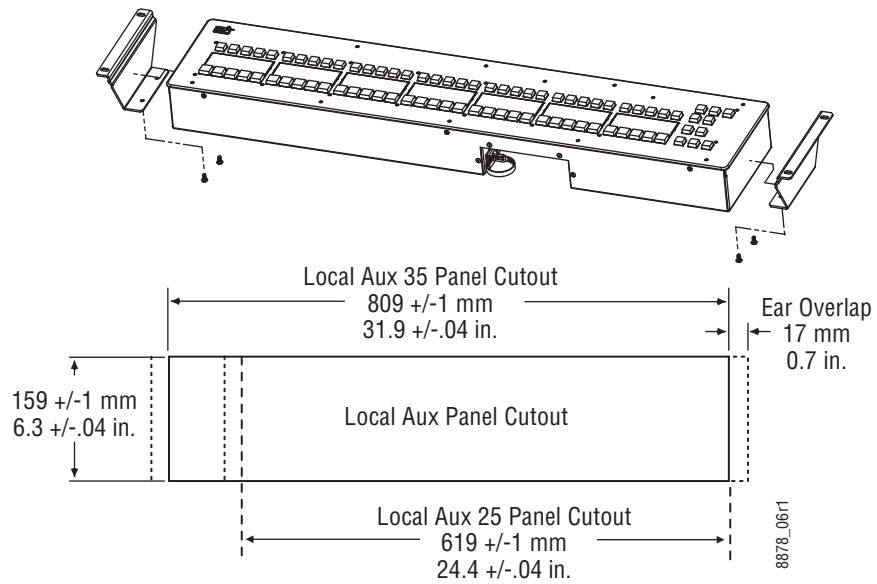

*Local Aux Panel Cutout Dimensions*

## Tabletop Bracket Installation: 2-ME and 3-ME Main Panels

The following suggested angle bracket mounting locations will orient the Local Aux panel with the buttons on the Main Panel, and leaves vertical clearance for removing the Main Panel from its cutout.

Control Surface Installation  
Local Aux 25 Panel Dimensions

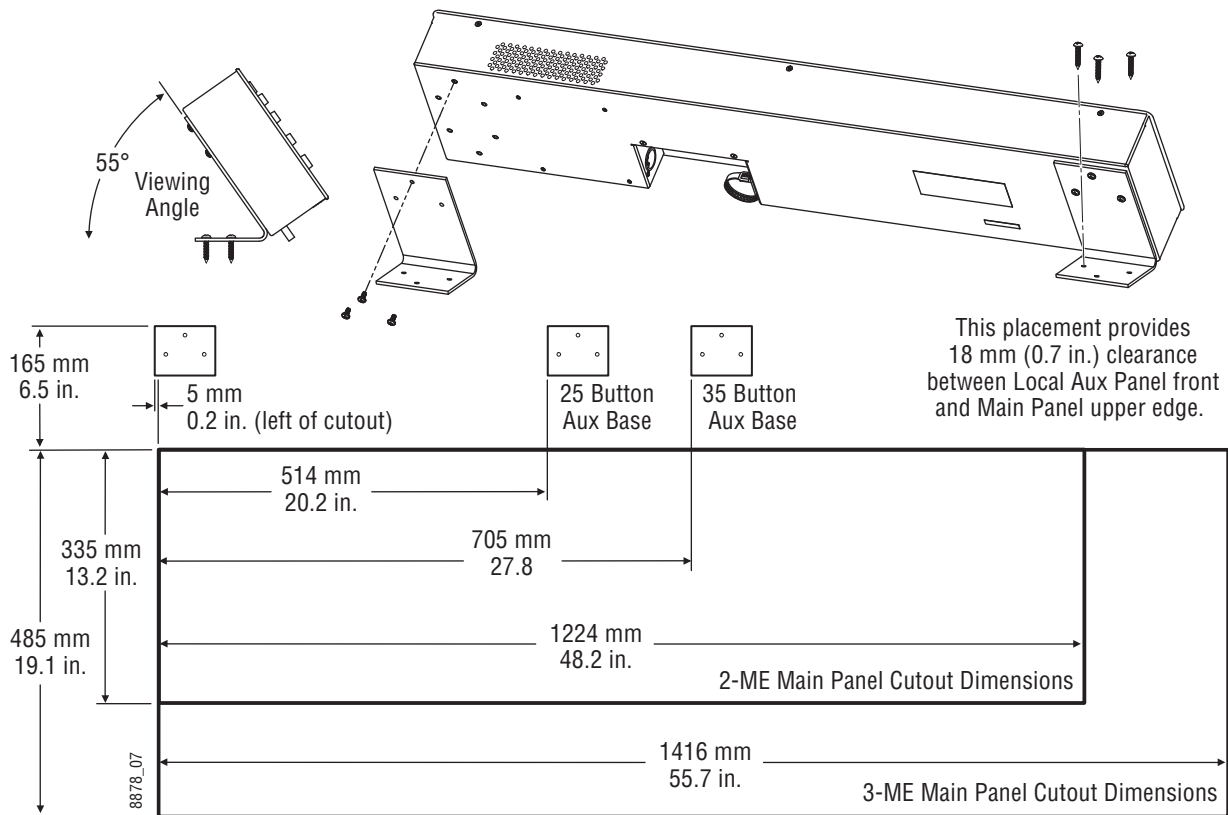

*Local Aux Panel Surface Mount Dimensions*

**Tabletop Bracket Installation: 2-ME Compact Panel**

The suggested bracket placement is different when mounting the Local Aux panel with a 2-ME Compact Control Panel.

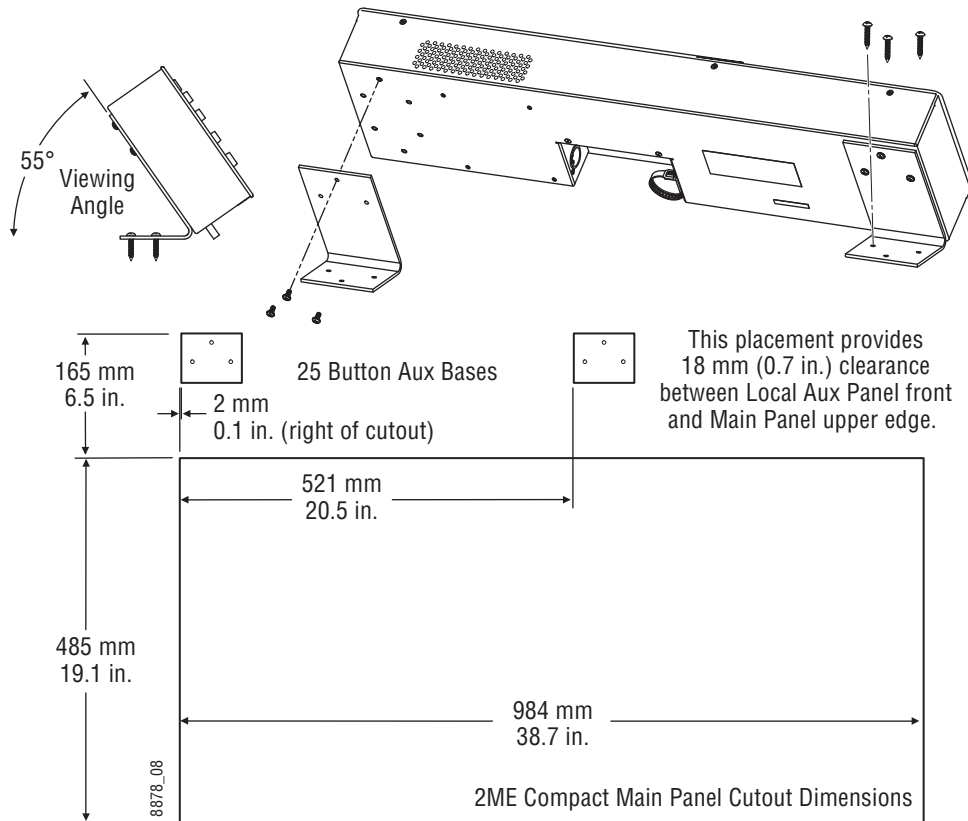

*Local Aux Panel Surface Mount Dimensions*

## GV Korona Control Surfaces

Use the GV Korona control surface cutout dimensions ([2-ME GV Korona Control Panel Cutout Dimensions](#), on page 62 and [1-ME GV Korona Control Panel Cutout Dimensions](#), on page 65) to prepare your consoles for GV Korona Control Panel installation.

## 2-ME GV Korona Control Panel Dimensions

**IMPORTANT:** All dimensions are in inches with millimeters in parenthesis.

Control Surface Installation  
 2-ME GV Korona Control Panel Dimensions

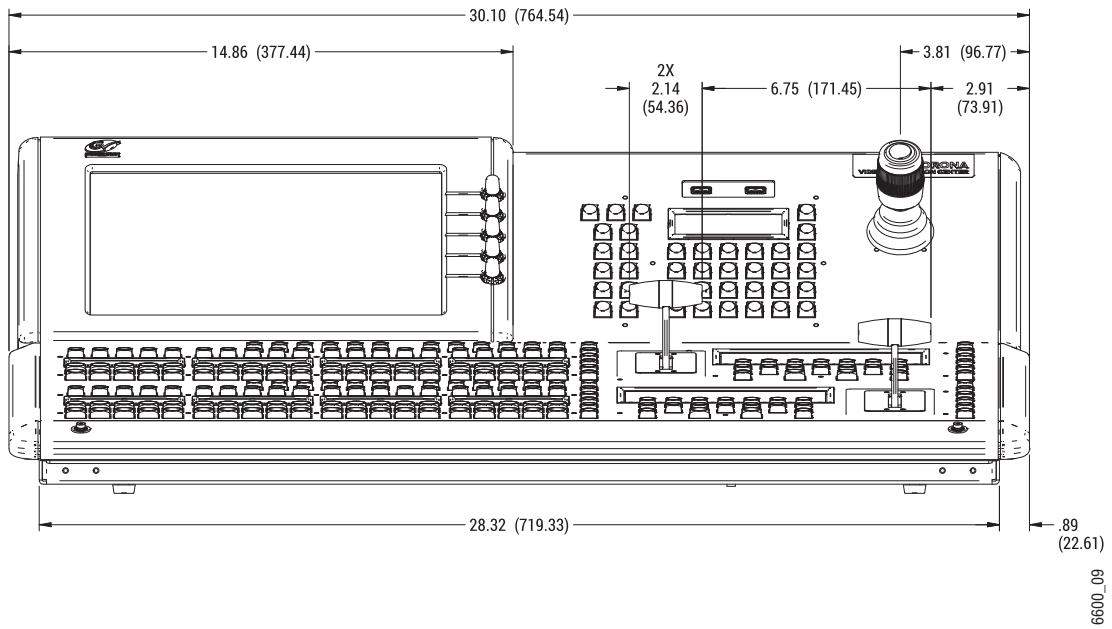

2-ME GV Korona Control Panel Front Dimensions

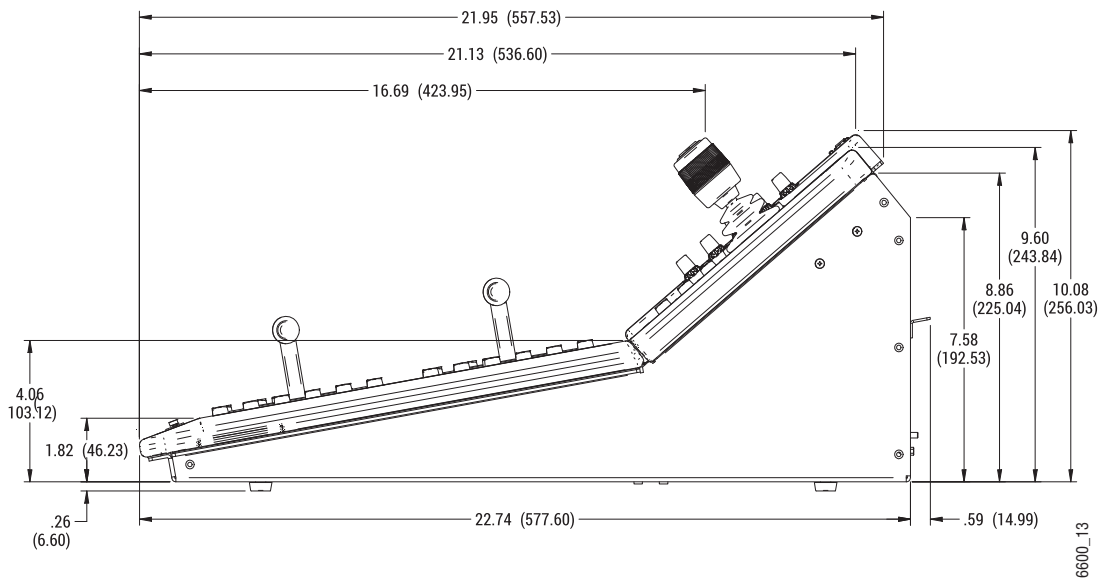

2-ME GV Korona Control Panel Side Dimensions



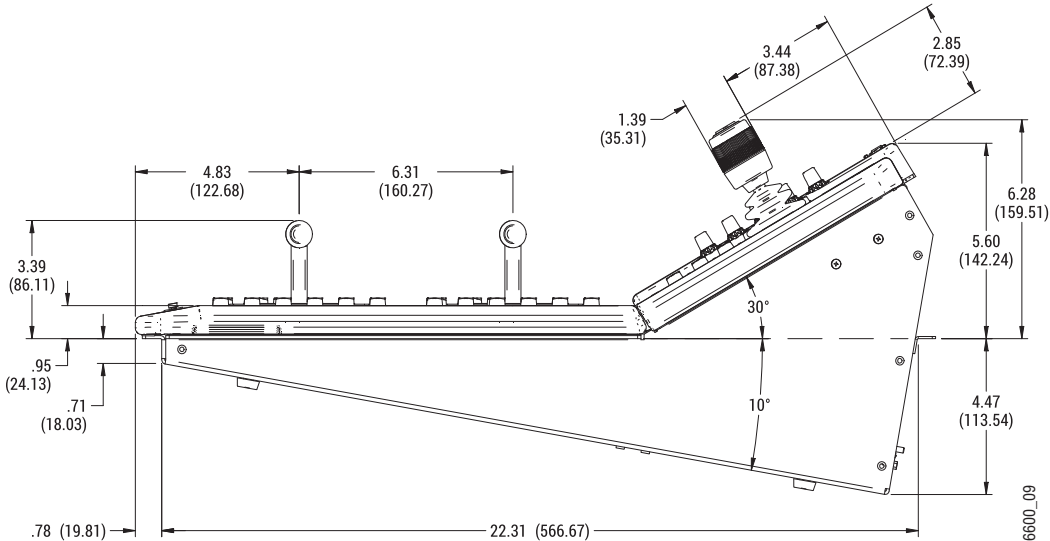

2-ME GV Korona Control Panel Mounting Dimensions

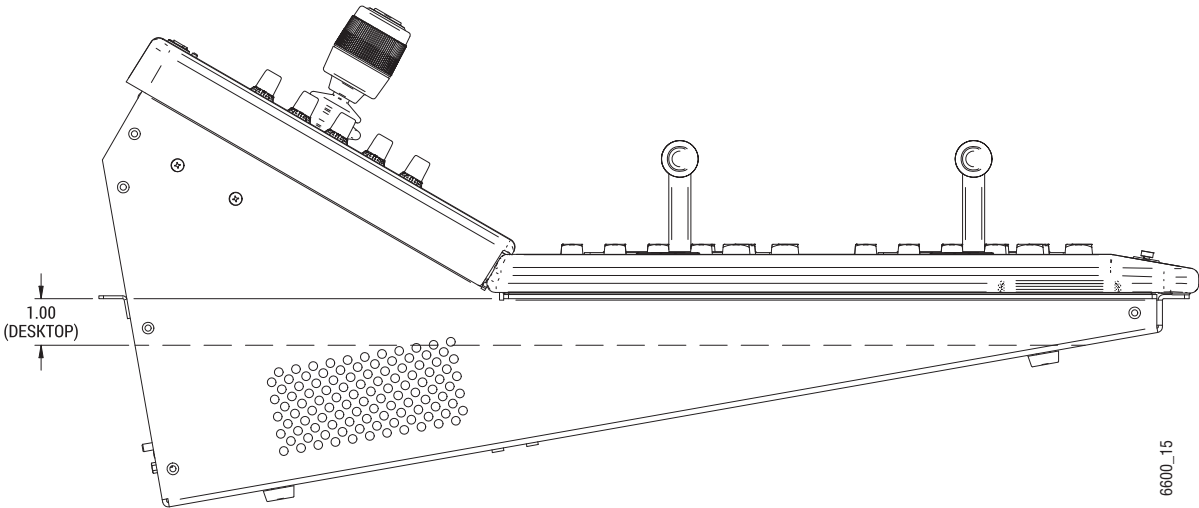

2-ME GV Korona Control Panel Left Side Mount to Vent Dimensions

## 2-ME GV Korona Control Panel Cutout Dimensions

**IMPORTANT:** All dimensions are in inches with millimeters in parenthesis.

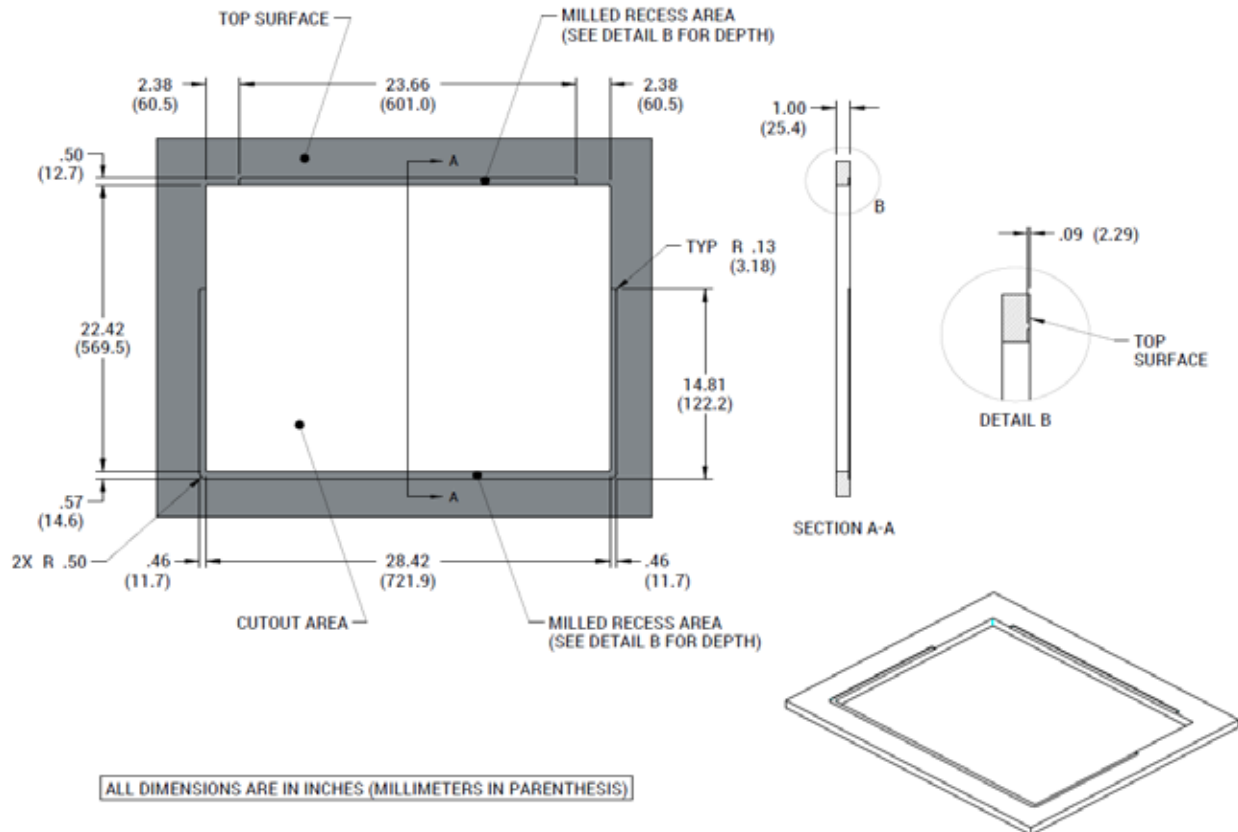

2-ME GV Korona Control Panel Cutout Dimensions

## 1-ME GV Korona Control Panel Dimensions

**IMPORTANT:** All dimensions are in inches with millimeters in parenthesis.

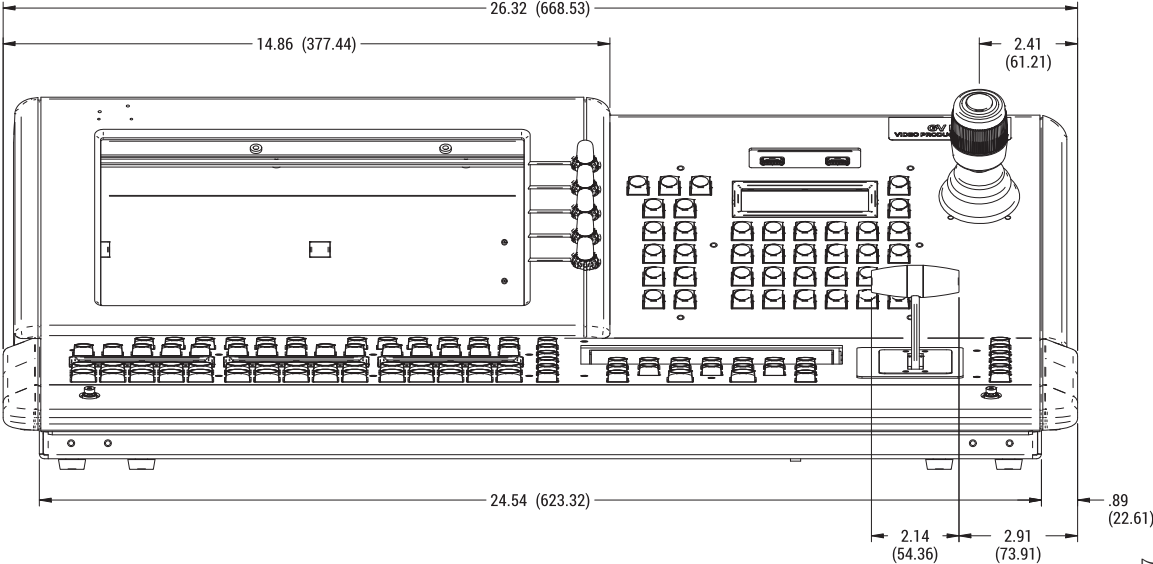

6600\_17

1-ME GV Korona Control Panel Front Dimensions

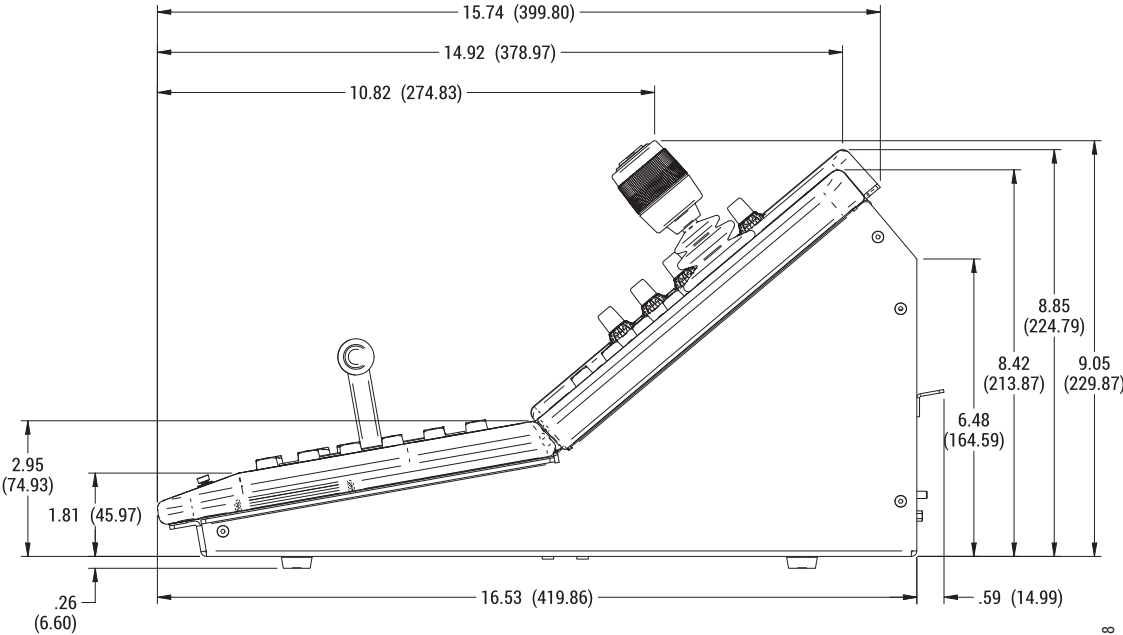

6600\_18

1-ME GV Korona Control Panel Side Dimensions

Control Surface Installation  
 1-ME GV Korona Control Panel Dimensions

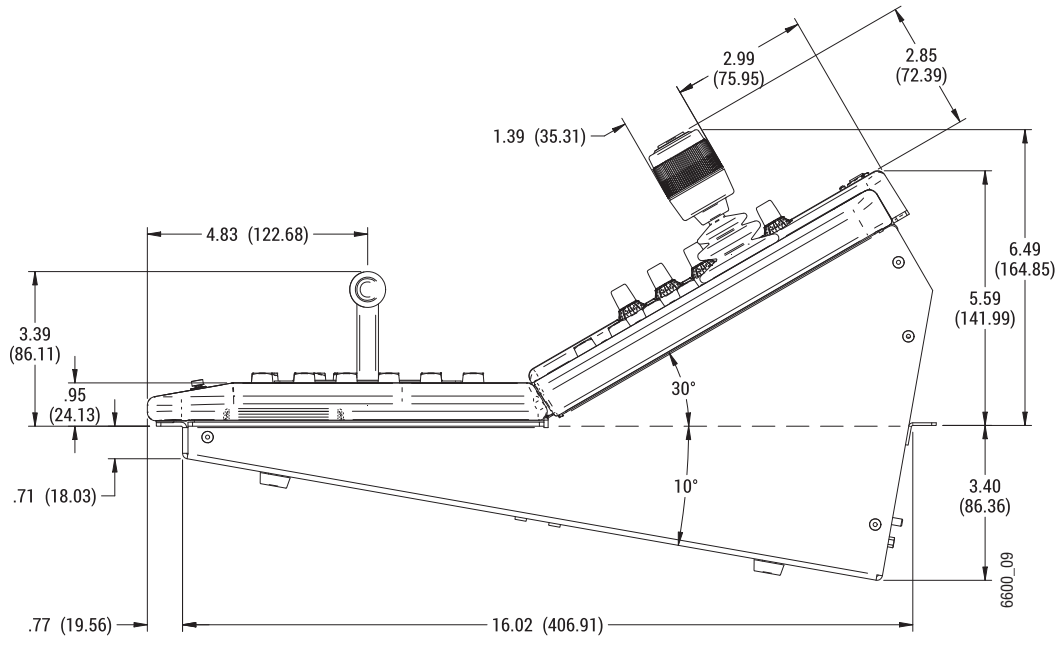

1-ME GV Korona Control Panel Mounting Dimensions

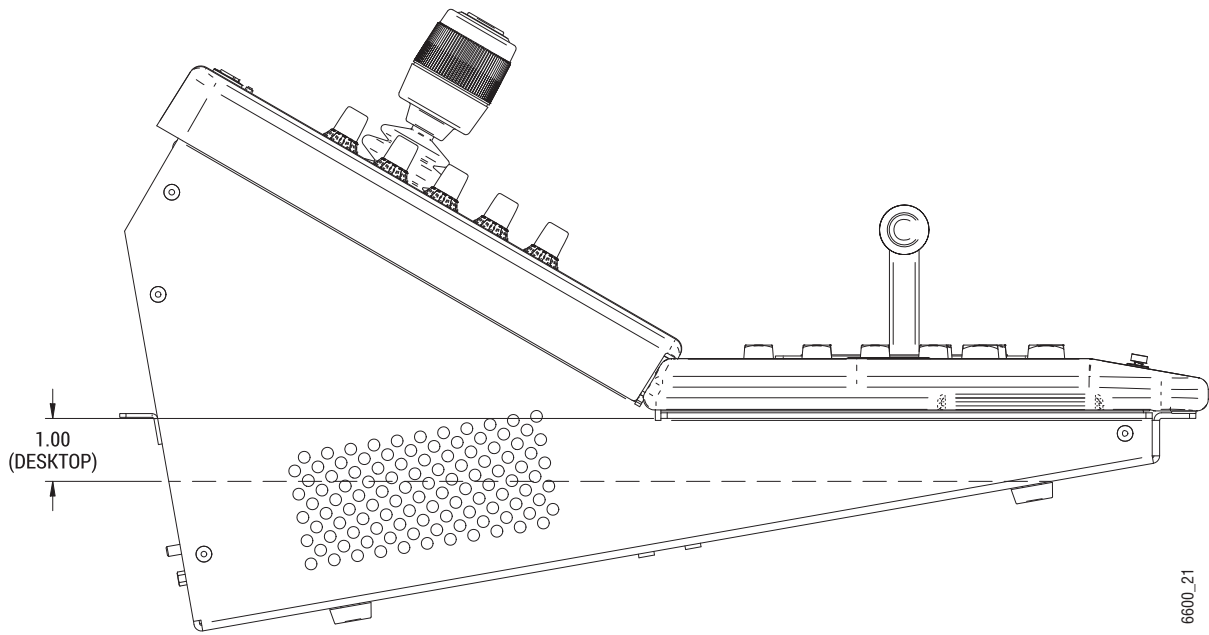

1-ME GV Korona Control Panel Left Side Mount to Vent Dimension

6600\_21

## 1-ME GV Korona Control Panel Cutout Dimensions

**IMPORTANT:** All dimensions are in inches with millimeters in parenthesis.

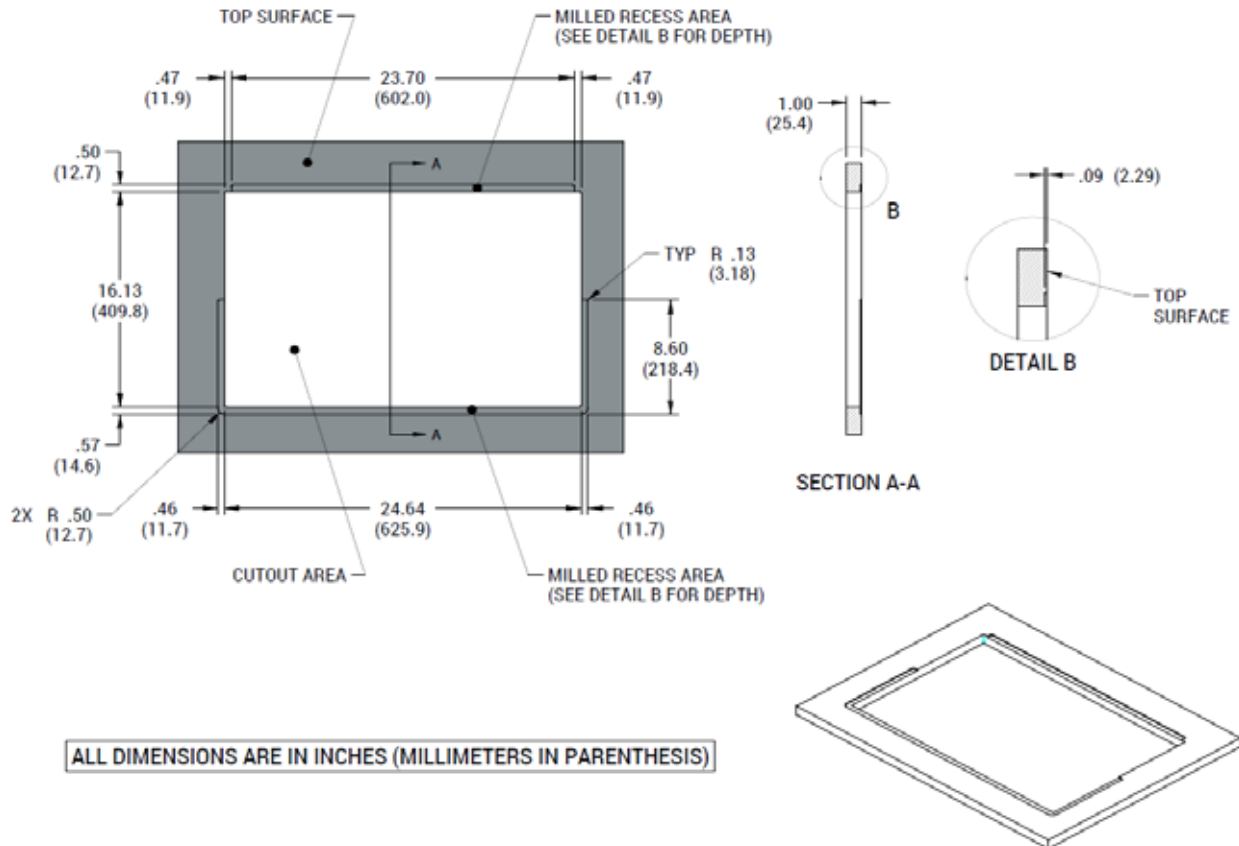



# 3 Frame Installation

## Overview

### Weight Distribution

Make sure that you mount the unit in the rack so that it is evenly balanced to prevent damage to the frame and to avoid creating a hazardous condition. K-Frame Video Processors require rear rack support.

### Cooling Requirements

The maximum ambient temperature for a Kayenne K-Frame chassis is 40-degrees C (104-degrees F) monitored at the air intake. Installing the frame in a closed or multi-unit rack assembly together with other units could increase the maximum ambient temperature for this unit.

Make sure you install the frame to allow for cooling airflow. When the unit is installed in a rack, ventilation openings should not be blocked or otherwise covered. Air intake holes exist on the right side of the K-Frame Video Processor (as you face the frame front) and air exhaust holes are on the left.

### Power Connections

When connecting the unit to the supply circuit be sure that the supply circuit of the rack is not overloaded. The unit must be well-grounded. The safety ground is accomplished via the third wire in the AC line cord(s). The rear panel ground lug is available for an optional ground.

All K-Frame Video Processor power supplies are 100V-240V AC +/-10% autorange, power factor corrected. Each power supply has its own line IEC line cord. Connecting each line cord to a separate AC circuit is recommended.

## 13-RU Video Processor Dimensions

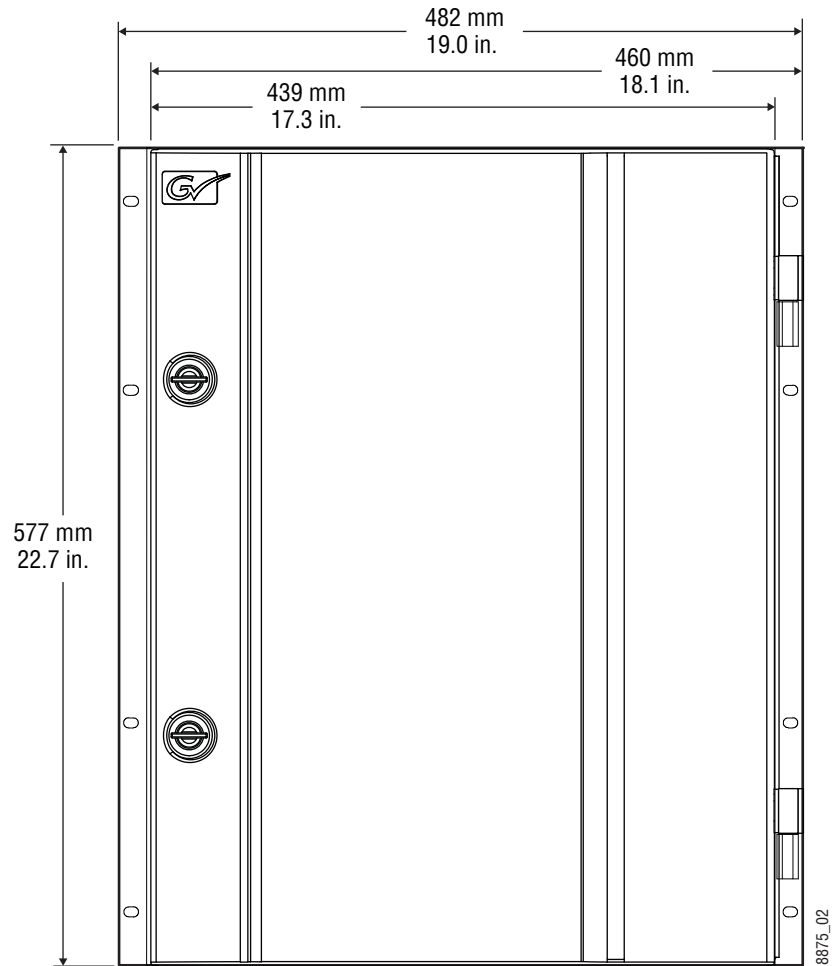

*K-Frame 13-RU Dimensions (Front View)*

**CAUTION:** Mounting a K-Frame in a rack immediately below equipment that extends forward from the rack may not provide enough clearance to completely remove the K-Frame door.



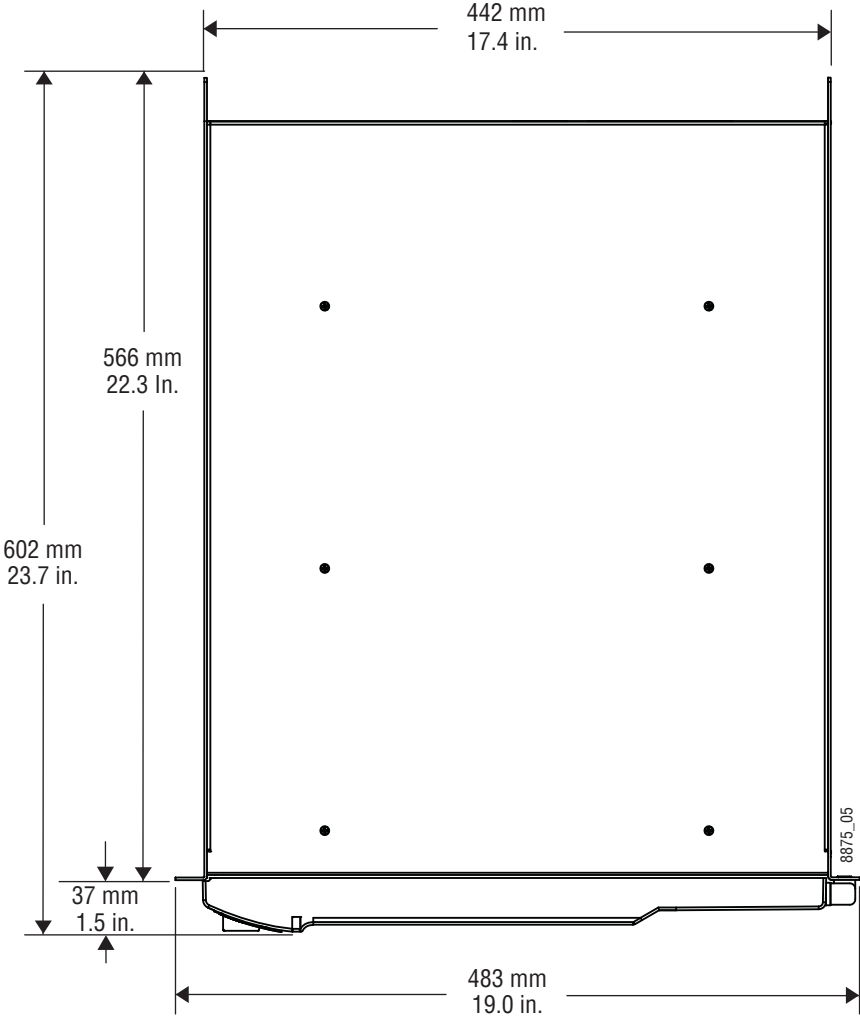

*K-Frame 13-RU Dimensions (Top View)*

## 13RU Video Processor Installation and Airflow

CAUTION: K-Frame installations require the use of the provided rear rack supports.

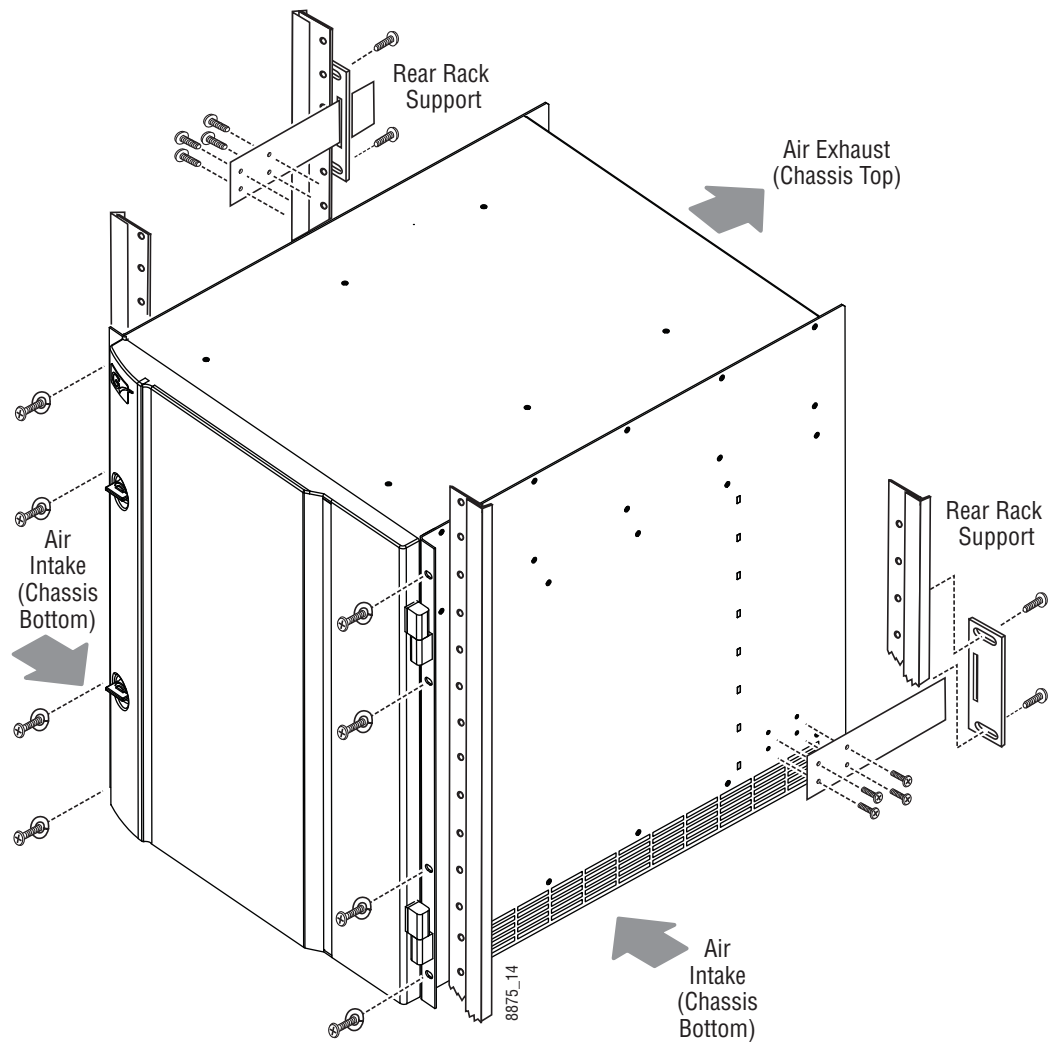

*K-Frame 13-RU Rack Mounting and Cooling Airflow*

## 13RU Video Processor Views

CAUTION: The Video Processor front door must remain in place and closed during normal system operation to maintain maximum cooling efficiency.

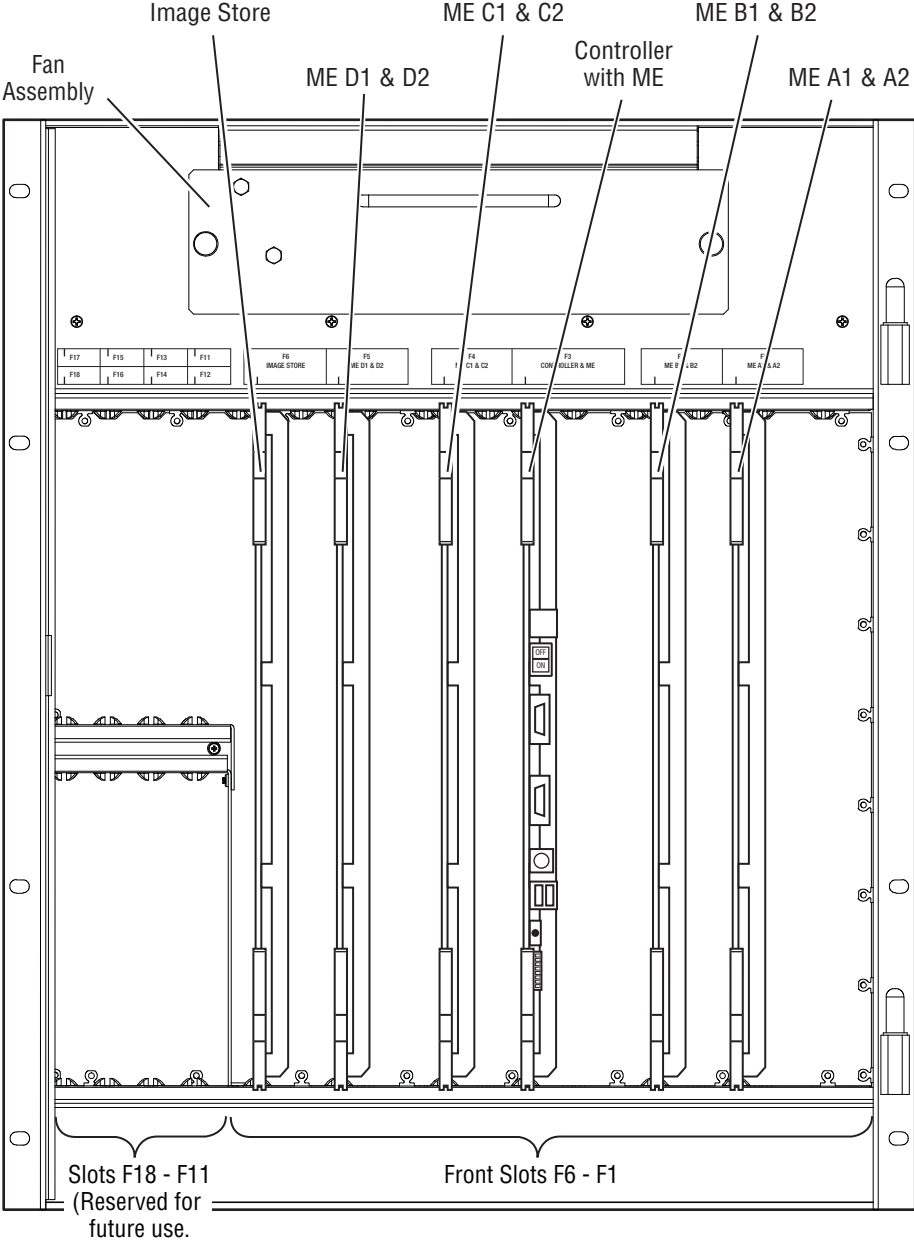

K-Frame 13-RU, Front View with Door Removed

Frame Installation  
13RU Video Processor Views

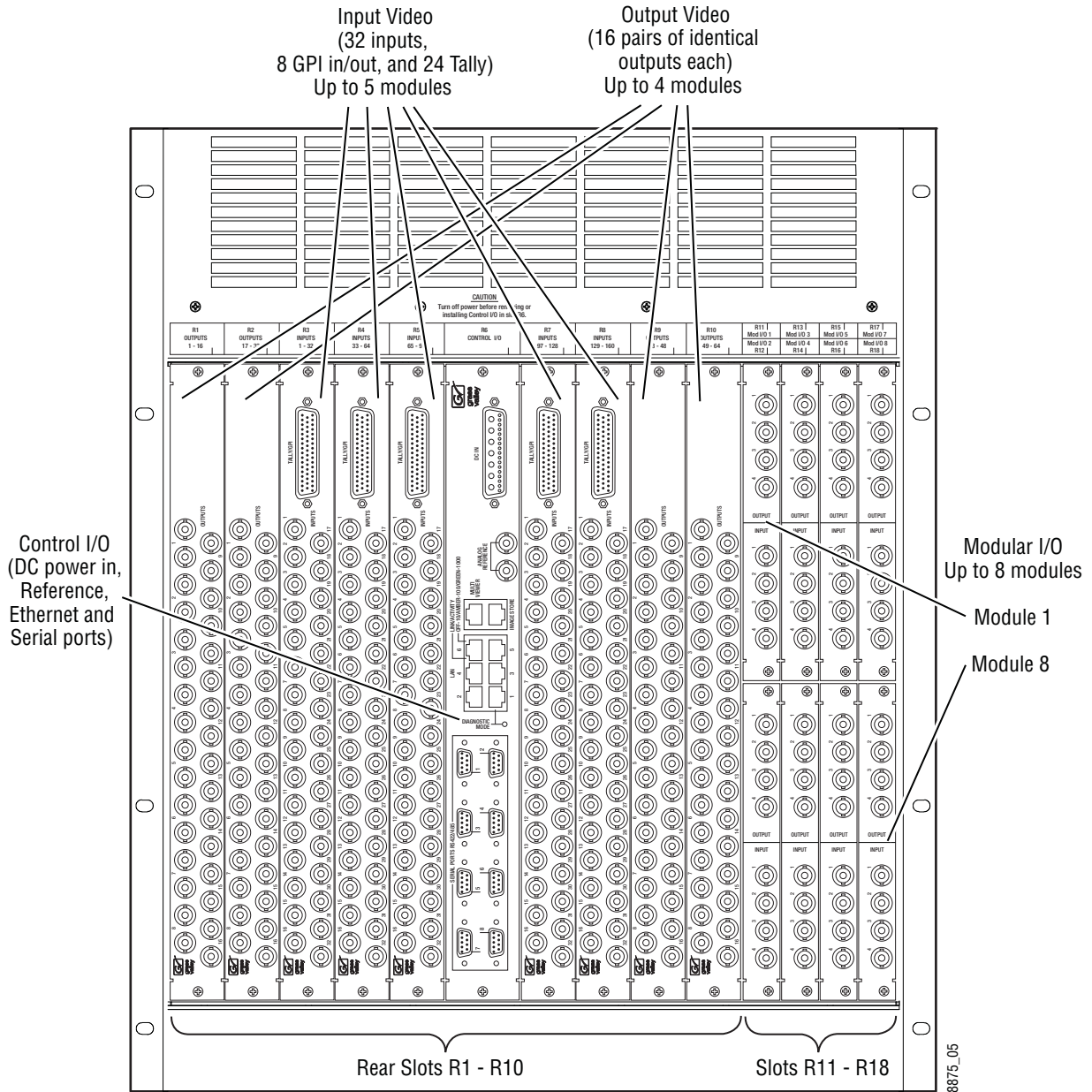

K-Frame 13-RU, Rear View

## 6-RU Video Processor Dimensions

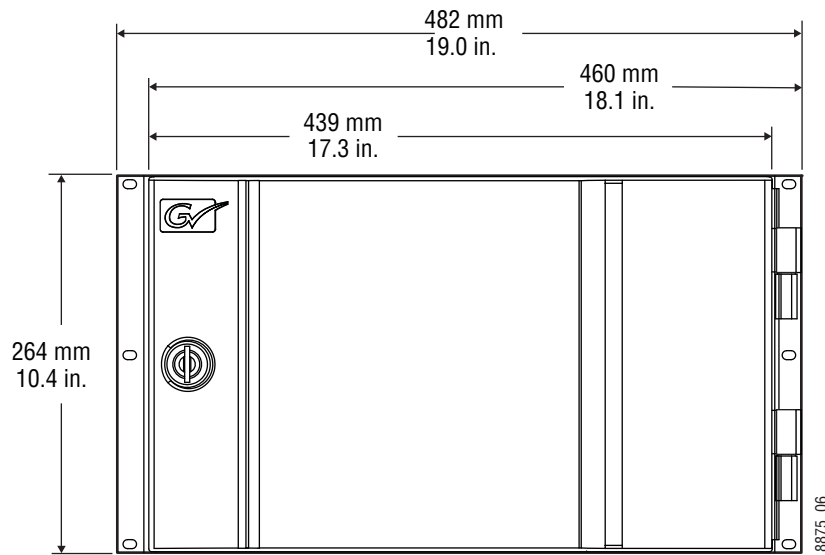

*K-Frame 6-RU Dimensions (Front View)*

**CAUTION:** Mounting a K-Frame in a rack immediately below equipment that extends forward from the rack may not provide enough clearance to completely remove the K-Frame door.

Frame Installation  
6-RU Video Processor Dimensions

---

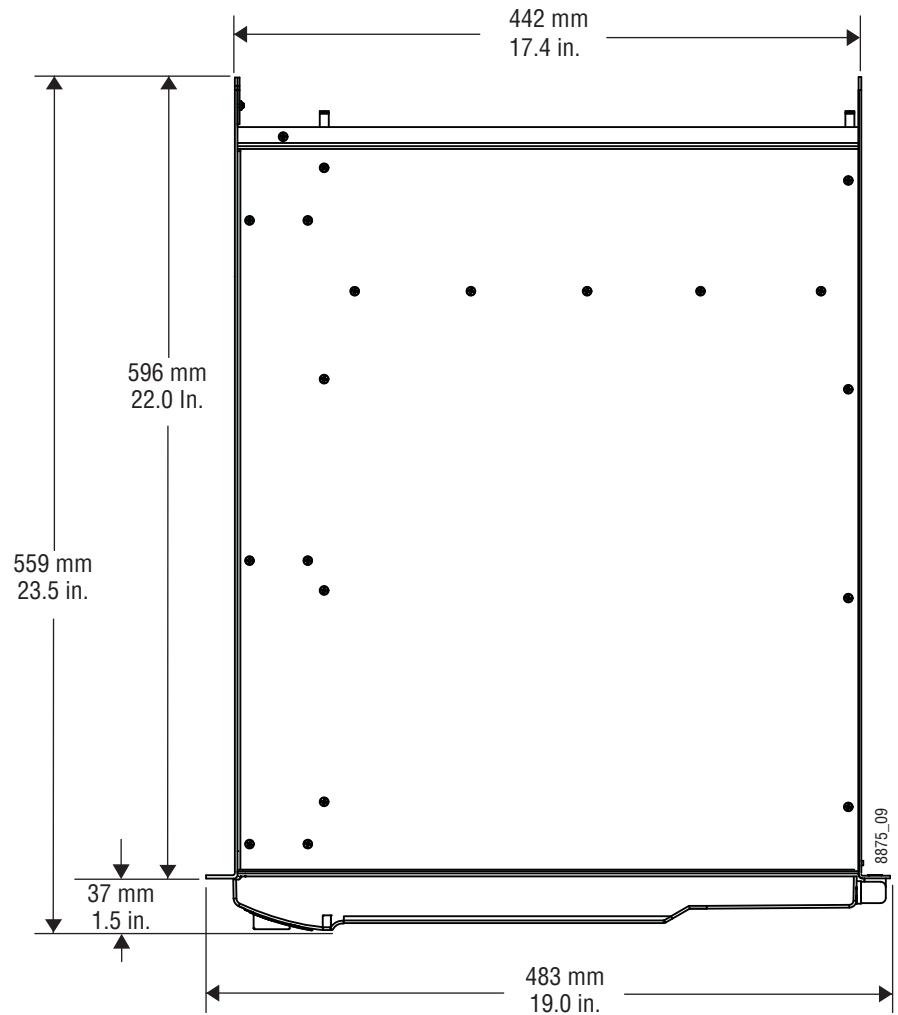

*K-Frame 6-RU Dimensions (Top View)*

## 6RU Video Processor Installation and Airflow

**CAUTION:** K-Frame installations require the use of the provided rear rack supports.

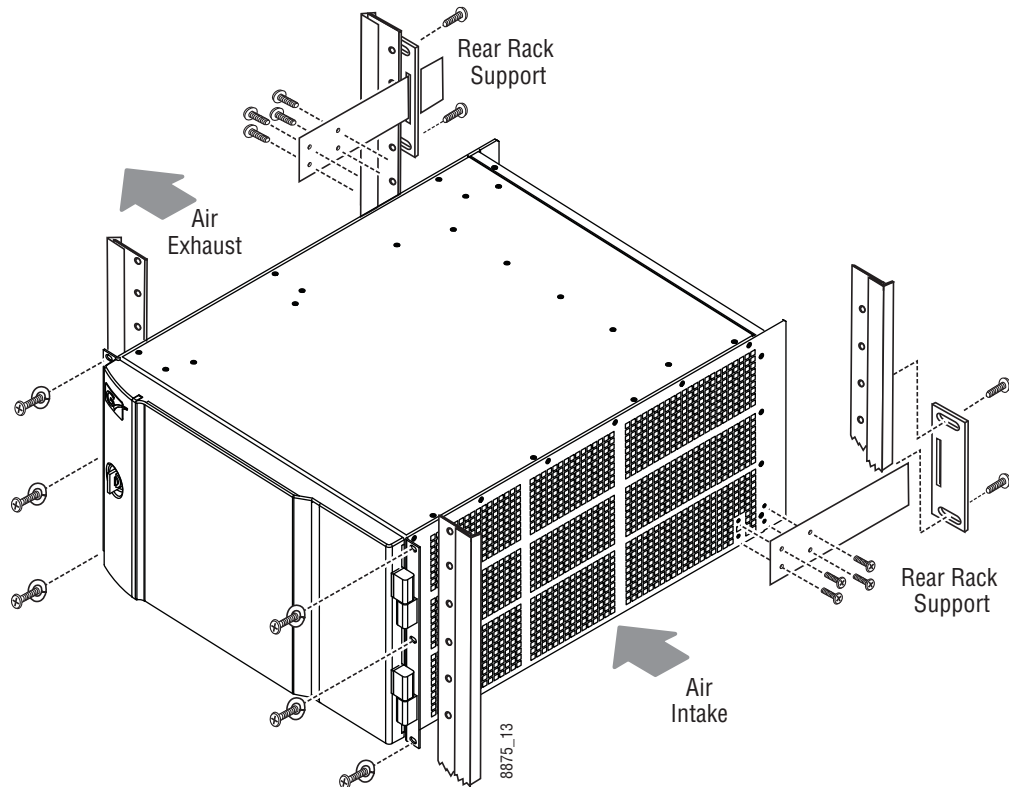

*K-Frame 6-RU Rack Installation and Cooling Airflow*

## 6RU Compact S-series Front View with Doors Removed

The Compact S-series Frame includes four keyers per ME and two Multiviewers on the Controller board.

**CAUTION:** The Video Processor front door must remain in place and closed during normal system operation to maintain maximum cooling efficiency.

Frame Installation  
6RU Compact Front Views with Doors Removed

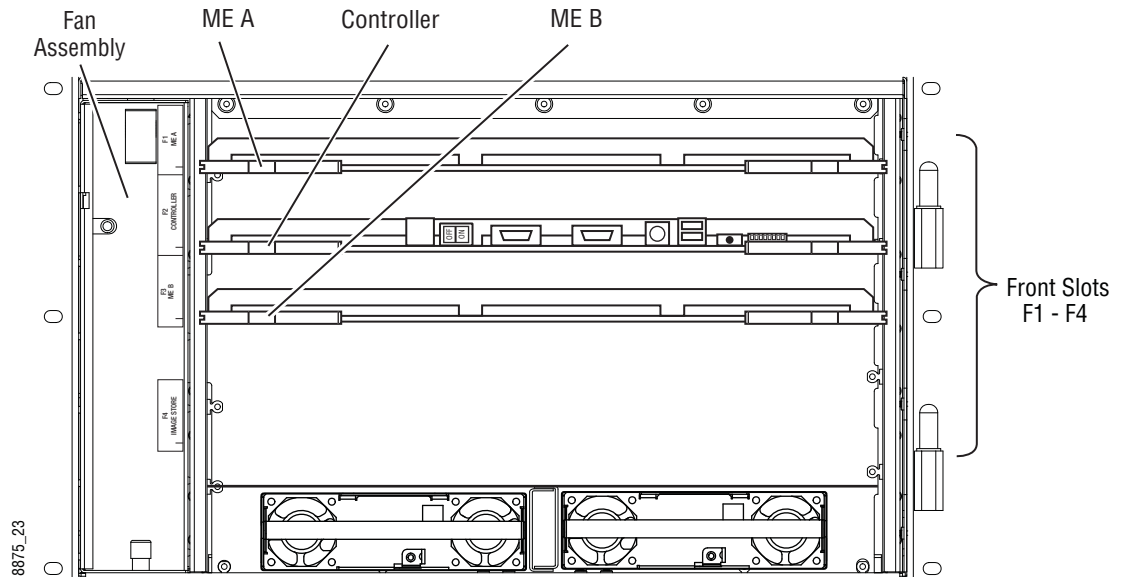

*K-Frame Compact S-series 6-RU, Front View with Door Removed*

## 6RU Compact Front Views with Doors Removed

The Compact Frame includes optionally, an Image Store board and six keys per ME.

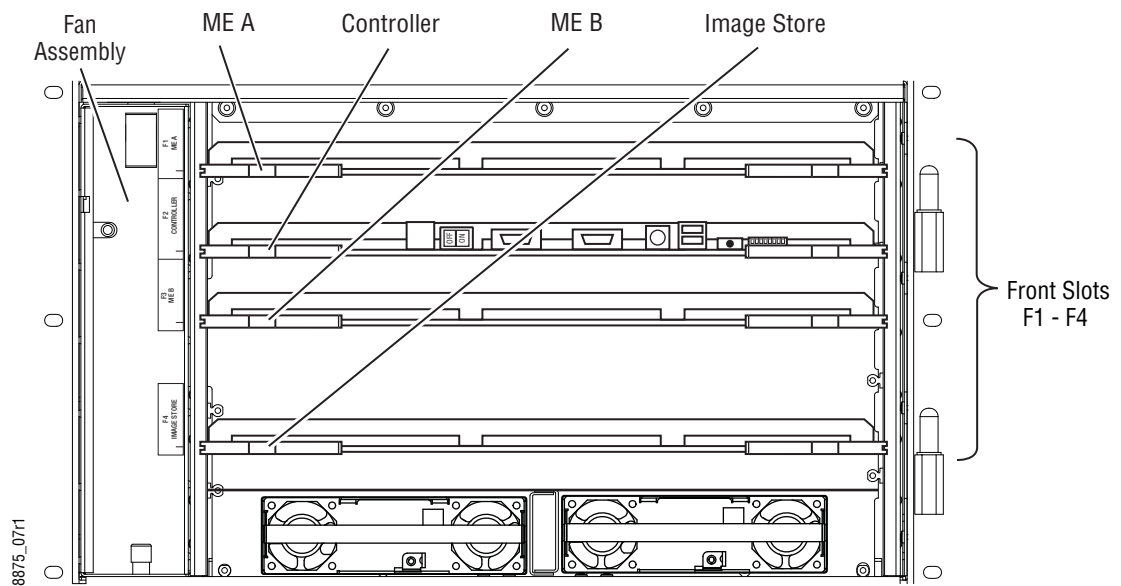

*K-Frame Compact Performance Frame 6-RU, Front View with Door Removed*



## 6RU Video Processor Rear View

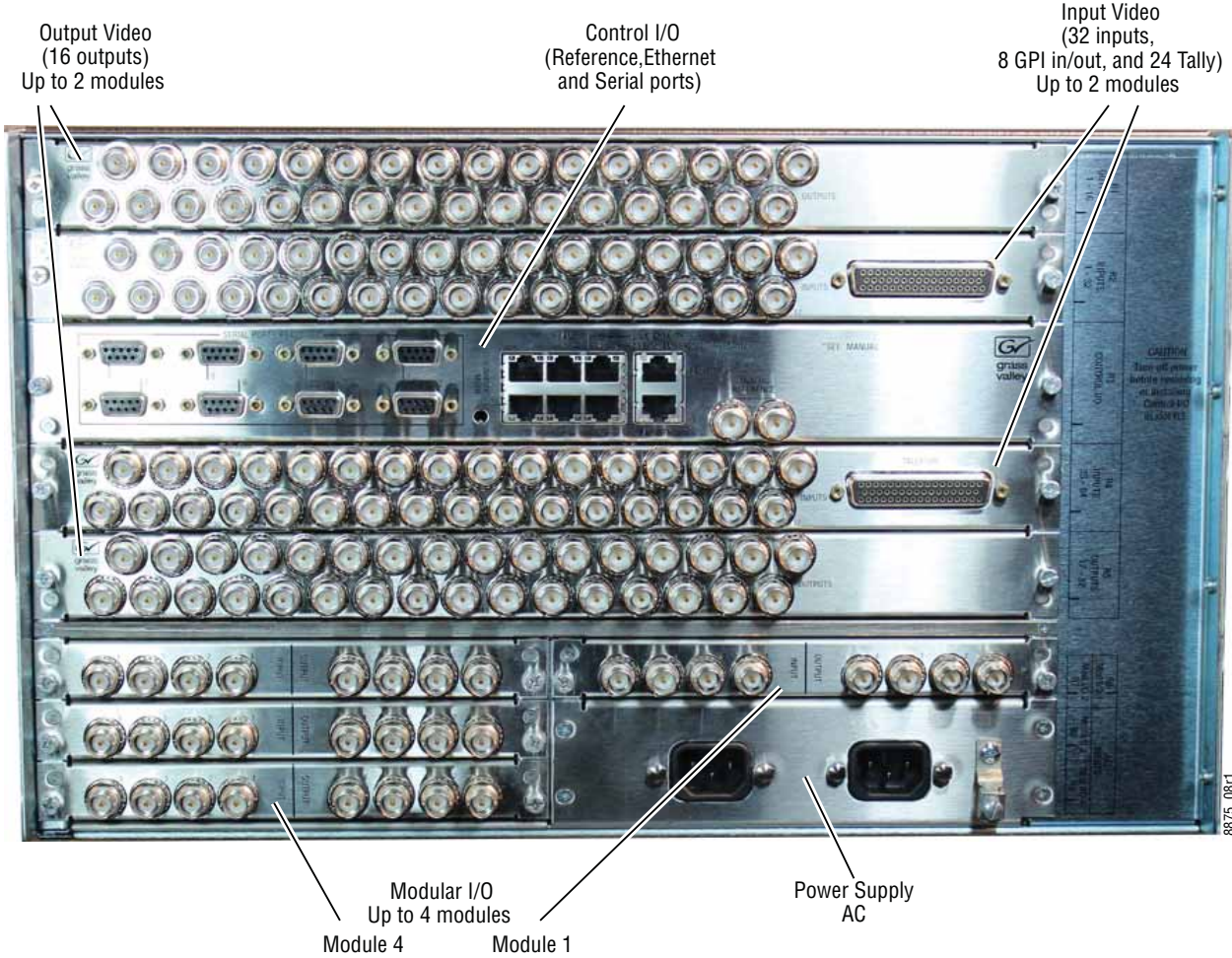

*K-Frame 6-RU, Rear View*

## K-Frame Controller Connections

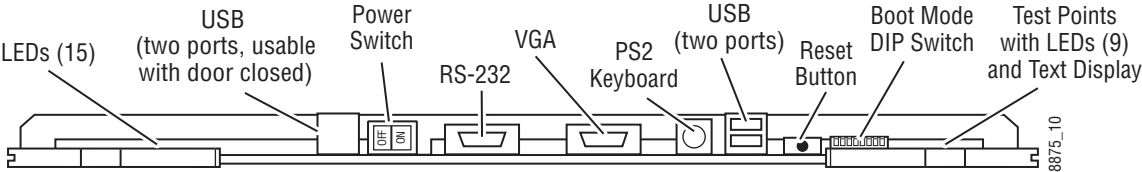

NOTE: Ports and indicators here are intended only for diagnostic and service procedures.

*K-Frame Controller Board, Inside Chassis*

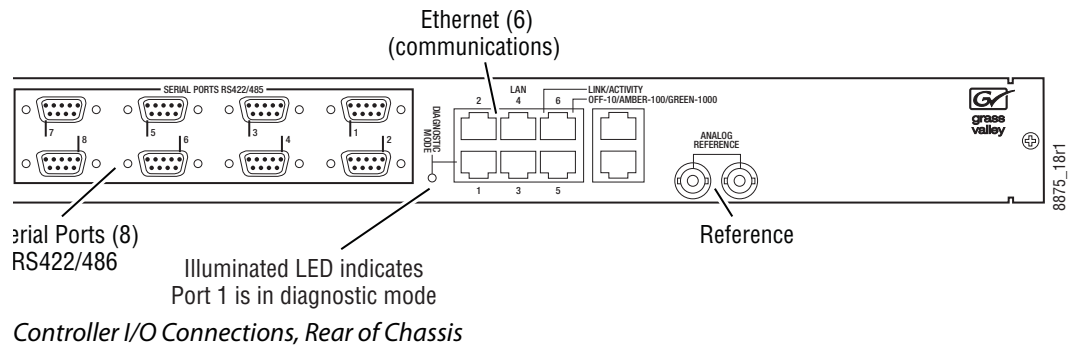

## K-Frame Standard Power Supply Views

A 1-RU Power Supply Frame provides DC power for the Standard, 13RU K-Frame Video Processor.

Front View with Cover

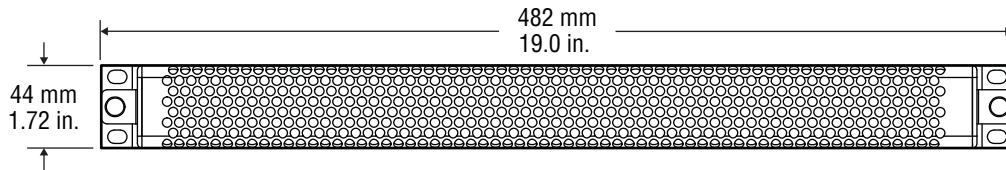

Front View Cover Removed

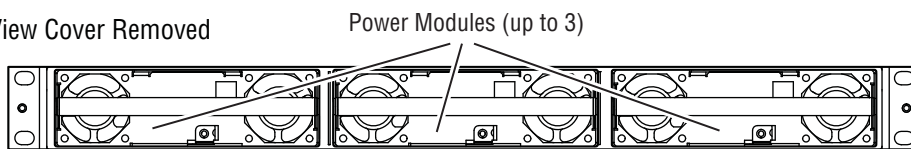

Rear View

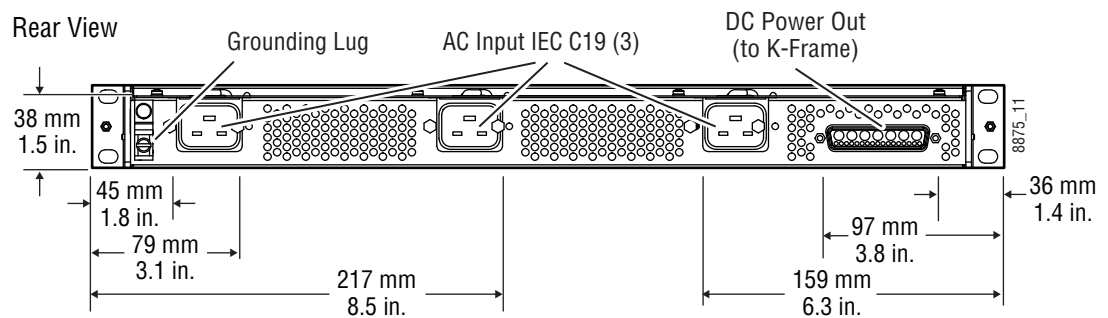

K-Frame 13RU Power Supply Frame Dimensions (Front and Rear Views)

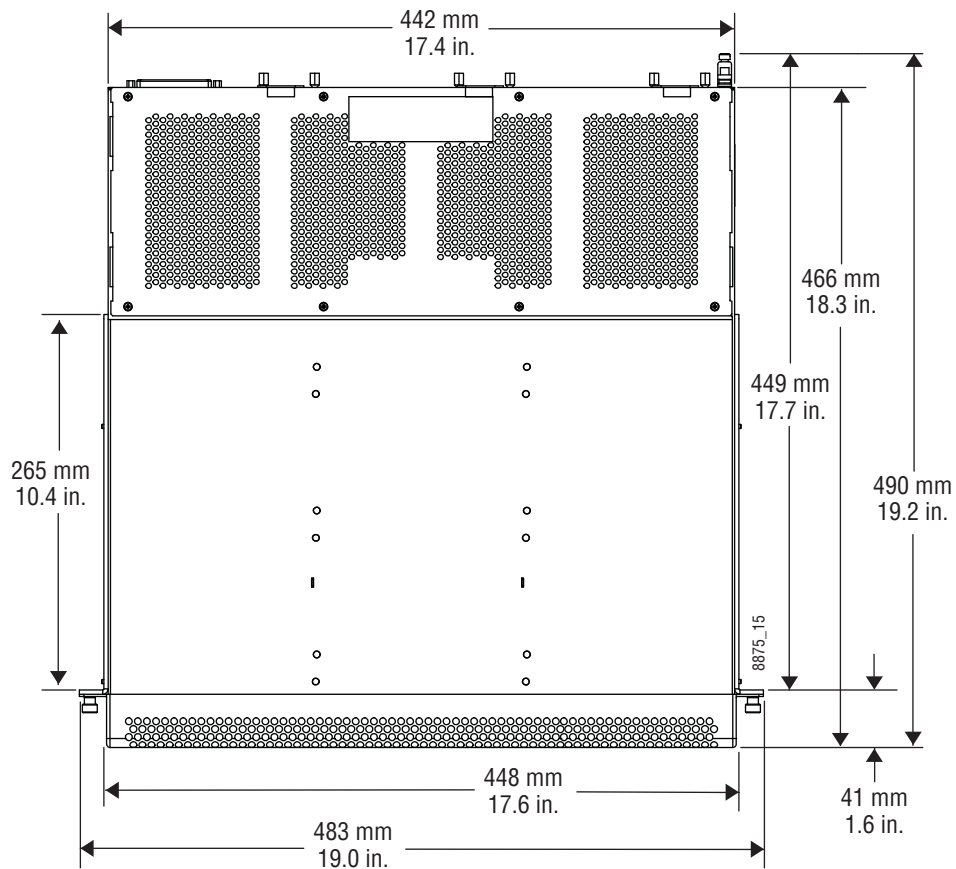

*K-Frame 13RU Power Supply Frame Dimensions (Top View)*

## K-Frame Standard Power Supply Frame Rack Installation and Airflow

The K-Frame power supply frame is ideally rack mounted immediately above the Standard Video Processor chassis. The power supply frame is then supported by the lower chassis and eliminates the need for power supply rear rack supports.

In addition, this placement allows removal of the front door of the K-Frame.

If the power supply frame is not mounted above the K-Frame chassis, rear rack supports are required. If mounting in an alternative location, allow for the 34" DC interconnect cable length.

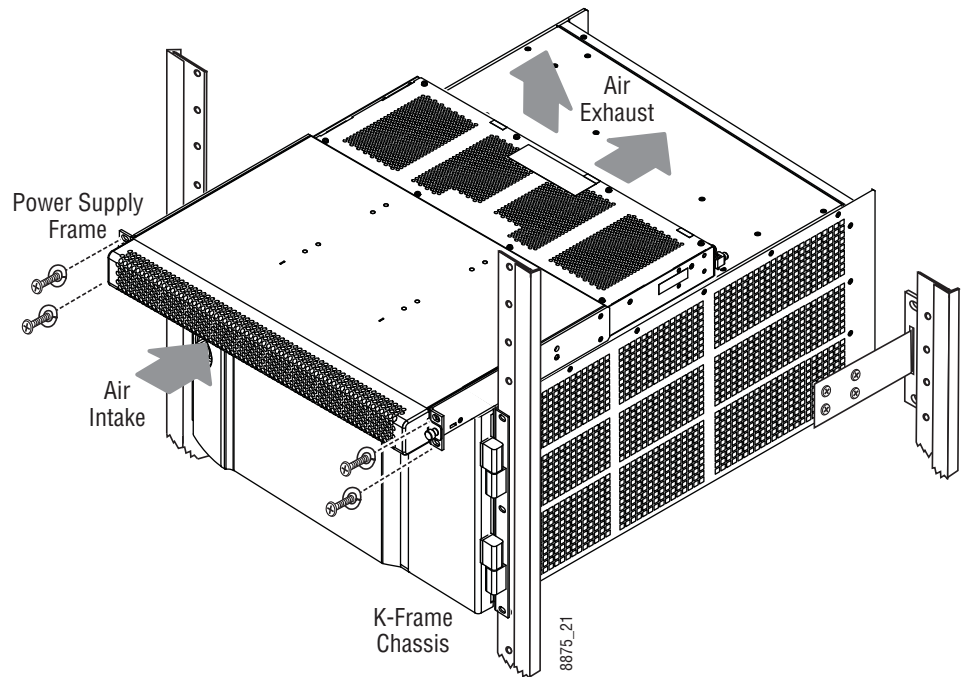

*Standard K-Frame Power Supply Rack Installation and Cooling Airflow*

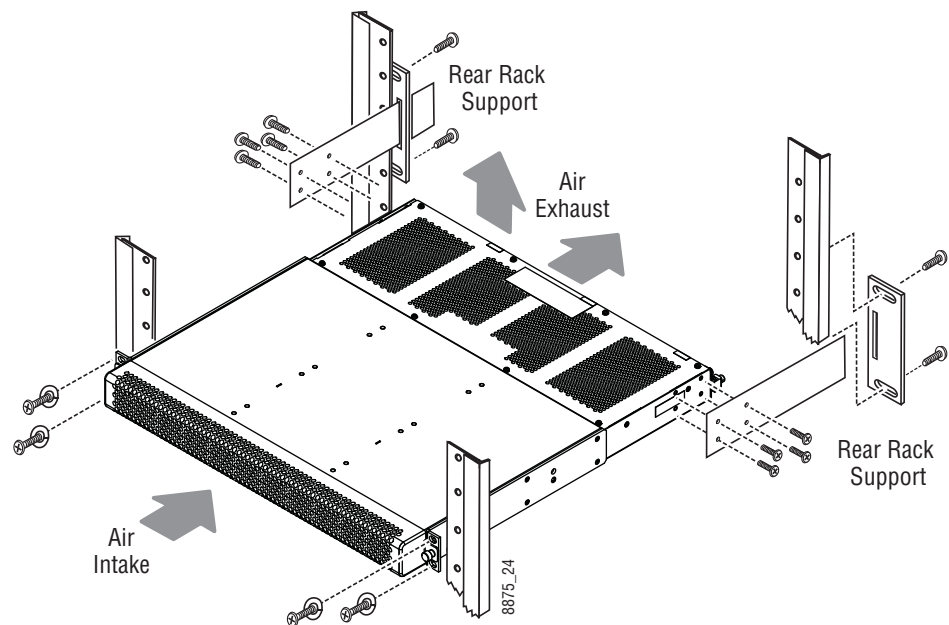

*Isolated K-Frame Standard Power Supply Rack Installation*

## **K-Frame Standard Power Supply Cooling**

The top surface of the rear of the K-Frame Power Supply Frame has air holes and is slightly recessed, which permits air flow even if equipment is mounted in the rack directly above.

These top recessed air holes must remain open for proper cooling. Ensure paper or other obstructions do not block these air holes.

## K-Frame Standard Power Supply AC Requirements

The K-Frame Power Supply Frame has provision to support up to three hot swappable power modules. These convert the AC line input to 48V DC for the Video Processor Frame. The cells for the three modules (referred to as left, center, right) are identical and any or all cells can have a module installed. Each cell has its own AC line cord. The supplies are power factor corrected and automatically accommodate low line (120V nominal) or high line (240V nominal). The power supply frame has a rating of 100 – 240 volts, although it is designed and tested for a range of 90 to 264 volts to accommodate under and over voltage conditions. A Compact K-Frame is supplied with one power module. A second power module can be fitted as a redundant power supply option. A Standard K-Frame is supplied with two power modules. A third power module can be fitted as a redundant (n+1) power supply option.

### Supplied Power Cables for Standard K-Frame

The K-Frame Power Supply Frame has IEC C19 sockets, instead of the more common C13 style, to accommodate potentially higher currents. Cables provided with K-Frame systems are matched to the destination country's standard. For example, in the USA C19 to NEMA 5-20P cables are provided.

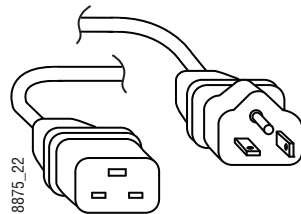

USA Power Cable Example

### About Low Line (120V) Operational Considerations

If low line (120V) operation is used (mostly in North America) three characteristics of the switcher should be kept in mind when provisioning AC power for the system, which will result in the most reliable system possible:

- Consider brown-out—Modern switching power supplies are constant power devices and as such, unlike resistive loads, the input current increases as the input voltage decreases.
- Consider power supply failure—If two or three power modules are present, they will load share. For instance, if two modules are fitted and the total AC line current is 10 amps, each of the two line cords will draw about 5 amps. If one supply fails, the other supply takes up the entire load. At this point, one line cord will draw 0 amps and the other cord will draw 10 amps.

- Consider future options—The total AC power consumption is significantly influenced by the number and type of hardware options installed. This includes the number of MEs, Inputs, Outputs, and Modular I/Os.

## About High Line (208V-240V) Verses Low Line (120V) Operations

North American users usually have a choice to use low line (120 volts) or high line (208-240 volts) as the AC source. If Lo line is used, a Standard (13RU) K-Frame with all options installed and running at 120 volts will draw a total of approximately 12 amps from the line cords. At 100 volts, this increases to approximately 14 amps. This load will be evenly distributed among the line cords. However, if one or more power supplies go offline, it is possible for the entire 12 – 14 amps to be drawn by one line cord. For this reason, it is recommended that each line cord be serviced by a dedicated 20 amp circuit. If this circuit is shared by other loads, consider what will happen if the switcher line cord suddenly doubles (or triples) its current consumption.

One 20 amp circuit is adequate to service the two or three K-Frame line cords since the total current never exceeds 14 amps. The only disadvantage is the reduced redundancy using one branch circuit instead of multiple circuits. In a three phase WYE distribution system, additional protection can be achieved by using different phases for each of these circuits.

The possibility of drawing as much as 14 amps from a line cord explains the 20 amp (NEMA 5-20P) plug on the line cords supplied. The NEC in the US specifies that the ubiquitous 15 amp outlet be de-rated to 12 amps for continuous loads. A 20 amp outlet is needed for the rare case of a 14 amp load experienced during a fault condition.

Most of the above is not an issue if high line (240V) operation is used. Since AC line currents are approximately half of those at low line, exceeding the current rating of a circuit should not be a problem. In areas where there is a choice between high line or low line operation, the user should consider the advantages and disadvantages of each power sourcing scheme.

## K-Frame Compact Power Supply AC Requirements

The K-Frame chassis has provision to support up to two hot swappable power modules. These convert the AC line input to 48V DC for the Video Processor Frame. The cells for the two modules (referred to as left and right) are identical and either or both cells can have a module installed. Each cell has its own AC line cord. The supplies are power factor corrected and automatically accommodate low line (120V nominal) or high line (240V nominal). The power supplies have a rating of 100 – 240 volts, although it is designed and tested for a range of 90 to 264 volts to accommodate under and over voltage conditions. A Compact K-Frame is supplied with one power module. A second power module can be fitted as a redundant power supply option.

## About Low Line (120V) Operational Considerations

If low line (120V) operation is used (mostly in North America) three characteristics of the switcher should be kept in mind when provisioning AC power for the system, which will result in the most reliable system possible:



- Consider brown-out—Modern switching power supplies are constant power devices and as such, unlike resistive loads, the input current increases as the input voltage decreases.
- Consider power supply failure—If two or three power modules are present, they will load share. For instance, if two modules are fitted and the total AC line current is 10 amps, each of the two line cords will draw about 5 amps. If one supply fails, the other supply takes up the entire load. At this point, one line cord will draw 0 amps and the other cord will draw 10 amps.
- Consider future options—The total AC power consumption is significantly influenced by the number and type of hardware options installed. This includes the number of MEs, Inputs, Outputs, and Modular I/Os.

## About High Line (208V-240V) Verses Low Line (120V) Operations

North American users usually have a choice to use low line (120 volts) or high line (208-240 volts) as the AC source. If Lo line is used, a Compact K-Frame with all options installed and running at 120 volts will draw a total of approximately 9 amps from the line cords. At 100 volts, this increases to approximately 10 amps. This load will be evenly distributed among the line cords. However, if one or more power supplies go offline, it is possible for the entire 10 amps to be drawn by one line cord. For this reason, it is recommended that each line cord be serviced by a dedicated 20 amp circuit. If this circuit is shared by other loads, consider what will happen if the switcher line cord suddenly doubles its current consumption.

One 20 amp circuit is adequate to service the two K-Frame line cords since the total current never exceeds 10 amps. The only disadvantage is the reduced redundancy using one branch circuit instead of multiple circuits.

Most of the above is not an issue if high line (240V) operation is used. Since AC line currents are approximately half of those at low line, exceeding the current rating of a circuit should not be a problem. In areas where there is a choice between high line or low line operation, the user should consider the advantages and disadvantages of each power sourcing scheme.

## Replacing Compact Power Supplies

Compact K-Frame Video Processors come with one power supply with the option of a second, located in the front of the chassis. Power supplies are hot swappable in systems containing two power supplies.

**CAUTION:** ESD equipment and procedures should be used when servicing electronic components.

- 1 Remove the power supply.
  - a Open the front door of the Compact K-Frame.
  - b Locate the lock and lock screw, located in the front, lower middle of the power supply labeled OPEN and LOCKED.

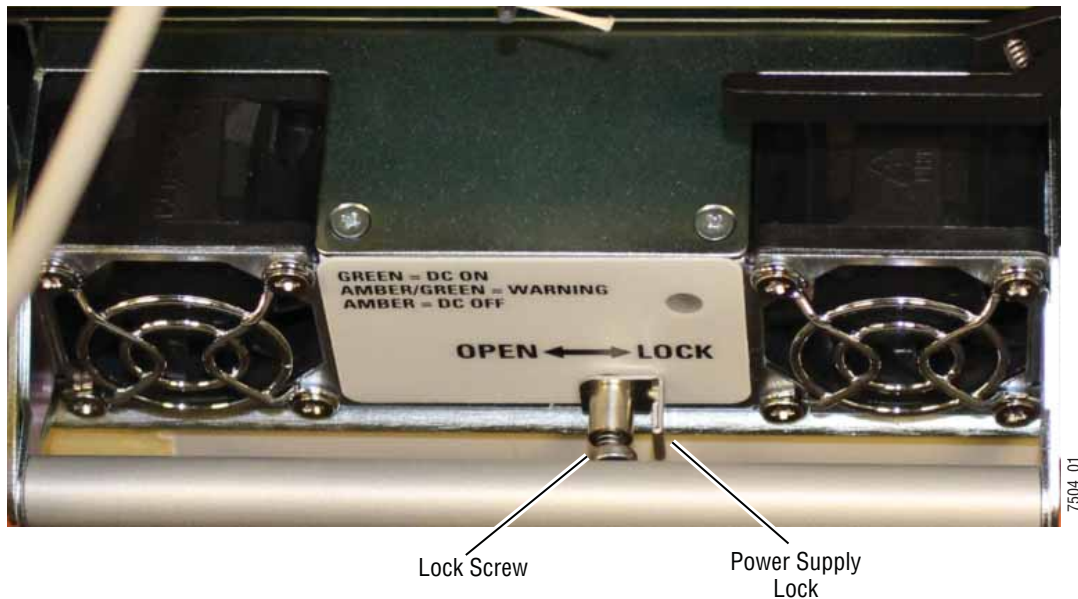

*Compact Frame Power Supply Lock Screw*

- c Loosen the lock screw a few turns to the left, using a Phillips head screwdriver.
  - d Slide the lock toward the OPEN label (left) and pull the power supply straight out of the chassis.
- 2 Replace the power supply.
- a Slide the replacement power supply straight in and make sure the lock is in the LOCKED position.
  - b Tighten the lock screw to the right, just until tight.
  - c Close the Compact K-Frame door, making sure that it latches in the closed position.

## K-Frame Video Processor Door Removal Clearance

**CAUTION:** The Video Processor front door must remain in place and closed during normal system operation to maintain maximum cooling efficiency.

The K-Frame Video Processor door on all K-Frames can be completely removed when installed in a rack immediately below conventional flush mounted rack-ear only equipment. If the Standard K-Frame power supply Frame is mounted directly above the Standard K-Frame chassis, the chassis door can be completely removed after removing the power supply's front screen. However, mounting any K-Frame (including Compact Performance and Compact S-series) in a rack immediately below other equipment that extends forward from the rack (for example, under another K-Frame chassis) may not provide enough clearance to remove the K-Frame door.

If mounted below equipment that extends forward from the rack, allow at least 24 mm (0.94 in.) of vertical clearance above the K-Frame to permit door removal. A flush design 1 RU blank filler panel can be used for clearance, if required.



# 4 System Cabling

## About the K-Frame System Cabling Section

This section provides overview information that is common to all K-Frame systems as well as information specific to Kayenne, Karrera, and GV Korona K-Frame Control Panels and components.

## K-Frame System Cabling Overview

The K-Frame systems use Ethernet, serial, and USB connections and custom multi-pin cables for Kayenne. The K-Frame Video Processors have built-in Ethernet switches. Each Video Processor has Tally outputs and GPI I/O (General Purpose Interface Input/Output) control available.

## K-Frame Ethernet Tally Verses Serial Tally

Our K-Frame tally system provides significantly more information than the bandwidth of the serial connection. Therefore, we support Ethernet tally only. However, many tally vendors do support our Ethernet tally system so contact your tally vendor for K-Frame Ethernet tally support information.

## Suites and Control Surfaces

A K-Frame system can be divided into two suites. K-Frame Video Processor resources (MEs, eDPMs, external devices, etc.) can be assigned to each suite, creating two switchers with one K-Frame. Each suite can be subdivided into two control surfaces, using Kayenne, Karrera, GV Korona Control Panels and Soft Panels and Menu on PC. Each control surface is intended for use by a single operator. The K-Frame Control Panel system flexibility permits locating these control surfaces in physically separate locations.

## Network Cabling

The Ethernet switches built into the K-Frame Video Processor and PCU (Kayenne only) auto-detect speed and polarity, and are 10/100/1000 Mbps capable. Either straight-through or crossover Ethernet cabling can be used. Available Ethernet connectors may be connected to the Facility LAN or other devices, as needed. However, should the K-Frame Video Processor or PCU power down, the internal Ethernet switches will also power down, interrupting communication to devices connected to that K-Frame's or PCU's internal Ethernet switches. Only connect devices that are K-Frame system related.

## K-Frame Ethernet Switch

The Ethernet switch built into the K-Frame auto-detects speed and polarity, and is 10/100/1000 Mbps capable. Either straight-through or crossover Ethernet cabling can be used. Available Ethernet connectors may be connected to the Facility LAN or other devices, as needed. However, should the K-Frame power down, the internal Ethernet switch will also power down, interrupting communication to devices connected to that Frame's internal Ethernet switch. Only connect devices that are system related.

## Customer Supplied Ethernet Routers and Switches

Existing facility Ethernet switches can be used in conjunction with a Kayenne system. If connecting to a network area outside that used by the Kayenne system, use of an appropriately configured Ethernet Router is strongly advised. This reduces network traffic on the Kayenne network and keeps it isolated. Any Ethernet switches added specifically for use with the Kayenne system should be 1000 Mbps capable for the most efficient operation.

### Ethernet Specifications

<b>Cables</b>	<b>Type</b>	10BaseT, 100BaseT, 1000BaseT compatible Category 5 cable, 8 conductor twisted pair The system will work at lower ratings with reduced performance. 1000BaseT components are highly recommended.
	<b>Connectors</b>	RJ-45 male connector at each end of cable.
	<b>Length</b>	100BaseT, 1000BaseT: 328 ft. (100 m) maximum. 10BaseT: 984 ft. (300 m) maximum. Use additional switches to exceed maximum cable runs.
<b>Switch</b>	<b>Speed</b>	10/100/1000 Mbps
	<b>Ports</b>	RJ-45 auto-negotiating 10/100/1000 Mbps; number of ports required is dependent upon system size. Frame and PCU ports are capable of 1000 Mbps. Using a 1000 Mbps Ethernet switch enhances Image Store transfer speeds.
	<b>Unmanaged</b>	Recommended. Configuration not required, but does not provide remote monitoring capability.
	<b>Managed</b>	May be used. Requires configuration, but offers remote monitoring capability.

To integrate K-Frame devices into an existing network, ask the local network administrator for that network's subnet mask. Before changing IP addresses always set the subnet masks of the K-Frame devices to the mask of the local network.

## Factory Default Network Settings

### K-Frame System Default IP Addresses

Devices	IP Address
Video Processor Frame CPU	192.168.0.170
Image Store CPU	192.168.0.171
Control Panel Surface 1A	192.168.0.173
Touch Screen Menu Panel 1 (Kayenne/Karrera)	192.168.0.175
Touch Screen Menu Panel 2 (Kayenne/Karrera)	192.168.0.176
Control Panel Surface 1B	192.168.0.177
Control Panel Surface 2A	192.168.0.178
Control Panel Surface 2B	192.168.0.179
Clip Store	192.168.0.180
Kayenne/Karrera only: 32-Crosspoint Remote Aux Panels V1.6.5 and higher software: (hard reset with the front panel buttons)	IP Address: 192.168.1.2 Frame IP: 192.168.1.1 Gateway IP: 192.168.1.1 Subnet Mask 255.255.255.0  Note: 32-Crosspoint Remote Aux Panel default settings must be changed to operate with a Kayenne/Karrera system whose other components are configured with their default IP addresses.
All Subnet Masks)	255.255.255.0
All Gateways (except V1.6.5 software Remote Aux panel)	192.168.0.1
<b>Following Reserved For Future Use</b>	<b>CAUTION: Do not connect any devices configured with the following IP addresses to a Kayenne network.</b>
Video Processor Frame Gigabit Ethernet	192.168.0.172
PCU Panel Reserved LAN Port	192.168.0.174

**Note:** Customer orders with multiple Control Panels will be pre-configured to the listed IP addresses. However, if one of these additional Control Panels is reset to factory defaults, it will be given the standard 1A default 192.168.0.173 address.

To integrate K-Frame system devices into an existing network, ask the local network administrator for that network's subnet mask. Before changing IP addresses always set the subnet masks of the devices to the mask of the local network.

## Kayenne K-Frame System Cabling

USB, Ethernet, and custom multi-pin cabling is used to connect the Kayenne Video Processing Frame, Panel Control Unit (PCU), Control Panel, and Menu Panel components.

!!!!!!See INSERT X-REF HERE for information about multi-pin cable pin-outs.

In addition to the Video Processing Frame, the PCU also includes a built-in Ethernet Switch.

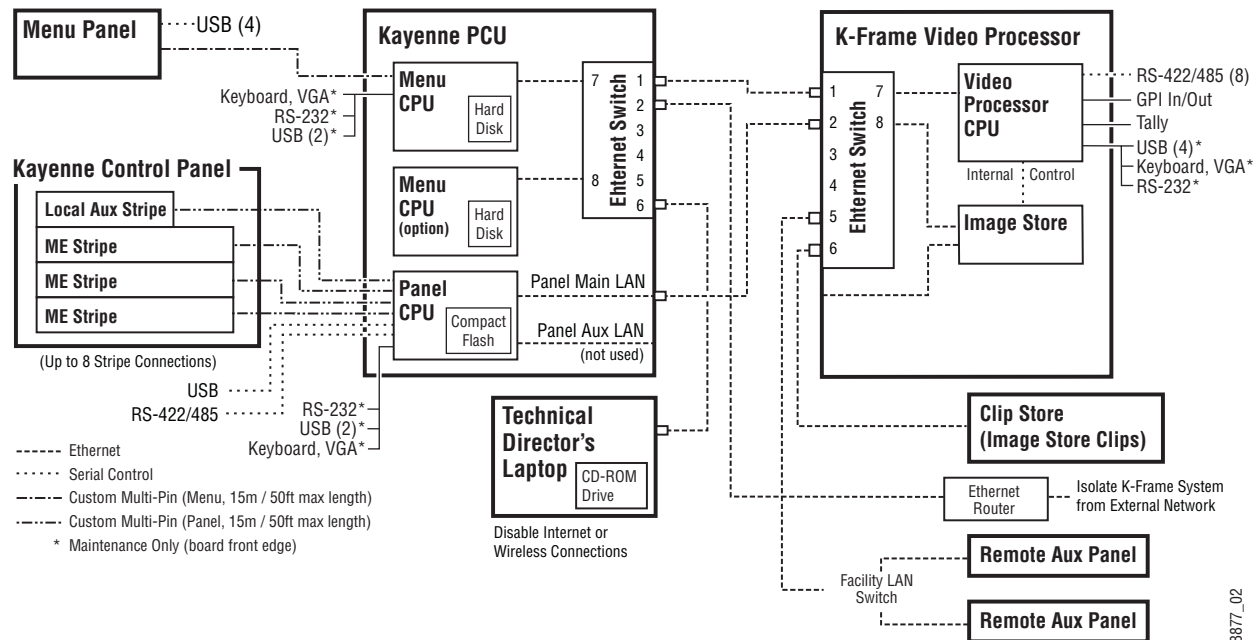

Kayenne K-Frame System Communications Overview

**CAUTION:** The facility network used for your K-Frame system (and other video production equipment) should be kept separate from any external network, to prevent network traffic from adversely affecting K-Frame system operation.

## Kayenne Network Cabling

Network connections are required between the K-Frame Video Processor and the PCU. The PCU routes network communications to and from the Control Panel Stripes and Menu Panels, using custom multi-pin cables.

The use of two Ethernet cables to connect the PCU to the K-Frame Video Processor is recommended.

Two Cable PCU Frame Connection

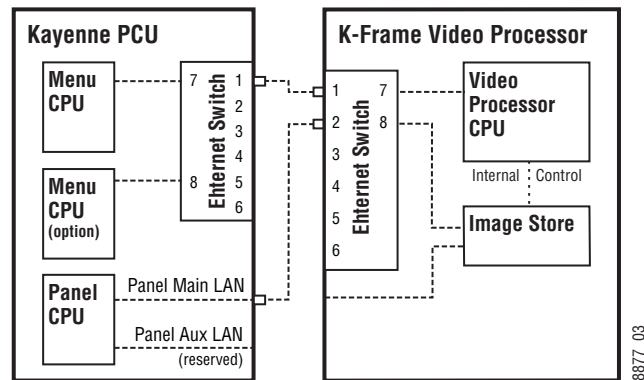

*PCU to Kayenne K-Frame Network Connection Methods*

The PCU Ethernet switch to K-Frame Video Processor Ethernet switch cable connection is used for Menu Panel communications. The second cable connects the Panel PCU directly to the K-Frame's Ethernet switch. Using two cables provides additional Ethernet communications throughput (to support Image Store file operations) and also offers redundancy. Because the Menu Panel and the Control Panel have independent cable connections, failure of one of these cables will not completely disable the K-Frame system. Either the Menu Panel or the Control Panel will remain operational after a single network cable failure.

## Kayenne Suites and Control Surfaces

The K-Frame Control Panel system flexibility allows you to locate control surfaces in physically separate locations.

Custom multi-pin cable runs are limited to 15 meters (50 ft.) If this length is sufficient, a single PCU can be used for an entire multi-suite K-Frame system.

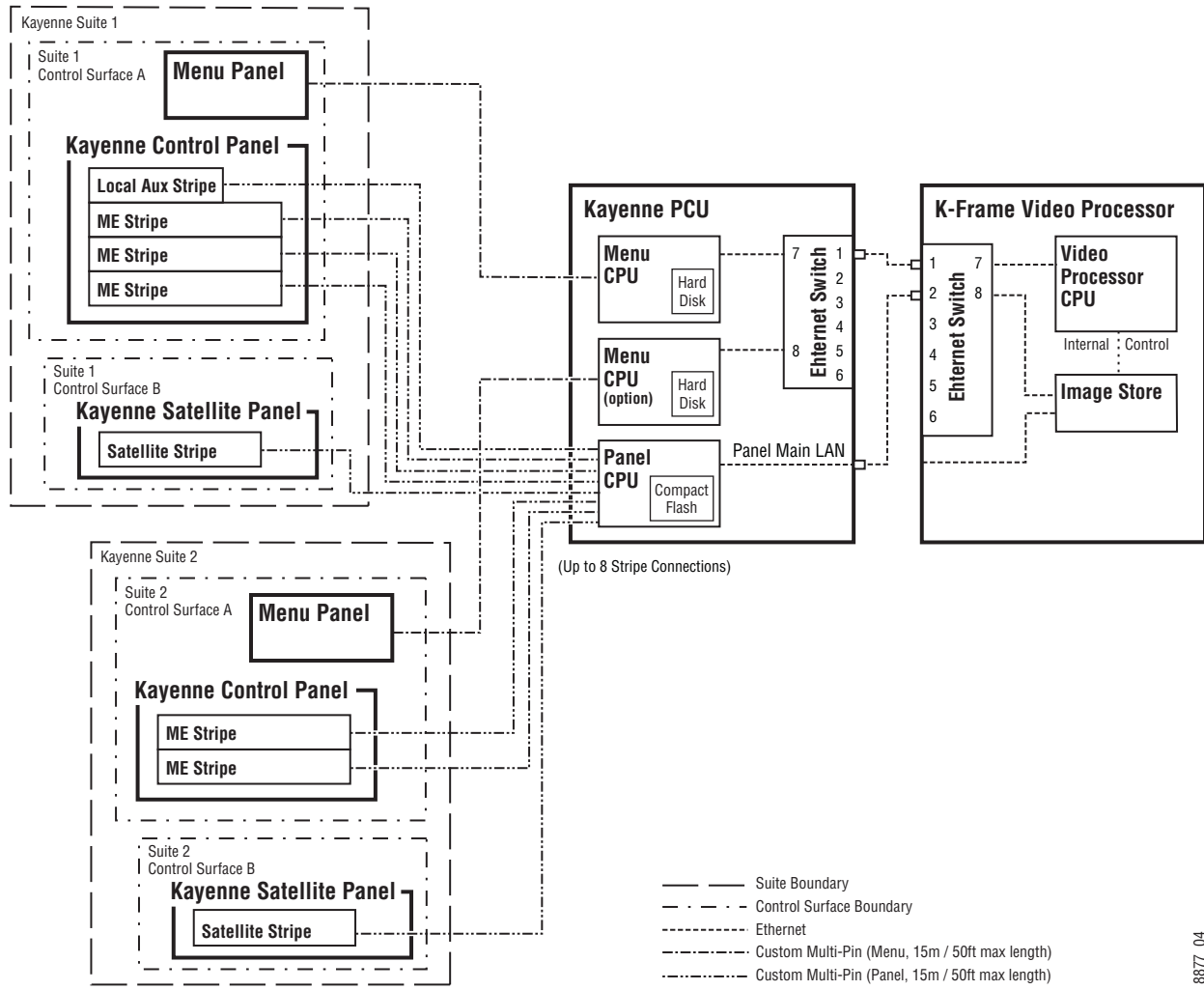

*Two Kayenne K-Frame Suites with Two Control Surfaces Using One PCU*

Using a second PCU, K-Frame suites can be located anywhere on the network, permitting system control from different rooms, floors, or even different buildings.

8877\_04

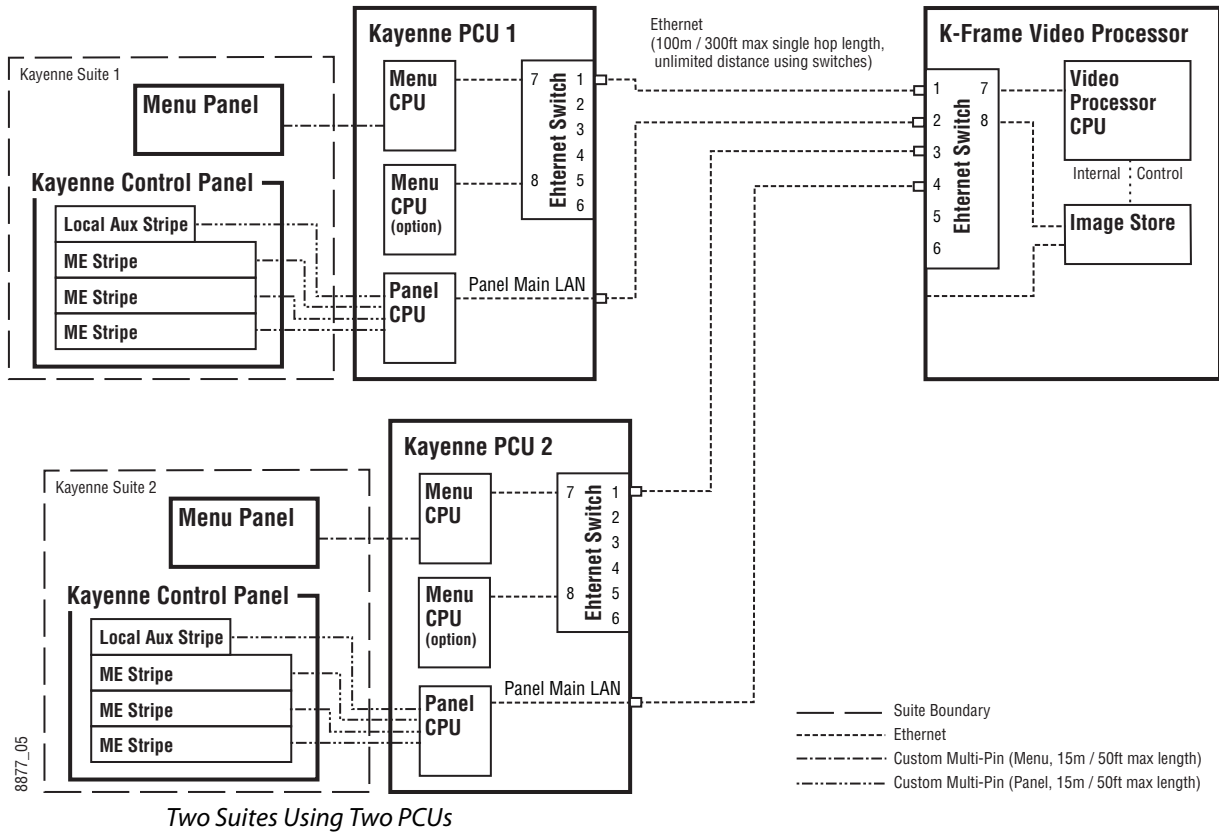

## Kayenne Control Panel Cabling

Connectors on the outside bottom of the Control Panel tray connect to numbered ports on the PCU, using special multi-pin cables that carry both power and communications signals. Special cables are also used to connect the Menu Panels to the PCU.

**CAUTION:** Do not connect or disconnect the multi-pin cables linking a Kayenne Control Panel tray or Menu Panel to the PCU while the PCU is powered up. Damage to the equipment can result.

## Kayenne ME and Local Aux Stripe Connections

It is recommended that the PCU numbered ports be connected to Control Panel Stripes in ascending ME order, followed by the Local Aux Stripe. PCU port connections can be re-

mapped, but this order matches the default configuration. The table below shows the connections for various Kayenne Control Panel models used in a single suite.

**PCU Port to Control Panel Stripe Connections, Single Suite**

Control Panel Model	PCU Port	Panel Stripe
4ME with Local Aux	1	ME 1 (top Stripe)
	2	ME 2 (second Stripe)
	3	ME 3 (third Stripe)
	4	ME 4 (bottom Stripe)
	5	Local Aux Stripe
3ME with Local Aux	1	ME 1 (top Stripe)
	2	ME 2 (second Stripe)
	3	ME 3 (bottom Stripe)
	4	Local Aux Stripe
2ME with Local Aux	1	ME 1 (top Stripe)
	2	ME 2 (bottom Stripe)
	3	Local Aux Stripe
1ME (without Local Aux)	2	Master EMEM, MFM (top tray)
	1	ME (bottom tray)

**Kayenne Satellite Panel Cabling**

**PCU Cabling**

**CAUTION:** Do not connect or disconnect multi-pin PCU cables while the PCU is powered up. Damage to the equipment can result.

Each Satellite Panel has a standard multi-pin cable for connection to the PCU. Modules independent of a particular Stripe (for example Device Control or Master E-MEM modules) can use any available PCU connector.

Modules to be associated with a particular Stripe (like a Transition Module) must be connected to the next higher PCU port for that Stripe. For example, if you wish to use a Transition Module with ME 4 that uses PCU Port 4, plug the Satellite Panel into PCU Port 5, and move the Local Aux Stripe connector (if used) to PCU Port 6.

**Internal Cabling**

**CAUTION:** The RJ-45 connectors inside the Satellite Panel trays are used for proprietary communications only. Ethernet devices may be damaged if plugged into these connectors.

The RJ-45 connectors inside the Satellite Panel trays are used for proprietary communications only. Ethernet devices may be damaged if plugged into these connectors.



The Single Module Satellite Panel has internal module cabling the same as the other Stripes. Simply plug the module into a port using the provided cable.

The Double Module Satellite Panel has a similar internal cabling arrangement, but one cable passes through a hole to the other tray.

### **Kayenne Touch Screen Menu Panels (Used with PCU)**

Connect a single or primary Menu Panel to the PCU **Menu 1** connector, using the supplied custom multi-pin cable. Connect an optional second Menu Panel to the **Menu 2** connector. Menu Panels are assigned to suites during system configuration.

## Karrera K-Frame System Cabling

The Karrera K-Frame system uses Ethernet, serial, DVI, and USB connections for system communications.

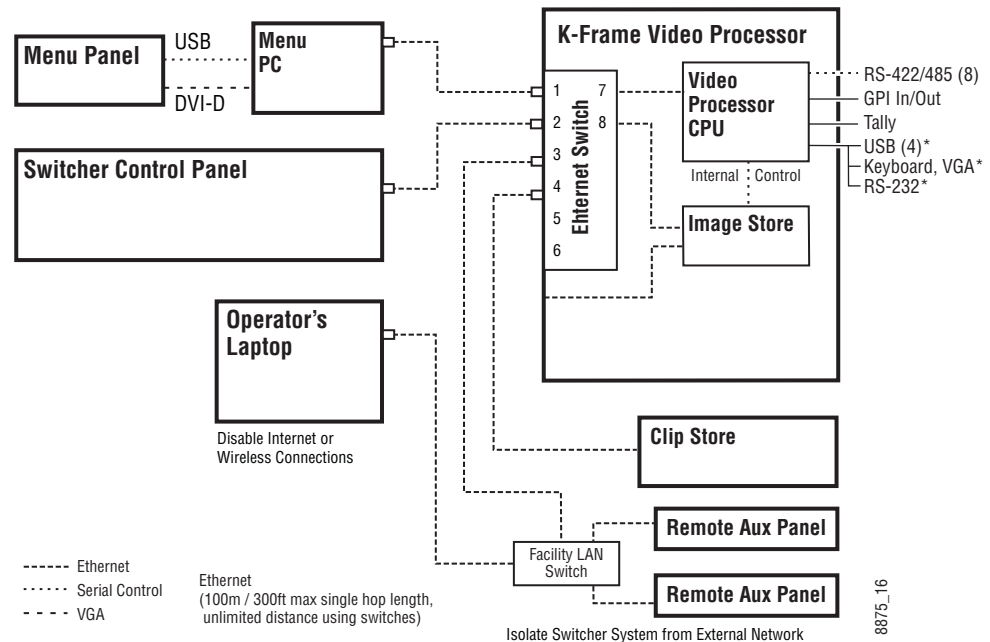

*Karrera K-Frame System Communications Overview*

**CAUTION:** The facility network used for your K-Frame system (and other video production equipment) should be kept separate from any external network, to prevent network traffic from adversely affecting K-Frame system operation.

## Karrera Suites and Control Surfaces

The K-Frame Control Panel system flexibility allows you to locate control surfaces in physically separate locations. Two dedicated, customer supplied Ethernet switches may be required when multiple suites are being used.

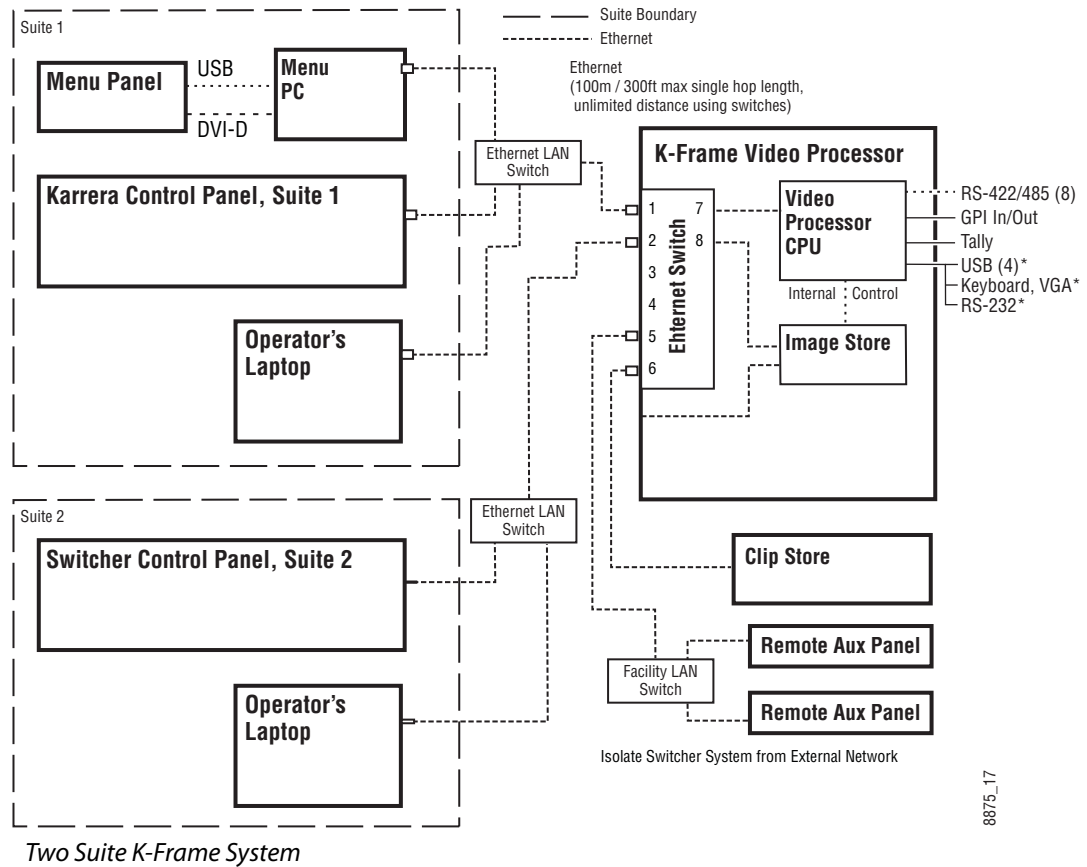

## Karrera Control Panel Network Cabling

Ethernet, USB, and DVI-D connections are used between the K-Frame Video Processor, Control Panel, and optional Menu Panel PC.

## Optional Touch Screen Menu Panel Cabling

Five connections are required for the Touch Screen Menu option. If the articulated arm is used, some of these cables can be routed through channels in the arm that have covers that snaps into place.

System Cabling  
Optional Karrera Local Aux Panel Cabling

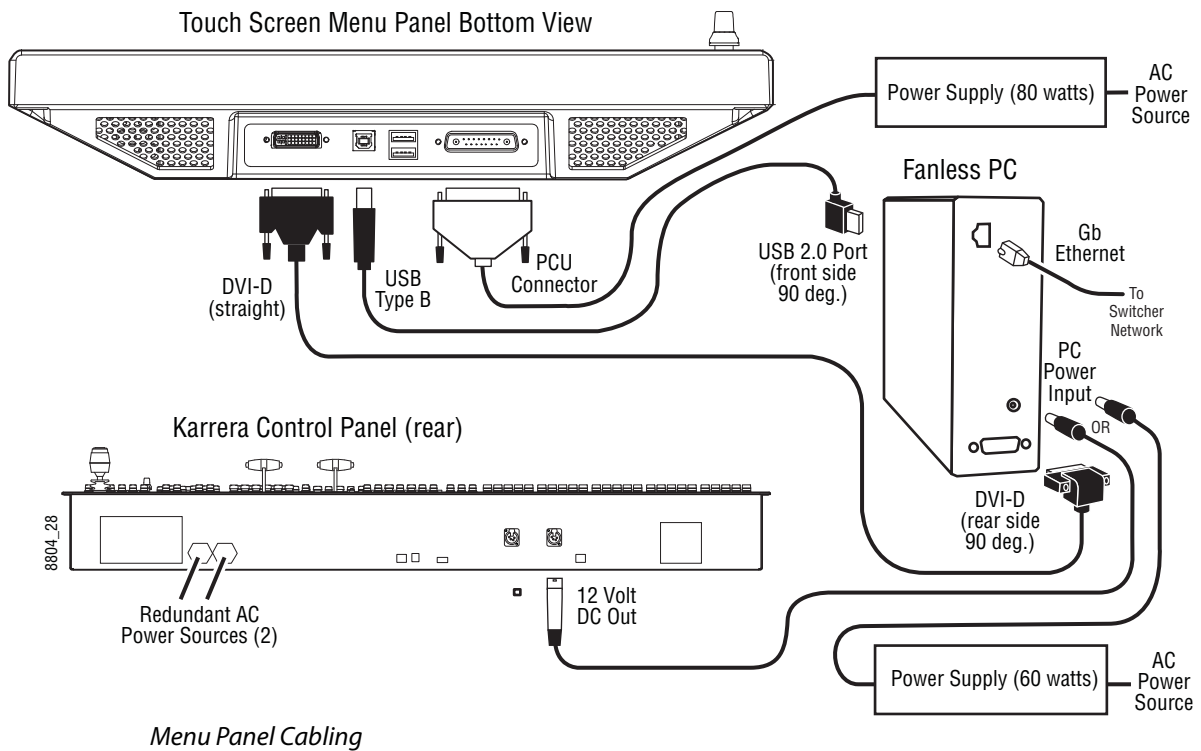

**CAUTION:** Connect the USB port on the front of the Fanless PC (next to the firewire 1394 port) to the Menu Panel. The default PC settings enable knob control by mapping Com 3 to that front USB port.

## Optional Karrera Local Aux Panel Cabling

The Karrera K-Frame Local Aux Panel is powered from the Control Panel, using a 4-pin XLR cable. System control is provided using a RJ-45 connecting cable, which uses a proprietary communications protocol (not Ethernet).

Figure 1. Local Aux Panel Cabling

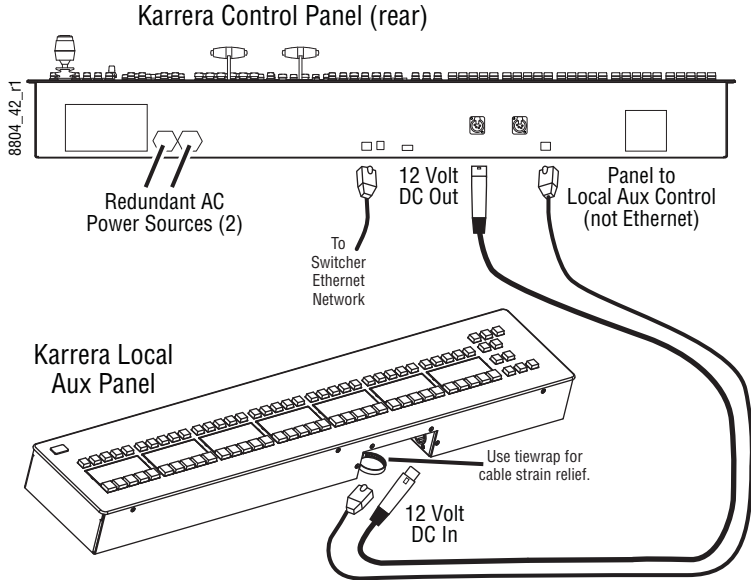

## GV Korona K-Frame System Cabling

The GV Korona K-Frame system uses Ethernet connections for communications. The K-Frame Video Processor has a built-in Ethernet switch. Tally outputs and GPI I/O (General Purpose Interface Input/Output) control are also available on the K-Frame.

**CAUTION:** The facility network used for your K-Frame system (and other video production equipment) should be kept separate from any external network, to prevent network traffic from adversely affecting K-Frame system operation.

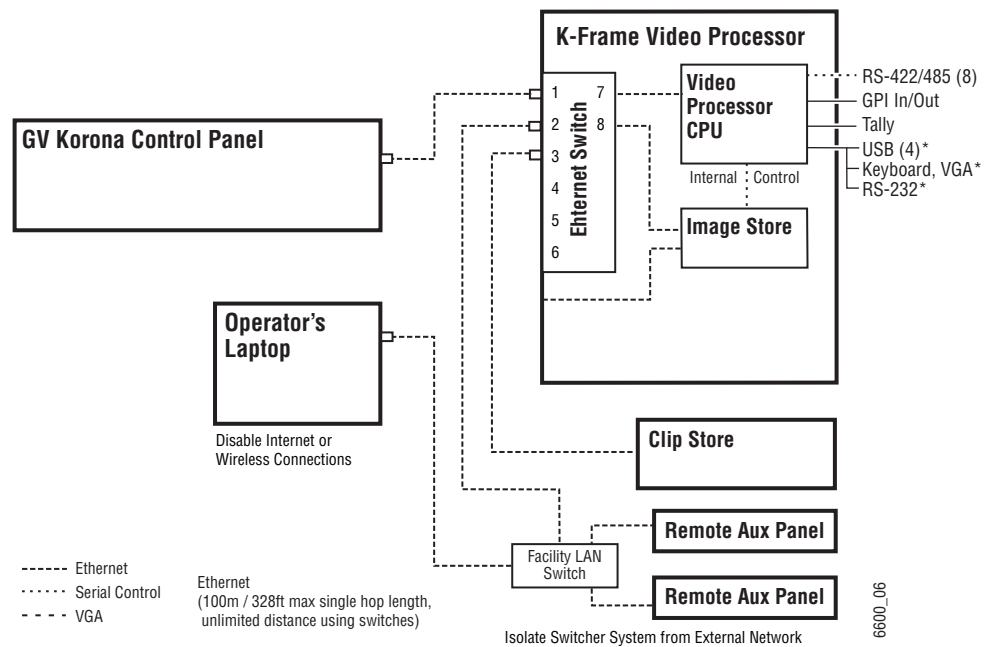

*GV Korona K-Frame System Communications Overview*

## GV Korona Suites and Control Surfaces

The K-Frame Control Panel system flexibility allows you to locate control surfaces in physically separate locations. Two dedicated, customer supplied Ethernet switches may be required when multiple suites are being used.

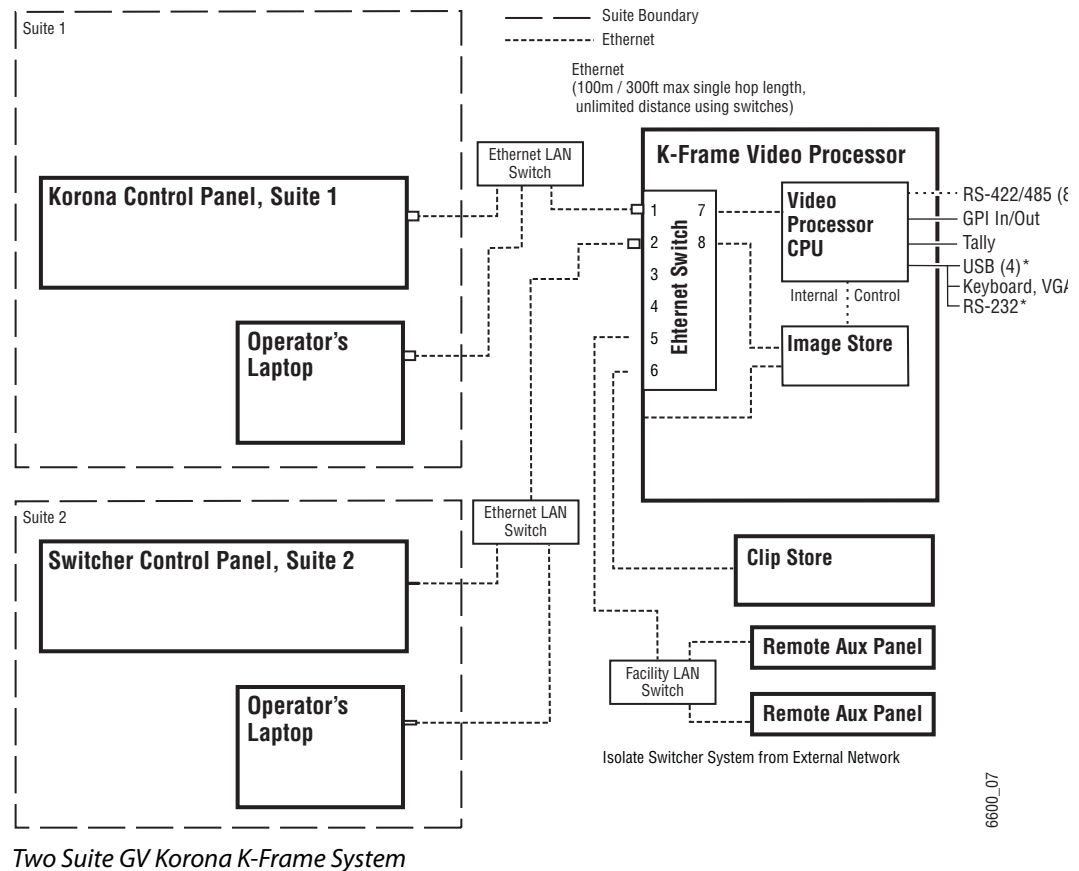

## K-Frame Video Cabling

All K-Frame system video inputs and outputs are configurable. For cabling configuration flexibility, each external primary input can be mapped to any control panel source select button, as can each internal video system source. Any K-Frame system video signal, such as ME program, preview, clean feed, or PGM/PST, can be mapped to any output bus to be sent to any output connector, or an output bus can act as an auxiliary bus.

## Modular 10GigE IP I/O Fiber Optic Cabling

Grass Valley recommends using OM3 (maximum of 300 meters) or OM4 (maximum of 400 meters) Multi-mode Fiber Optic cabling with the 10GBASE-SR Modules provided with the 10GE IP/IO boards.

## Inputs

Non-looping video inputs on the back of the Video Processor Frame are numbered 1 through 32 on each input module. Each accepts a 270 MHz, 1.485 Gb, or 3 Gb serial digital video signal.

## Outputs

Paired outputs on the back of the Video Processor Frame are numbered 1 through 16 on each output module. Identical signals are present on each of the paired output connectors. All of the outputs carry the same video format, as determined by the standard selected and by the reference signals connected.

## Reference Input

The K-Frame Video Processor has digital referencing that can lock to any digital input video signal or one analog looping reference input. Each can be used with any SD/HD/3G/4K standard.

**Note:** The Frame Operating Mode is independent of the reference input and does not follow the input sync rate.

For the analog looping reference input, 75-ohm termination of the looping input can be used either directly, on the adjacent connector, or at the end of a daisy chain looping to other equipment.

Analog Input Sync Rates will show 'Locked' in the Frame Status pane of the Eng Setup, Video Settings menu when the Frame Operating Mode matches a related frequency. For example, a 1080pA/50Hz signal will lock when the Frame is in the 625i/25Hz Frame Operating Mode because 25Hz is 'related' or a divisible of 50Hz.

## K-Frame System Video Timing and Delay

The total delay of a video input to the switcher output can vary according to the relationship of the input to the switcher reference. The switcher will automatically autotiming inputs that fall within an autotiming window. Inputs must be within this range to be properly timed at the output. The calculation of the actual video delay of a specific input is the Nominal Switcher Delay minus the input time location within the autotiming window (the time location value can be zero, positive, or negative).

### K-Frame System Timing, 4-ME System

Frame Operating Mode	A Nominal Switcher Delay	B Autotiming Window	C Minimum Switcher Delay	D Maximum Switcher Delay
525i/29.97	54.91 $\mu$ s	+/- 8.69 $\mu$ s	46.22 $\mu$ s	63.56 $\mu$ s
625i/25	55.10 $\mu$ s	+/- 8.88 $\mu$ s	46.22 $\mu$ s	64.00 $\mu$ s
720p/59.94/60	20.22 $\mu$ s	+/- 2.02 $\mu$ s	18.20 $\mu$ s	22.24 $\mu$ s
720p/50	22.43 $\mu$ s	+/- 4.23 $\mu$ s	18.20 $\mu$ s	26.67 $\mu$ s
1080i-1080psf/29.97/30	23.93 $\mu$ s	+/- 5.73 $\mu$ s	18.20 $\mu$ s	29.66 $\mu$ s
1080i-1080psf/25	26.88 $\mu$ s	+/- 8.68 $\mu$ s	18.20 $\mu$ s	35.56 $\mu$ s
1080psf 23.98/24	27.63 $\mu$ s	+/- 9.43 $\mu$ s	18.20 $\mu$ s	37.04 $\mu$ s
1080pA 59.94/60	11.97 $\mu$ s	+/- 2.87 $\mu$ s	9.1 $\mu$ s	14.83 $\mu$ s
1080pA 50	13.44 $\mu$ s	+/- 4.34 $\mu$ s	9.1 $\mu$ s	17.78 $\mu$ s



### K-Frame System Timing, 4-ME System

Frame Operating Mode	A Nominal Switcher Delay	B Autotiming Window	C Minimum Switcher Delay	D Maximum Switcher Delay
1080pB 59.94/60	20.23 $\mu$ s	+/- 9.44 $\mu$ s	10.79 $\mu$ s	29.66 $\mu$ s
1080pB 50	23.18 $\mu$ s	+/- 12.39 $\mu$ s	10.79 $\mu$ s	35.56 $\mu$ s

A timing diagram of the input autotiming window and various switcher delay values is provided.

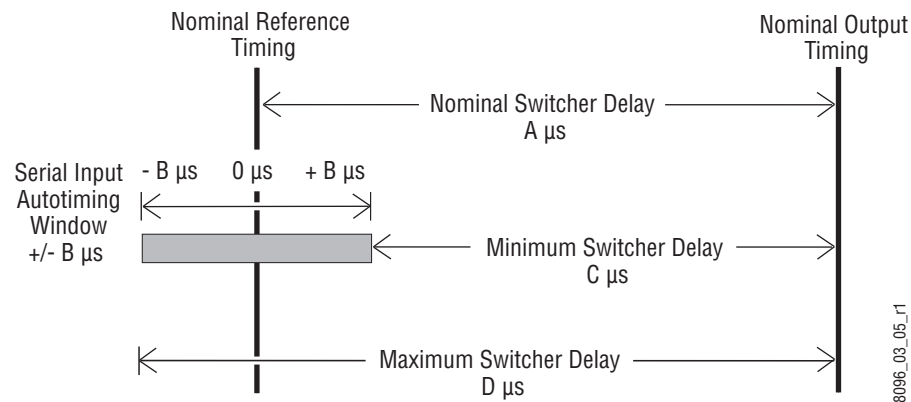

#### Switcher Timing Diagram

- For inputs entering the switcher in zero time with the reference, the total delay through the switcher is the Nominal Switcher Delay (A  $\mu$ s).
- Inputs that reach the switcher at the latest point in the autotiming window (+B  $\mu$ s) will have a total delay that equals the time required for switcher processing. This value is the Minimum Switcher Delay (C  $\mu$ s).
- Inputs that reach the switcher at the earliest point in the autotiming window (-B  $\mu$ s) will have a total delay equal to the Nominal Switcher Delay (A  $\mu$ s) plus the autotiming window range. This value is the Maximum Switcher Delay value (D  $\mu$ s).

On K-Frame systems the autotiming window varies depending on the operating mode. The Timing Analyzer in the Video Settings Menu displays this autotiming information.

**Note:** The maximum switcher delay is approximately one line of video.

## Timing Analyzer

Use the Eng Setup, Video Settings menu when timing the system.

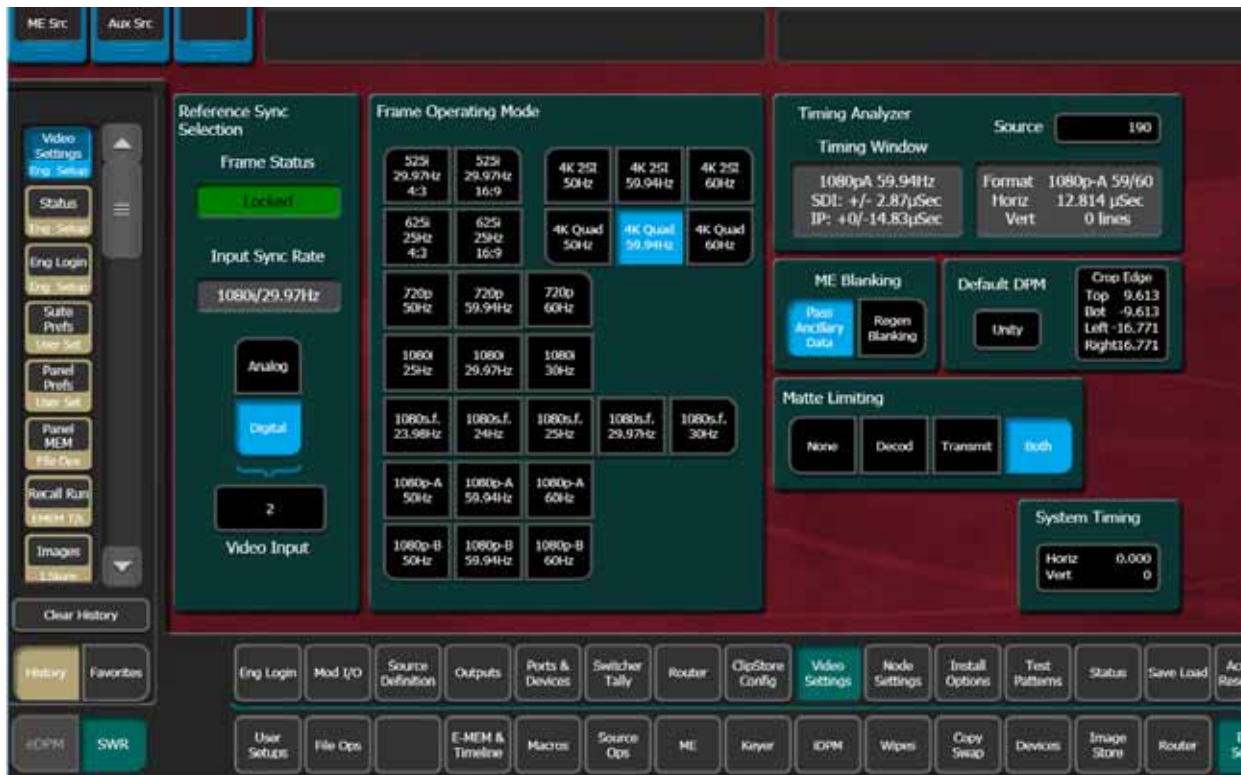

### Video Settings Menu

This analyzer reports the timing position of a selected source relative to the K-Frame internal sync generator. The source is selected with the upper right Analyzer Source soft knob and data pad. The relative position of that source is reported in lines and  $\mu$ s. Positive values indicate the source is later in time than the internal sync generator, and negative values indicate the source is earlier.

Kayenne K-Frame systems have an autotiming window. Sources that fall within that window will be properly timed throughout the Kayenne K-Frame system, even if the signal is cascaded through multiple MEs.

The Switcher Horizontal and Switcher Vertical soft knobs adjust the timing of the Kayenne K-Frame system relative to the incoming reference. These values are generally best left at zero.

## Time Zones and the Autotiming Window

Each ME has a fixed amount of delay from its input to output. To allow reentries to remain in time, ME timings are staggered such that the up stream ME outputs are earlier in time than down stream ME inputs. A 5 ME production switcher has six time zones to accommodate reentry through all the MEs to any output. When all MEs are cascaded into each other, the most up stream ME is in the earliest time zone. Aux buses and other outputs are always in the latest time zone. The overlapping range of all the autotimers is the published autotiming window for the switcher.

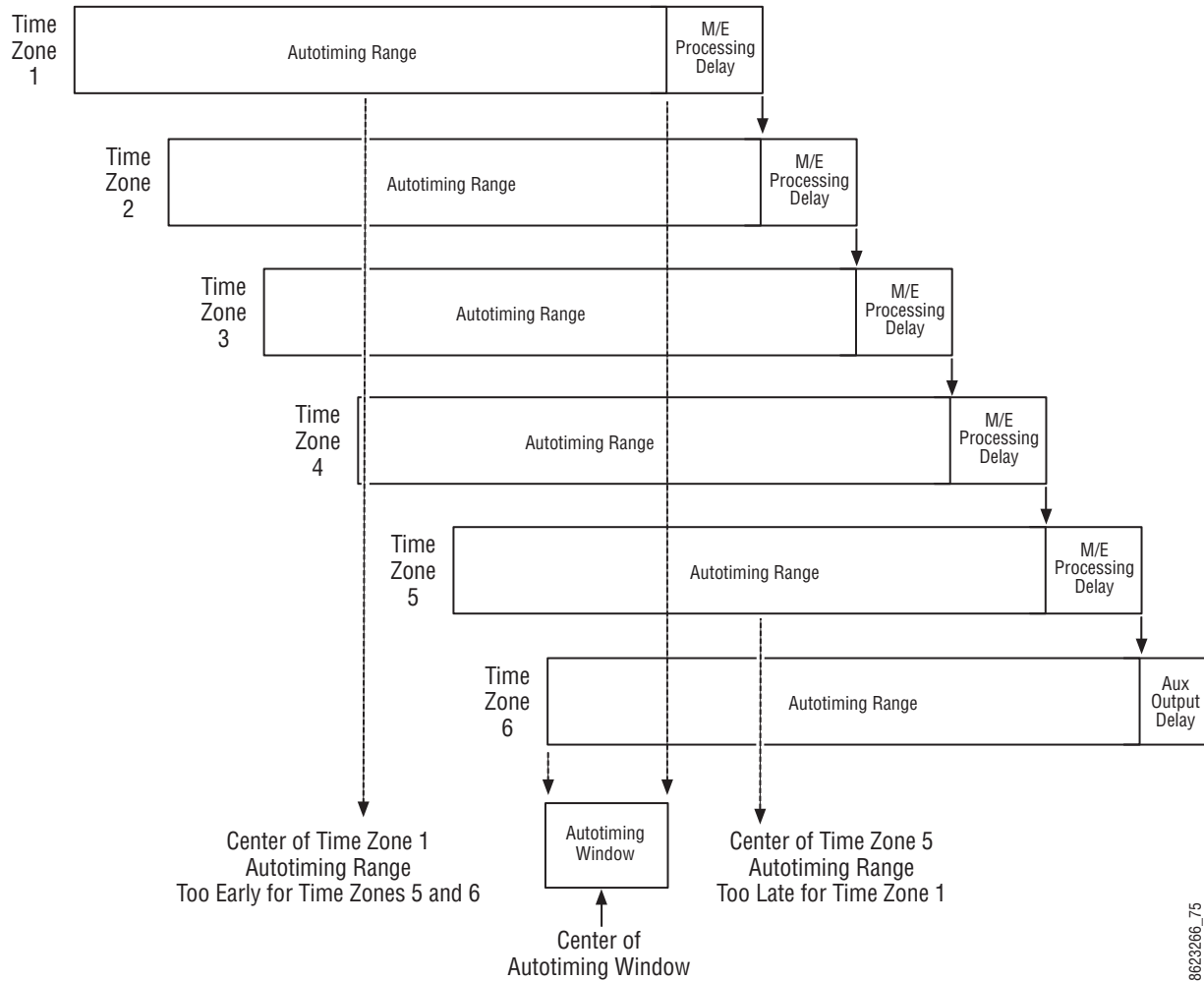

*Production Switcher Time Zones*

Any source fed to the switcher must be within the autotiming range of all six time zones. If not, the source will be in time on some MEs but not on others. As illustrated in the figure, a source centered in one time zone's autotiming range can be too early or late for other switcher time zones.

If a signal falls just outside the autotiming window, that image will be shifted one line up or down. On SD systems a shift of one line could be easily seen, but on higher resolution systems the lines are so narrow that a single line shift may be difficult to observe.

## ClipStore Cabling

The K-Frame system uses an Ethernet connection for communications with ClipStore. Ethernet cables are connected from the K-Frame, either directly or through a dedicated Ethernet switch, to the bottom left (of the four) 100BT/1000BT Ethernet ports on the Summit/Solo backplane. Refer to the K2 Summit/Solo manuals included with the your K2 system.

8623266\_75

## ClipStore Video Cabling

The ClipStore channels on the server backplane are labeled C1-C4 (Channel 1 through Channel 4 on the Summit) from left to right. The Solo backplane is not labeled, Channel 1 is on the left and Channel 2 is on the right when facing the backplane.

ClipStore requires SDI connections for both video and key— two connections In/Out per channel for recording and playback. For playback only, two SDI connections to Out 1 and Out 2 are all that is required per channel.

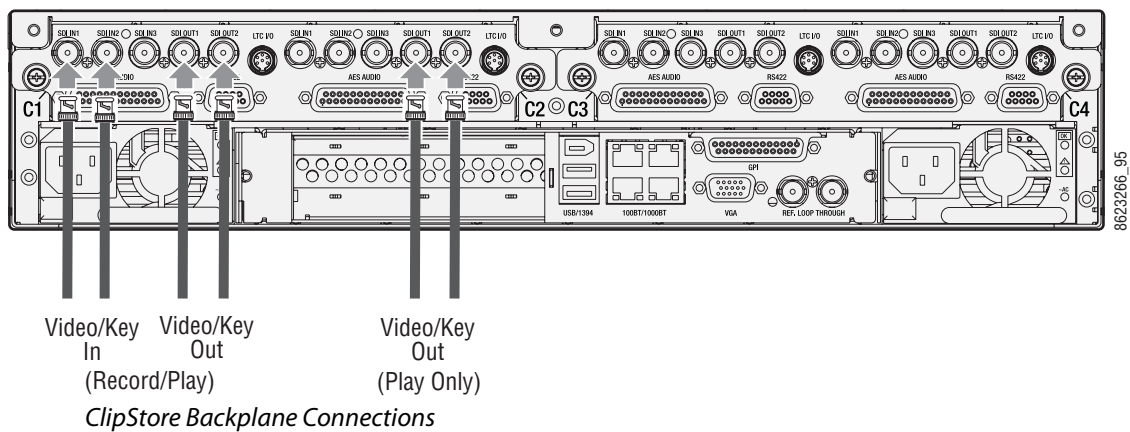

The ClipStore server (4-channel Summit/2-Channel Solo) can be connected directly to the frame. It is also possible to connect to the ClipStore directly from a router and not use any switcher outputs.

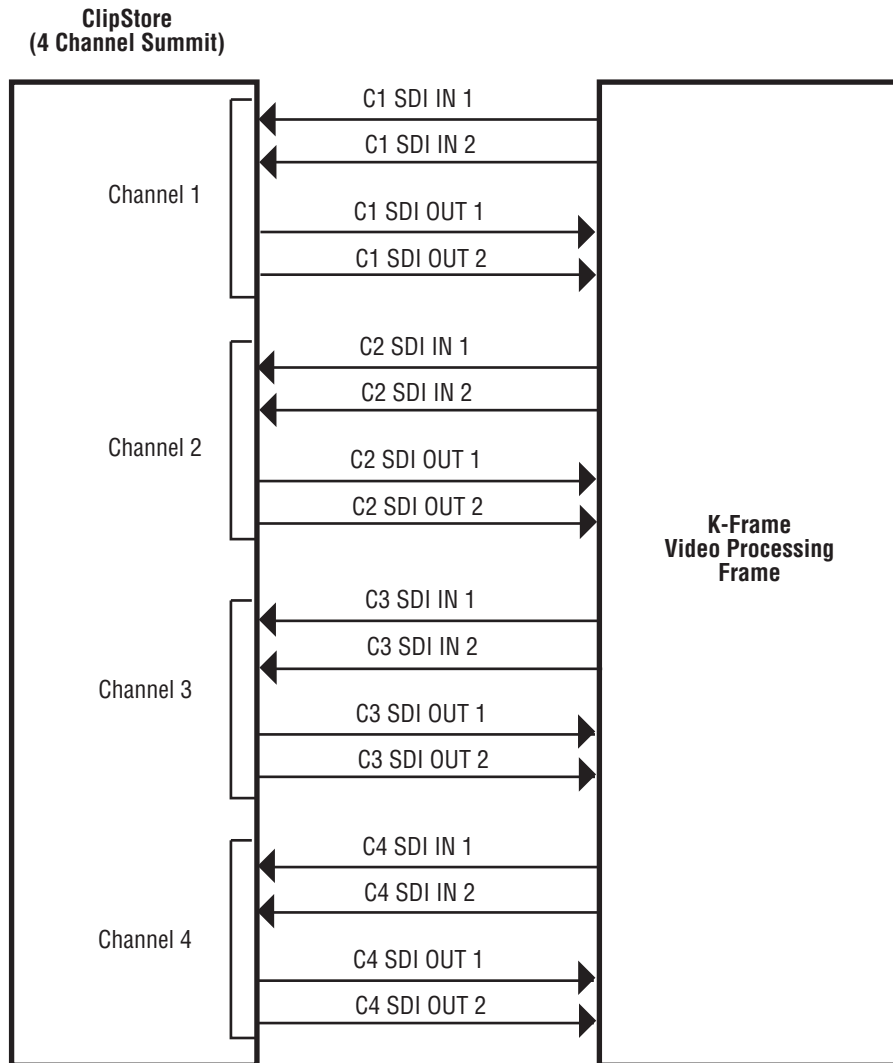

*ClipStore Direct Connection*

Odd numbered outputs are used for fill and even are used for cut. The first output assigned to a ClipStore channel must be an odd numbered output.

Also, DAs (Distribution Amplifiers) can be used to distribute K-Frame Aux Bus output. The example shows DAs being used for both the Video and Key Aux Bus outputs from the frame.

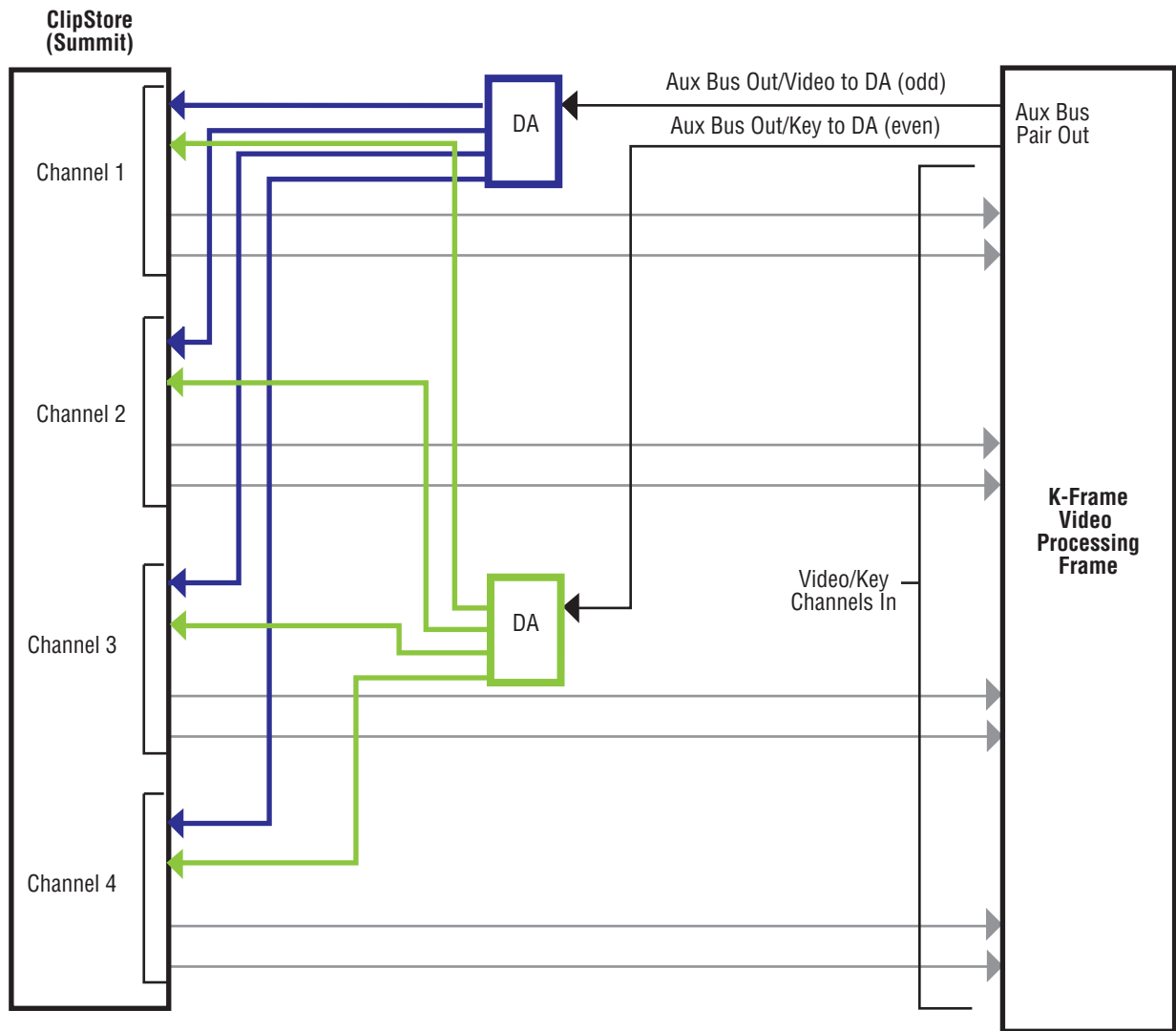

*ClipStore Connection Using Distribution Amplifiers*

## Video Processor Frame GPI/Relay Tally Interface

The GPI (General Purpose Interface) and relay tally interface provides a means to transfer commands to and from the switcher to external devices. A one wire per function parallel hardware relay mechanism is used. The nominal contact rating specification for each relay is 1A, 60 V.

## GPI and Relay Tally Connections

Each K-Frame Video Input module has a 50 pin female sub-miniature D connector on the rear of the chassis, available for GPI and relay tally. Each connector has 8 GPI Inputs, 8 GPI Outputs and 24 Relay Tally Outputs. Relays are in groups of four with a common ground.

The output relays are the same hardware but the GPI is being driven by the GPI output software and the relay tally is driven by the Relay Tally system software. Relay tally connections can be used to trigger GPIs on external devices.

## GPI Inputs

The purpose of the GPI In pins is to provide a stimulus from the external devices to the switcher. A simple connection of two pins activates the corresponding input. An external relay contact or an open-collector output can be employed.

**CAUTION:** When connecting to an open-collector output, there is no ground potential isolation between the Video Processor Frame and controlling devices.

When connecting to an open-collector output, there is no ground potential isolation between the Video Processor Frame and controlling devices.

Since the circuit ground is led out of the device, cabling should be shielded for this kind of control. Non-shielded cables may cause EMC and/or ESD problems. To activate a GPI In you must provide switch closure between a particular GPI In pin and its common (1 or 34). Pins 1 and 34 of each connector is connected to ground. For applications that span across more than one connector, only one ground (common) connection is required.

The following diagram has the GPI inputs on the left.

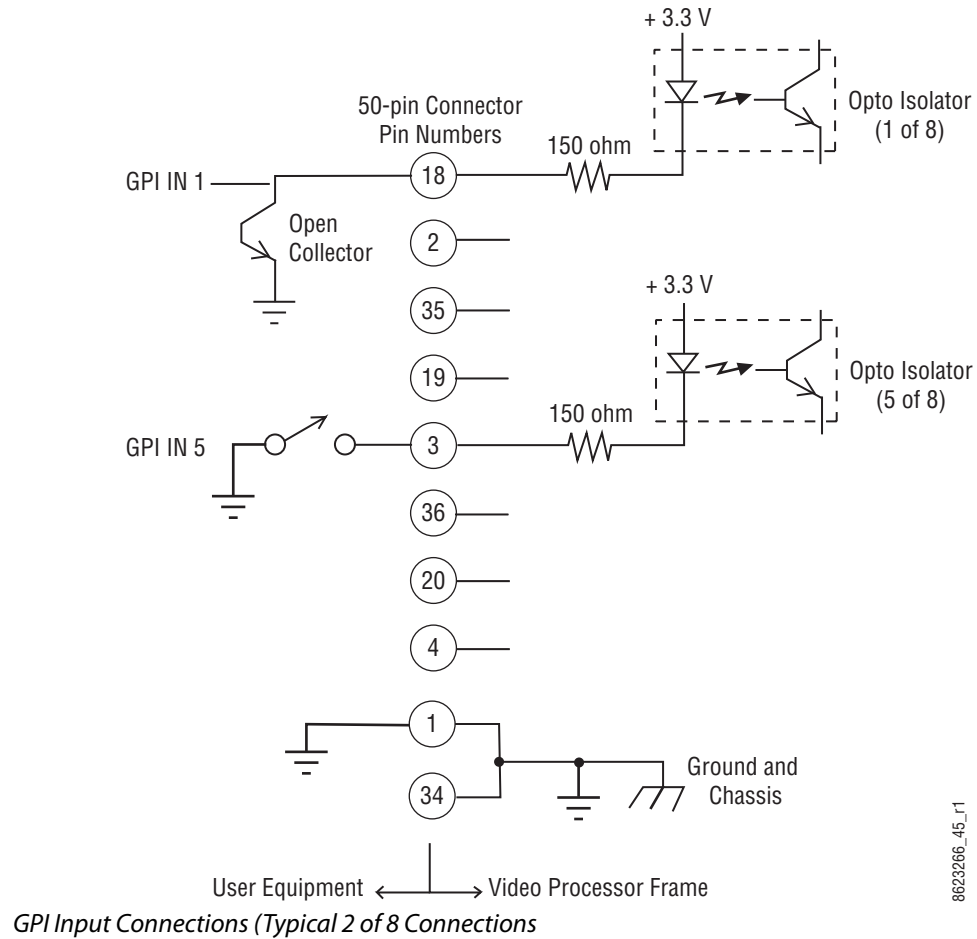

8623266\_45\_r1

## Relay Tally/GPI Outputs

Relay Tally and GPI Outputs are arranged in groups of four. Each group has its own common connection. These commons can all be tied together, forming one common bus for all the outputs. Alternatively, multiple smaller commons can be constructed to interface with systems that need isolated common connections. This common or isolated bus scheme can extend across multiple connectors. For example, a situation may require two isolated common buses, half of the commons form the first common bus and the other half form the second common bus.

The first four outputs have the common bus tied to ground. This drives a logic system. The last outputs have the common bus tied to +12 volts. This drives a relay tally lamp system. All relays can be used to drive logic or control external circuitry.



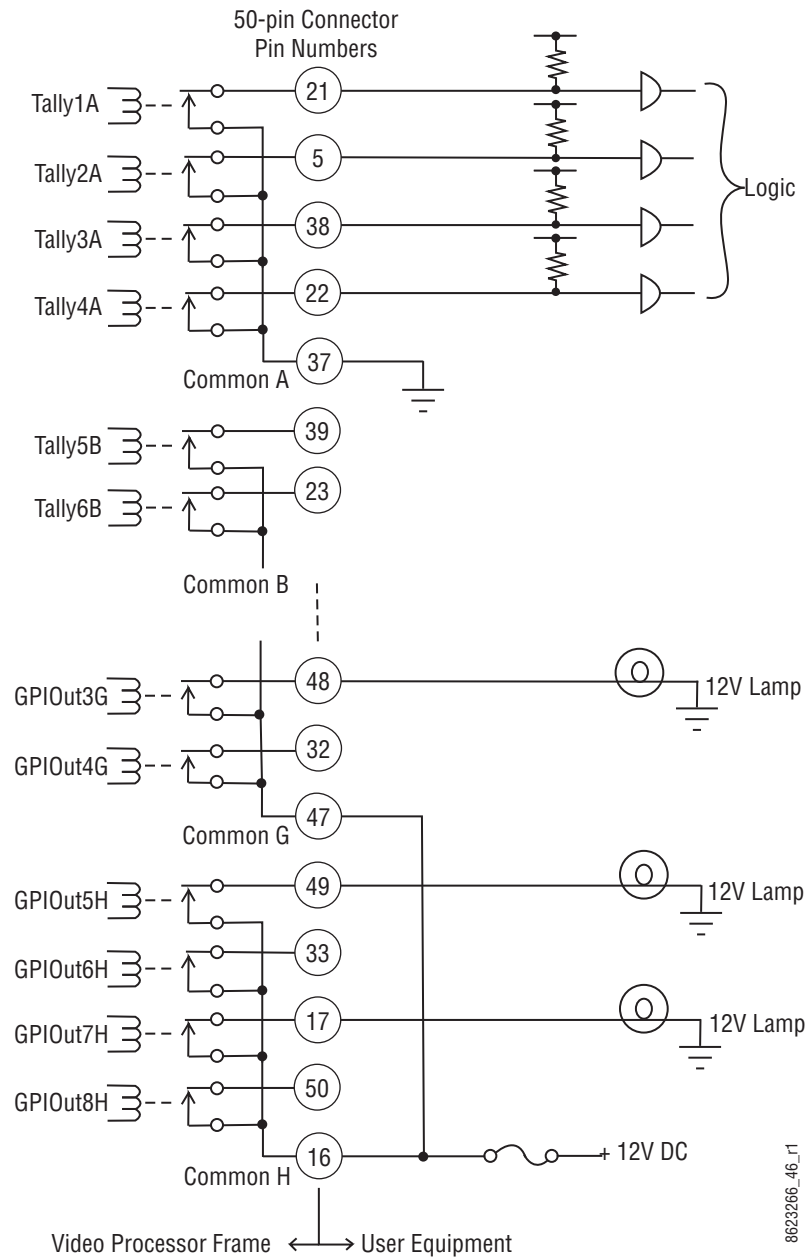

*Relay Tally and GPI Output Connection Example*

Although the diagram shows mechanical relays, the actual outputs are implemented with solid state relays. The solid state relays are bidirectional; either polarity voltage can be applied. If the switcher GPI/Relay Tally outputs are used to drive downstream DC relays, be

sure to install diodes across the relay coils to clamp inductive spikes. Shielded cable is recommended for the connection from the switcher to the user Relay Tally system.

**Relay Tally and GPI Output Specifications**

Maximum current for any one output	1 amp AC/DC
Maximum current for any one common	2 amp AC/DC
Maximum off (open circuit) voltage between output and common	60 Volts peak
Maximum voltage between any point and ground (chassis)	60 Volts peak

**GPI In, GPI Out, Relay Tally Pin Assignments**

Each Input Module has a 50 pin connector for GPI and Relay Tally. The connectors are arranged in left to right order on the rear of the Standard (13-RU) K-Frame, and in top to bottom order on the Compact (6RU) K-Frame.

**Input Module Connectors**

Module Number	Signals	6RU Frame	13RU Frame
1	GPI In 1-8	Yes	Yes
	GPI Out 1-8		
	Relay Tally 1-24		
2	GPI In 9-16	Yes	Yes
	GPI Out 9-16		
	Relay Tally 25-48		
3	GPI In 17-24	No	Yes
	GPI Out 17-24		
	Relay Tally 49-72		
4	GPI In 25-32	No	Yes
	GPI Out 25 - 32		
	Relay Tally 73-96		
5	GPI In 33-40	No	Yes
	GPI Out 33-40		
	Relay Tally 97-120		

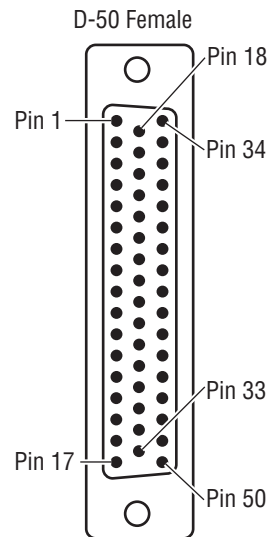

Socket Pinout

**GPI In, Tally, GPI Out Signals**

Ribbon Cable	50-Pin D-Sub			1	2	3	4	5
1	1			GPIInCom	GPIInCom	GPIInCom	GPIInCom	GPIInCom
2			34	GPIInCom	GPIInCom	GPIInCom	GPIInCom	GPIInCom
3		18		GPIIn1	GPIIn9	GPIIn17	GPIIn25	GPIIn33
4	2			GPIIn2	GPIIn10	GPIIn18	GPIIn26	GPIIn34
5			35	GPIIn3	GPIIn11	GPIIn19	GPIIn27	GPIIn35
6		19		GPIIn4	GPIIn12	GPIIn20	GPIIn28	GPIIn36
7	3			GPIIn5	GPIIn13	GPIIn21	GPIIn29	GPIIn37
8			36	GPIIn6	GPIIn14	GPIIn22	GPIIn30	GPIIn38
9		20		GPIIn7	GPIIn15	GPIIn23	GPIIn31	GPIIn39
10	4			GPIIn8	GPIIn16	GPIIn24	GPIIn32	GPIIn40
11			37	TallyComA	TallyComJ	TallyComS	TallyComAA	TallyComAG
12		21		Tally1A	Tally25J	Tally49S	Tally73AA	Tally97AG
13	5			Tally2A	Tally26J	Tally50S	Tally74AA	Tally98AG
14			38	Tally3A	Tally27J	Tally51S	Tally75AA	Tally99AG
15		22		Tally4A	Tally28J	Tally52S	Tally76AA	Tally100AG
16	6			TallyComB	TallyComK	TallyComT	TallyComAB	TallyComAH
17			39	Tally5B	Tally29K	Tally53T	Tally77AB	Tally101AH
18		23		Tally6B	Tally30K	Tally54T	Tally78AB	Tally102AH
19	7			Tally7B	Tally31K	Tally55T	Tally79AB	Tally103AH
20			40	Tally8B	Tally32K	Tally56T	Tally80AB	Tally104AH

## System Cabling

### GPI In, GPI Out, Relay Tally Pin Assignments

#### GPI In, Tally, GPI Out Signals

Ribbon Cable	50-Pin D-Sub		1	2	3	4	5
21		24	TallyComC	TallyComL	TallyComU	TallyComAC	TallyComAJ
22	8		Tally9C	Tally33L	Tally57U	Tally81AC	Tally105AJ
23		41	Tally10C	Tally34L	Tally58U	Tally82AC	Tally106AJ
24		25	Tally11C	Tally35L	Tally59U	Tally83AC	Tally107AJ
25	9		Tally12C	Tally36L	Tally60U	Tally84AC	Tally108AJ
26		42	TallyComD	TallyComM	TallyComV	TallyComAD	TallyComAK
27		26	Tally13D	Tally37M	Tally61V	Tally85AD	Tally109AK
28	10		Tally14D	Tally38M	Tally62V	Tally86AD	Tally110AK
29		43	Tally15D	Tally39M	Tally63V	Tally87AD	Tally111AK
30		27	Tally16D	Tally40M	Tally64V	Tally88AD	Tally112AK
31	11		TallyComE	TallyComN	TallyComW	TallyComAE	TallyComAL
32		44	Tally17E	Tally41N	Tally65W	Tally89AE	Tally113AL
33		28	Tally18E	Tally42N	Tally66W	Tally90AE	Tally114AL
34	12		Tally19E	Tally43N	Tally67W	Tally91AE	Tally115AL
35		45	Tally20E	Tally44N	Tally68W	Tally92AE	Tally116AL
36		29	TallyComF	TallyComP	TallyComX	TallyComAF	TallyComAM
37	13		Tally21F	Tally45P	Tally69X	Tally93AF	Tally117AM
38		46	Tally22F	Tally46P	Tally70X	Tally94AF	Tally118AM
39		30	Tally23F	Tally47P	Tally71X	Tally95AF	Tally119AM
40	14		Tally24F	Tally48P	Tally72X	Tally96AF	Tally120AM
41		47	GPIOutComG	GPIOutComQ	GPIOutComY	GPIOutComAG	GPIOutComAJ
42		31	GPIOut1G	GPIOut9Q	GPIOut17Y	GPIOut25AG	GPIOut33AJ
43	15		GPIOut2G	GPIOut10Q	GPIOut18Y	GPIOut26AG	GPIOut34AJ
44		48	GPIOut3G	GPIOut11Q	GPIOut19Y	GPIOut27AG	GPIOut35AJ
45		32	GPIOut4G	GPIOut12Q	GPIOut20Y	GPIOut28AG	GPIOut36AJ
46	16		GPIOutComH	GPIOutComR	GPIOutComZ	GPIOutComAH	GPIOutComAK
47		49	GPIOut5H	GPIOut13R	GPIOut21Z	GPIOut29AH	GPIOut37AK
48		33	GPIOut6H	GPIOut14R	GPIOut22Z	GPIOut30AH	GPIOut38AK
49	17		GPIOut7H	GPIOut15R	GPIOut23Z	GPIOut31AH	GPIOut39AK
50		50	GPIOut8H	GPIOut16R	GPIOut24Z	GPIOut32AH	GPIOut40AK

## RS-422/485 Port Pin Assignments

Eight RS-422/485 ports are available on the rear of the K-Frame Video Processor, and can be used to control various devices, or for switcher control by an external controller.

**Note:** The Frame serial port pinout is automatically configured based on assignment. The Frame is the bus controller when controlling external devices and PBus. The Frame is a tributary when controlled by an editor.

### RS-422/485 Pinouts

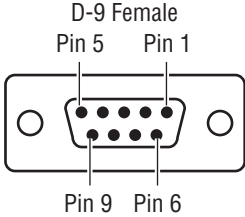
Socket	Pin	Bus Controller	Tributary
 <p>D-9 Female Pin 5 Pin 1 Pin 9 Pin 6</p>	1	Chassis Ground	Chassis Ground
	2	RxA (-)	TxA (-)
	3	TxB (+)	RxB (+)
	4	Signal Ground	Signal Ground
	5	Not used	Not used
	6	Signal Ground	Signal Ground
	7	RxB (+)	TxB (+)
	8	TxA (-)	RxA (-)
	9	Chassis Ground	Chassis Ground

## RS-232 Port Pin Assignments

RS-232 serial ports are located on each processor board (Video Processor, Panel Processor, Menu PC), available for maintenance and diagnostics. Standard VGA and keyboard ports, present on all processor boards, are also available for maintenance.

### RS-232 Pinouts

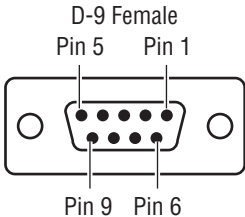
Socket	Pin	Signal
 <p>D-9 Female Pin 5 Pin 1 Pin 9 Pin 6</p>	1	Chassis Ground
	2	Transmit Data
	3	Receive Data
	4	Not used
	5	Signal Ground
	6	Not used
	7	Clear to Send
	8	Request to Send
	9	Not used



# 5 Basic Configuration

## Introduction

This section provides basic system configuration information for the K-Frame Video Production Center. Refer to the *K-Frame 10.0 or newer User Manual* for information specific to your current software version.

## Configuration Steps

K-Frame basic system configuration includes the following steps:

- 1 Power up the system.
- 2 Set IP addresses for your facility (if not using defaults). Node Settings will also need to be configured for proper system communications.
- 3 If necessary, adjust Control Panel button and display illumination.
- 4 If necessary, calibrate Control Panel lever arms and joystick (see *Maintenance* section).
- 5 Define your basic Engineering Setups. Essential settings include:
  - Source Definition
  - Outputs
  - Tally
- 6 Define a baseline User Setups (Panel Prefs and Suite Prefs). Important settings include:
  - Button Mapping
  - Source Patching
  - Default Keyframe
- 7 Configure external devices with the K-Frame system.
- 8 Save your configuration files.
- 9 Additional configuration will be required if multiple suites are being used.

## K-Frame Configuration Data

Current configuration settings reside on the Video Processor Frame (in the NV folder on the Compact Flash drive on the Processor Board). These settings affect K-Frame system operation. When the Video Processor resets, these settings are read and enacted. Configuration settings can be saved to files and loaded back into the K-Frame system at a later time to restore those operational settings.

K-Frame configuration data falls into a few basic categories:

## Eng Setup

Engineering Setup defines basic K-Frame system functionality, including how it is cabled into a facility. Eng Setup applies to the entire system and can affect both suites if a second suite has been configured. Engineering Setups are intended to be used and maintained by technical staff. These parameters are typically set once and seldom changed, unless the facility changes in some way (new devices installed, signals rerouted, etc.).

## User Setups

User Setups can customize K-Frame system behavior for personal preferences, and to meet workflow requirements of a particular show. These settings are divided into **Panel Prefs** and **Suite Prefs**.

- Panel Prefs affects how a specific control surface operates for an individual user, including Button Mapping, Source Colors, etc. These settings apply to a single control surface.
- Suite Prefs controls more fundamental system behavior like Resource Allocation, Source Patching, E-MEM Prefs, etc. These settings apply to all control surfaces within that suite, and so can affect multiple operators. On systems configured with multiple suites, each suite will have its own independent Suite Prefs settings.

## Network IPs and Node Settings

The K-Frame system employs Ethernet IP communications. IP addresses are set on the Video Processor Frame, Image Store, Control Panel, and Menu Panel. The Video Processor Frame maintains a list of IP nodes to enable communication with the other devices in the system. This list is stored separately from the Eng Setup and User Setups configuration files. This permits loading these configuration files without the danger of accidentally disrupting system communications.

One exception is Remote Aux Panel IP network settings, which are stored in the Eng Setup configuration file, along with other Remote Aux Panel settings.

## GV Switcher Menu Application

---

Note: A brief description of the GV Switcher menu application is presented here. Refer to the separate *K-Frame User Manual* for detailed information.

---

The GV Switcher menu application is used to configure your K-Frame system. This application can run on a user-supplied PC, using a mouse and keyboard, and can run on the Touch Screen menu, allowing system operation by touching the screen.

The GV Switcher system menus are context sensitive. They display different information and provide various types of controls depending on what area of the system is involved.



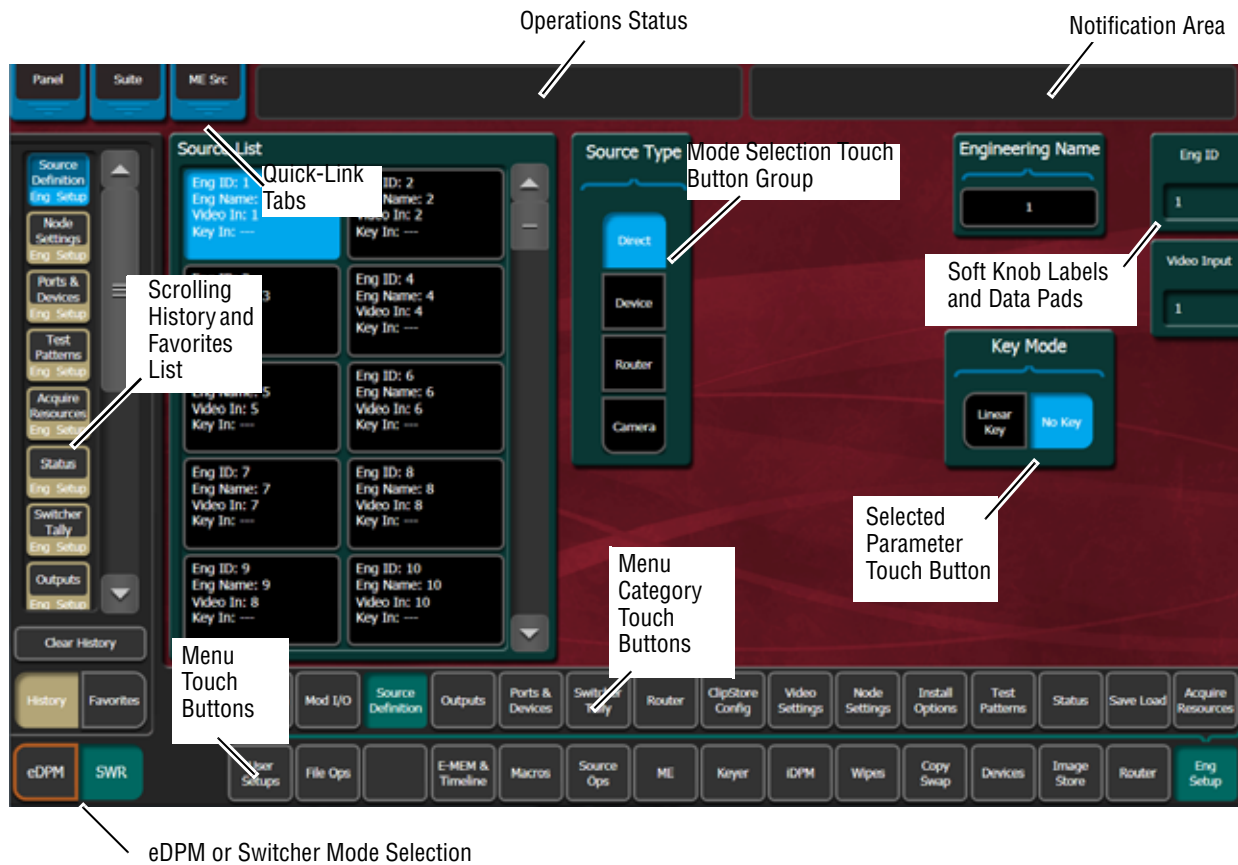

## Menu Top Line

The top line is identical in all the GV Switcher system menus:

- The left portion of the top line has three **Quick-Link Tabs**, which provide access to other related GV Switcher menus.
- The center portion of the top line displays operations status messages.
- The right portion of the top line is an operator notification area, where messages generated by the K-Frame system are displayed.

## Data Pads and Touch Buttons

Data pads are active areas on the screen that display a summary of the status of an object, and when clicked or touched bring up additional controls and information for that object.

Touch buttons are labeled by their function and do not display data. Clicking or touching these buttons will immediately activate their function.

Touch buttons can control on/off functions, and have an indicator on the left side, or they can select from a group of parameters, and turn light blue to indicate the state of that parameter. For on/off buttons, green indicates this is a normal parameter and that either an

on or off state is typical. Yellow indicates an active function that may change expected behavior. Red indicates an active function which significantly changes normal behavior.

## Data Pads and Soft Knobs

Data pads on the right side of the screen allow adjusting parameters with ranges of values. Left clicking or touching a data pad opens a numeric keypad, allowing entry of a specific value.

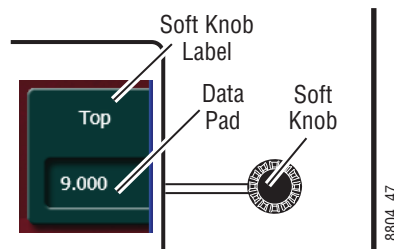

When equipped with a Touch Screen Menu Panel, knobs along the right side of the panel can be used to dial in parameter values for functions displayed. When a knob is active, the touch screen shows the parameter name and its current value on that data pad.

## Menu Selection

Various GV Switcher system operating menus are selected using the menu buttons at the bottom of the Menu panel touch screen. Menu category selection touch buttons are directly above the Menu touch buttons. Touching one of these buttons displays that category.

As each menu is accessed, a button for it appears in the scrolling **History** pane on the left, providing a quick return to that menu. **Favorites** can also be programmed for quick access to specific menus that are not overwritten.

---

**Note:** The optional eDPM system has its own set of operating menus, accessed by touching the **eDPM** button on the lower left. For basic K-Frame configuration be sure the **SWR** button is selected.

---

## Power Up and Initialize the System

The Video Processor Frame, Control Panel, and menu application must be running for full system operation.

- 1 Turn on the Video Processor power switch located inside the front door of the Frame, on the front of the control board (see the *K-Frame Installation & Service Manual*).

---

**CAUTION:** The front doors of the Video Processor Frame must remain closed during normal system operation for proper cooling airflow.

---

- 2 Turn on the PCU power switch located inside the front door, near the center of the upper board of the unit.
- 3 Turn on the Menu Panel (Kayenne and Karrera K-Frame only) and/or customer supplied PC and monitor running the GV Switcher menu application.

## Power and Initialization Indications

Power to the system is indicated by operation of the fans in the Video Processor Frame, illuminated buttons on the Control Panel, and a K-Frame screen is displayed on the Menu Panel.

## K-Frame Menu Application Initialization

When the GV Switcher menu application initialization completes, the Status menu is displayed. This menu reports any connected devices, IP addresses, and software versions and dates of those devices in the center of the screen.

## Default K-Frame System Communications

K-Frame systems ship with factory default settings that allow components to communicate with one another when powered up, provided they are connected properly. These K-Frame components appear on the Status menu.

We recommend you use an isolated Ethernet network with your K-Frame system (to prevent possible IP address or network traffic conflicts), particularly when first setting up your system.

## Establishing Menu to Frame Communication

If a Video Processor Frame is not found by the GV Switcher menu application, the Status menu central window will be empty and a NO FRAME COM message will be displayed in the upper right Notification Area.

The following conditions need to be met before the GV Switcher menu application can communicate with the Video Processor Frame. This list assumes the K-Frame Touch Screen Menu Panel is being used. Similar requirements apply when the GV Switcher menu application is run on a PC:

- The Video Processor Frame must be powered up and running.
- The IP address of the K-Frame Menu Panel (Kayenne and Karrera K-Frame only) is on the same network as the Video Processor Frame.
- Ethernet cabling should connect the Control Panel to the Video Processor Frame, either directly or through an Ethernet switch.
- The IP Address the menu application will use to communicate with the Frame must be in the Frame IP Address field of the Eng Setup, Frame Suite Nodes & ID menu.

---

Note: For GV Korona K-Frame, the same IP Address is used for both the Control Panel and built-in Touch Menu.

---

- The Menu Panel's IP address (Kayenne and Karrera K-Frame only) must be in the IP Address field of the Control Surfaces menu (to register that Menu Panel as a node on the Frame).

## Connecting the Menu Application to a Frame

Use the following procedure to connect the menu application to a Video Processor Frame. Two menu application resets will be required, one to connect to the Frame and another to register the menu application IP with that Frame:

- 1 Select **Eng Setup, Node Settings, Frame Suites Nodes & ID** in the GV switcher menu.
- 2 Select the **Frame IP Address** data pad and enter the Frame's IP Address in the pop-up keypad and select **Enter**.

Result: A Restart menu dialog box will appear.

- 3 You can either select **Restart Now** to restart menu application or select **Cancel**, make changes to the Image Store IP Address and Track DPOPs from Panel IP, and then restart the menu.
- 4 After the menu application restarts, select **Node Settings, Control Surfaces**. This is the only GV switcher menu that will be active when the menu is not registered with the Frame.
- 5 Select a Node Name data pad and enter a descriptive name for the menu application, using the pop-up keyboard and select **Enter**.
- 6 Select the IP Address data pad associated with the Node Name enter its IP Address using the pop-up keypad.
- 7 Select the **Status** menu button to exit the menu.

Result: A Restart menu dialog box will appear.

- 8 Select **Restart Now**.

Result: The Status menu displays the Video Processor Frame and menu as fully operational.

## About Network Configuration

Grass Valley recommends putting Switcher systems on an isolated internal network with direct connections from the Control Panels and menu application to the Video Processor's internal Ethernet switch.

**CAUTION:** Grass Valley does *not* recommend putting Switcher systems on a domain which could expose the control LAN to a WAN or the Internet.

## IP Address Background Information

Each device connected to any Ethernet network must have a unique IP address. An IP address has two components: the network address and the node address. The Subnet mask defines the dividing line between the two. The first three octets of Subnet mask provide the network address; the fourth is the node address. Nodes with the same network address can

communicate directly with each other, while nodes with different network addresses normally do not communicate directly.

The K-Frame system uses Ethernet switches built into the Video Processor Frame. The switch provides isolation between port pairs, providing deterministic communication for panel and frame messaging, and also allows Control Panel and Menu Panel communication for DPOPs. All nodes must also have the same network address and be given a different node address.

## Gateway IP Addresses

A gateway IP address can be entered to allow communication with devices not located on the local K-Frame system network. Communication outside the local network requires using a configured network gateway server, a description of which is beyond the scope of this document. See your network administrator for information about gateway server installation and configuration.

## K-Frame Default IP Addresses On Isolated Network

Each K-Frame system is shipped with default IP addresses. Grass Valley has chosen these default IP addresses to make K-Frame configuration easy. K-Frame devices should communicate with each other right out of the box when properly connected on an isolated network.

## Connecting to an Existing Network

Additional network configuration is required if you connect the K-Frame Ethernet LAN to your facility Ethernet backbone, install additional K-Frame system components, or have multiple K-Frame systems on the same network cabling. For example, if more than one system resides on the same network, the IP address of each additional K-Frame device must be changed before it is connected to the network.

To enable communication between K-Frame and other facility devices, you will need to change the system default network addresses to match the facility address, or place a router between K-Frame and the facility networks. This complexity of network configuration is beyond the scope of this manual. Consult a networking expert if such networking is desired.

See your network System Administrator before connecting the K-Frame system to an existing network or making any IP address changes. The IP addresses (including any Subnet mask) of all the K-Frame devices on the network must be known before any changes are made.

## Setting IPs with the K-Frame Switcher Installer Program

The K-Frame Switcher Installer Program can be used to set IP addresses of the K-Frame Video Processor and Control Panels. When the K-Frame Deployment Tool is installed by opening the K-FrameSetup.exe executable, the K-Frame Installer icon will appear on the desktop.

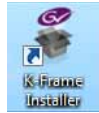

---

Note: A mouse and keyboard is required to navigate through the K-Frame Installer program and enter IP Addresses and system names. Standard USB devices can be connected to available ports on the Kayenne/Karrera K-Frame Menu Panel or GV Korona Control Panel.

---

## K-Frame System Names

The K-Frame Installer program includes a hierarchy display of K-Frame system components. This hierarchy starts with the name of the K-Frame system, and groups that system's Video Processor Frame with the Control Panel(s) configured with that Frame. The system name is taken from the Video Processor Frame name. This hierarchy allows easy identification of each K-Frame system when multiple systems reside on the same network.

K

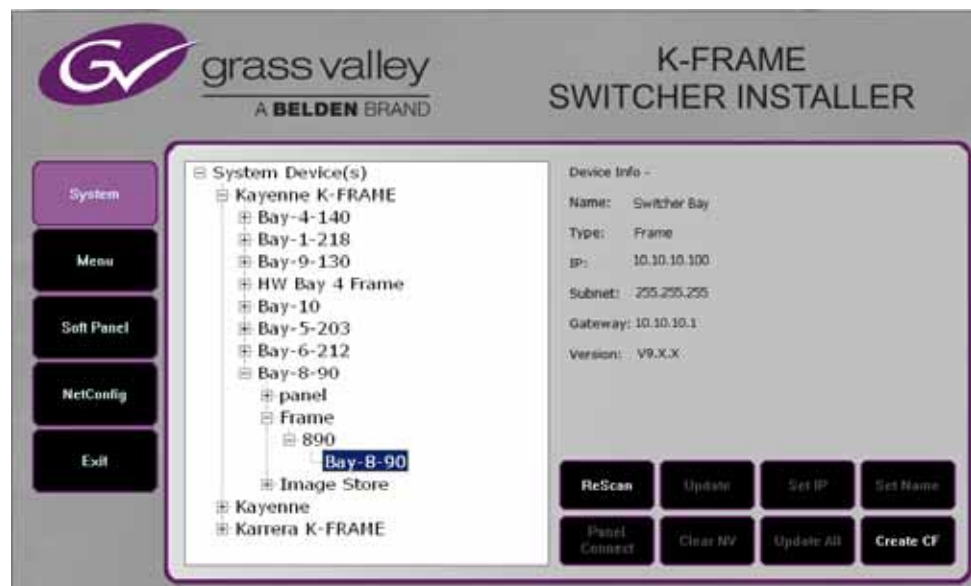

The default name for every K-Frame Video Processor is "SystemA", and this works well when only one system is present on the network. However, if more than one K-Frame system with the default name is present, all the Frames and Control Panels will be grouped under that name.

If you have more than one system, be sure to change the name of the Video Processor Frames so you can identify them easily. When each Frame has a unique name, the Control Panels configured with each Frame will be grouped with that system name.

The name of a K-Frame Video Processor (and K-Frame system name) can be changed in several ways. Once changed by any method, any properly refreshed user display will report that changed name. The Video Processor Frame name can be changed with:

- K-Frame Switcher Installer Program,

- Video Processor Frame web page,
- GV Switcher menu Application Frame Suite Nodes & ID menu, and
- NetConfig.

## Set IP Procedure Using the K-Frame Installer Program

- 1 Ensure the device with the menu application has an IP address able to communicate with the K-Frame system components and is physically connected to the K-Frame network.
- 2 Double click on the **K-Frame Installer** icon. The K-Frame Switcher Installer program will be launched.

**Note:** The K-Frame Switcher Installer program cannot run if the separate NetConfig application or any monitoring program is also being run simultaneously on the same device running the menu application.

- 3 Click on the **System** button on the left to open a hierarchy display of the K-Frame systems. Each system consists of a Video Processor Frame and associated Control Panel(s). Use the mouse to navigate to the desired component.

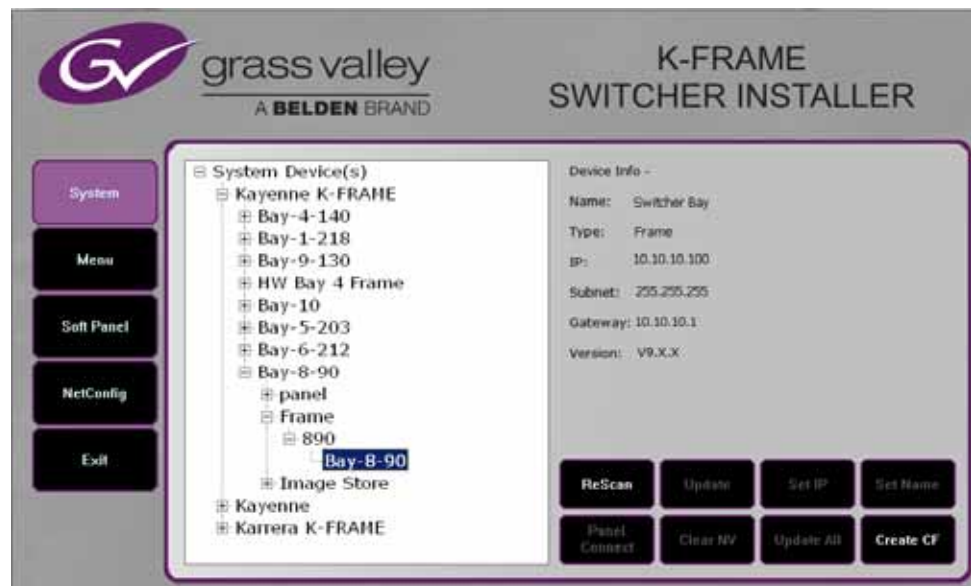

- 4 Click the **Set IP** button to open an IP Address entry window.

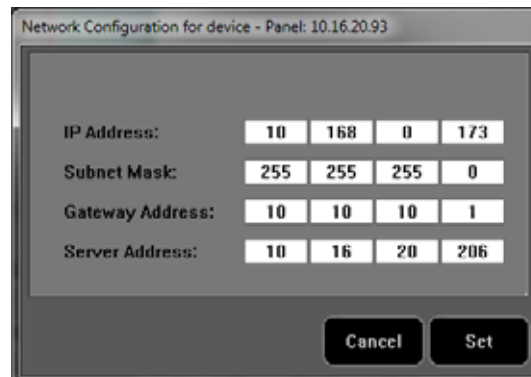

- 5 Click on each field to be changed, type in the desired IP address, and click **Set**.
- 6 The component will need to be reset to make the IP address change take effect. Press the reset button on the Video Processor Frame, or the Panel Reset button (the one on the left) or on the PCU (Kayenne K-Frame only) to reset the device (see the *K-Frame Installation & Service Manual*).

**CAUTION:** Changing the IP address of an operating K-Frame component can disrupt system communications until matching changes to the addresses other components use are made on those other devices. Registering new IP Node addresses may also be necessary.

## Other K-Frame Switcher Installer Program Functions

The K-Frame Switcher Installer program can also be used to install the KSP and NetConfig applications on that PC, using the buttons on the left.

In addition the K-Frame Switcher Installer application has the following other features, accessed by clicking on its labeled button:

**Rescan** - Re-scans the network for devices. This refreshes the screen to show the currently connected components and any modified system names.

**Update** - Updates the software on the selected device using the software deployed with this K-Frame Switcher Installer version.

**Set Name** - Opens a window allowing you to change the name of the selected device.

**Set Server** - (Control Panel selected in hierarchy window) - Opens a window allowing you to enter the IP address the Control Panel will use to communicate with the Video Processor Frame.

**Clear NV** - (Frame or Control Panel selected) Clears NV Memory.

**Update All** - (System selected) Updates software to all devices for the selected system, excluding menus.

**Create CF** - Allows the duplication of a Frame or Control Panel Compact Flash Card onto another CF Card.



## Set the IPs Using Device Web Pages

You need to know the current IP address of the K-Frame Video Processor or Control Panel before you can change it using a Web browser, mouse and keyboard.

Note: The NetConfig application, included with the K-Frame software, can be used to find IP Addresses of devices accessible on the network. Refer to the separate *NetConfig Instruction Manual* for more information.

- 1 Using any web browser connected to your K-Frame network, enter the IP Address of the device in the IP Address field and press **Enter**.
- 2 Click on **Frame Network Addresses**.

The screenshot shows the K-FRAME Web Access interface. At the top left is the Grass Valley logo (a stylized 'GV' in a purple circle) with the text 'grass valley' and 'A BELDEN BRAND' below it. To the right of the logo is the title 'K-FRAME Web Access'. Below the header is a purple horizontal bar. The main content area is dark grey. On the left is a vertical sidebar with several menu items: 'Software Versions', 'Frame Status', 'Frame Message Log', 'Frame Network Address' (which is highlighted), 'Frame Date & Time', 'Frame Description', 'SNMP Configuration', 'IP Video Status', and 'IP Video Statistics'. The main content area is titled 'Frame Network Address' and contains a section for 'Facility LAN'. This section has three input fields: 'IP Address' with the value '10.16.17.90', 'Subnet Mask' with the value '255.255.248.0', and 'Gateway IP' with the value '10.16.16.1'. Below these fields is a 'Save New Settings' button. A note below the button reads: 'Note: After changing IP addresses, you must reboot the frame for them to take effect'. Below the note is a red 'Caution' icon followed by the text: 'Caution Changing a network address to an incorrect value may render the system inoperable'.

- 3 Under Facility LAN, type in the new IP Address (and subnet mask and gateway if needed). Make sure you enter the correct number exactly. A typing error can make the frame inaccessible over the network, since you need to know its IP address for use with the Web browser.
- 4 Click on the **Save New Settings** button.
- 5 Reset the device.

Result: The device will boot up with the new IP Address.

When a Video Processor Frame IP Address has been changed, communications will no longer occur with any K-Frame system devices that are configured to use the old frame IP

Address. You will need to go to each device and change the address they use to communicate with the Video Processor Frame.

## Set the IP Video Configuration for SFP Gateway and Subnet Masks

IP Video Configuration is supported from the K-Frame Web Access page. IP Gateway and Subnet Mask Addresses can be set for each SFP (Small Form-factor Pluggable) Modular IP/IO port.

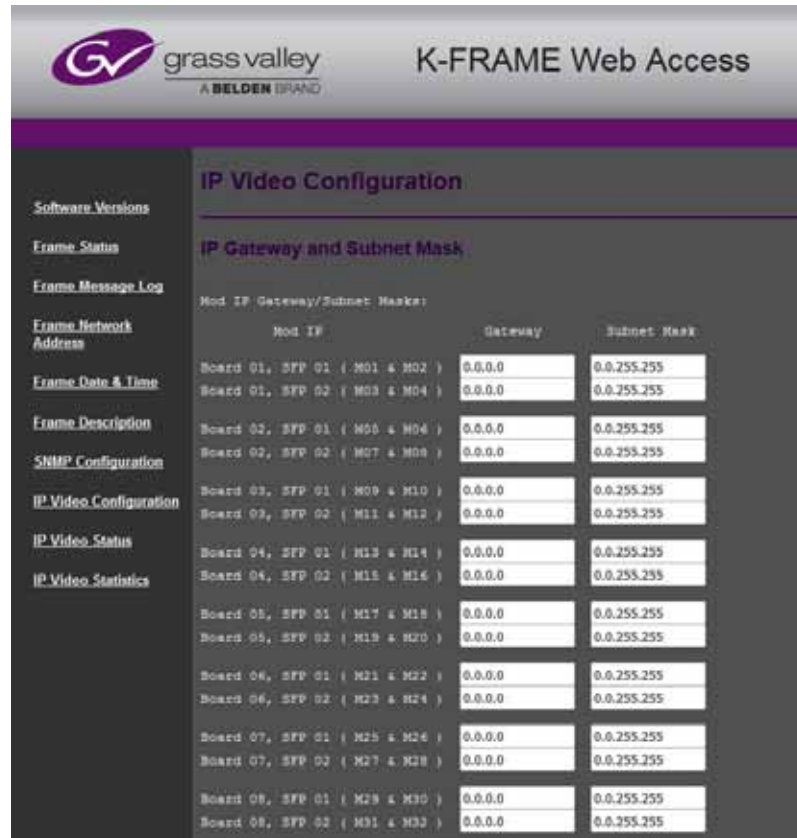

## Changing the Image Store IP Address

The Image Store IP address can be changed using the Video Processor Frame web page (see the *K-Frame Installation & Service Manual*).

## Changing Control Panel IP Addresses

A K-Frame's Control Panel's IP address can be changed using various methods:

- K-Frame Switcher Installer program.
- the K-Frame Control Panel Web page, or
- the Grass Valley NetConfig application.

## Changing the Kayenne or Karrera Menu Panel IP Address

Set the K-Frame Menu Panel IP addresses using the Windows XP interface. You may use the touch screen to access the Windows settings but you will need to use a mouse and keyboard connected to the Menu Panel for entering the IP address values. To set the Menu Panel address:

- 1 Select **Eng Setup, Status**, then select the **Minimize Menu** button. This will take you to the Windows desktop.
- 2 Select **Start, Settings, Network Connection, Local Area Connection, Properties**, and follow the standard Windows IP address setting procedure.

## 32-Crosspoint Remote Aux Panel IP Address

The default IP addresses of Remote Aux Panels are set to at the factory before shipment will not work with a K-Frame system whose other components are set to defaults. Typically, systems are equipped with more than one Remote Aux Panel. If more than one Remote Aux Panel will be used on your system, you will need to change each panels' IP addresses so none are duplicated, and this must be done before you connect them to the network. This will require a mouse and keyboard connected to a PC disconnected from the network.

Check with your network administrator to learn what IP addresses should be used at your facility.

### Setting the IP Address

A PC equipped with an Ethernet interface and a web browser is required to change Remote Aux Panel IP addresses.

- 1 With the PC disconnected from all facility networks, connect the PC's Ethernet port directly to the Remote Aux Panel.

---

**Note:** A crossover Ethernet cable (Tx/Rx pair crossed) is needed when connecting a PC directly to the Remote Aux Panel without a hub intermediary.

---

- 2 Start the web browser, enter the default IP address (192.168.1.2) in the address field, and press **Enter**. If the address is found, a Panel Status screen swill appear.

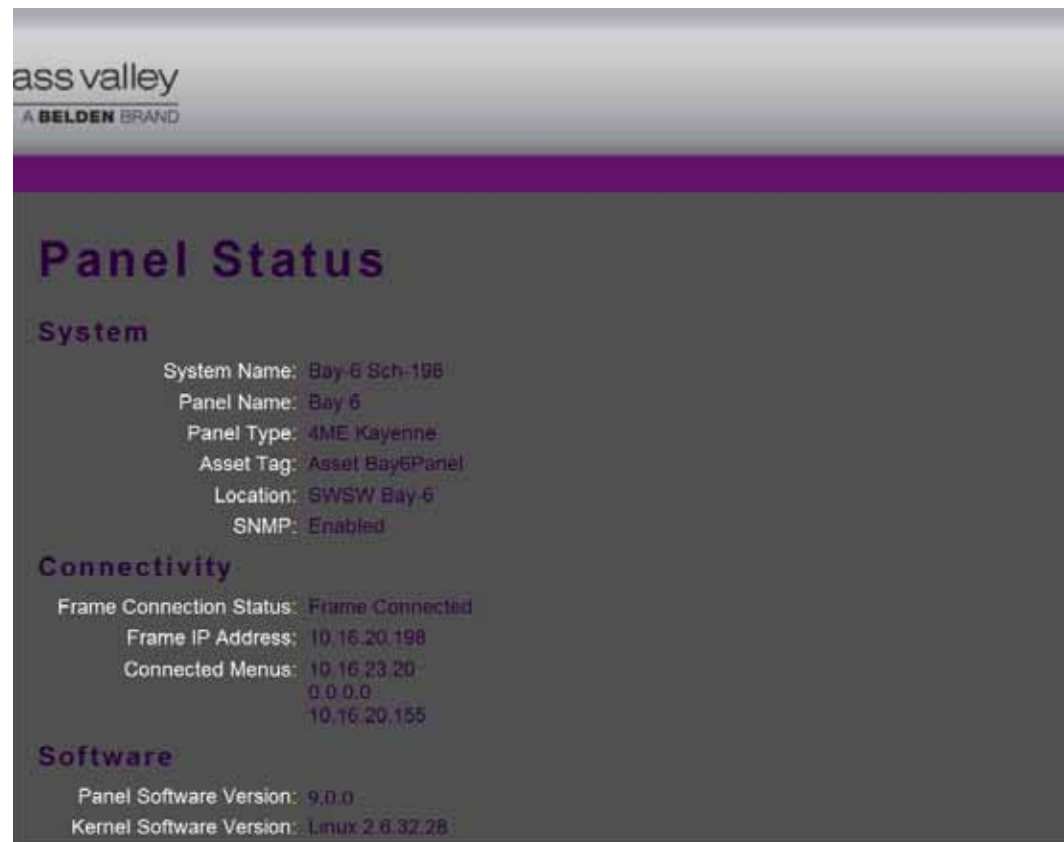

- 3 Click on **Network**. A Network Configuration screen, displaying the factory default settings.

ass valley  
A BELDEN BRAND

### Network Configuration

Panel Name:

### Network Settings

Panel IP Address:   
Subnet Mask:   
Gateway IP:   
Frame IP Address:   
Connected Menus:   
  
  
Panel Ethernet MAC Address:

Note: Changes to the Panel Network settings or Panel Name will cause the Panel to reset

Note: Changes to the Frame IP Address will cause the panel to reconnect to the new Frame without resetting

**CAUTION:** Changing Panel IP address to an incorrect value may render the system inoperable

- Enter the IP addresses and other information appropriate for your system.
  - **Panel Name** is used to name the panel, for user convenience. This field does not affect the operation of the unit.
  - The **Frame IP Address** field is for the K-Frame Video Processor.
- 4 Click on **Apply**. The new IP addresses will be saved and the Remote Aux Panel will reset. You should label the panel with its IP address and keep a record of all IP addresses for future reference.
  - 5 Disconnect the PC, and connect the Remote Aux Panel to the K-Frame system network.
  - 6 Repeat this procedure on all the Remote Aux Panels to be used with your K-Frame system, entering a unique IP address for each Remote Aux Panel.

## Restoring the Default IP Address

You need to know the current IP address of the Remote Aux Panel in order to change it using the Web browser. If a panel's IP address has been changed and its new value not recorded, it will be impossible to change its IP address. You can restore the panel to its factory default address, if necessary, with the following procedure.

- 1 Disconnect the Ethernet cable and the AC power cable from the Remote Aux Panel.
- 2 Reconnect only the AC power cable. The panel will enter a diagnostic mode.
- 3 Push down and hold any panel button. After three seconds panel buttons will light up sequentially, indicating different available diagnostics.

- 4 When three buttons illuminate, release the held button. This places the panel in IP Address reset mode, and one button will be flashing.
- 5 Press the flashing button. This resets the IP address to factory default.

## About the S25/S50 Remote Aux Panel Upgrade

S25 and S50 model Aux panels can be upgraded to become Switcher Remote Aux Panels. The upgrade primarily consists of updating the Aux panel and switcher software, switcher configuration through the menu, and Remote Aux panel configuration through the Web page.

### Switcher Remote Aux Button Functionality

#### Switcher Remote Aux Button Descriptions

Aux Panel	Button	Description
S25	1-25 Source Select	25 Logical Source Select buttons
S50	Top 1-25 Source Select Bottom 1-25 Source Select	50 Logical Source Select buttons

Eight-button group located on right of S25/S50 Aux Panel:

S25/S50	Top 1	M/E 1 Fixed Source
	Top 2	M/E 2 Fixed Source
	Top 3	M/E 3 Fixed Source
	Top 4	Reserved
	Bottom 1	PGM Fixed Source
	Bottom 2	Reserved
	Bottom 3	Source Hold (source bus hold): When on (high tally), the mapped source for the selected source button will not be affected by E-MEM recall.
	Bottom 4	Reserved

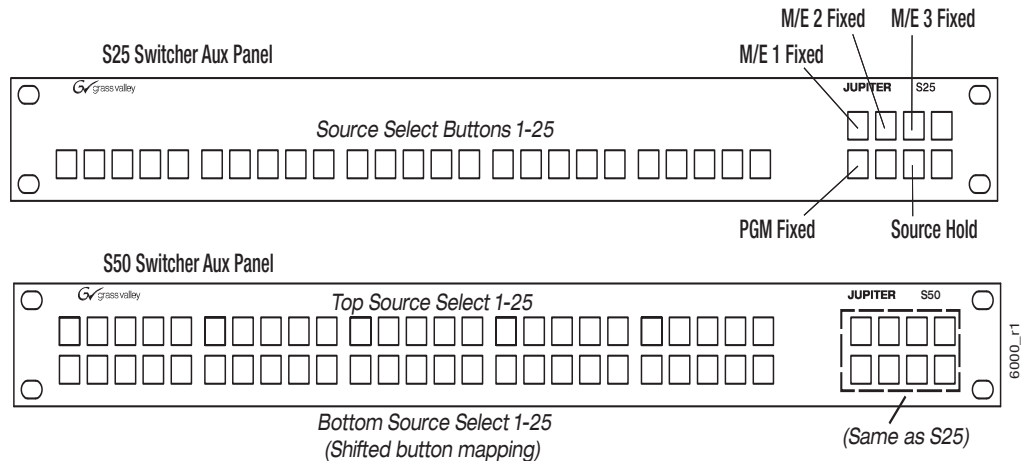

S25/S50 Switcher Remote Aux Panel Buttons

## Install New S25/S50 Remote Aux Panel Software

The NetConfig utility is used to install the Aux Panel software.

- 1 Launch the Grass Valley software installer **K-FrameSetup.exe**, located on the GV USB stick or download it at [grassvalley.com](http://grassvalley.com) (see the *K-Frame User Manual*).
- 2 Select NetConfig from the menu buttons, left.
- 3 Select the Load SW button (top-left).
- 4 In the “Select devices to load:” pane, select **Routers, Jupiter**.
- 5 Select the S25 and/or S50 Aux Panels and NetConfig will search for the panel IP Addresses.  
Result: Located Aux Panels of that type are displayed in the list, right.
- 6 Select the check box next to the panels to be updated.
- 7 Select the **Load** button below the list.
- 8 Reboot the Aux Panel to complete the installation.

## Configure the Remote Aux Panel System

Configure the Remote Aux Panel System through the Product Web Access page.

- 1 Enter the Aux Panel IP address into your browser.  
Result: the Product Web Access page for the Aux Panel is displayed.
- 2 Select **Panel System** on the left.
- 3 Set the parameters by entering values into the fields for Panel Device Name, Asset Tag, etc.
- 4 Optionally, Disable S50 auto-shift for the bottom 25 buttons:
  - *Enabled*: Bottom 25 buttons are auto-shifted.

- *Disabled*: 32 buttons starting with the top 25 and the first seven on the bottom, from left to right, can be mapped. Enabling the shift button provides another 32 shifted sources, using the same buttons, for a total of 64 mappable buttons.

- 5 Select the **Do reset**.
- 6 Select **Save New Settings**.

## Configure the Remote Aux Panel Network

Configure the Remote Aux Panel Network through the Product Web Access page.

- 1 Enter the Aux Panel IP address into your browser.  
Result: the Product Web Access page for the Aux Panel is displayed.
- 2 Select **Panel Network** on the left.
- 3 Enter the Ethernet IP Settings.
- 4 Scroll down and select **CPL** as the Connection Type.
- 5 In the LAN Primary Host IP field, enter the switcher IP.
- 6 Select the **Do reset**.
- 7 Select **Save New Settings**.

## Connect the Remote Aux Panel to the Switcher IP Network

The Remote Aux panel connects to the switcher via Ethernet over an IP Network. To connect, add the Remote Aux panel as a switcher node.

- 1 Select Eng Setup, Node Settings, Remote Aux IP Network in the menu.
- 2 In an unused row, select and enter values for the Aux Panel Name, Remote Aux IP Address, and Suite number (Suite 1 or Suite 2) using the pop-up keypads displayed when you select each data pad.
- 3 Under Aux Panel Type, select the Single data pad as the delegation.  
Result: Status indicator LED turns green when connected.

## Delegate Control of a Switcher Aux Bus to the Remote Aux Panel

Map the switcher Logical Aux Bus for Remote Aux panel control.

- 1 Select Eng Setup, Node Settings, Remote Aux Logical Map in the menu.
- 2 Select the remote aux panel under the Remote Aux Panel Name scrolling list on the left.
- 3 Select a Logical Aux Bus.  
Result: The switcher Aux Bus sources can be mapped to and controlled by the Remote Aux panel.

## Map Switcher Sources to Remote Aux Bus Buttons

Map switcher sources to the physical source select buttons on the Remote Aux panel. The first 25 Buttons will be mapped for the S25. For the S50, the first 25 Unshifted and first 25 Shifted button mappings will be used for a total of 50. However, if the auto-shift feature has been disabled, 32 unshifted and 32 shifted sources can be mapped (top 25, first seven on the bottom from left to right).



- 1 Select Eng Setup, Node Settings, Remote Aux Button Map in the menu.
- 2 Select the remote aux panel under the Remote Aux Panel Name scrolling list on the left.
- 3 Select a source from the Logical Sources or Fixed Sources columns (right) for your Remote Aux source select buttons 1-25 in the Unshift column.
- 4 For the S50 model, select sources for buttons 1-25 in the Shift column.
- 5 If the auto-shift for the bottom 25 source selection is disabled, select up to 32 shifted sources.

Result: The mapped switcher Aux Bus sources can be controlled by the Remote Aux panel.

## About Modular 10GigE IP I/O Address and Port Configuration

You can configure 10GigE IP I/O channels to transmit and/or receive video signals over IP. Selecting a data pad displays a pop-up pane or key pad to make selections or enter parameters.

No settings are committed to the switcher system until the **Apply Settings** button is selected.

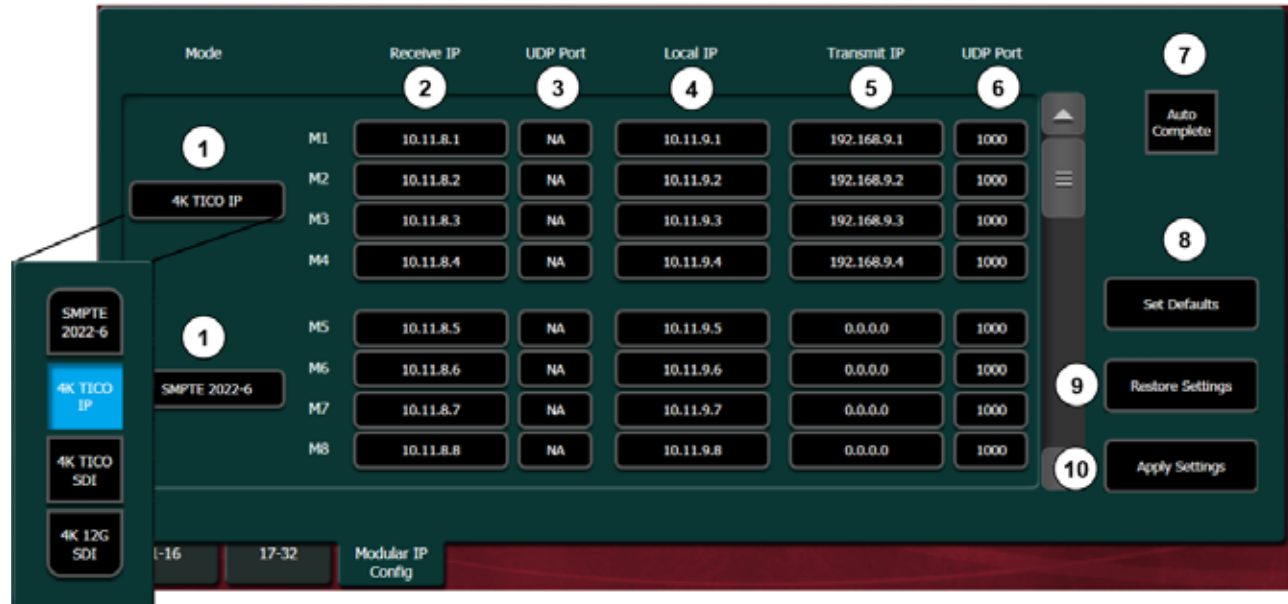

- 1 **Mode:** Mode button selections apply to all four channels on a Modular I/O IP board (for example M1 through M4).
- 2 **Receive IP:** Receive transmission from external devices sending to this IP Address; select dot (.), Enter to insert "Use Local IP" Address.
- 3 **Receive UDP Port:** Setting the UDP port will filter incoming signals by UDP Port. Select dot (.), Enter to insert the default, N/A which disables filtering on the UDP Port numbers.
- 4 **Local IP:** IP address for the local device.
- 5 **Transmit IP:** Target IP address. Set to send a signal. Setting the Transmit IP to 0.0.0.0 disables the transmission. Match the Transmit IP Address with the IP Address of the device receiving this transmission.
- 6 **Transmit UDP Port:** Set transport UDP Port number. Select dot (.), Enter to insert the default, 1000. Match the Transport UDP Port number to the device receiving this transmission.
- 7 **Auto Complete:** Auto-enters IP addresses sequentially, from the selection downward in the selected column.
- 8 **Set Defaults:** Sets the IP Addresses and UDP Port Numbers to the default settings.
- 9 **Restore Settings:** Restores settings before changes (will not restore after Apply Settings has been selected).
- 10 **Apply Settings:** Commit all changes to the switcher.

*Modular IP Config Menu Tab Features*

## 10GigE Modular I/O Modes

4K modes require the switcher system to operate in 1080pA mode.

### Modular IP I/O Modes

Mode Name	Descriptions
SMPTE 2022-6	The default, four signals split between two I/O
4K TICO IP <sup>a</sup>	4K, two-sample interleave quad link signals compressed and sent over Ethernet, then uncompressed to two-sample interleave, quad link signals at the receiver
4K TICO SDI	4K, two-sample interleave quad link signals compressed and sent over 3G SDI, then uncompressed to two-sample interleave, quad link signals at the receiver
4K 12G SDI	4K, two-sample interleave quad link signals sent uncompressed over 12G SDI, then converted to two-sample interleave, quad link signals at the receiver

a. Only the first input of the SFP Card is used to receive 4K TICO signal. On the output, the 4K TICO is on the first and third outputs; the second and fourth outputs carry an uncompressed 1080p Level A monitor signal.

## Transmit IP Addresses and UDP Ports

To transmit over IP, you must set the Transmit IP address. The Transmit IP Address and the UDP Port Address must match. You can use the default UDP port setting of 1000 or change it to fit your workflow. Setting the UDP Port number allows you to send two video streams with different UDP port numbers to the same IP address.

Multicast signals can be transmitted from and to the switcher by setting the first octet of the address to between 234 and 239 (see [Configure a 10GigE IP I/O Multicast Video Signal](#)). Ethernet switches enable an IGMP Query Server in order to pass Multicast signals.

## Local IP Addresses

The Local IP Address is used for two purposes:

- To transmit the Local IP Address from the switcher system so other devices can identify where data is being transmitted from, and
- As the Receive IP Address so devices can send data to the switcher system.

## Receive IP Addresses and UDP Ports

For the Receive IP address channels, you can either use the default presets or change them to fit your preferences, including the Local IP. The default port setting for Receive IP is N/A. The N/A setting means signals from an IP address with any port setting is available to the configured device. Setting the UDP Port number allows you to filter signals, for example signals from two or more channels using the same IP address.

## Configure 10GigE Modular I/O Mode

Modular I/O Mode selection in the Modular IP Config menu tab, is applied to each of the four input/output ports for that I/O board (for example M1 through M4). Selection mode buttons for SMPTE 2022-6, 4K TICO, and SDI are provided (see [About Modular 10GigE IP I/O Address and Port Configuration](#)).

---

**Note:** 4K modes require the switcher system to operate in 1080pA mode.

---

- 1 In the Eng Setup, Mod I/O, Modular IP Config tab, select the Mode data pad of the four I/O channels you wish to configure.
- 2 Select a mode from the Mode button pop-up pane.
- 3 Select the **Apply Settings** button.

## Configure 10GigE IP I/O Transmit IP Addresses and UDP Ports

To transmit a video signal from a Switcher IP I/O Module channel, the Transmit IP address must be set; the factory default is 0.0.0.0. The default port assignment is 1000.

- 1 In the Eng Setup, Mod I/O, Modular IP Config switcher menu tab, select the Transmit IP Address data pad for the IP I/O channel (for example M1), enter the IP address in the pop-up keypad, and select **Enter**.
- 2 To set the Transmit IP UDP Port (see [About Modular 10GigE IP I/O Address and Port Configuration](#)), select the data pad for the channel, enter a port number, and select **Enter**.
- 3 Select the **Apply Settings** button.

## Configure 10GigE IP I/O Receive IP Addresses and UDP Ports

To receive signals over IP, you must set the Local IP address so the signal is available to your device. For the Receive IP address channels, you can either use the factory presets or change them to fit your preferences, including the Local IP. The default port setting for Receive IP is N/A (see [Receive IP Addresses and UDP Ports](#))

- 1 In the Eng Setup, Mod I/O, Modular IP Config switcher menu tab, select the Local IP data pad for the I/O IP channel you wish to configure, enter the IP address for your device, and select **Enter**.
- 2 Select the Receive IP Address data pad for the Modular I/O IP channel (for example M1), enter the IP address in the pop-up keypad or select dot (.) to select the Local IP address, and select **Enter**.
- 3 To set the Receive IP UDP Port, select the UDP Port data pad for the channel, enter a port number, and select **Enter**.
- 4 Select the **Apply Settings** button.

## Configure a 10GigE IP I/O Multicast Video Signal

IP addresses for Multicast must use 224 through 239 as the first octet in the address. A Multicast signal can then be sent to an Ethernet switch or received to your local device.

**Note:** Ethernet switches must have the IGMP Query Server enabled to receive a Multicast signal.



- 1 In the Eng Setup, Mod I/O, Modular IP Config switcher menu tab, select the Receive IP or Transmit IP data pad (see [About Modular 10GigE IP I/O Address and Port Configuration](#)) for the IP I/O channel you wish to configure, enter the Multicast IP address, and select **Enter**.
- 2 To set an IP UDP Port, select the UDP Port data pad for the channel, enter a port number, and select **Enter**.
- 3 Select the **Apply Settings** button.

## Registering K-Frame System Nodes

When IP addresses have been changed on K-Frame system components, or new components are added, the Video Processor Frame needs to know what new addresses it will use to communicate with those components. This is accomplished by registering those addresses with the Frame using the GV Switcher menu application Node Settings menus.

### Kayenne and Karrera Menu Panel Registration

Registering the K-Frame Menu Panel (or PC running the GV Switcher menu application) with the Frame was described earlier (see [Establishing Menu to Frame Communication](#)). The GV Switcher menu application needs to be in communication with the Video Processor Frame before other nodes can be registered.

## K-Frame Control Panel Registration

- 1 Touch **Eng Setup, Node Settings, Control Surfaces**.
- 2 Touch an available set of buttons and enter a Node Name and the IP address of the Control Panel.
- 3 You can assign the component to a suite and control surface now if you wish, but it is recommended to initially configure your K-Frame system as a single suite. Later, you can modify the configuration for multi-suite operation.
- 4 If you want that Control Panel button DPOPs (double press open button) to affect this Menu Panel, touch **Frame Suite Nodes & ID** and enter the IP address of that Control Panel in the Track DPOPs from Panel ID field.
- 5 Reset the Control Panel:
  - a **Kayenne**—On the Control Panel Multi-Function Module access the Home menu, then press **Panel, IP, Boot** and press **Yes**.
  - b **Karrera**—In the Master E-MEM Area, select the **Menu** hard button, **Page** hard button, then in the LED, select **IP Addresses, Panel Boot**.
  - c **GV Korona**—Select the **Status** menu button, then select **Closedown Menu Computer** and select **Restart** from the Windows pull-down menu.

---

CAUTION: Selecting Shutdown in the Windows pull-down will require you to power cycle the GV Korona Control Panel.

---

## Remote Aux Panel Registration

---

Note: Do not confuse the Kayenne or Karrera Local Aux Panels, which are considered a Control Panel Stripes, with Remote Aux Panels, which are small panels used to change Aux Bus sources from a different location. The Local Aux Panel Stripe is not configured with the following menus.

---

- 1 Select **Eng Setup, Node Settings, Remote Aux IP Network** in the GV switcher menu.



- 2 Select an available set of buttons and enter an Aux Panel Name and IP address of each Aux Panel.
- 3 Identify the type of Remote Aux Panel (Single or Multi- Destination).
- 4 You can assign the component to a suite and control surface now if you wish, but it is recommended to initially configure your K-Frame system as a single suite. Later, you can modify the configuration for multi-suite operation.

## Control Panel Brightness Adjustment

The Control Panel is calibrated at the factory for even brightness and color balance. Individual panel area illumination levels cannot be adjusted in the field. However, the relative brightness of button tally, source name displays, and text displays can be adjusted on a global basis to meet individual requirements (for example, to accommodate varying ambient room lighting levels).

- 1 Access the K-Frame Panel Web page, by entering its IP address in a Web browser, then selecting **Configuration**.



- 2 Enter the desired values for OLED, Text Display, High Tally, and Low Tally, and then select **Apply**.

**IMPORTANT:** To extend the life of display illumination hardware (in particular the OLEDs), the Control Panel automatically enters a panel saver state when its controls have not been touched for a specified time (ranging from 10 to 30 minutes). In the panel saver state all the Control Panel buttons and displays go dark, except the **Key 1** through **Key 6** and **Key Prior** buttons are illuminated blue and cycle. Touching any button or control on the Control Panel exits the panel saver state.

## Engineering Setups

K-Frame inputs and outputs are connected to the rear of the Video Processor Frame. These video signals need to be configured to your facility's requirements. Engineering Setups defines K-Frame system component functionality and how it is cabled into a facility. Engineering setups are intended to be used and maintained by technical staff, and can be loaded and saved to disk.

The Engineering Setup menus are accessed by touching the **Eng Setup** menu button at the bottom of the screen, and then selecting the appropriate Menu Category button.

## Source Definition Inputs

Source definition tells the system which physical inputs or internal signals to use when a particular external (only) source is selected. The source definition, denoted by an



Engineering ID number, specifies the signals involved, how to process that signal, and what external devices, if any, are associated with that source. Each K-Frame Video Processor has one source definition set, shared by all users of that system (both control surfaces in both suites).

### Standard K-Frame Source Definition Inputs

Inputs					Modular Inputs			
1-32	33-64	65-96	97-128	129-160	161-164	169-172	177-180	185-188
					165-168	173-176	181-184	189-192

### Compact K-Frame Source Definition Inputs

Inputs					Modular Inputs			
1-32	33-64	N/A	N/A	N/A	161-164	169-172	N/A	N/A
					165-168	173-176	N/A	N/A

## Change Direct Source Definition

- 1 Select **Eng Setup, Source Definition** in the menu.
- 2 Select a Source located on left side of the screen (it is a vertical scrolling list).
- 3 Select the **Engineering Name** data pad to name the source using the pop up alphanumeric keypad or standard keyboard. Up to 30 characters can be entered, but shorter names are recommended.
- 4 Select the **Video Input** data pad to enter or scroll to the input number of the connector the source will use for video. The change is immediate and can be viewed on a connected monitor.
- 5 If the source includes a key signal, select **Linear** key with the lower touch buttons. Then select the **Key Input** data pad and enter to the input number of the connector the source will use for the key.
- 6 For Chroma keys you can select either **Linear** or **No Key**. Chroma keys always use the video signal for keying, ignoring any separate key signal.
- 7 If desired, define **Clip High** and **Clip Low** values (used when a fixed linear key is selected for that source) with the labeled soft knobs and data pads.

## Source Naming Background Information

Facility engineers need to know the exact routing of all the video signals connecting all the devices they are responsible for. These engineers need to be able to identify video signals in a way that will help them connect devices properly. Production personnel, on the other hand, are interested in the content they work with for their shows, and are generally not concerned about which individual device or routing path is used to make those signals available. They just need a way to identify the content and access it when they need it. To support these differing needs, two source naming mechanisms are available on K-Frame systems.

## Engineering Names, Eng IDs, and Logical IDs

Engineering names are intended to identify a source as it applies to a specific facility. In a truck, for example, cameras may be hard wired to the production switcher and might be given Engineering names 1, 2, and 3. Names like Patch 14 or Rtr 5 may be used for inputs that are patched or routed. Engineering names are entered in the Eng Setup Source Definition menu, as described above. Engineering source IDs are numeric only, and are available on data pads and scroll knobs for quick selection. The K-Frame system also has logical IDs, that can be used for source patching, as explained later.

## Alternative Source Names

Alternative names can be assigned to sources for the convenience of production personnel. For example, you may give the cameras menu names that include the operator (C1 Bob, C2 Phil, and C3 Bill), but remove the operator names from the OLED names to show C1, C2, and C3 in larger characters. These alternative names are entered in the Source Patch menu.

The User Setups, Suite Prefs, Source Patch menu (Figure ) has three editable columns for defining up to three alternative names:

A **Panel Name** is limited to four characters, to fit the space available on the Control Panel's Transition Module. This name is only displayed on the Control Panel.

An **OLED Name** appears only on the Source Name Displays on the Control Panel. Up to eight characters are displayed.

A **Menu Name** is limited to eight characters, and appears on all the GV Switcher menu application screens except Engineering Setup menus, which always display engineering IDs or names.

## Multiple Suites and Source Names

Different sets of these alternative source names are defined for each K-Frame suite. Ensure the GV Switcher menu application you are using is logged into the correct suite (**Eng Setup**, **Eng Login**). The same set of engineering names will be used by both K-Frame suites, however.

## Name Display Hierarchy

If a source's engineering name is left blank, the Eng ID number will be used. If no alternative names are defined for that source, then that Eng ID number will appear on all the K-Frame system displays.

If an engineering name has been entered then the engineering name will be displayed on all the K-Frame system displays, including menus. Engineering names will be truncated to the character limits of the display, starting with the first character.

For alternative names entered in the User Setups, Suite Prefs, Source Patch menu, the following rules apply:

For the three editable columns: **Panel Name**, **OLED Name**, and **Menu Name**, if any of the three are left blank for that source, the first name to the left appears in that display on the system (if all three are left blank, the name in the Eng. Source Column is displayed). For example, if an alternative name is entered in the OLED Name column for a source and the other two columns remain blank, the Menu Name takes the OLED Name (OLED Name being

first to the left of the Menu Name) but the Panel Name takes the Eng. Source column's name (first name to its left). If names are entered in all three alternative name columns, each area of the system displays the name entered in each column of the Source Patch menu.

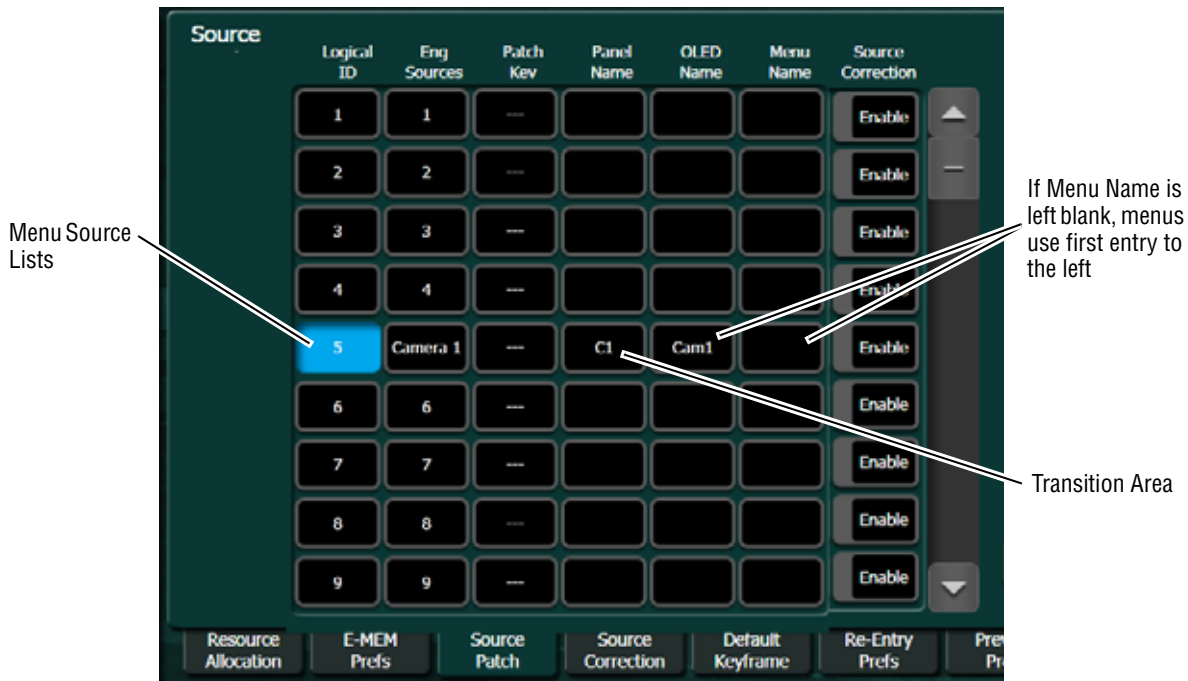

It a good practice to create the least number of names possible. This ensures consistency in the various displays and reduces the time needed to enter and edit the names. If you can create short engineering names that work for both the production staff and engineering, complete naming consistency is assured. However, this level of simplicity is probably only feasible at a fixed installation where all the shows use the same source names. When multiple names are created, try to keep the first four characters unique, and make different names for the same source similar for ease of recognition.

### Fixed Sources

Additional, fixed internal sources exist on a K-Frame system. These internal sources do not have user accessible Engineering IDs and are not displayed on the Eng Setup Source Definition menu.

#### Fixed Internal K-Frame Sources

Area	Signals	Source Patch Eng. Source Names
ME 1, 2, 3, 4, Pgm	A, B, C, D, Preview A, Preview C, and ME Viewer (pM) outputs	M1 A, M1 B, M1 C, M1 D, M1 pA, M1 pC, M1 pM same for M2 - M4, Pg A, Pg B, Pg C, Pg D, Pg pA, Pg pC, Pg pM
eDPM	Video Out A, C	eDA, eDC
	Key Out A, B, C, D	eDAk, eDCk

### Fixed Internal K-Frame Sources

Area	Signals	Source Patch Eng. Source Names
internally generated signals	Test 1, Test 2	Test
	Black, Black Key	Blk
	White	Wht
	Background 1	BG 1
	Background 2	BG 2
Image Store	Video Out 1 - 10	IS 1A - IS 10A
	Key Out 1-10	IS 1B - IS 10B

These fixed sources are accessible via:

- User Setups, Suite Prefs, Source Patch menu
- User Setups, Panel Prefs, Button Mapping menu
- Eng Setup, Outputs menu

## Source Patch Feature

The K-Frame system provides a way to map engineering source IDs to logical IDs, using the Source Patch feature. By default this mapping is one-to-one, but this feature can be used to quickly set up production elements for use in a different facility. For example, a show's effects, DDR clips, and taped material may have been built in one production truck with one set of devices, but the next show is scheduled for a different truck. Previously, to use effects in the other truck the Technical Director (TD) would need to edit the engineering source definitions in the new truck so they exactly matched the old truck. By remapping the engineering sources of the devices in the new truck to the logical sources used to build the effects, all the effects can be used without having to edit them. Source Patching can also be used to quickly swap out a defective device during a show without having to reconfigure the engineering sources. In this case logical names seen by the production personnel would be identical for that content, even though the actual device playing the material changed.

---

**Note:** Source Patching is the bridge between engineering sources and logical sources. Both TD and EIC should make reference to this menu when resolving source issues. The mechanism is similar in concept to a physical patch panel. Effects and all source selections are based on logical sources. Tally and associations with external devices are based on engineering sources.

---

After sources have been defined they can be mapped to K-Frame system Control Panel buttons. The Button Mapping menu (accessed by touching **User Setups, Panel Prefs, Button Mapping**) is used to map the sources associated with each source selection button. Refer to the separate *K-Frame User Manual* for specific button mapping instructions.

## Output Assignments

Any K-Frame outputs can be assigned as fixed outputs, which includes any ME, Image Store, or eDPM outputs. In addition, any Logical input source can be assigned to any output.

### Source Definition Outputs

#### Standard K-Frame Source Definition Inputs

Outputs				Modular Outputs			
1-16	17-32	33-48	49-64	65-68	73-76	81-84	89-92
				69-72	77-80	85-88	93-96

#### Compact K-Frame Source Definition Outputs

Outputs				Modular Outputs			
1-16	17-32	N/A	N/A	65-68	73-76	N/A	N/A
				69-72	77-80	N/A	N/A

### Default Output Assignments

Default output assignments for K-Frame systems are one-to-one with the Aux buses, beginning with Aux 1.

## Change Output Assignments

The Outputs menu is used to change the K-Frame system output assignments. The current output assignments can be viewed in this menu. The scrolling list of data pads along the left side of the screen shows the currently assigned output for each listed module output connector. The right side of the menu shows the items available for assignment to that output connector. Different choices appear, depending on the **Output Type** selected, as shown below.

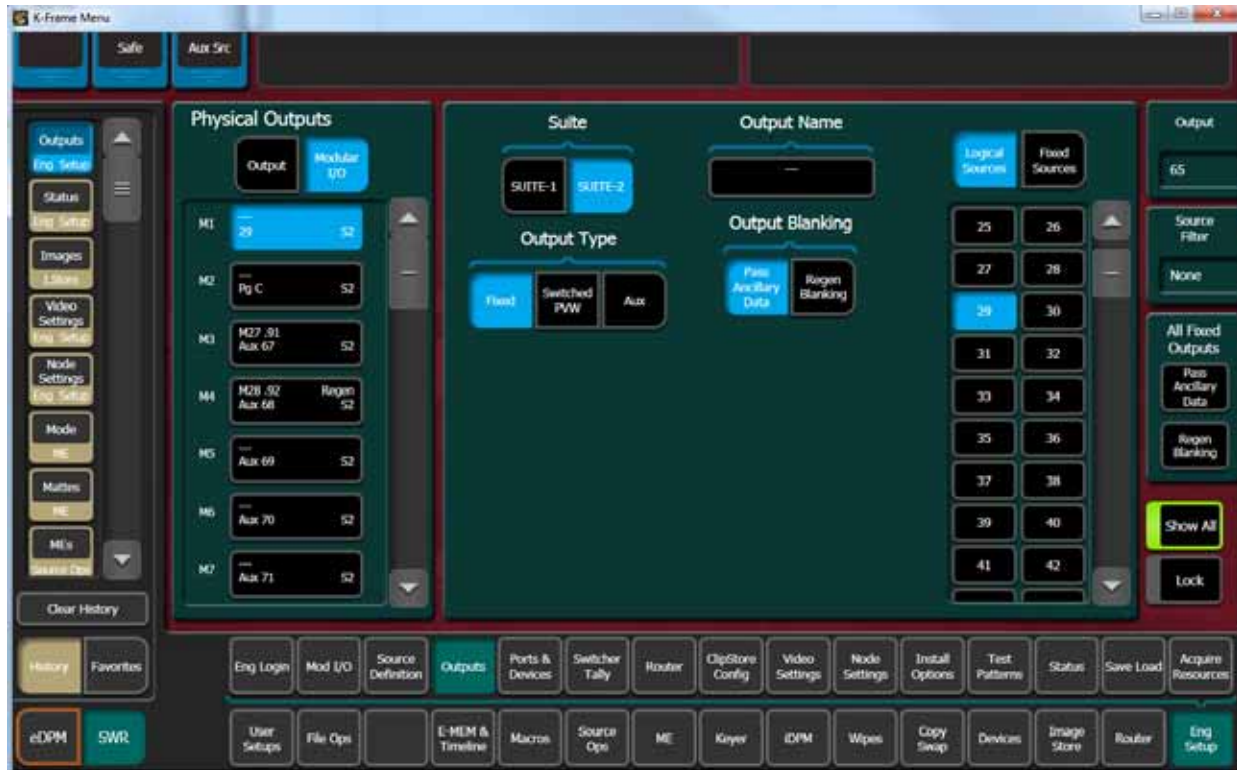

- 1 Select **Eng Setup, Outputs** in the menu.
- 2 Select an output data pad from the left scrolling list to select it and display information for that output connector.
- 3 Select the appropriate Output Type:
  - a **Fixed** if the output is to be dedicated. Later you will be able to select from either Logical Sources or Fixed Sources for that output.
  - b **Switched PVW** if the output will be used for switched preview. Switched preview can be assigned to multiple outputs.
  - c **Aux** if the output will be an Aux bus.

The **Suite 1** and **Suite 2** buttons are used to assign the currently selected output to a suite. The default setting is **Suite 1**.

- 4 Select an output connector from the list on the right. The change is immediate and can be viewed on a connected monitor. (Switched Preview mode does not offer any output sources).
- 5 If desired, select the **Output Name** data pad to change the name of the output using the pop up alphanumeric keypad or standard keyboard. This name appears on the data pad of the scrolling list on the left. Up to 12 characters can be entered.

## Configuring Aux Buses

Aux buses can be used to send dynamically selected sources to an output. Aux bus sources are selected using the Local Aux panel, delegating an ME for Aux Bus control, or using Remote Aux Panels delegated to control that Aux bus.

The number of Aux buses on a K-Frame system varies, depending on how the physical outputs have been mapped. Any output that is not configured as Fixed or Switched Preview is available for use as an Aux bus.

### Video Only Aux Bus

When the **Aux Bus Pair** button is not selected, the Aux bus is configured as a single video-only output.

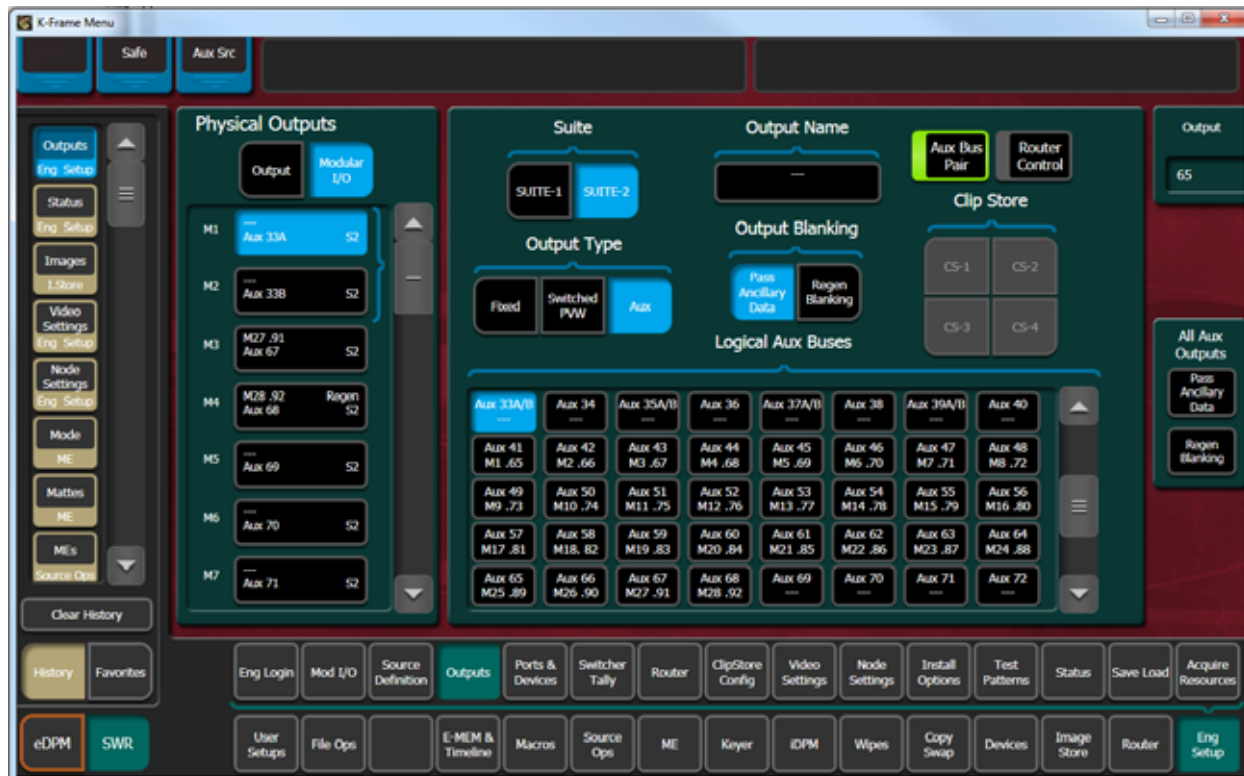

### Aux Bus Pairs

Selecting the **Aux Bus Pair** button configures the Aux Bus as an Aux Pair.



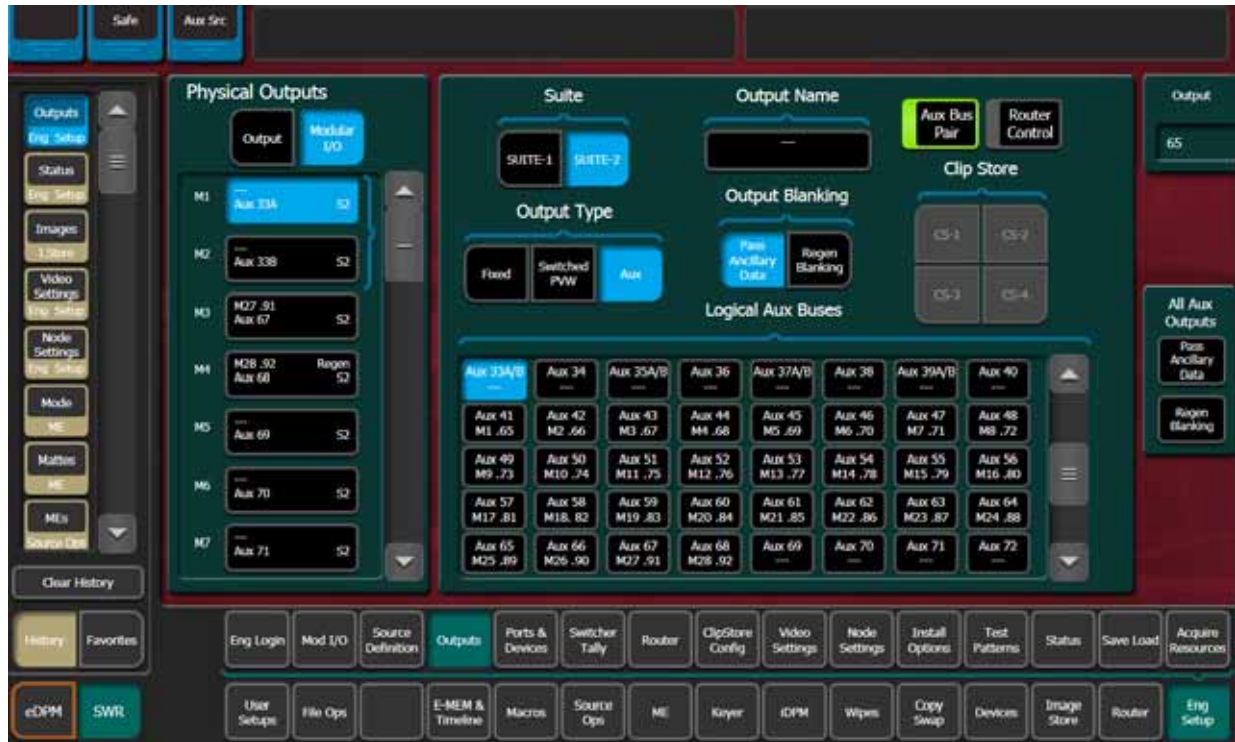

Aux Pairs are two physical Aux Buses that have been configured to send a video and associated key (or another video) signal. Pairing of the video and key signal to be used on the Aux bus is defined in the Sources menu as explained earlier. Aux pairs are indicated on the menu with a bracket beside the two connector buttons. The Aux Bus pairs are also identified with A and B letter indicators. The Aux A signal is always a video signal.

## About Passing/Blanking Ancillary Data for Individual Outputs

ME Blanking allows you to either pass all ancillary data or regenerate blanking for MEs; no audio, subtitles, closed captioning, etc. (in the Eng Setup, Video Settings menu). However, you may want to configure blanking for individual outputs for external devices or other specific uses. Output Blanking is provided in the Eng Setup, Outputs menu to allow this specialized control.

You can also choose to pass ancillary data or regenerate blanking for all Aux outputs or all Fixed outputs in the Outputs menu. For example, if you selected All Aux Outputs to Pass Ancillary Data in the Outputs menu, you could then set individual aux outputs to Regenerate Blanking. This allows fast configuration of a large number of outputs.

## Configure Aux Output Blanking

Configure Aux Output Blanking for all or individual Aux outputs to pass or blank ancillary data in the Eng Setup, Outputs menu.

- 1 In the Eng Setup, Outputs menu, select either **Output** or **Modular I/O**.



- 2 Select an Aux output from the Physical Outputs scrolling list or select **Aux** in the Output Type pane to display the Aux Outputs menu.
- 3 Result: The Logical Aux Bus selection pane is displayed (center) along with other Aux output parameter functions.
- 4 In the All Aux Outputs pane (right), select either the **Pass Ancillary Data** or **Regen Blanking** button to configure all Aux outputs.  
With all outputs set to pass or blank ancillary data, you can change individual outputs to the opposite state.
- 5 Select any output in the Logical Aux Buses scrolling list (center).
- 6 Select either the **Pass Ancillary Data** or **Regen Blanking** buttons under the Output Blanking label to set Output Blanking for an individual output.
- 7 Outputs set to blanking have the word Regen in the upper right of the data pad (all other states are blank), in the Physical Outputs scrolling list.

## Configure Fixed Output Blanking

Configure Fixed Output Blanking for all or individual Fixed outputs to pass or blank ancillary data in the Eng Setup, Outputs menu.

- 1 In the Eng Setup, Outputs menu, select either **Output** or **Modular I/O**.
- 2 Select a Fixed output from the Physical Outputs scrolling list or select **Fixed** in the Output Type pane to display the Fixed Outputs menu.
- 3 Result: The Logical Sources/ Fixed Sources scrolling list is displayed (right) along with other Fixed output parameter functions.
- 4 In the All Aux Outputs pane (right), select either the **Pass Ancillary Data** or **Regen Blanking** button to configure all Aux outputs.  
With all outputs set to pass or blank ancillary data, you can change individual outputs to the opposite state (see [About Passing/Blanking Ancillary Data for Individual Outputs](#)).
- 5 Select any output in the Logical Aux Buses scrolling list (center).
- 6 Select either the **Pass Ancillary Data** or **Regen Blanking** buttons under the Output Blanking label to set Output Blanking for an individual output.

Outputs set to blanking have the word Regen in the upper right of the data pad (all other states are blank), in the Physical Outputs scrolling list.

## ME Viewer

The K-Frame ME Viewer optional feature provides a special source from each ME that can be used to display multiple ME signals on a single monitor. Each ME has a fixed source named **(ME) pM** (ME = 1-4 or Pg). This source can be assigned one of six multiple signal arrangements, in User Setups/Suite Prefs. Assigning this source to a physical output connector permits viewing that arrangement of signals on a monitor.

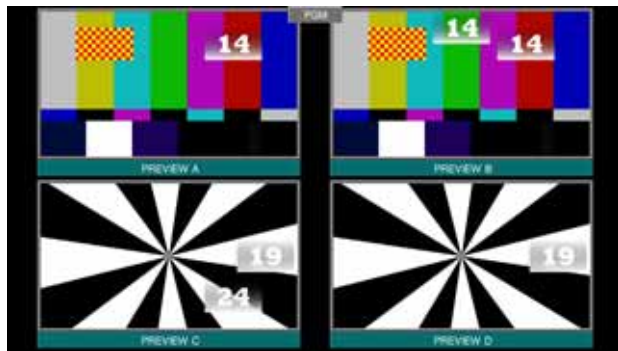

Previews



Programs



Previews Programs



Primary Secondary Keys



Programs Previews  
 Examples of ME Viewer Displays



Primary Previews Programs Keys

## Switcher Relay Tally Configuration

The Switcher Tally menus are used to configure tally system relays. These menus include multiple relay tally calculators, three different relay tally calculation methods, and user assignment of tally relays. The results of the relay tally calculators are applied to the tally relays on the GPI/Relay Tally connectors on the rear of the K-Frame Video Processor. Those relays can control external relay tally lights. The Switcher Relay Tally menus also allow the user to map Engineering Sources to the tally relays. Up to 96 tally relay outputs are available

on a K-Frame Video Processor, 24 for each installed Controller or ME board. Relay tally is recalculated and refreshed every field.

---

Note: Relay tally Contribution is an alternative electronically mechanism that can be assigned to a K-Frame Video Processor serial port. Refer to the separate *Grass Valley Switcher Protocols Manual* for technical information.

---

## About Relay Tally Systems

In general, a tally system identifies which sources to the switcher contribute to the final picture at a selected point in the video chain. The identification is communicated by activating relays in the Video Processor Frame. The method by which the sources are determined is called the tally calculation.

The tally calculation begins at a point in the video path and then traces the path of the signals upstream to their original video (and key) sources. The state of the switcher affects tally. For example, tally on a true clean feed only includes sources that contribute to the main output, but tally on a programmable clean feed can include sources that do not contribute to the main output.

When configuring a tally calculation, the user chooses the starting video path point (called a tributary) to trace back to its origin. The main On Air tally video output point is Pgm-Pst PGM A, but Pgm-Pst PGM B, Pgm-Pst C, and Pgm-Pst D are included in case these alternate programmable clean feed outputs have keys (or utility buses) that don't contribute to the PGM A output.

The On Air tally calculations are essential for switcher operation. (One calculator is reserved for On Air.) This tally calculation forms the basis for On Air indication (panel, camera tally lights, etc.), and other functions such as external device Auto Start, Off Air Advance, or router protections. On Air tally calculations normally start at the Pgm-Pst PGM A-D outputs.

User tally calculations can be used for purposes other than On Air tally. These tally calculations still trace the video path up stream from the specified points in the video path, but the starting point does not necessarily have to be a program output. For example, a Look Ahead tally begins at the Pgm-Pst Look Ahead Preview (LAP). When a transition is not in progress the source feeding the PVW is not on air.

The Output tally calculator indicates which sources contribute to designated outputs. For example, an ME Iso tally is a user configured Output tally set up to begin at an ME's PGM A, B, C and D. The tally would indicate what contributes to the ME's program outputs but not anything down stream of it. The tally would be the same whether or not the ME was On Air.

The Look Ahead tally calculator indicates which sources will be on air if a main transition is performed on the selected level. One way this can be used is for a second set of tally lamps on a camera to alert the camera operator that his camera is next to be taken on air. Many control room monitor walls also include a secondary tally indicator for Look Ahead. Look Ahead tributaries do not necessarily leave the switcher as video signals. For example, an ME has four program outputs but only two physical preview outputs. The LAP information for all four program outputs may be included in a tally calculation.

However, if an ME is placed down stream of Pgm-Pst the On Air tally calculation can be configured to start at that ME's program outputs. If this situation is planned, it is

recommended that aux buses be set up to provide the real program outputs for the switcher and the On Air calculation configured using those aux buses as the tributaries.

You can use more than one starting point for tally calculations. Programmable clean feed (FlexiKey) and DoubleTake allow the exclusion of video signals from the ME main output (PGM A) that appear on one of the other program outputs. Include the other program outputs with the ME main output (PGM A) as calculation starting points to tally all the On Air sources.

The Bus Selection tally calculator indicates which sources are selected on a specified set of switcher buses. The tally calculator using this method does not trace tributaries upstream; it only tells what sources contribute to the specified bus(es), even if the source is an ME. For example, a Bus Selection tally calculation could be set up to indicate which source is selected on the Pgm-Pst A bus, permitting audio-follow-video selections to be run by the tally system.

## Switcher Relay Tally Calculator Menus

The Switcher Tally menus are used to select calculators, methods, and levels, name calculators, and assign items to Tributaries.

K-Frame has six independently running tally calculators. For example, the system can calculate On Air tally independently for suite 1 and suite 2, and at the same time can calculate Look Ahead tally, and ME output tallies for three MEs. The first of the tally calculators is reserved for On Air tally calculations for the currently logged in suite (1 or 2). The other four tally calculators can be assigned to either suite 1 or suite 2.

Up to four tributaries can be included as the basis for each tally calculation. For example, multiple program outputs of the PGM/PST bank are typically included in the On Air tally calculation. The final tally source list is a union of the sources found on each of the four tributaries. If aux buses are used as the program outputs of the switcher, up to four aux buses can be the basis of On Air tally calculations. Tally calculations do not require actual outputs, for example, LAP tributaries are virtual and may never leave the ME.

Selecting an **On Air Tally** or **Tally Calc 1-4** tab delegates the menu controls to the selected calculator as shown below.

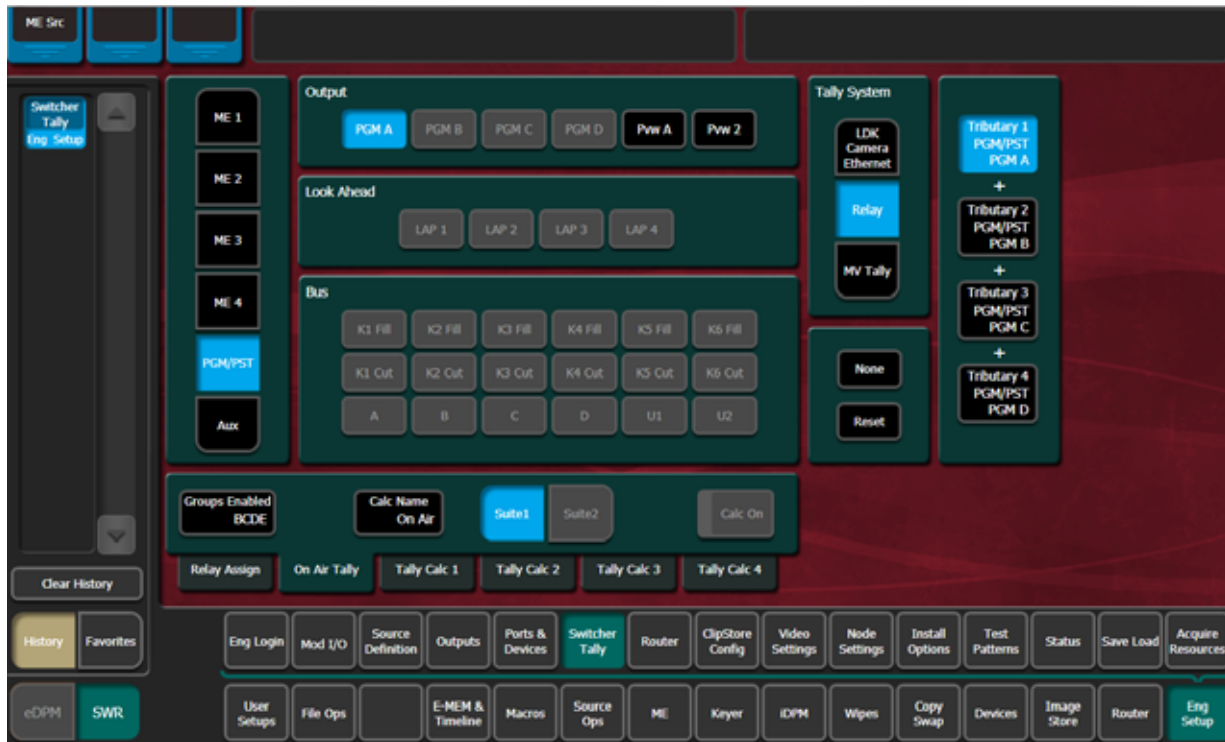

**Calc On** - Turns the delegated Tally Calculator on or off. When on, the **Calculation Enables** button on the separate Relay Assign menu will be activated for that calculator.

**Groups Enabled** - Reports which Tally Groups are currently assigned for that calculator, by group letter (A, B, C, D, corresponding to Tally/GPI connectors 1-4 on the rear of the K-Frame Video Processor). To Enable a Tally Relay Group, it must first be turned on, using the **Calc On** button for that calculator.

The first tally calculator name is fixed to **On Air**. Since the On Air Calculator is restricted the Look Ahead and Bus buttons are disabled (grayed out).

## Creating an On Air Relay Tally Calculator Using MEs or PGM/PST

- 1 If necessary, login to the desired suite (**Eng Setup**, **Eng Login**).
- 2 Select **Eng Setup**, **Switcher Tally**, **On Air Tally** to access the On Air Tally menu. The Suite button for the current suite will be highlighted.
- 3 Select a **Tributary** button on the right.
- 4 Select an **ME** or **PGM/PST** button on the left.
- 5 Select an Output button to assign that output of that ME or PGM/PST to that tributary. The name of the output is displayed on the Tributary button.
- 6 Repeat the steps above for other Tributaries for all the outputs you wish to assign for On Air Tally.
  - Pressing the **None** button clears the assignment for that Tributary.
  - Pressing the **Reset** button clears all the assignments to all the Tributaries.

## Create an On Air Relay Tally Calculator Using Aux Buses

- 1 If necessary, login to the desired suite (**Eng Setup, Eng Login**).
- 2 Select **Eng Setup, Switcher Tally, On Air Tally** to access the On Air Tally menu. The Suite button for the current suite will be highlighted.
- 3 Select a **Tributary** button on the right.
- 4 Select the **Aux** button on the left.
- 5 Select Aux bus button(s) to assign that output of that Aux bus to that tributary. The name of the output is displayed on the Tributary button.
- 6 Repeat the steps above for other Tributaries for all the outputs you wish to assign for On Air Tally.
  - Pressing the **None** button clears the assignment for that Tributary.
  - Pressing the **Reset** button clears all the assignments to all the Tributaries.

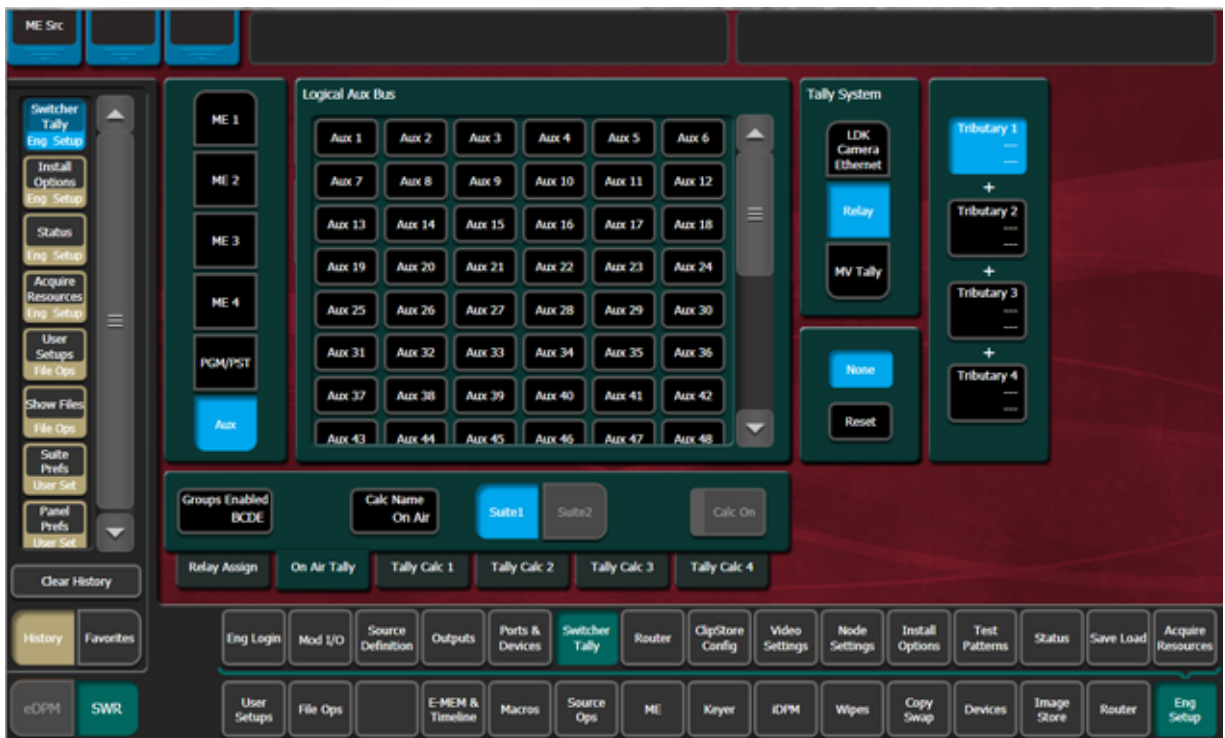

## Creating a Look Ahead Relay Tally Calculator

- 1 Select **Eng Setup, Switcher Tally, Tally Calc 1-4** to access a Tally Calc menu.
- 2 Select the **Calc 1-4 Name** button to open a keypad you can use to name that calculator.
- 3 Select the **Suite 1** or **Suite 2** button for the K-Frame suite that will use this calculator.
- 4 Select a **Tributary** button on the right.
- 5 Select an **ME** or **PGM/PST** button on the left.
- 6 Select a LAP 1-4 button to assign that look ahead to that Tributary.

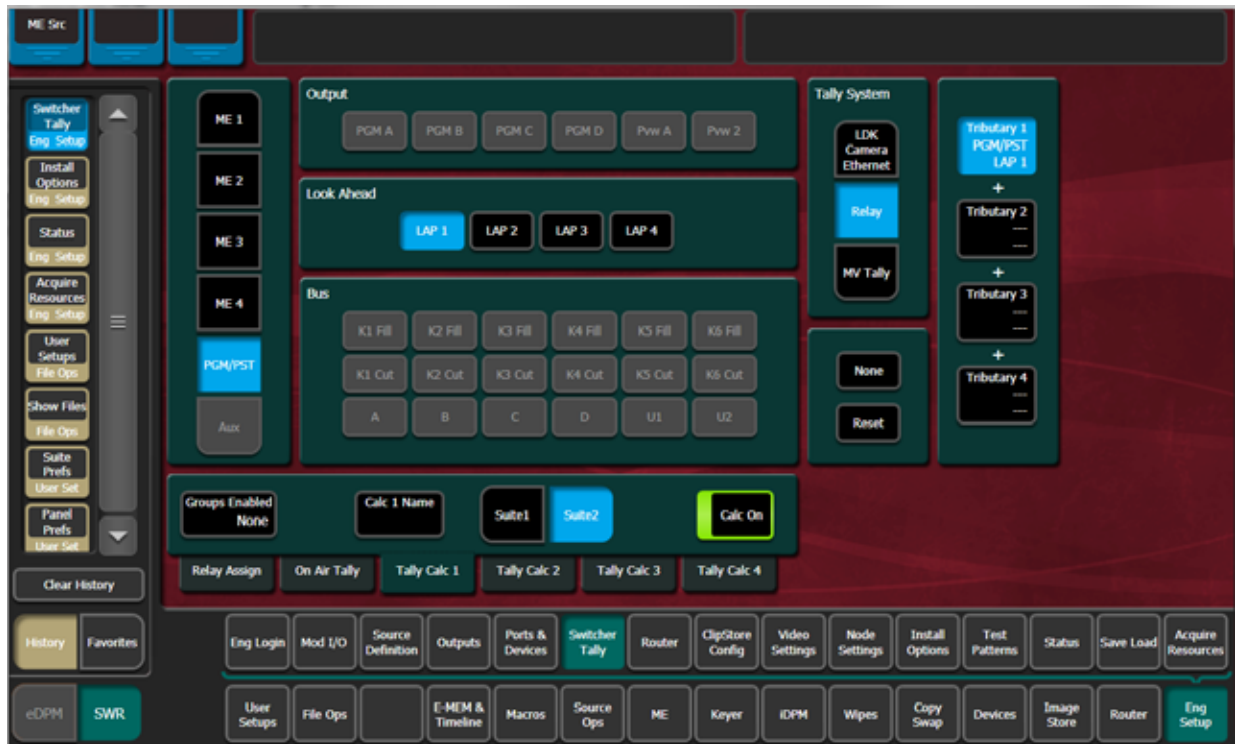

- 7 Repeat to assign all the desired look ahead previews to the calculation.
- 8 To activate this calculator, touch the **Calc On** button so it is highlighted.

---

Note: Though the calculator is activated, it will not actually affect Video Processor Frame relay contacts until that calculator has been assigned to a Tally Group.

---

## Creating a Bus Relay Tally Calculator

Bus tallies report what source(s) are currently selected on a particular set of buses, and does not trace tributaries upstream.

Use the Look Ahead Preview procedure above, but choose PGM/PST, ME, or Aux, on the left, and then select the desired bus in the center of the screen. Repeat for all the buses you wish to tally.





## Relay Assign Menu

The Relay Assign menu is used to assign the Tally Calculators to Relay Groups, and assign Engineering/Fixed Sources to relays on the Video Processor Frame GPI/Tally connectors. Touch the Relay Assign tab to access the menu.





**Tally Relay Group** - Delegates the menu controls to configure the selected Tally Group. The A, B, C, and D Tally Groups correspond to Tally/GPI connectors 1 through 4 on the rear of the K-Frame Video Processor.

**Calculation Enables** - Assigns the Tally Calculators to the delegated Tally Group. When a calculator button is off, that calculator's results will not trigger relays for that Tally Group.

---

Note: A calculator must be activated with its **Calc On** button before it can be assigned to a Tally Group.

---

## Assign Sources to Tally Relays

Sources are assigned to specific relay connectors with the controls on the upper right.

- 1 Touch the button for the desired Relay in the center of the menu.
  - 2 Choose the Engineering or Fixed Source in the scrolling list on the right. The name of the source will be displayed on the Relay button.
- The **None** button clears the current Source assignment for the selected relay.
  - The **Source Number** data pad and scroll dial can be used to quickly select the desired Engineering Source.
  - The **Lock** button can be used to prevent the source list from scrolling automatically to that relay's source. This permits easy selection of adjacent sources.

## About MV Green Relay Tally Calculations for Multiviewer On-Air and Green

On-Air and Green tally calculations are configured and applied the same as Relay tally (see the Installation & Service Manual for your Video Production Center model).

Three common scenarios for MV Green Tally:

---

**Note:** Red On-Air tally overrides Green tally for Multiviewer assigned sources.

---

- **Look Ahead Preview**—In a typical configuration, an LAP calculation can be applied to Multiviewer so any Multiviewer assigned source selected for on-air transition is green tally on the monitor. In this example, the green tally communicates that the source can be taken to air with the next transition. Any upstream sources associated with a Multiviewer assigned source (for example keyers or eDPM channels) will also tally green on the monitor when selected on the PST bus.
- **Aux Bus**—An example of On-Air and Green Aux Bus tally would be to identify on-air sources feeding monitors located behind the talent on a news or sports broadcast.
- **On-Air in another suite**—Selected in the On Air Tally tab, in Eng Setup, Switcher Tally, sources on-air in another suite can be tallied green on the monitor with Multiviewer, allowing the operator to observe when those sources are on-air.

### Configure MV Green Relay Tally for Look Ahead Preview

Applying green tally to LAP (Look Ahead Preview) will place green borders around the Multiviewer windows on a display when sources are on the PST bus, in a typical configuration, communicating that those sources are in LAP and can transition to on-air next.

- 1 Select **Eng Setup, Switcher Tally**.
- 2 Select the **MV Tally** button in the Tally System pane (upper right).
- 3 Select one of the four Tally Calc tabs.
- 4 Select the Calc Name data button and enter a descriptive name for the calculation; **LAP 1** for Look Ahead Preview in Suite 1 as an example.
- 5 Assign tributaries to the four Look Ahead Previews:
  - a Select **LAP 1** then **Tributary 4**,
  - b Select **LAP2** then **Tributary 3**, and so on.
- 6 Turn on the calculation by selecting the **Calc On** button (highlights green when on).
- 7 Select the **MV Tally** tab.
- 8 Select the LAP configured tally calculation; for example **Calc 1 LAP 1**.

## Ethernet Tally Configuration

The GV Switcher system provides all the tally data needed by the Ethernet tally client. Typically, the only user-defined selection for Ethernet tally from the switcher is the on-air

Program ME. PGM/PST is the default on-air tally Program ME, however any licensed ME can be defined as Program. Sources are on or off air based on the Program ME selection.

## Configure the On-Air Tally Program ME

The default on-air Program ME is PGM/PST.

- 1 Select **Eng Setup, Switcher Tally, On Air Tally**.
- 2 Select an available (licensed) ME as the on-air tally Program ME, for example ME 1, ME 2, Aux, etc.

## Configure the GV Switcher Ethernet Tally System Interface

The GV Switcher system must be configured to interface with third party Ethernet Tally systems. An initial tally client port selection can help ensure a successful connection.

- 1 Configure the Ethernet Tally interface IP Address:
  - a In the Eng Setup, Ports & Devices menu, select the **Tally Ports** tab.
  - b In the Tally Contribution pane, select an Ethernet Tally IP Address data pad and enter the IP address for an Ethernet Tally system in the pop-up keypad and press **Enter**.



- 2 Select the adjacent Enable button (highlights green when on).

---

Note: When the connection is enabled, the Connection Status LED turns green.

---

When the connection is enabled, the Connection Status LED turns green.

- At the tally client, set the connection to **Port 2012** to establish the initial connection between the GV Switcher and Ethernet Tally systems.

## Set Source Names with External Ethernet Tally

Support for setting source names through external Ethernet tally clients can be added by tally client developers. Once enabled, the tally client can send data to the Frame that will modify any or all source names in the system, including the Engineering Names for each source. Additionally, the Control Panel, OLED, and Menu names for each logical source in each suite can be set externally.

**Note:** This Tally Protocol enhancement is a superset of the previous version of the Tally Protocol. The 7.0 Tally software is backwards compatible with previous Tally Protocol Clients.

- Select **Eng Setup, Ports & Devices, Tally Ports**.



- Select an Ethernet Tally IP Address data pad, enter the IP Address of the external tally system in the pop-up keypad, and select **Enter**.

The Connection Status indicator for that tally contributor turns green when connected. The Tally Clients pane (right) displays which suites have external Ethernet tally contribution (S1 and/or S2) and tally system information.

Connection Status Indicator colors:

- White—no external Ethernet tally connection
  - Green—external Ethernet tally client is connected
  - Red—external Ethernet tally connection error
- 3 Select the Connection Status **Enable** button to connect to the external Ethernet tally client.
  - 4 Enable the Source Name Control by selecting the **Enable** button for the external Ethernet tally connection.

---

**Note:** Source name control is enabled only when the Connection Status and Source Name Control **Enable** buttons are both enabled (highlighted green).

---

## ClipStore Configuration

ClipStore basic configuration includes preparing the Summit/Solo and K-Frame systems through licensing, IP addressing, software installation, cabling, and GV Switcher menu configurations.

### Summit/Solo Software Version

The latest version of the ClipStore server software is available on the Grass Valley Switcher Software Download site.

---

**CAUTION:** Do not use AppCenter Elite software for ClipStore from the Summit/Solo server web site as it may not be compatible.

---

Do not use AppCenter Elite software for ClipStore from the Summit/Solo server web site as it may not be compatible.

For more information about installing and updating AppCenter Elite software, see the Summit/Solo manuals.

### Setting the Summit IP Address

The ClipStore Summit/Solo server is shipped with the following defaults:

- IP Address: 192.168.0.180
- Mask: 255.255.255.0
- Gateway: 192.168.0.1
- WINS: disabled (0.0.0.0)
- DNS: disabled (0.0.0.0)

You can temporarily change the default settings using Netconfig (see the *NetConfig Network Configuration Application Instruction Manual* at [www.grassvalley.com](http://www.grassvalley.com)).

To set a new IP Address at the ClipStore (Summit/Solo) server, see **<Blue><Italic>Set the Summit/Solo IP Address</Italic></Blue>** on page 166.

The NetConfig Network Configuration Tool can be installed with the K-Frame Switcher Installer software.

Note: Make note of the ClipStore IP Address, it will be used later to enable ClipStores as external devices later in the K-Frame configuration process.

## Install the ClipStore License

Verify that the GV Switcher software is version 5.0 or later. For information about upgrading software, see the *K-Frame User Manual*.

Install the ClipStore license. The following are the ClipStore options:

- KRR-CLPS-2CH-PAK (2-Channel Solo Server Platform)
- KRR-CLPS-4CH-PAK (4-Channel Summit Server Platform)



## Configure ClipStore as a Node

ClipStore must be configured as a node in the Eng Setup, Node Settings menu before the K-Frame system can communicate with the Summit/Solo ClipStore server.

- 1 Verify there is a valid network connection.
- 2 Select **Eng Setup, Node Settings, Frame Suite Nodes & ID** in the GV switcher menu.
- 3 Input a valid IP address for the ClipStore server by touching the **ClipStore IP Address** data pad, typing the address, and touching **Enter**.
- 4 Select **Enable**.

- The Enable button allows communication between the K-Frame and the ClipStore server and highlights green indicating a proper connection. Red will show no connection and yellow shows that some channels are connected. For both red and yellow indications, ensure that channels are in AMP mode and available for remote control. Other troubleshooting may be required.



## Configure Source Definitions

To configure source definitions for ClipStore return outputs, choose a source, a source type "Device", an input fed by the device, a Key Mode, and an Engineering Name for the source if desired.

The following example demonstrates the configuration of a Summit with four ClipStore channels. In this example the physical BNC connections from the ClipStore to the K-Frame are Inputs 25-32.

ClipStore can record Video only, Key only, or Video/Key clips. To do this, both a video and a key for the video must be configured for each ClipStore channel.

To configure a ClipStore source of a video/key pair as a video fill source:

- Select **Eng Setup, Source Definition** in the menu.
- From the Source List, select a source.
- Use the default video input (Video In:) or change it using the **Video Input** data pad.
- Select **Linear Key**.
- Use the **Key Input** data pad (or soft knob) to select the source number of the Key source you will use for the ClipStore channel.



- 6 Configure the Source Type:
  - a Select the **Device** mode button in the Source Type pane.
  - b Select the **External Device** data pad, the External Device List is displayed.
  - c Select a **CS channel**.

The External Device List closes and the Engineering Name is filled in with the ClipStore External Device name automatically.

To configure a source as a ClipStore Key input (Key input to the ClipStore Video input created earlier):

- 7 From the Source List, Select a source.
- 8 Select the **No Key** button in the Key Mode (if not selected).
- 9 Use the default video input (Video In:) or change it using the **Video Input** data pad.
- 10 Select the **Direct** mode button in the Source Type pane.
- 11 Give the ClipStore key input an Engineering Name if desired by Selecting the **Engineering Name** data pad and entering the name in the pop-up keyboard.

You now have device control over this ClipStore resource, and it can be mapped. Repeat the preceding steps for each ClipStore channel.

## Configure Outputs

Set the switcher outputs that are feeding into ClipStore. By selecting an Aux bus then touching one of the CS-1 through CS-4 enable buttons, those Aux bus outputs will be paired. In other words, if you select the output, then Aux 5, Aux 5a and Aux 5b will be paired as a ClipStore Video/Key pair when the ClipStore button is enabled.

- 1 Go to the Outputs menu by touching **Eng Setup, Outputs**.
- 2 Select the odd numbered output (first Aux bus output assigned for a video/key pair must be odd/fill) that you wish to use as the input to ClipStore. Then select Aux as the Output Type and the desired logical Aux bus.
- 3 Select one of the ClipStore buttons.
- 4 Repeat the preceding steps for each channel of ClipStore.

---

**Note:** You only need to configure all channels as video/key if you wish to record on all channels.

---

The Engineering Names for each ClipStore channel will appear in the Local Aux area and/or can be button mapped as desired.

## Acquire and Assign CS channels in another suite

- 1 In the Outputs menu, deselect the CS channels to be acquired.
- 2 Select the **Suite 1** or **Suite 2** button to change suite delegation.
- 3 Re-acquire the CS outputs by Selecting the CS buttons (CS-1, CS-2, etc.).

It is recommended at this point that you save a new Eng Setup file that includes these changes.



## ClipStore Config Menu

The ClipStore Config menu is used to configure the ClipStore input/output parameters and read those input/output parameters from, or send them to, the ClipStore server.



**Read from ClipStore button**—Updates the Eng Setup, ClipStore Config menu with the current parameter settings for the configured ClipStore server channels.

**Send to ClipStore button**—Sends all parameter and system settings required by ClipStore to record, edit, and control clips to the server. Any changes to the Record Setup or Replay Setup parameter settings will also be sent to the ClipStore server. A dialog is displayed when this button is pressed, stating that all clips will be ejected as part of this operation; keep this in mind if considering this operation during a broadcast.

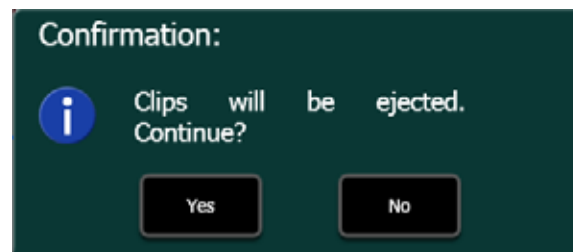

The ClipStore Source Numbers Pane (read-only), provides channel and source information, for example CS-1025 means ClipStore Channel1 (CS-1), Eng Source ID 25 (025).

**Bars and Tone button**—Turning this button on (highlighted green) then selecting the **Send to ClipStore** button, loads color bars (and updates the configuration) and sends a tone to the selected ClipStore channel for testing.

## Assigning ClipStore Channel Resources to a Suite

ClipStore resources can be acquired in suites. ClipStore suite assignment buttons in the Eng Setup, Acquire Resources, Effects, Stores, & Viewers menu. For information about acquiring suite resources (see [Divide Resources Between Suites](#), on page 188).

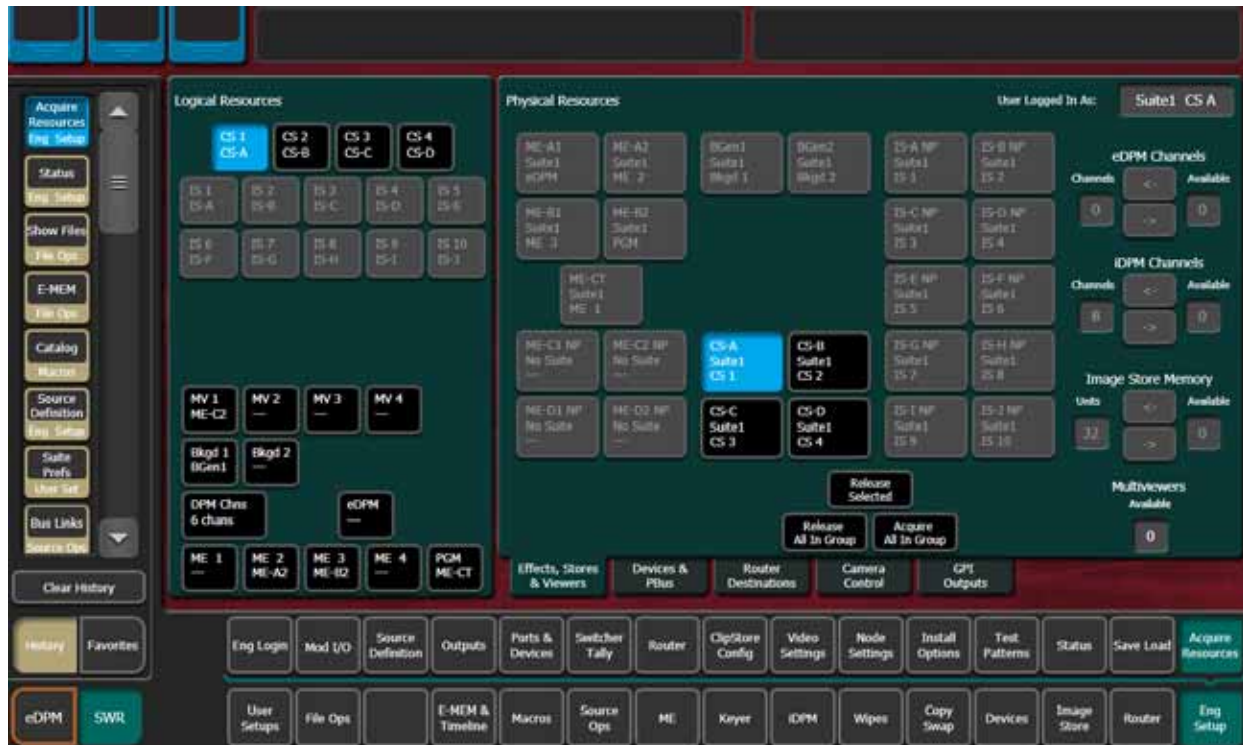

### Set the Summit/Solo IP Address

See the Summit/Solo manuals packaged with the system.

### Configure the Remote Desktop Connection

To create a Remote Desktop Connection with the Summit/Solo, perform the following:

- 1 Minimize the GV Switcher menu on the menu Panel (or PC).
- 2 In Windows, click **Start, Programs, Accessories, Remote Desktop Connection**.
- 3 Enter the current IP Address for the Summit/Solo server. (default IP Address: 192.168.0.180) in the Remote Desktop Connection dialog.
- 4 Click **Connect**.
- 5 Enter the following in the Log On to Windows dialog:
- 6 Login: **administration**
- 7 Password: **adminK2**, touch enter.
- 8 The Elite AppCenter application window is displayed.
- 9 For Windows XP only: Disable the FBWF (File Based Write Filter).
  - a Click the **Start** menu and navigate to **All Programs, Grass Valley**.

b Click the **Write Filter Utility** (top of list).

Result: The FBWF Manager is displayed.



c Under Filter Settings click the **Filter:** pull-down menu, click **Disable** (Enabled is the default), and click **OK**.

Result: An asterisk (\*) will appear next to 'Disable' that indicates the system must be rebooted to implement the configuration change.

Basic Configuration  
Configure the Remote Desktop Connection

---

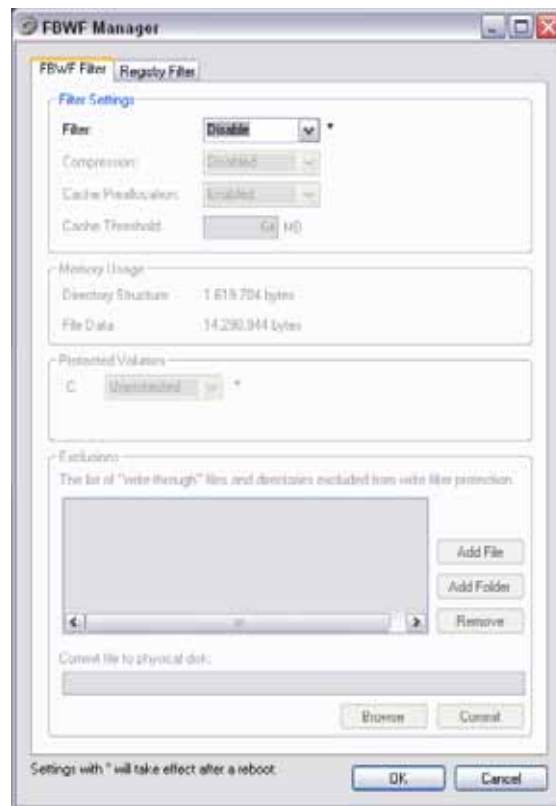

d At the reboot prompt, click Yes.

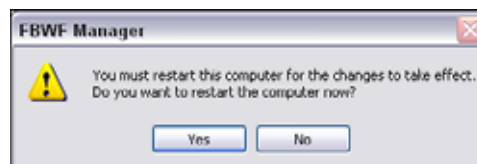

- 10 Right-click on **Network Places**.
- 11 Click **Properties**.
- 12 Right-click on **Control Team**.

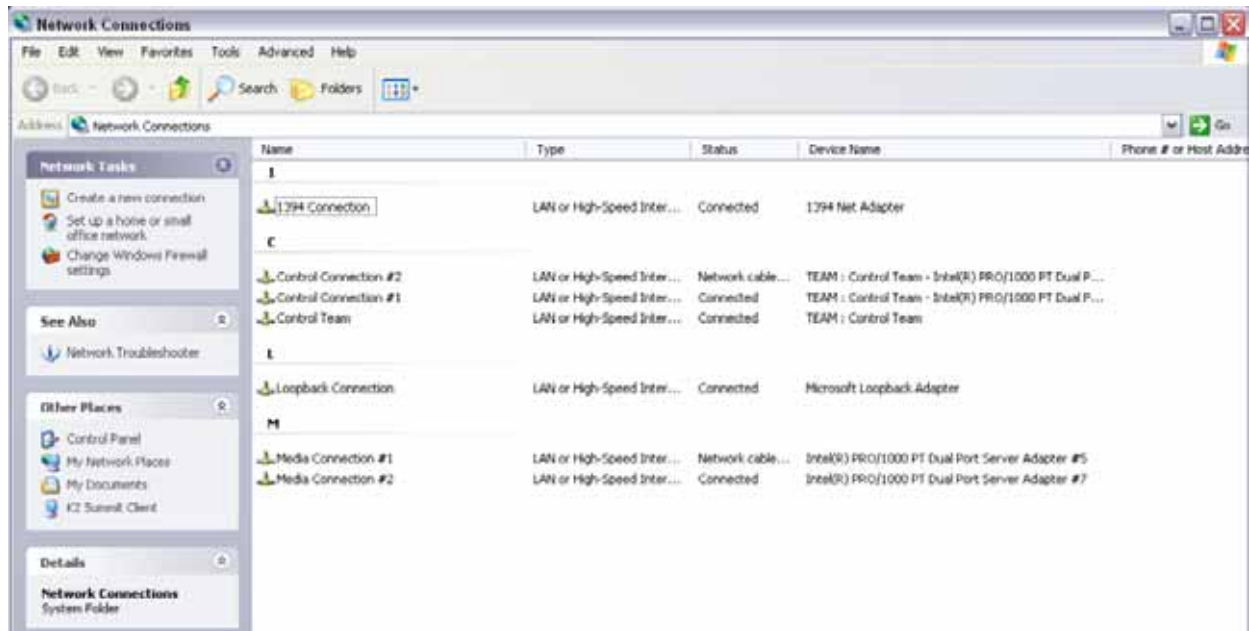

13 Click **Properties**.

14 Scroll down to "Internet Protocol (TCP/IP)" and click to highlight it.



15 Click **Properties**.

The TCP/IP Properties Dialog is displayed.

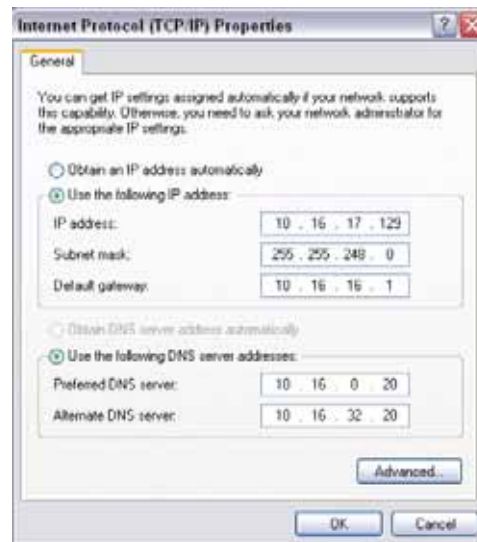

- 16 Enter the desired IP Address, and click **OK**.
- 17 The Subnet mask will be filled in automatically.
- 18 Click **OK**.

#### **For Windows XP Only: Enable the FBWF**

- 1 Enable the FBWF (File Based Write Filter), see [Setting the Summit IP Address](#).
- 2 Reboot the ClipStore Summit/Solo server.

## 4K Frame Operating Mode Configuration

Placing the switcher in a 4K Frame Operating mode ([Configure a 4K Frame Operating Mode Video Setting](#)) automatically acquires and configures physical ME resources as 4K, in Suite 1. The result is four full 4K MEs, with three 4K keyers each.

Each logical 4K ME is configured from two physical MEs; referred to as VPEs (Video Processing Engines). VPEs are placed in split mode so each partition is one 1080p sub-image of a 4K stream. Each sub-image is one fourth of a 4K image that is routed through the switcher.

4K Quad modes require additional user setups, see the *K-Frame Kayenne/Karrera/GV Korona User Manual* for this and other information including how to setup 1080p 4K sub-images as a lower third, split screen, or flying 4K DPM effects over a 4K background.

## System Requirements

A K-Frame Standard or Compact Frame is required to operate a Grass Valley switcher in 4K Frame Operating modes.

## 4K Physical ME to logical ME Acquisitions

The following shows a four ME system however systems with fewer resources would be acquired in the same manner, starting with the PGM/PST ME.

---

ME-CT is a 1080p (not 4K) acquirable resource with six keyers, available in all 4K modes.

---

VPE (Dual ME) Card	4K Logical ME
ME-A (ME A1/A2)	PGM/PST
ME-B (ME B1/B2)	ME 1
ME-C (ME C1/C2)	ME 2
ME-D (ME D1/D2)	ME 3

## Configure a 4K Frame Operating Mode Video Setting

Selecting a 2SI (2 Sample Interleave) or Quad Frame Operating Mode automatically places the switcher ME resources in the 4K configuration.

- 1 Select **Eng Setup, Video Settings**.
- 2 Select a 4K 2SI or 4K Quad mode in the Frame Operating Mode menu pane.

## About Releasing Resources in 4K Mode

The Controller VPEs (MX-MV and ME-CT) resources can be released and acquired by another suite without affecting the 4K ME configuration. The Controller VPEs (Video Processing Engines) are configured as 1080p resources only, in 4K Frame Operating modes.

## Configure a 4K Source Definition (Video Inputs)

Defining a source as 4K automatically assigns four physical inputs to the logical Eng ID; the selected input plus the next three. For example, selecting Video Input 10 in Eng ID 1 in 4K mode, makes Video Inputs 10, 11, 12, and 13, sub-images of Eng ID 1.

- 1 Select **Eng Setup, Source Definition**.
- 2 Select an Eng ID from the source list.
- 3 If necessary, select a Video Input using the soft knob (right) or by selecting the Video Input data pad and entering a number in the keypad and selecting **Enter**.
- 4 In the Resolution pane, for Video, select **4K**.
- 5 Repeat for each 4K source.

## Configure a 4K Key Source Definition (Key Inputs)

Defining a source as 4K automatically assigns four physical inputs to the logical Eng ID; the selected input plus the next three. For example, selecting Key Input 20 in Eng ID 1 in 4K mode, makes Key Inputs 20, 21, 22, and 23, sub-images of Eng ID 1.

- 1 Select **Eng Setup, Source Definition**.
- 2 Select an Eng ID from the source list.
- 3 If necessary, select a Key Input using the soft knob (right) or by selecting the Key Input data pad and entering a number in the keypad and selecting **Enter**.
- 4 In the Resolution pane, for Key, select **4K**.
- 5 Repeat for each 4K source.

## Configure a 4K Output

Defining a physical output as 4K automatically assigns a group of four outputs (e.g. 1-4, 5-9, 10-14, etc.) as part of that 4K stream. For example, if Output 3 is selected, Outputs 1, 2, 3, and 4 are automatically selected and will output the 4K sub-images of the selected source.

- 1 Select **Eng Setup, Outputs**.
- 2 Select an output from the Physical Outputs list.
- 3 If necessary, select an output using the menu soft knob (right) or by selecting the Output data pad and entering a number in the keypad and selecting **Enter**.
- 4 In the Resolution menu pane, select **4K**.

### Setting the Payload ID

The Payload ID identifies the output as a 2SI signal and embeds the sub-image ID number in the Payload ID. This supports newer monitors with 2SI auto-detection. Payload ID is configurable by selecting the Link.

- 1 Select an output in the Physical Outputs pane.
- 2 Select **4K** in the Resolution pane (it will work in HD mode but only with monitors that support 2SI).
- 3 Turn on **Payload ID** in the 4K Link pane. The link is shown in the Link button label, selecting the **Link** button opens the Payload ID menu allowing you to change the link associated with the Payload ID.



## Camera Control with Ethernet Tally Configuration

The K-Frame system uses Ethernet to communicate with the LDK Connect Gateway. Some basic configuration is required in the Eng Setup menu.

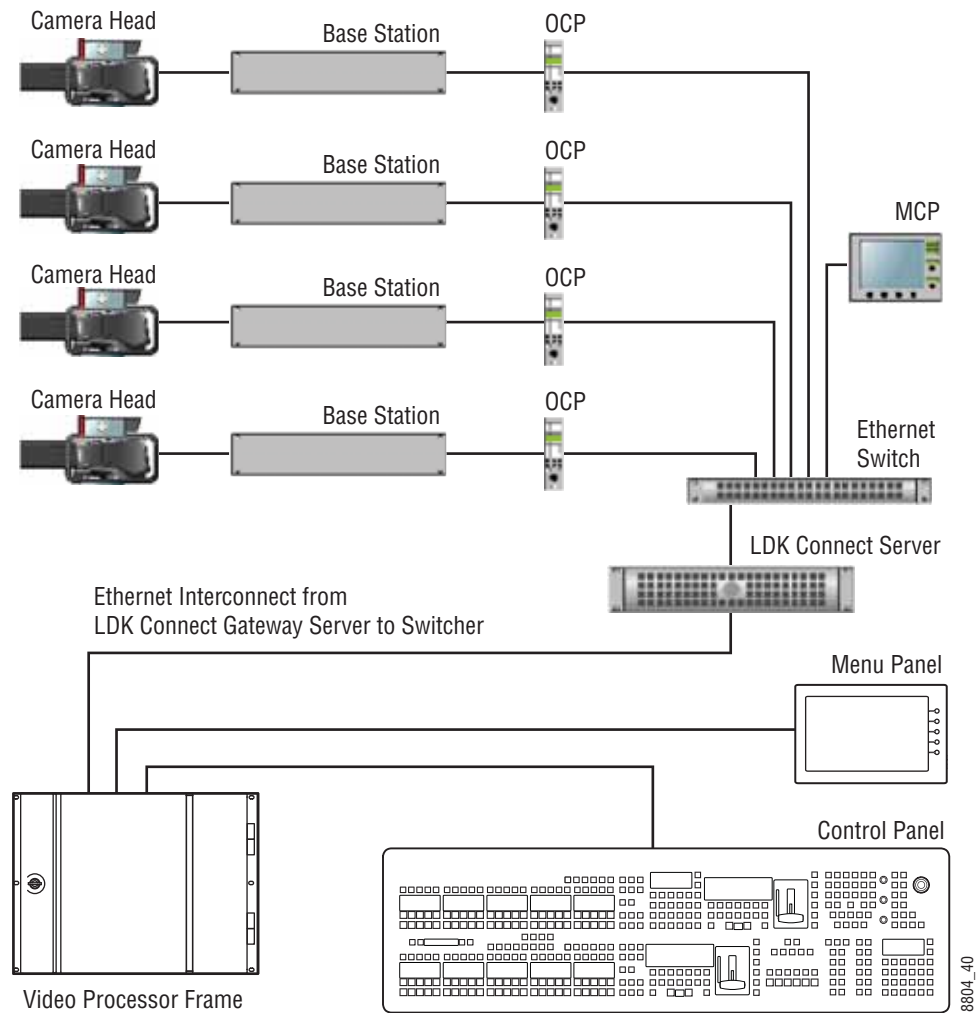

*K-Frame System Interconnection with Camera Gateway*

## Configure Node Settings

- 1 Select **Eng Setup, Node Settings** in the menu.
- 2 Enter a valid IP Address for the camera gateway and select **Enable**.  
Result: When connected, the LDK Connect LED will turn green.



## Configure Source Definitions

To enable camera control from the K-Frame, the source is defined as a "Camera" type then assigned as a camera in the Eng Setup, Source Definition menu.



- 1 Select the desired source in the Source List.
- 2 Set the Video Input and Key Mode (see the *K-Frame User Manual* for more information).
- 3 Select the Camera source type button in the Source Type pane.

Once the “Source Type” is defined as Camera, the Camera Source can be selected.

- 4 Select the **Camera Source** data pad—the Ethernet Connected Camera List pane is displayed.



5 Select a camera in the Ethernet Connected Camera List.

The Ethernet Connected Camera List pane closes and the selected camera's Engineering Name is defined by the selection automatically. A green **Status LED** signifies a connected camera.

---

**Note:** The Engineering Name of the source becomes "Cam##" and cannot be edited, however the Panel, OLED, and Menu Name can be changed in the Source Patch menu (see the *K-Frame User Manual* for more information).

---

## Acquire Resources

A camera resource can be acquired by Suite 1 or Suite 2 but not both (E-MEM control is only from the suite currently controlling the camera source). Camera resources are acquired in the Eng Setup, Acquire Resources, Camera Control menu.

Camera resource acquisition is represented in the Camera Controls Acquired in Suite pane in the Camera Controls menu as follows:

Green—Successfully acquired in the current suite

White—Resource not acquired in any suite

Blue—Resource successfully acquired by a suite other than the current suite



Acquire control of camera components in another suite by releasing one, several, or all components from the current suite using the **Release Selected** and **Release All Cameras** buttons, changing suites, then acquiring those components in the other suite. For more information on acquiring resources, see the *K-Frame User Manual*.

- 1 Select the components (cameras) you wish to acquire in another suite in the Components: Camera Control pane.
- 2 Release those components using the release buttons.
- 3 Select **Eng Setup**, **Eng Login** and select the **Change Identity** data pad.
- 4 Select the data pad of the desired suite.
- 5 Select **Eng Setup**, **Acquire**, **Camera Control** and select the component buttons you wish to acquire to the suite.
- 6 Select **Acquire Selected**.

## Switcher Ethernet Camera Tally

The K-Frame system provides a quickly connected, reliable, three color tally (Red, Yellow, and Green) via Ethernet to Grass Valley cameras.

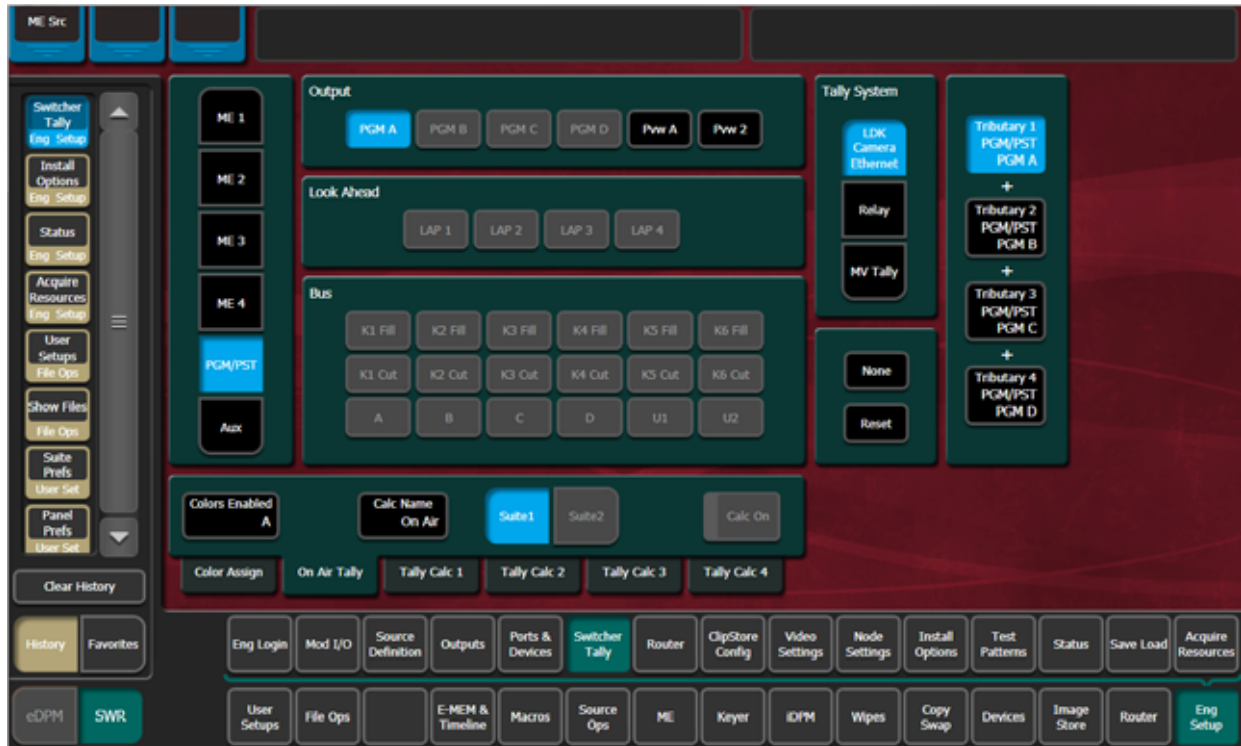

## Tally Calc Menus

As with Switcher Tally, the LDK Camera Ethernet menu is used to select calculators, name calculators, and assign bus contributors to tributaries.

**Colors Enabled**—Reports which colors are currently using that calculator, by color letter corresponding to the viewfinder indicators:

- R (Red=On-Air),
- Y (Yellow=media (record)), and
- G (Green=ND/RE or 'Call').

## Color Assign Menu

Assigning a source as a Camera type and giving it a Camera Number is similar to assigning a source to a relay in a Switcher Tally Group.

The Color Assign menu is used to assign the Tally Calculators to the Tally Colors. Touch the Eng Setup, Switcher Tally, Color Assign menu tab to access this menu.





## User Setups

User Setups are intended primarily for operators, to allow them to customize their working environment. However, some settings affect basic system operation. The engineer in charge of a K-Frame system should create and save at least one default set of User Setups (Panel Prefs and Suite Prefs) so the system can be set to a known state.

Particularly important settings are described briefly below. Refer to the separate *K-Frame User Manual* for more information about User Setups.

## Configuration File Save and Load

### K-Frame File Browser

The K-Frame system has a file browser. You can browse through folders on the local K-Frame Menu hard disk, the K-Frame Video Processor, and the entire network file hierarchy of mapped drives. The various browser menus can be accessed via the **File Ops** menu tab.

# Basic Configuration

## Configuration File Save and Load

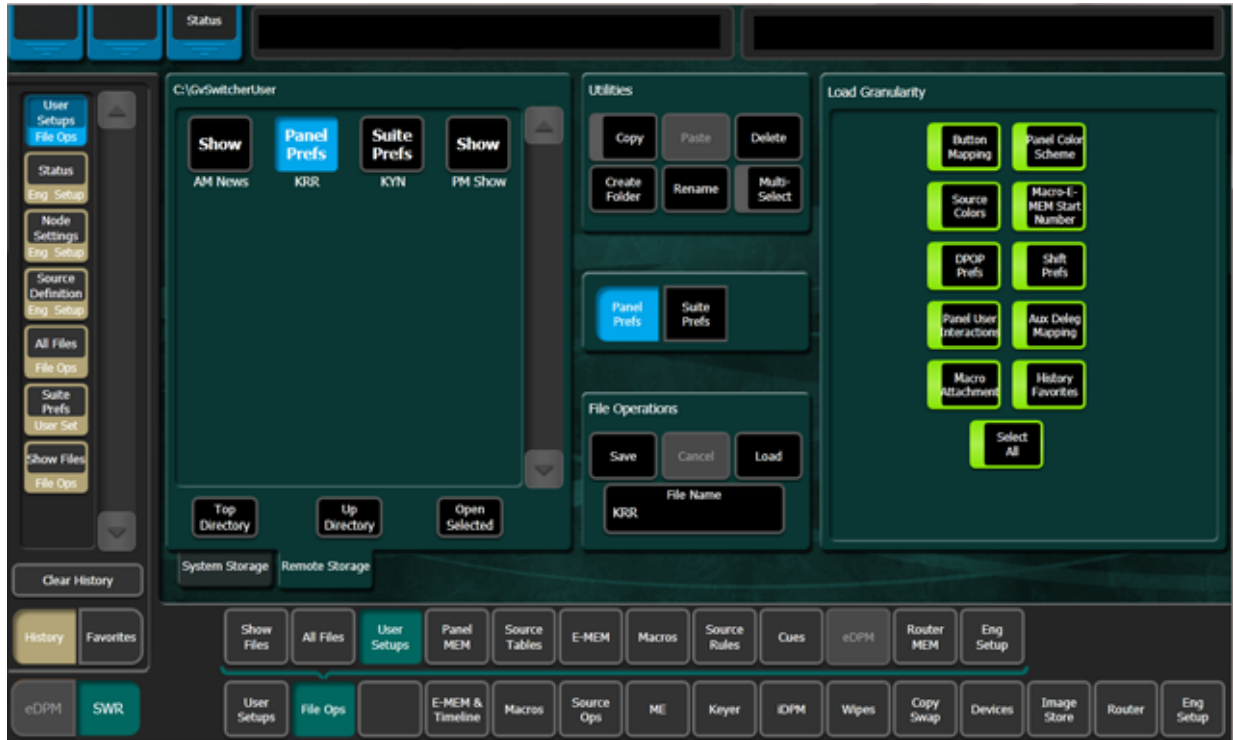



Eng Setup files can be accessed two ways, via **File Ops**, **Eng Setup**, or via **Eng Setup, Save Load**.

Figure 1. Eng Setup Save-Load Menu

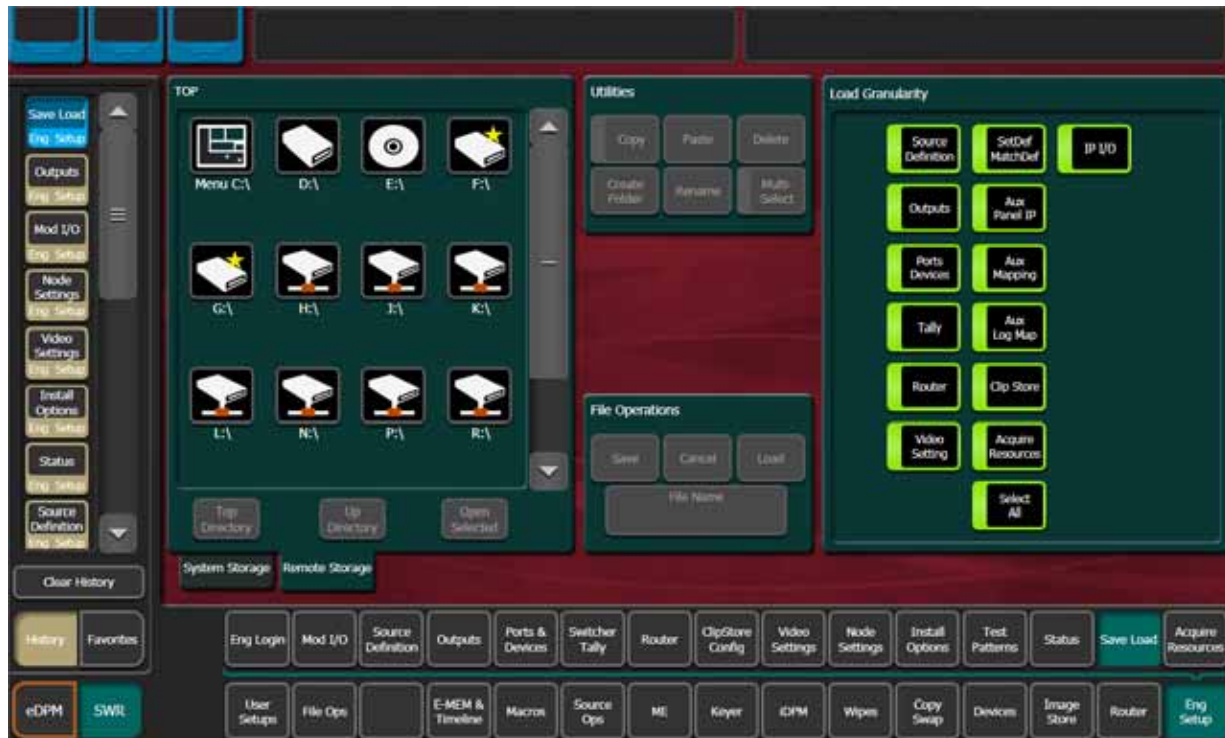

## File Storage Organization

The file browser gives you great flexibility for choosing and creating storage locations for your files. Any number of folders can be created in various locations. File folders and the files themselves can be named in any manner. To prevent accidentally saving and loading incorrect files, your facility should establish file storage and naming conventions and follow them consistently.

The engineer in charge should create default Eng Setup, Panel and Suite Prefs files that are not to be modified by anyone. These can provide a known starting point for users when they build their own preference files.

## K-Frame Drive Access

The K-Frame File Operation menus can access directories located on the USB Memory Stick in the Video Processor Frame (System Storage) and the Menu Panel hard drive (Remote Storage). Local and network drives mapped on the Menu Panel's Windows system are also accessible (Remote Storage). Standard Windows functionality automatically maps all local drives during startup. Mapping network drives to a drive letter using the Windows Explorer allows them to appear at the top of the File Operation menus on that menu system.

Files saved to the **System Storage, Frame User Directory** will be available to any system user.

Files saved to the **Remote Storage, Menu C:\** location on the K-Frame Menu Panel will be available to any user of that Menu Panel. Multiple K-Frame Menu Panels operating with that system will not be able to access files stored at this location on another Menu Panel, unless drives are mapped.

Files can also be saved to an external medium, like a USB Memory Stick, and then removed for personal storage unavailable to other users.

Save important files to multiple locations (for example, to the Video Processor Frame, Menu Panel, and a USB Memory Stick), clearly identify the files (perhaps including the date in the file name), and store removable media containing these files in a safe place.

## Eng Setup File Operations

The Eng Setup, Save Load menu is used to save and load engineering setups information. Only this file format is supported in this menu.

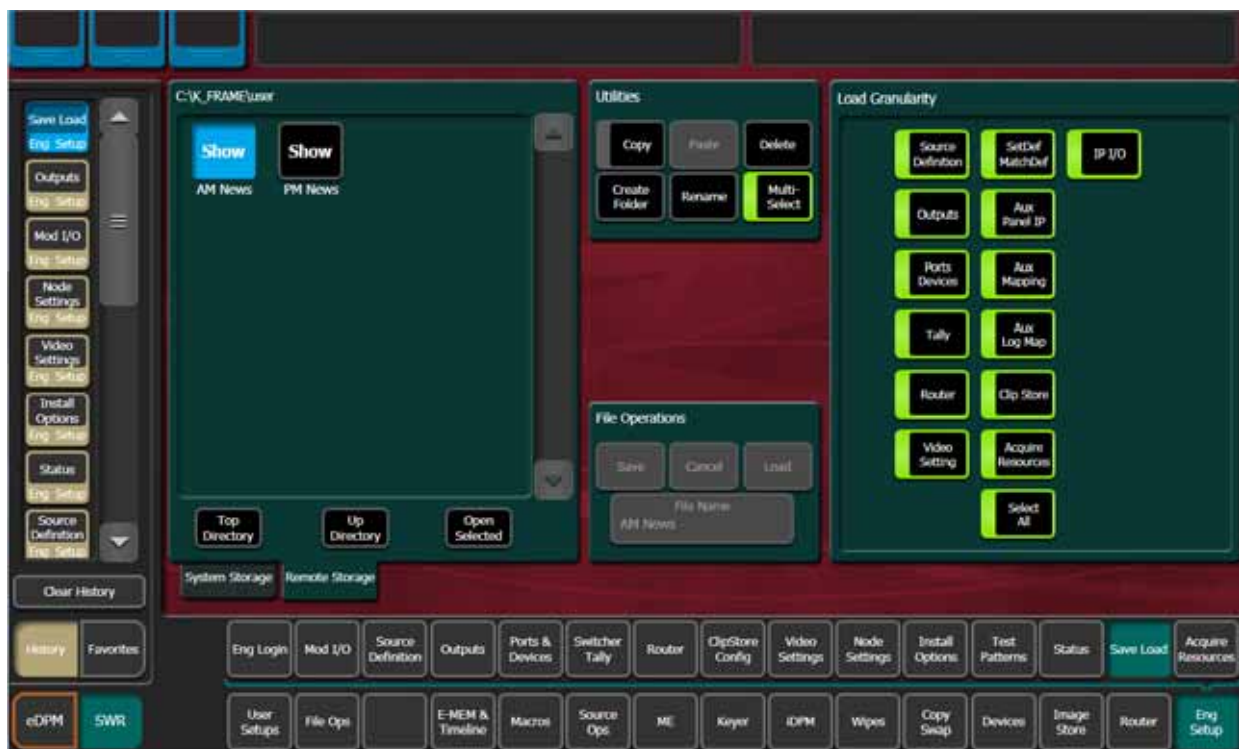

## Save Eng Setup Files

- 1 Select all or individual file types to save.
- 2 Select the **File Name** data pad and enter the name you wish the saved file to have.
- 3 Navigate to the desired destination directory using the buttons in the left navigation pane. You can create and name a new directory for the file with the **Create Folder** button in the Utilities pane if you wish.

- 4 Touch the **Save** button.

## Load Eng Setup Files

- 1 Navigate to the directory containing the files you wish to load, using the buttons at the bottom of the left navigation pane.
- 2 Select the file(s) to be loaded (choose the **Multi-Select** button for multiple files).
- 3 Select **Load**.

**CAUTION:** The Load button immediately replaces information the K-Frame system is currently using with the selected file information. When configuration files are loaded, significant changes to system operation are possible.

## Multiple Suite Resource Sharing

The Resource Sharing feature permits the allocation of K-Frame system resources between two suites. This allows independent system operation from multiple locations without conflict.

Logical resource assignments allow the reuse of E-MEM effects in either suite regardless of which specific hardware resources were allocated.

Each suite can be run with its own Suite Prefs settings, and two different Panel Prefs preference settings can operate simultaneously in each suite. These preferences can be saved and loaded, permitting reliable system changes to meet varying requirements.

The system retains the current suite/resource relationships. If the system powers down or is reset, resource allocations for each suite are restored when the system returns to operation.

## Collaborative Resource Sharing

Collaborative resource sharing permits a group of operators to have simultaneous access to a resource. For example, a video operator may want access to an ME so he can set up a chroma key, but the operator also wants control of that ME so that he can put the chroma key on air. This type of sharing is available simply by installing additional Control Panels.

Corroborative system operation has inherent limitations. Since one operator can change the settings used by another operator, it is assumed the operators are in close communication with each other so they can avoid system control conflicts.

If two conflicting corroborative commands are sent, the K-Frame system ends in the state of the last command processed. For example, one operator could select a source on a bus of an ME at nearly the same time another operator selects a different source on that same bus. The output of that ME will momentarily display the first source and then switch to the last source selected, possibly causing an apparent flash on that output.

The Resource Sharing feature allows collaborative sharing of system components with different User Prefs. For example, when a smaller 25 source panel is used in a corroborative environment with a larger 35 source panel, the button mapping for the two panels must be different because of the different number of source buttons available.

## Independent Resource Sharing

Independent resource sharing isolates an operator or group of operators from other operators, by defining two separate suites. When one suite has acquired a resource, only the operator or group of operators in that suite will be able to control it. An example of independent sharing is splitting a 4-ME K-Frame system into two independent 2-ME switchers.

When a suite acquires a physical resource (like an ME) it uses that resource logically. For example, the ME B physical resource can be used as a logical PGM PST bank. Each of the two switchers created can therefore have their own PGM PST bank, and this allows effects built in one suite to operate correctly when loaded and run in the other suite. Effects will also run correctly in the same suite when run at a later time even if different physical resources have been acquired. Resources can be released by a suite. Once released, these resources can be acquired by the other suite. This permits dynamic reconfiguration of the system resources to meet varying operational requirements.

## Suite

A suite is a grouping of one or more control surfaces (described below), and constitutes a coordinated working environment. Resources are attached to a suite rather than to individual control surfaces. All control surfaces in one suite have access to all resources assigned to that suite (collaborative sharing). Control surfaces in one suite are not able to control resources assigned to the other suite (independent sharing). Suites provide isolation from operators in the other suite.

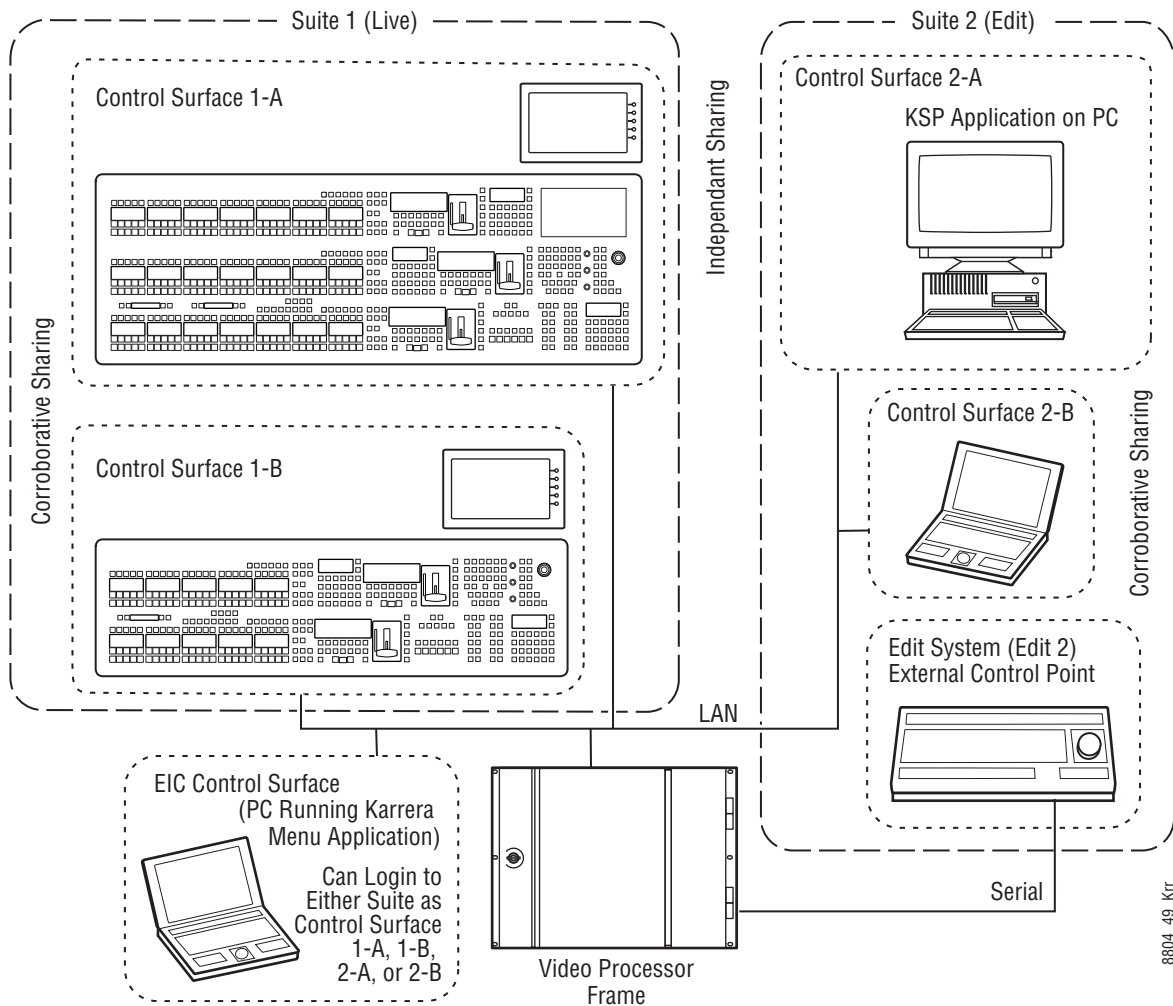

8804\_49\_krr

## Control Surface

A control surface is generally a group of panels which interact and provide a single user a unified work surface. An example of this type of control surface is a Control Panel and Menu Panel of a 4-ME K-Frame system. These panels combine to form a Technical Director's (TD) control surface. Other Control Panel modules or additional Menu Panels can be added to a control surface.

A control surface may also consist of a single item. For example, a Menu Panel (or a laptop computer running the GV Switcher menu application) can act as a separate control surface in a suite.

With Resource Sharing, up to two control surfaces can be created for each of the two suites. Each control surface can load its own Panel Prefs, so they can behave differently from one another. For example, different sources can be mapped to the source select buttons of the two control surfaces in the same suite, permitting quick access to different sources appropriate for each work location.

Control surfaces allow operators to collaborate on the same production while providing isolation between the operators themselves. For example, a smaller Control Panel set up in the studio for rehearsals will need access to the same effects as a larger Control Panel in the control room, but may need access to a specific set of sources. The smaller panel also requires a different button mapping. If a Menu Panel is associated with each Main panel, the DPOP operations of one panel should affect its menu, not the other one.

## Logical Aux Buses

Each suite can be configured to have its own set of numbered Logical Aux buses. This means effects built for one suite will run properly in the other as long as the physical connections for the same numbered logical Aux buses are similar. For example, if Aux bus 5 in one suite is used to feed that studio's monitor wall, using Aux bus 5 in the other suite to also feed that studio's monitor wall will make effects compatible between the suites. Note that these Aux buses have different internal paths and different physical connections, but share the same logical Aux bus number.

## Remote Aux Panels

Remote Aux Panels are set up as part of a particular suite. They then become another control surface of that suite, with functionality limited to controlling only the Aux buses assigned to that suite.

## External Control Points

Some types of K-Frame system control originate from an external location, like an edit controller, or a GPI contact closure. The Resource Sharing feature accommodates these control points differently.

A separate editor port can be assigned to each suite. An edit controller connected to each port is considered part of only that suite, and controls only the resources currently acquired by that suite.

GPI inputs themselves are not assigned to individual suites. Each suite can be configured to respond to particular GPI commands, with the other suite ignoring these commands.

## Setting Up Resource Sharing

Your K-Frame system should first be fully operational. For new customers, an initial system configuration will be required. This basic setup will become the baseline for suite 1 operation. This includes having an Eng Setup configured with the sources defined, suite 1 outputs assigned, suite 1 tally contacts connected and Ethernet tally defined (if used), and any external interfaces (DDR, VTR.) that will be used in suite 1 should be installed and operational.

Default Suite Prefs should also be defined and saved under a file name identifying its use for suite 1. A default Panel Prefs file should also be defined and saved identifying it as a default setting for control surface A of suite 1. All these files will become the starting point from which changes will be made to make full use of Resource Sharing.

When the above is accomplished and basic system functionality is confirmed, you can then set up suite 2, and more easily troubleshoot any configuration issues that may arise.

If you will be adding new system components for use with Resource Sharing, all these components must be installed and configured on the network, using valid IP addresses. All control surfaces participating in Resource Sharing will also need to be in communication with the same Video Processor Frame. After the primary Main panel has been installed and its connectivity verified, one new panel should be installed and its connectivity also verified before you install any additional panels. This will make it easier to troubleshoot any IP addressing problems that may occur.

## Prepare Worksheet

A worksheet is helpful for planning your multi-suite installation and configuration. The worksheet should list all Control Panels, Menu Panels, and PCs running the GV Switcher menu application, their IP addresses, and their suite and control surface associations. It should also list all Remote Aux Panels and which suite they belong to. Physical outputs should also be listed with their suite association and which Fixed output or Aux bus they are associated with, the main program and preview outs for the suite, etc.

## Configure Control Surfaces

- 1 Select **Eng Setup, Node Settings, Control Surfaces**, and enter the IP address and name the control surface you are adding. Assign it to **Suite 2 Surface A**. If you are using an additional Menu Panel or PC for that suite, you can change it to **Suite 2 Surface A** at this time as well.



- 2 Select **Reset Panel**. This will re-establish system communications. After reboot, the Eng Setup, Status menu will display the added control surface.



## Define Default Multi-Suite Engineering Resources

Assign the following items as appropriate to suite 1 or suite 2:

- Outputs (Pgm, Switched Preview, Aux Buses, etc. accessed via **Eng Setup, Outputs**).

Each suite has its own, logical set of outputs that are identically numbered. Use the **Suite 1** and **Suite 2** buttons to assign them to a suite.

- GPI Outputs (**Eng Setup, Acquire Resources, GPI Outputs**).
- Editor Ports, if used, are permanently assigned for use by each suite (**Eng Setup, Ports & Devices, Editor Ports**).
- Switcher Tally (**Eng Setup, Switcher Tally**).

---

Note: Each suite has its own, logical set of outputs that are identically numbered. Use the Suite 1 and Suite 2 buttons to assign them to a suite.

---

## Divide Resources Between Suites

---

Note: Changes to Suites and Resource Sharing can have serious K-Frame system operation impacts that may not be completely obvious. For this reason, precautionary messages requiring a response are posted.

---

- 1 If necessary, select **Eng Setup, Eng Login** and answer **Yes** to the warning message, and login as **Suite 1 CS A** using the **Change Identity** button.



- 2 Select **Eng Setup, Acquire Resources** and select **Yes** to the warning message, and release resources not needed in suite 1 that you wish to make available to suite 2. You can use



the category tabs on the right to release resources in each category, and then acquire only what is needed in suite 1.

1

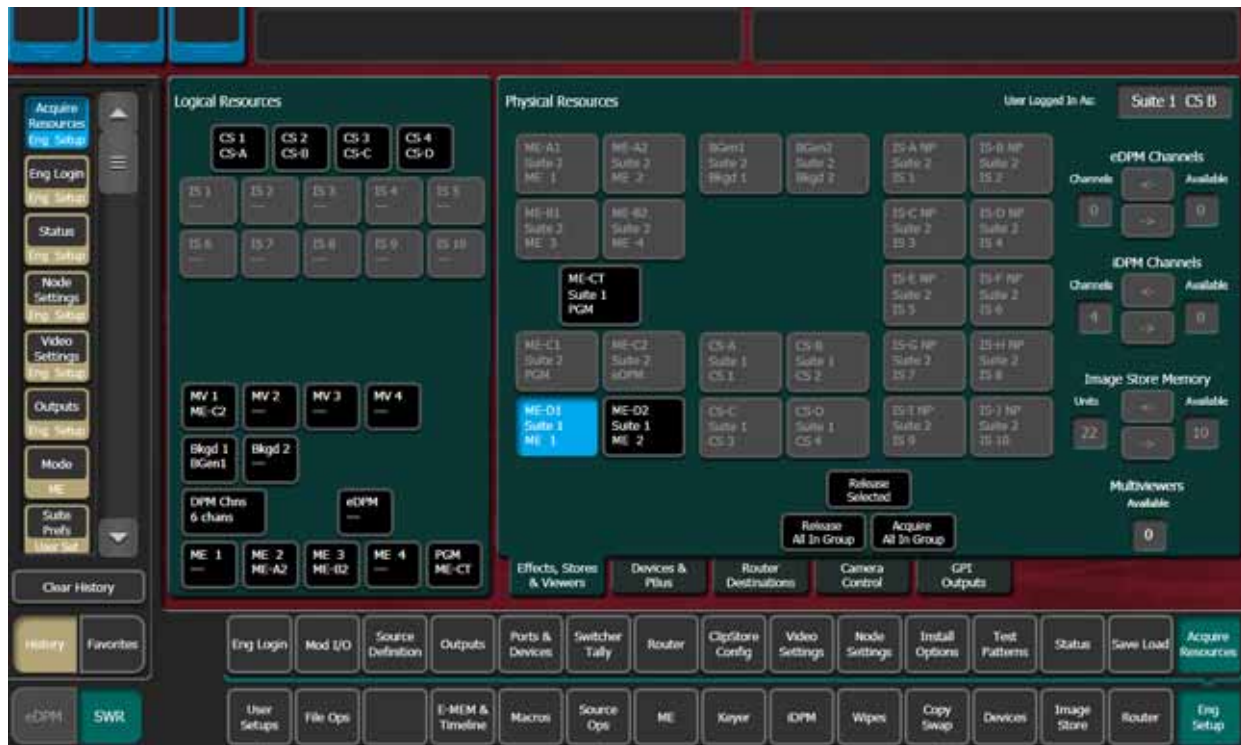

- 3 To acquire installed DPM options, move available iDPM Channels from Available to Channels using the arrow keys. Any number of licensed iDPM channels can be acquired to the selected resource, or acquired as eDPMs using the Acquire Resources menu.
- 4 Select **Eng Setup**, **Eng Login**, and use the **Change Identity** button to login as **Suite 2 CS A**. Then select **Eng Setup**, **Acquire Resources** and acquire the resources needed in suite 2 that have been freed in suite 1.

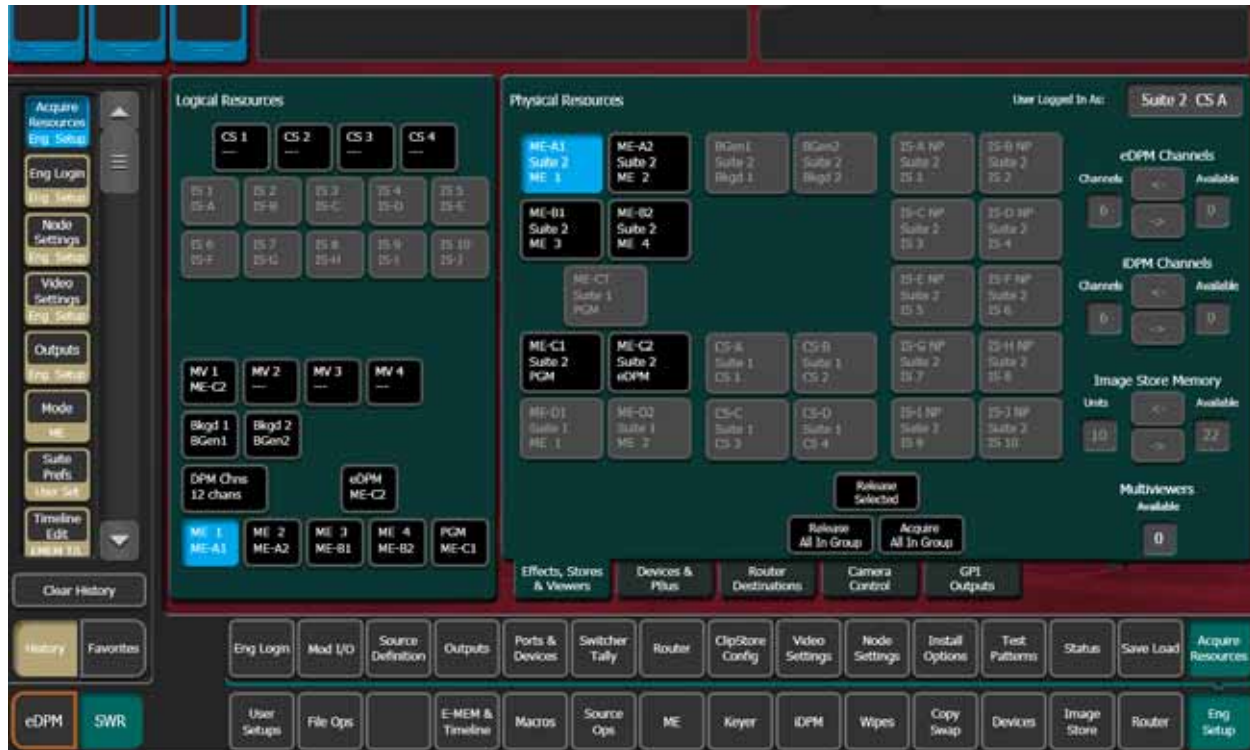

## Save Default Multi-Suite Engineering Setups File

Save this Eng Setup configuration to disk, naming the file to identify it as the default multi-suite engineering configuration for the facility.

## Define and Save Default Suite Prefs

Define default Suite Preferences as appropriate for suite 1 and suite 2. This is accomplished by logging in to each suite individually, accessing the various configuration menus, setting the available parameters, and then saving a Suite Prefs file for each suite while logged into that suite.

## Define and Save Default Panel Prefs

Similar to Suite Prefs above, Panel Prefs files can be created and saved for each control surface, if you wish. For engineering troubleshooting purposes, you may be able to define and save a single Panel Prefs file for use on any control surface.

To use different Panel Prefs for different control surfaces, create and save each Panel Prefs file while logged into that suite and control surface. This is necessary for button mappings on each suite's control panel.

## Multi Suite Independent Operation

Once configured with two suites, operators can work on each control surface completely independently from one another. Coordination will be required, however, to ensure the resources each operator needs are shared as necessary.

Operators should also test any E-MEMs, R-MEMs, or other items created or saved previously to be sure they work properly with their currently acquired resources.

## Engineering Login

A K-Frame system can be configured as two suites, with each suite having up to two control surfaces. The Eng Login menu is used to choose which suite and control surface the GV Switcher menu will interact with and control.

To access a different Suite or Control Surface (CS):

- 1 Select **Eng Setup, Eng Login**.
- 2 Select the **Change Identity** button. The **Suite** and **CS** buttons will then be available for selection. After selecting a different button, a warning message appears.
- 3 Select **Yes** to make the change, or **No** to cancel the change and retain the existing menu identity.

---

**Note:** Changing a menu's identity in this way is temporary. Reloading the menu application or rebooting the Menu Panel will restore the Suite and Control Surface identity defined in the Node Settings, Control Surfaces menu.

---



K-Frame system resources can be allocated to each suite. By default all system resources are allocated to suite 1.

## SetDef and MatchDef

The SetDef and MatchDef options permit line rate signal format conversion of selected K-Frame system outputs and inputs. SetDef output and MatchDef input conversion is licensed in groups of four. Connectors are active when the associated Modular I/O board is present and the license is enabled. Selecting a Modular I/O button, labeled M1, M2, etc., displays controls for either input or output conversion in the right-hand pane.

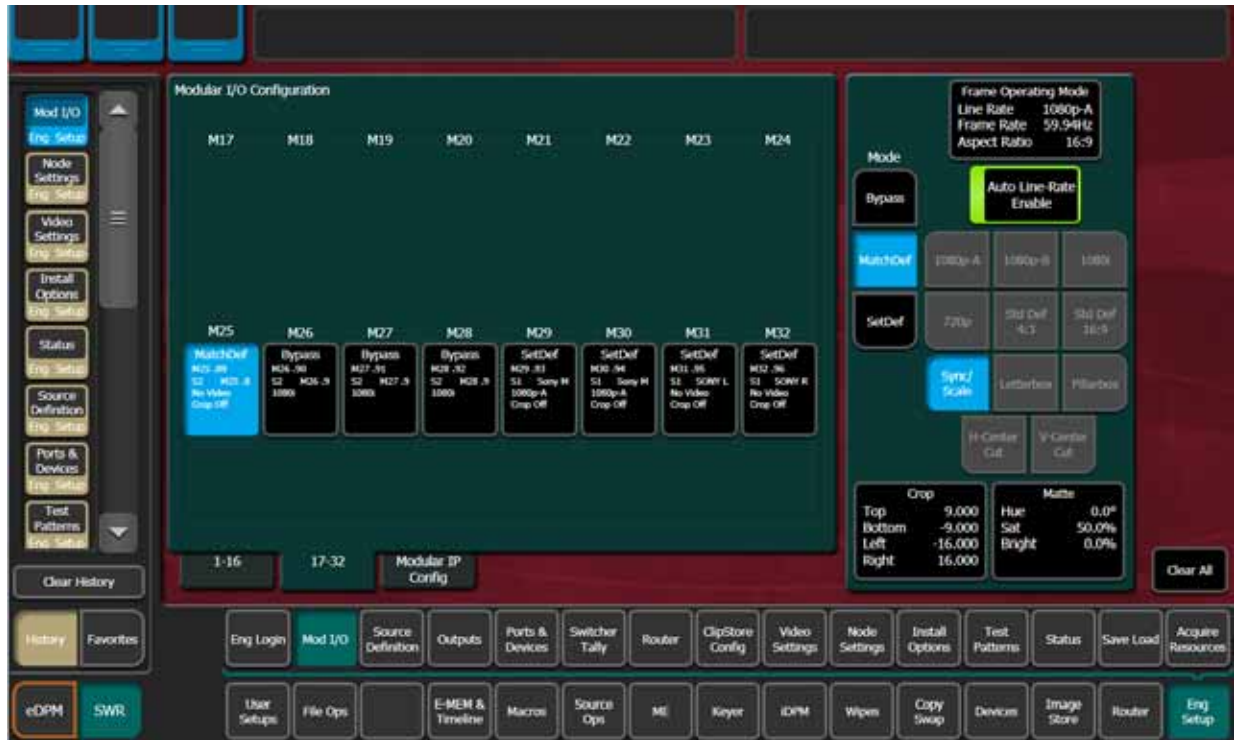

## SetDef Output Conversion

When SetDef Mode is selected, the Modular I/O buttons report the Mode, Engineering Name for the input, Suite 1 or 2 (S1 or S2), Output Name, output format and crop status (Off/On) for the output of the selected pair.

The currently operating video standard is shown in the **Frame Operating Mode** status display on the upper right portion of the menu.

The **SetDef Timing** button, when selected, displays Horizontal and Vertical Offset data pads, allowing changes to the timing of that output relative the system video reference.

The conversion format for the selected output is chosen from the labeled buttons in the right pane (**1080p-A**, **1080p-B**, **1080i**, **720p**, **Std Def 4:3**, **Std Def 16:9**). This format is applied to both output pairs.

Controls for Scale, Letterbox, Pillarbox, H-Center Cut and V-Center Cut are displayed, depending on the format selected.

**Sync/Scale** - Synchronizes the image then scales it to fill the full raster of the screen. If mismatched formats are involved, the image may distort and appear wider or narrower than its original state.

**Letterbox** - Used to convert 16:9 to 4:3 by adding bars above and below the image.

**Pillarbox** - Used to convert 4:3 to 16:9 by adding bars to the left and right sides of the image.

**H-Center Cut** - Fills the screen with the center portion of the image, cutting off some of the left and right sides.

**V-Center Cut** - Fills the screen with the center portion of the image, cutting off some of the top and bottom.

The **Crop** button, when selected, displays Top, Bottom, Left, and Right crop data pads. Crop values can be entered and activated by touching the **Crop Enable** button.

When Crop, Letterbox, or Pillarbox is active, the **Matte** button can be selected, which displays Hue, Saturation, and Brightness data pads. The color values entered are applied to the non-image portion of the raster.

## MatchDef Input Conversion

When MatchDef Mode is selected, the Modular I/O buttons report the current Mode, Engineering Name of the input, Suite 1 or 2 (S1 or S2), Output Name, input format and crop status for the input of the selected pair.

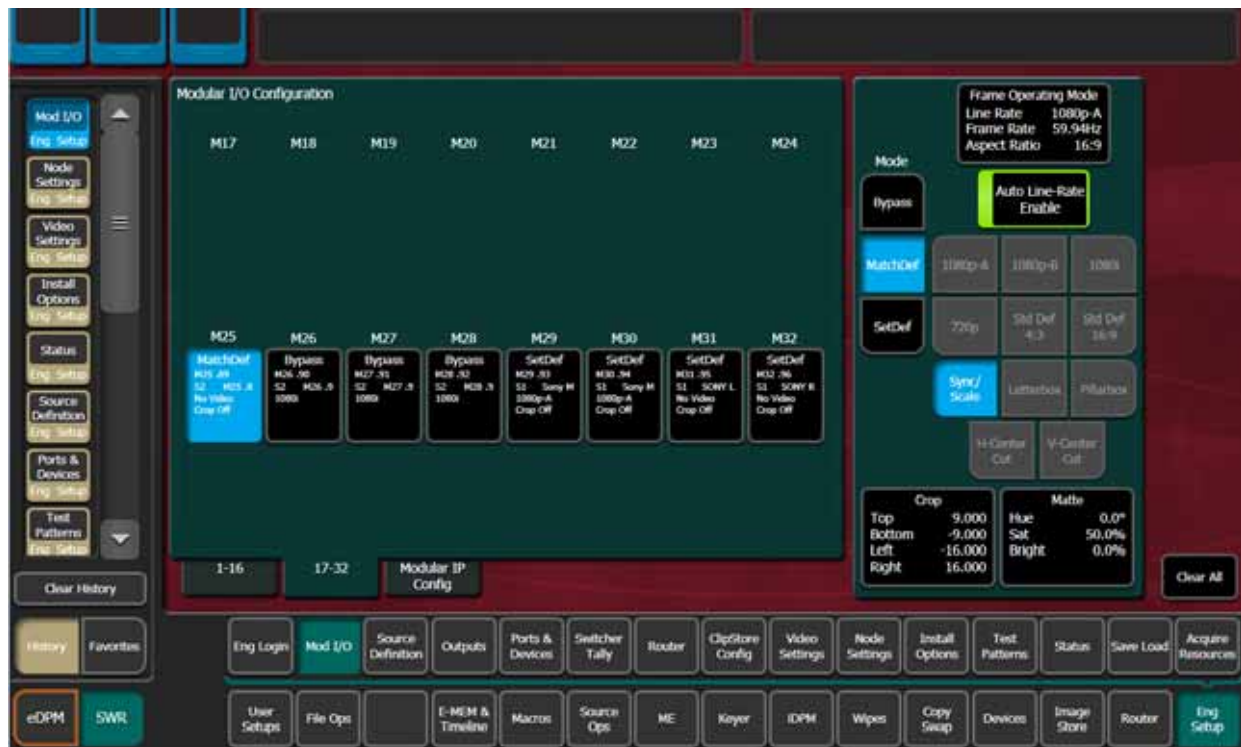

The currently operating video standard is shown in the **Frame Operating Mode** status display on the upper right portion of the menu.

**Auto Line-Rate Enable** – When on, the system detects the input video format and automatically chooses the appropriate line rate for the selected input. One frame of video is required for detection. If the incoming video signal format changes, one incorrect frame of video will be displayed. When Auto Line-Rate Enable is on, the Line Rate selection buttons below are inactive.

---

Note: If the incoming source is has a noisy signal, choosing the correct frame rate manually may provide better performance.

---



When Auto-Line Rate Enable is off, the conversion format for the currently selected input can be chosen from the Line Rate selection buttons in the right pane (**1080p-A**, **1080p-B**, **1080i**, **720p**, **Std Def 4:3**, **Std Def 16:9**).

Controls for Scale/Sync, Letterbox, Pillarbox, H-Center Cut and V-Center Cut are displayed, depending on the format selected. These controls are identical to those used for SetDef. The **Sync/Scale** button behaves the same as the SetDef **Scale** button, but also employs frame sync circuitry.

The **Crop** button, when selected, displays Top, Bottom, Left, and Right crop data pads. Crop values can be entered and activated by touching the **Crop Enable** button.

When Crop, Letterbox, or Pillarbox is active, the **Matte** button can be selected, which displays Hue, Saturation, and Brightness data pads. The color values entered are applied to the non-image portion of the raster.

## Video Settings

The Video Settings menu reports the current system sync reference and status, allows selection of the Frame Operating Mode, and provides other system functions.

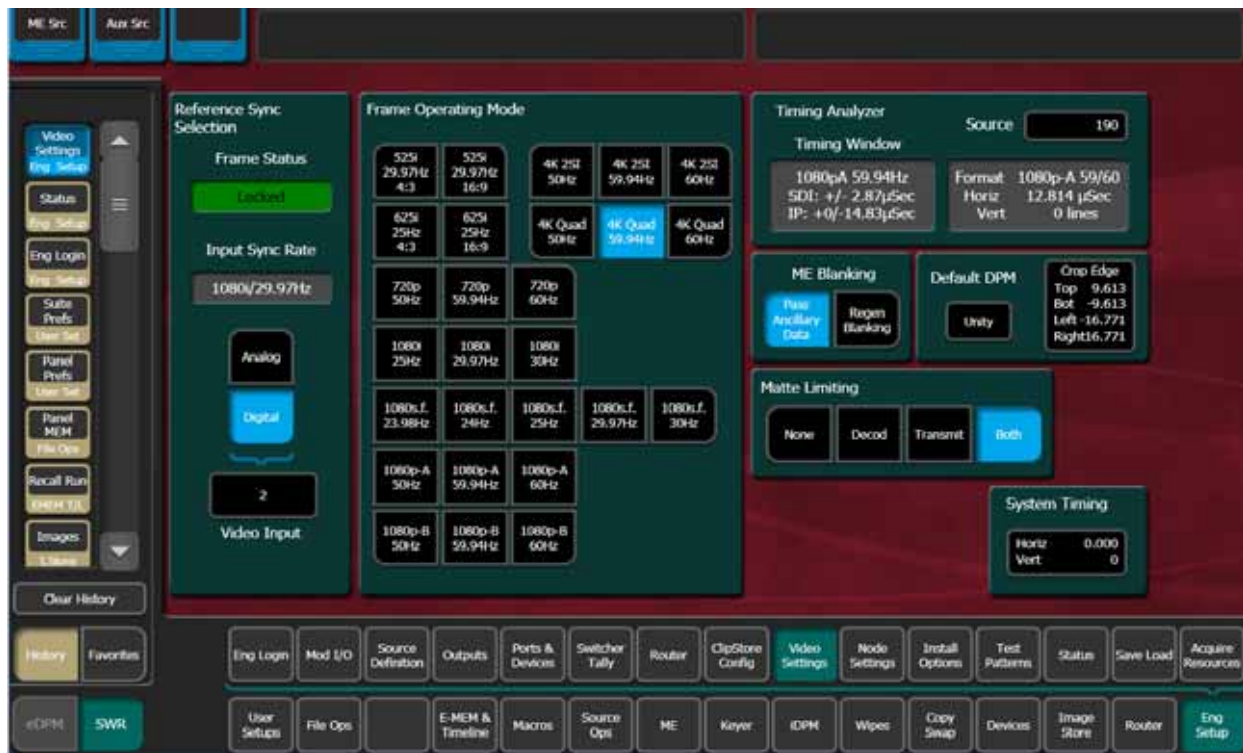

### Reference Sync Selection

Choosing **Analog** in the Eng Setup, Video Settings menu, selects the Analog Reference connector on the Video Processor Frame for system reference. Choosing **Digital** allows selection of a video input source for use as system reference.

Any interruption of an analog or digital reference source can cause K-Frame system problems.

**Frame Status** – Reports the current sync status of the frame (for example, Locked).

**Input Sync Rate** – Reports the current input sync reference format.

## Frame Operating Mode

The selected Frame Operating Mode determines the K-Frame's video input and output formats (excluding MatchDef and SetDef) and the internal processing used for the video.

## ME Blanking Settings

Production switchers normally regenerate a clean blanking interval. When the switcher must pass ancillary information such as embedded audio, this blanking regeneration can be disabled. The following settings apply to the output blanking of all the MEs.

**Pass Bus A's Ancillary Data** – Passes the ancillary data from the A bus to the ME Program output during the vertical interval.

**Regenerate Blanking** – Regenerates blanking during the vertical and horizontal intervals.

Regenerate blanking for MEs; no audio, subtitles, closed captioning, etc.

- 1 In the Eng Setup, Video Settings menu, Select **Regen Blanking** in the ME Blanking pane.

## Other Settings

### Matte Limiting

Matte Limiting determines how the matte generators produce colors. Limits can be imposed to prevent downstream signal problems.

**None** – In this mode, no limiting is imposed. Analog signal paths and monitors may behave poorly to some colors produced in this mode.

**Decodable** – This limiter mode produces colors that decode to valid RGB components. Not all valid RGB colors can be transmitted in NTSC, however. Saturated colors near yellow and cyan over modulate an NTSC transmitter.

**Transmittable** – This limiter mode prevents over modulating an NTSC transmitter, but can produce colors which can not be decoded into RGB. For example, a 0% luminance blue produces negative green and red components.

**Both** – This limiter mode is similar to **Decodable**, except that maximum levels are reduced slightly around yellow and cyan to prevent over modulating an NTSC transmitter.

### Command Processing

These controls determine when commands (like source selections or the initiation of mixes or wipes) will be enacted by the K-Frame system (also known as field dominance). These controls can be useful for consistent match frame editing.

**Any Field** – The action will occur at the start of the next field, either even or odd. Use this setting if you are not going to edit the video output and want the fastest response.



**Even Field** – The action will always occur at the start of the next even field. This is probably only appropriate if your edit controller is set to edit in the middle of a frame.

**Odd Field** – The action will always occur at the start of the next odd field. This is the normal setting for almost all conditions, especially when the video output will be edited, and is compatible with most video editing systems that use the frame boundary for edits. This setting is essential, however, when controlling external devices like DDRs that execute commands only at the beginning of the frame.

### **Default iDPM Crop**

Default crops are intended to define the extent of a standard image for a facility. The Default iDPM Crop controls adjust cropping when individual iDPM channel crop is turned off. Individual iDPM cropping is used to adjust for variations in individual sources.

SMPTE RP-187 establishes recommended practices for standard image sizes (production aperture, clean aperture). If a facility conforms to these practices, the K-Frame system default values will be correct and no adjustment should be necessary. Changing the default crops is not recommended, unless absolutely necessary.

Unfortunately, not all video images have the transition to blanking (black) in exactly the same place. Normally, these blanking variations are hidden at the extreme edges of the picture and are not visible. If an image smaller than expected is transformed, however, black lines can occur at its edges, which are now visible because they have moved inside the visible picture area. If it is necessary to compensate for variations in your facility's nominal blanking, adjust the default crops so they just remove black edges on the facility's normal image.

The 4:3 and 16:9 aspect ratios have different default crops.

**Crop Edge** – Allows setting alternative cropping for iDPM processing.

**Unity** – Resets iDPM cropping to factory default.

### **Timing Analyzer**

The Video Settings menu also has a timing analyzer and system timing adjustments (see the *K-Frame User Manual*).

## **Node Settings**

The Node Settings menus are used to establish communications among various K-Frame system components. These important settings are not included in Eng Setup configuration files, to prevent accidental system communication failures if Eng Setup files are loaded incorrectly.

## **Frame Suite Nodes & ID Menu**

The Frame Suite Nodes & ID menu has fields to enter the IP addresses the GV Switcher menu application will use to communicate with the Video Processor Frame, Image Store, and the Control Panel whose DPOPs will affect this application's menu displays. A menu restart is required to make IP address changes take effect.

When connected, the currently defined names of these devices are displayed. These names can be edited from this menu, and will be sent to the device as soon as the new name has been entered. Subsequent connections to this device from this or another menu will show that edited name.



Note: Do not change device or suite names unnecessarily, as this could cause confusion to other K-Frame system users.

## Mapping Logical Remote Aux Panels

The Remote Aux Logical Map menu is used to assign Aux Buses for control by that Remote Aux Panel. Single Aux Panels can control one Aux Bus, while Multi-Delegation panels can have several Aux Buses be assigned to delegation buttons on that panel.

To Assign Aux Buses on a Multi-Destination Panel:

- 1 Select **Eng Setup, Node Settings** in the menu.
- 2 Highlight a Panel Delegation button at the top of the screen.
- 3 Select one of the Logical Aux Buses buttons on the lower screen. That Aux Bus will then be selected when that Remote Aux Delegation button is pressed on that panel.

## Remote Aux Button Mapping

The Remote Aux Button Map menu is used to configure sources to the Remote Aux Panel source select buttons.

To Map Remote Aux Panel Buttons:

- 1 Select Eng Setup, Node Settings in the menu.
- 2 Highlight a source select button in the central scrolling list.
- 3 Touch a source button on the scrolling list on the right. It will be assigned to that Remote Aux Panel button.
  - The **Source Number** data pad and scroll knob on the upper right can be used to quickly select a K-Frame source by its logical ID number
  - The **Lock** button at the bottom prevents the source list from scrolling when choosing different Remote Aux buttons.

## About the Status Menu



The Status menu reports the currently connected K-Frame devices by their name, control surface, type, IP address, software version, and date in the central window.

**Note:** The Control Surface of a Menu Panel indicated on this menu is defined by the Node Settings, Control Surfaces menu settings. It does NOT report the Control Surface that Menu Panel is currently logged in as.

**Menu Version** – Reports the version of the GV Switcher menu application.

**Memory Usage** – Reports the amount E-MEM and other keyframe memory currently in use. If usage reaches 100%, no new keyframes will be able to be added to any effect. Deleting keyframes from any effect will regain space.

**Capture Software Diagnostic Data** – This button provides a convenient method to save the current configuration files, E-MEM, Macro, and also any frame software diagnostics data files that may exist (see Diagnostic Data Collection below). If you need to contact Grass Valley for assistance about any software problems, the engineering team will want these files for efficient troubleshooting. The **Minimize Menu** button minimizes the menu application, revealing the Windows desktop. The **Exit Menu** and **Closedown Menu Computer** buttons perform those functions.

## Acquire Resources

The Acquire Resources menus are used to acquire and release K-Frame system resources when multiple suites are being used. Different menus are used for different resource types.

### General Procedure to Acquire Resources

- 1 Login to the suite.
- 2 Select the button of the Logical Device you wish to acquire a resource for. These are the left most buttons on the scrolling list on the left. The menu will automatically display the menu for that resource type on the right.
- 3 Select the button of the physical resource you wish to acquire on the right side of the screen.

If no resources are available, you may need to Login to the other suite, release the resource(s) you need, then return to the original suite and acquire them.

### Acquire Multiviewer Resources with a Standard Frame

Any available unused ME/VPEs (Video Processing Engines) can be allocated as Multiviewer outputs to external monitors provided a physical ME resource is present in the Frame and the Multiviewer is licensed. Up to four external multiviewer feeds are possible and can be acquired by one suite or split between suites, when licensed. For the Standard K-Frame, an additional dedicated Multiviewer resource (that does not use an available ME resource) named MX-MV is provided for use in either Suite 1 or Suite 2.

Prerequisite: The MX-MV Multiviewer physical resource is not allocated to another suite. If configuring additional Multiviewer outputs, unallocated VPE physical resources are available.

- 1 Select the **Eng Setup, Acquire Resources** menu buttons.

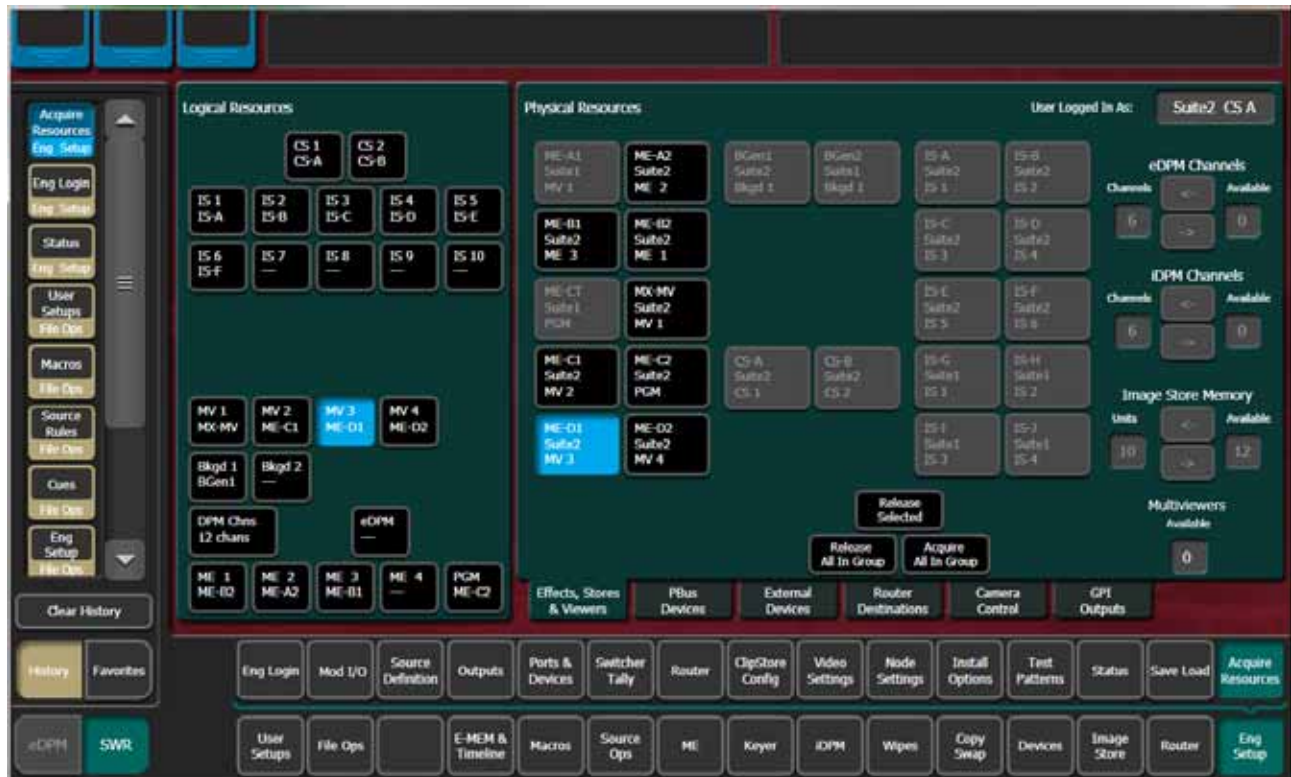

- 2 Select an **MV (MV 1—MV 4)** button from the Logical Resources pane.
- 3 Select an unallocated VPE resource in the Physical Resources pane to assign the Multiviewer.

Result: the physical resource is allocated for Multiviewer in the current suite.

The number of licensed Multiviewers is displayed in the lower right of the Acquire Resources menu; zero is displayed when all licensed Multiviewers are allocated.

If adding multiviewer resources in another suite:

- 4 Select the **Eng Login** menu category button.
- 5 Select **Change Identity**.
- 6 Select another suite identity.
- 7 Select **Yes** when prompted to continue.
- 8 Select the **Acquire Resources** menu button.
- 9 Select an MV (**MV1-MV4**) button in the Logical Resources pane.
- 10 Select an unallocated VPE/ME resource in the Physical Resources pane.

Configure outputs assigned to external monitors:

- 11 Select **Eng Setup, Outputs** in the menu.
- 12 Select an output assigned to an external monitor in the Physical Outputs pane.
- 13 With the **Fixed Sources** button selected (top right of menu) using the scroll bar or filter for the scrolling sources list, find and select one of the four fixed multiviewer sources, for example **Mview 4**.

Result: The currently selected Multiviewer layout is visible on the external monitor.

## Acquire Multiviewer Resources with a Compact (Six-Keyer) Frame

Any available unused ME/VPEs (Video Processing Engines) can be allocated as Multiviewer outputs to external monitors provided a physical ME resource is present in the Frame and the Multiviewer is licensed. Up to four external multiviewer feeds are possible and can be acquired by one suite or split between suites, when licensed.

Note: The MX-MV Multiviewer, a dedicated physical resource, is available on the Standard Frame only so it will be shown as NP (Not Present) in the Eng Setup, Acquire Resources menu for the Compact K-Frame. It cannot be acquired but shows created with the Compact K-Frame can be used on the Standard K-Frame where the MX-MV resource can be acquired.

Prerequisite: Unallocated VPE/ME physical resources are available.

- 1 Select the **Eng Setup**, **Acquire Resources** menu buttons.

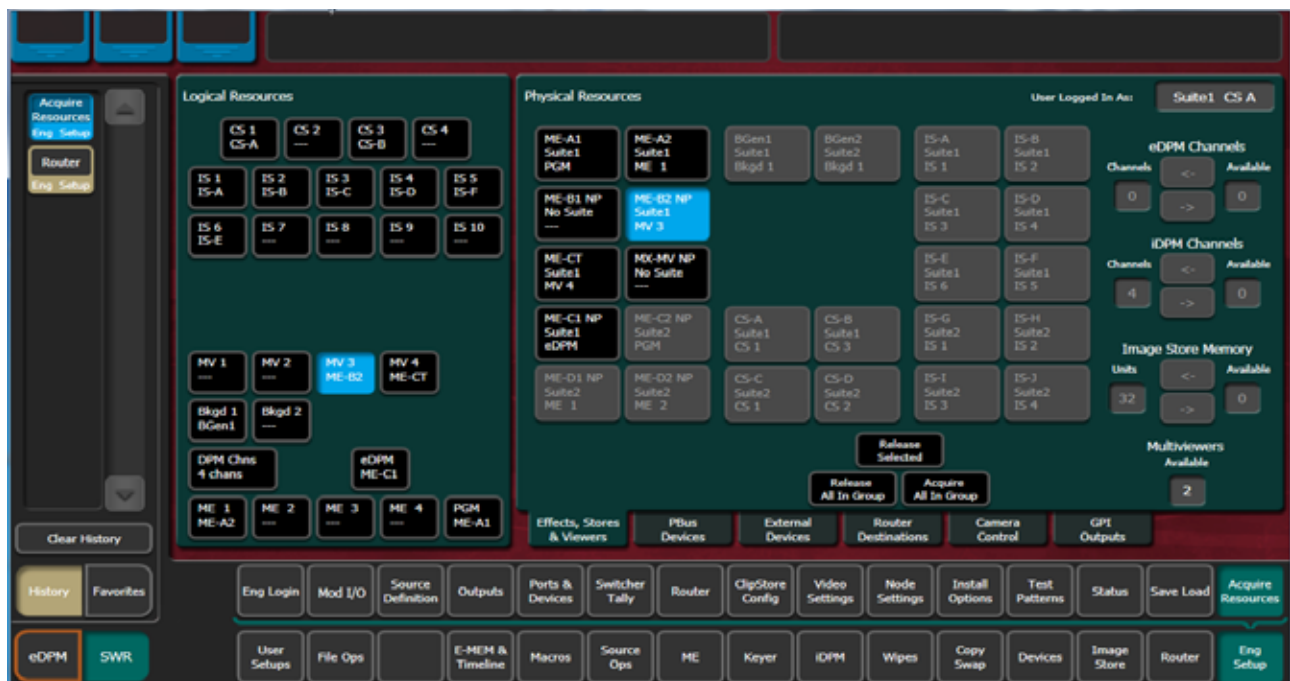

- 2 Select an MV (MV 1-MV 4) button in the Logical Resources pane.
- 3 Select an unallocated VPE resource in the Physical Resources pane to assign the Multiviewer.

Result: The VPE physical resource is allocated to Multiviewer in the current suite.

- 4 Select **Eng Setup**, **Outputs** in the menu.
- 5 Select the output assigned to an external monitor in the Physical Outputs pane.
- 6 With the **Fixed Sources** button selected (top right of menu) using the scroll bar or filter for the scrolling sources list, find and select one of the four fixed multiviewer sources, for example **Mview 4**.



Result: The currently selected Multiviewer layout is available to an external monitor.

If adding a second multiviewer display:

- 7 Select the **Eng Login** menu category button.
- 8 Select **Change Identity**.
- 9 Select another suite identity.
- 10 Select **Yes** when prompted to continue.
- 11 Allocate a second VPE physical resource in the Eng Setup, Acquire Resources menu as previously described.

## Acquire Multiviewer Resources with a Compact S-series (Four-Keyer) Frame

There are a pair of Multiviewers that can be licensed on the S-series Controller with pre-configured layouts and On-Air/Preview tally. Up to two external multiviewer feeds are possible and can be acquired by one suite or split between suites, when licensed.

- 1 Select the **Eng Setup, Acquire Resources** menu buttons.

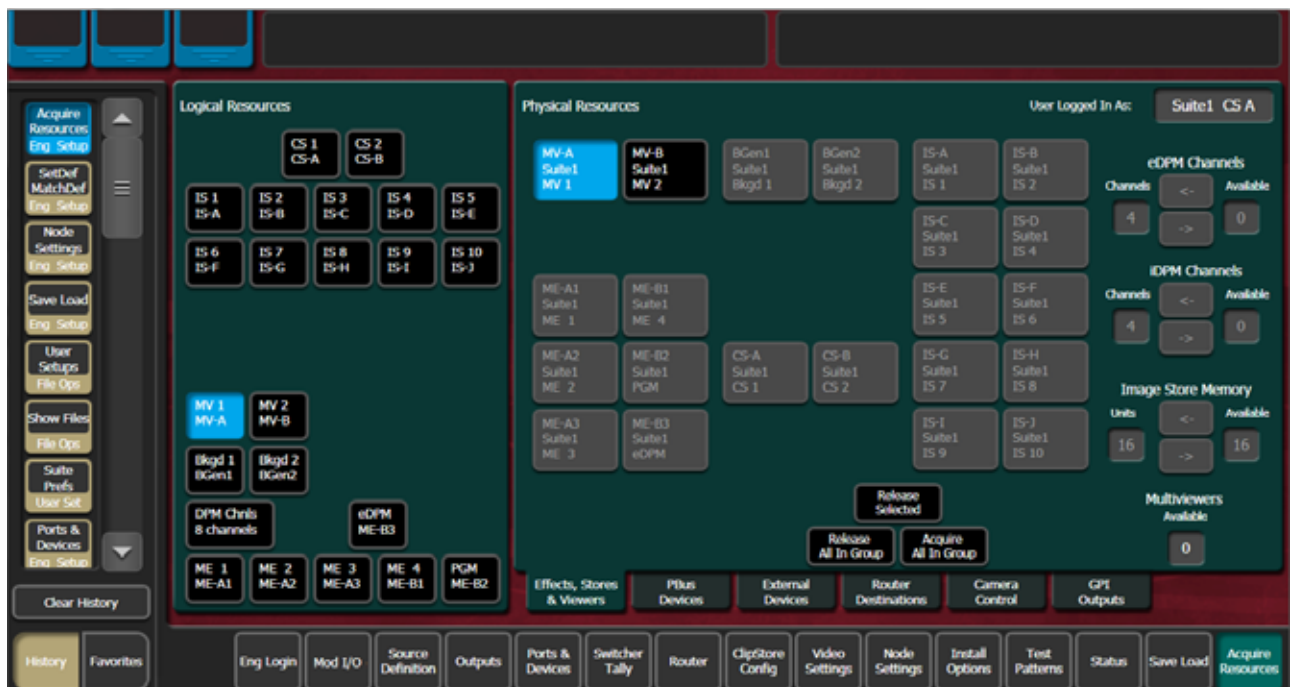

- 2 Select the **MV 1** or **MV 2** button in the Logical Resources pane.

Result: The Multiviewer physical resource is allocated to the current suite.

- 3 Select **Eng Setup, Outputs** in the menu.
- 4 Select the output assigned to an external monitor in the Physical Outputs pane.
- 5 With the **Fixed Sources** button selected (top right of menu) using the scroll bar or filter for the scrolling sources list, find and select one of the fixed multiviewer sources, for example **Mview 1**.

Result: The currently selected Multiviewer layout is available to an external monitor.

If adding a second multiviewer display:

## Basic Configuration

### Acquire Multiviewer Resources with a Compact S-series (Four-Keyer) Frame

---

- 6 Select the **Eng Login** menu category button.
- 7 Select **Change Identity**.
- 8 Select another suite identity.
- 9 Select **Yes** when prompted to continue.
- 10 Allocate a second Multiviewer physical resource in the Eng Setup, Acquire Resources menu as previously described.



# 6 External Interfaces

## Introduction

The K-Frame Video Production Center has that name because it is more than just a video switcher. For example, a K-Frame system is also able to control a variety of external devices.

Devices can be associated with sources, via source definition. Three types of source definitions for the K-Frame are available:

- **Direct** (used for standard video and key inputs, not for external interfaces),
- **Device** (used for DDR and VTRs). These devices can be controlled via Ethernet or serial port using various protocols. Each device uses a Device Definition that specifies the control mechanism.
- **Router** (used with an external routing system). This type permits the assignment of an external routing system destination to that source. Once assigned, different external routing system sources can be routed to that destination with the system. It is also possible to associate a router source to a device, to allow machine control of that source whenever it is selected on the K-Frame Control Panel.

Serial ports can also be used to control PBus configured external devices.

GPI outputs can be configured to provide relay closure control of hard-wired external devices from the K-Frame system.

In addition, external control of a K-Frame system is possible using GPI input connections, and by configuring an Editor with a serial port.

## General External Device Interfacing

In general, interfacing an external device to the K-Frame system involves the following elements:

- Control cabling and configuration (Ethernet, serial ports, GPIs).
- Video cabling (K-Frame input connectors).
- Creating an External Device Definition (for DDR, VTR, etc.) and assigning it to a source definition.
- Mapping that source to a Control Panel button.

Once configured, that external device can be selected as a source on the Control Panel. If a DDR or VTR it can be directly controlled from the System Bar, Device Control Module, Multi-Function Module, or from the K-Frame Menu Panel, as well as via EMEM.

PBus and GPI control of external devices is generally accomplished by the operator using EMEM. PBus and GPI triggers can be manually tested from the GV Switcher menu application, and Macros can be created to allow triggering using Control Panel buttons.

Routing System configuration with K-Frame involves establishing communications between the K-Frame and Routing control systems, assigning Router destinations to sources, and identifying which Router sources will be accessible to the system.

## Ports & Devices

Control ports, GPI outputs, External Device Definitions, Ethernet Tally and Editor Ports are configured with the Ports & Devices menus, accessed via **Eng Setup, Ports & Devices**, and then touching the appropriate tab.

### PBus Ports

The PBus Ports menu is used to configure serial ports for PBus control of external devices. Twenty four PBus devices are supported, which can be assigned to the same or different serial ports, using PBus addresses (0-23) when the same port is used for multiple devices.



**PBus Devices** – One of the twenty four available PBus devices can be selected on the upper left side of the menu. Once selected, the remainder of the menu is delegated to that PBus device.

**RS422 Port Select / Status** – The button for the port currently assigned to the selected item will be highlighted. Touching **None** clears the port assignment.

**Baud Rate / Parity** – Serial port settings are selected with these buttons. The **Set Default** button returns the settings to the K-Frame factory defaults.

**PBus Name** – Touching this button opens an alphanumeric keypad used to give the PBus device a descriptive name. These names appear on the separate Devices, PBus and PBus & GPI Enables menus, to help the operator identify each function.

**Set PBus Address** – Touching this button opens a keypad allowing entry of a PBus address, which is required if multiple PBus devices use the same port.

**Unassign PBus Device** – Clears the name of the selected PBus device and also clears its port assignment.

**Trigger Names** – Names can be entered for each of the 16 PBus triggers (0-15), by touching each button.

**Clear Names** – Removes the names from the currently selected PBus device.

## Copy Trigger Names

Trigger names can be copied from one PBus device to another.

- 1 Highlight the PBus device you wish to copy names from.
- 2 Select **Set Copy From** to enter that device in the adjacent window.
- 3 Highlight the PBus device you wish to copy the trigger names to.
- 4 Select the **Copy Names** button.

Once configured, PBus devices will be available to operators for use with EMEMs via the Devices, PBus menu.

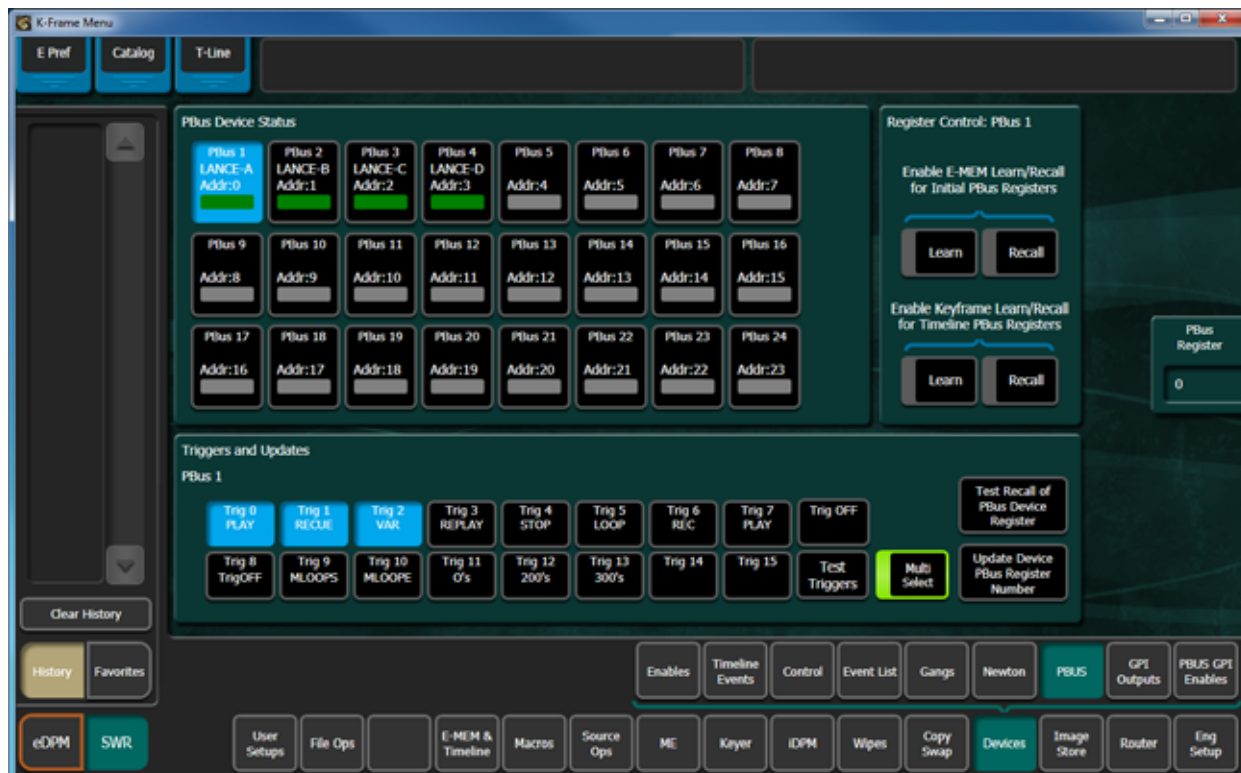

## GPI Outputs

The GPI Outputs menu is used to configure the K-Frame's GPI connectors. GPI outputs can be assigned to Suite 1 or Suite 2 using the Eng Setup Acquire Resources menu.



**GPI Outputs** – The buttons in the scrolling list represent the physical GPI output relays available on the system. The functions performed by these relays depend on how they have been connected to the device being controlled. One output can be selected at a time.

**GPI Name** – Touching this button opens an alphanumeric keypad used to give the GPI Output a descriptive name. These names appear on the separate Devices, GPI Outputs and PBus & GPI Enables menus, to help the operator identify each function.

**Duration** – Sets the duration the relay will be closed, in video frames.

**Test GPI** – Touching this button triggers the selected GPI.

Once configured, GPI Outputs will be available to operators for use with EMEMs on the Devices GPI Outputs menu.



## PBus and GPI Enables

PBus and GPI Output functionality (communications) can be enabled and disabled by an operator from the Devices, PBus and GPI Enables menu. This menu has two tabs, one for PBus, and the other for GPIs. When items are disabled on these menus, EMEM or Macro programmed PBus and GPI Output triggers will be inactive when the EMEM or Macro is run.



External Interfaces  
PBus and GPI Enables



## External Devices

The Eng Setup External Devices menus are used to create and edit Device Definitions. Different menus are displayed depending on whether a serial or Ethernet control type of device is selected.

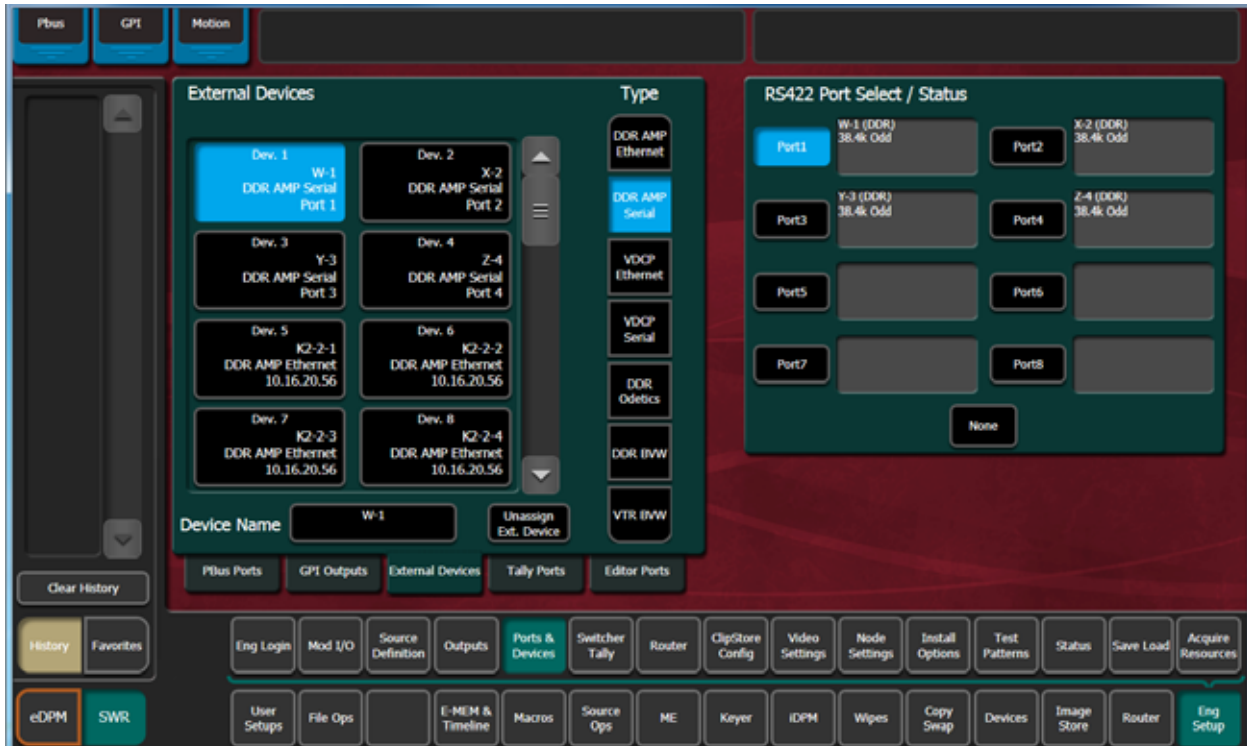

## External Interfaces VDCP Ethernet

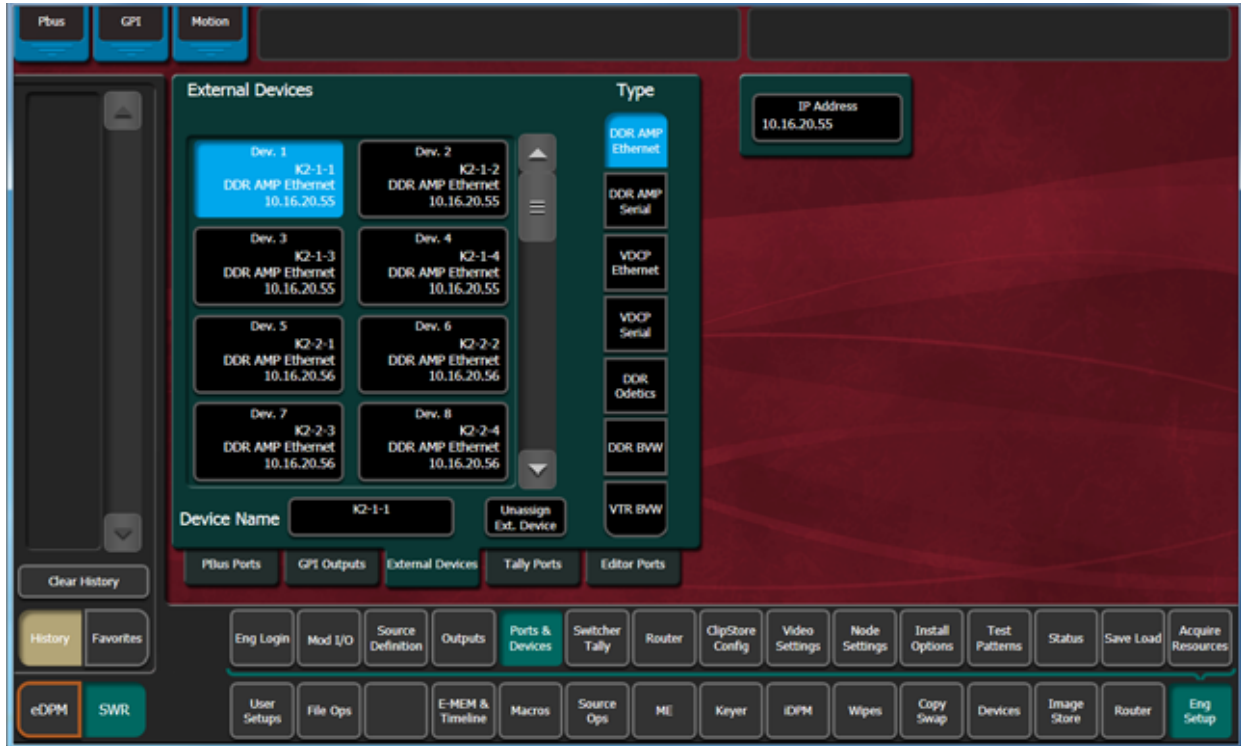

## VDCP Ethernet

When VDCP Ethernet is selected, additional parameters are available.



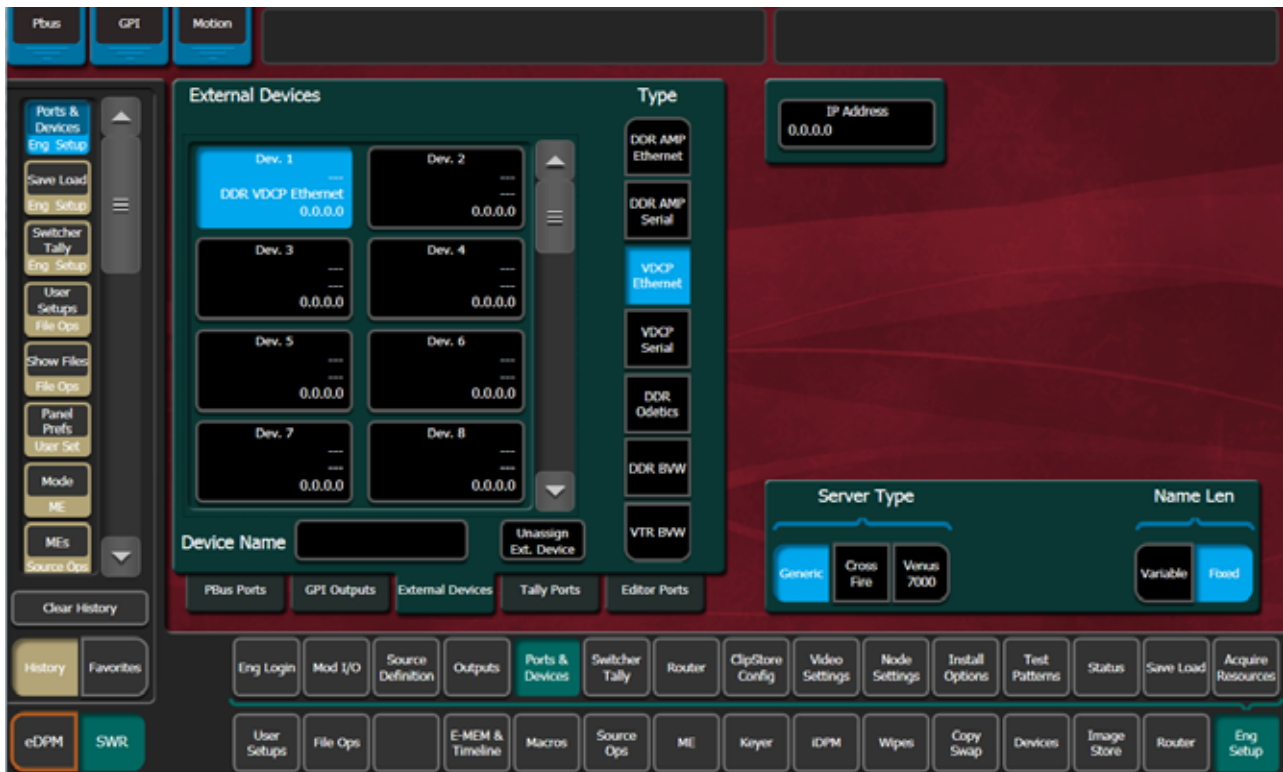

### Server Type

- Generic
- CrossFire
- Venus 7000

### Name Length

- Variable
- Fixed

## VDCP on Ethernet Configuration

For Ethernet VDCP, the user must specify the IP Address of the device they are connecting to, in the Eng Setups/Ports & Devices/External Devices menu.

When configuring a device to connect to the K-Frame with Ethernet VDCP, the device should be configured to use port 8000. The one exception to this is when the Server Type is CrossFire. When the Server Type is CrossFire, the device should be configured to use port 8000 plus the Device number. For example, if Device 7 in the External Devices menu is configured to use Ethernet VDCP with a server type of CrossFire, the CrossFire device should be configured to accept the connection on port 8007.

## Device Definition

The K-Frame system uses a software External Device Definition object to define the capabilities of each device interfaced with the system.

Use the Ports & Devices menu to define external devices.

External Device Definitions contain the interface information required for that external device, (e.g., IP Address or Serial Port). Each Device Definition is given a unique name. Once a Device Definition has been created for a device (DDR, or VTR), it can be assigned to a source. That source then supports the specific capabilities of that external device. (PBus and GPI configurations are different, and are not associated with a particular source.)

Selecting an already defined item in the scrolling External Devices list on the left brings up information for that device and delegates the rest of the menu to that object.

**Device Name** – Touching this button opens an alphanumeric keypad used to give the External Device a descriptive name. These names appear in the Control Panel System Bar and GV Switcher menus.

---

Note: When configuring servers with multiple channels, the channel number must be appended to the device name with a - character, and the base name be the same for all channels on the same server (e.g. 'Vdr4-1', 'Vdr4-2', etc.).

---

**Type** – Chooses a control protocol for the currently selected device.

- For Ethernet devices, and IP address field is available for entering the IP address of the External Device.
- For serial control devices, selecting a Port button on the right assigns the selected device to that port in the Ports & Devices, External Devices menu.

**Unassign Ext. Device** – Clears the definition of the selected item.

## Create an External Device Definition

- 1 Touch **Eng Setup, Ports & Devices, External Devices** to go to the External Device Definition menu.
- 2 Scroll through the list of devices on the left and select an available device.
- 3 Select **Device Name** and enter a descriptive name for the External Device.
- 4 Choose the control protocol for that device from the **Type** list.
  - If an Ethernet protocol was selected, enter the IP address for the External Device.
  - If a serial protocol was selected, choose the port the device will use.

When External Device Definitions have been created, the Source Definition menu lists them when the **Device Source Type** and **External Device** buttons are selected.

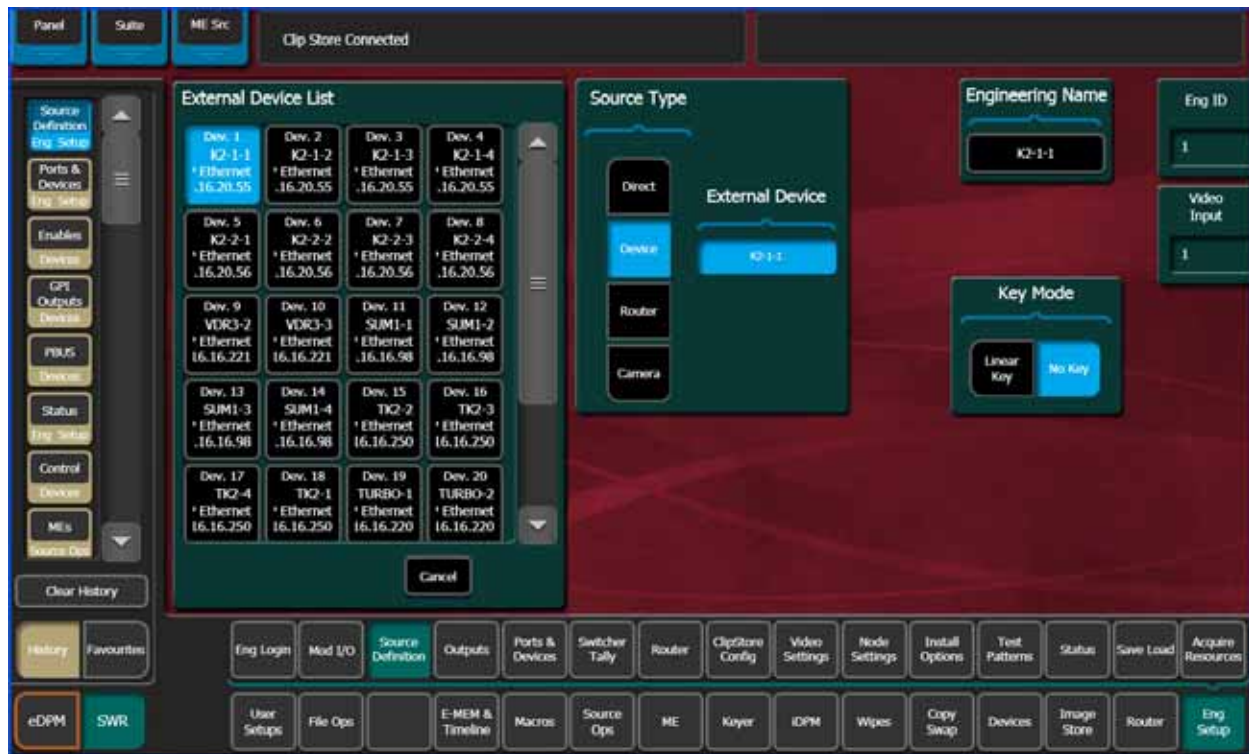

## Ethernet Tally Ports

There are three configurable Ethernet Tally ports. Ethernet tally port configuration can vary depending on your needs, for example two tally ports could be used for tally signal while the third is used for diagnostics. See the documentation that came with your Ethernet tally system for more information.

Additionally, tally is supported via GPO connections.

---

Note: Serial tally is not supported for K-Frame systems due to the vast amount of data being transmitted.

---

## Configure Ethernet Tally Ports

- 1 In the K-Frame menu, select Eng Setup, Ports & Devices, Tally Ports.



- 2 In one of the ports, select the IP Address data pad.
- 3 Enter the client IP Address in the pop-up keypad and select **Enter**.

## Editor Ports

Two editor ports can be configured and assigned to the K-Frame serial ports. Selecting an Editor button on the left delegates the rest of the menu to that item.



**RS422 Port Select / Status** – The button for the port currently assigned to the selected item will be highlighted. Touching **None** clears the port assignment.

**Editor Name** – Touching this button opens an alphanumeric keypad used to give the Editor a descriptive name.

**Unassign Editor** – Clears the selected serial port's assignment.

**Baud Rate / Parity** – Serial port settings are selected with these buttons. The **Set Default** button returns the settings to the K-Frame factory defaults.

## Router Interface

The K-Frame system can interface with an external routing system. A routing system connects a router source (router input) to a router destination (router output). Changing the router source sends a different signal to the destination (called a take). A router destination can in turn be connected to a K-Frame input and be configured as a routed source (called switcher source in this discussion and in the GV Switcher menus). The router acts as a pre-selector for the switcher source, and so increases the number of inputs available to a button on a K-Frame system bus.

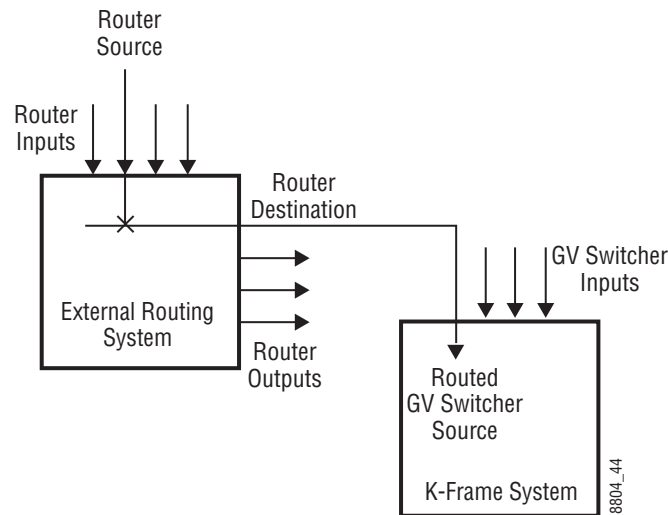

*Router Source, Router Destination, and Routed Switcher Source*

An external routing system can be configured into levels, to allow the switching of multiple signals simultaneously. For example, video signals can be organized on one level, and key signals on another. By specifying both levels when giving a router take command, both the video and key signals of a source will be routed to their destinations.

---

**Note:** K-Frame system router Take commands are only applied to all router levels. The external routing system's destinations must be configured with all router levels selected.

---

Router control panels can also protect router destinations from being changed by other control panels. A protected router destination cannot be changed by a different control panel, but may be changed by the panel that set the protection. Protections help prevent inappropriate router source changes. The K-Frame system can be considered a type of router control panel, and so the system can protect router destinations. The K-Frame system router protect commands are applied to all router levels.

## Router Source Name Changes (at the Router) and GV Switcher Updates

When an NV9000, Encore, or other supported router is connected to a GV Switcher system using Grass Valley's Native Protocol (SMS 7000), and router source names are changed, the system and menu will now be updated automatically, with a few limitations.

The following areas of the GV Switcher system will continue to require a manual update for a router source name change:

- R-MEMs—Learn a new R-MEM in the Router, R-MEM menu,
- Macros—Learn a new Macro in the Macro menu,
- Device Control configuration for router sources—Update the router source name in the Eng Setup, Router menu, and

- Switcher sources configured for router destinations—Update the Router Destination source name in the Eng Setup, Source Definition menu.

**CAUTION:** If these areas of the system are not manually updated, the router source may behave unexpectedly or no longer work.

## Features

- Interfaces to the Grass Valley SMS 7000, Encore, and other routing systems via Native protocol.
- K-Frame system configuration of routed K-Frame sources.
- Names of router sources are shown on the K-Frame Control Panel and K-Frame Menu Panel displays.
- Router source selection control via the K-Frame Control Panel and K-Frame Menu Panel displays.
- Protection types (None, Protect, and On Air).

## Control Interface Cabling

Connect an Ethernet cable from a K-Frame system Ethernet switch to the external routing system Ethernet network. The system can communicate with devices on different networks via a gateway router. If a gateway router is not used, the external routing system must be on the same subnet as the K-Frame system.

## Video Interface Cabling

Connect each external routing system destination to an available input connector on the K-Frame Video Processor. You will need to know the input connector number used for each destination when you configure the K-Frame source.

## External Routing System Configuration

It is assumed the external routing system has already been configured for basic use in your facility, and only needs to be re-configured to interface with the K-Frame system.

## Setting IP Addresses

The Eng Setup Router menu is used to set the IP Address(es) the K-Frame system will use to communicate to the external routing system. The external routing system can have an optional redundant, or secondary, controller which takes over should the primary fail. Both router control systems will require their own IP address settings.

- 1 Select **Eng Setup, Router**.



The **Status** indicator is red when communication is not detected, and goes green when communication is established.

To Set the IP Addresses:

- 2 Select the **Primary IP** data pad and enter the primary address of the router with the pop-up keypad.
- 3 Select the **Secondary IP** data pad and enter the secondary IP address of the router, if appropriate. If the router has only one control system, leave this address set to the blank default.

---

**Note:** If the K-Frame system has been configured with a router IP address but a connection to the router has not been established, changing the IP address in this menu will not make the K-Frame system immediately try to connect to the new router address. The K-Frame system will automatically try to connect after about 30 seconds using the entered router IP addresses.

---

## Primary and Secondary Router Communications

The K-Frame system will initially use the primary router IP address for communications. If the primary control system fails to respond, the system will attempt to use the secondary IP address for router communications, and if successful will continue using it in the future. If communications then is lost to the secondary control system, the system will attempt to reestablish communications with the primary router control system.



## Define Routed Source Definitions

The Eng Setup Source Definition menu is used to define routed K-Frame sources, which includes specifying which router destination will be associated with each switcher source.

- 1 Select the **Eng Setup, Source Definition** in the menu.
- 2 Select the source to be configured with the router on the left scrolling list.
- 3 Select the Video Input data pad and enter the number of the input that will be used with the router video destination.
- 4 If the routed source will have an associated key signal, touch the appropriate Key Input button, then touch the Key Input data pad and enter the number of the input that will be used with the router key signal destination.

---

**Note:** If you assign a key input, the router system needs to be configured to switch that key destination along with the video destination. Router levels can be used to accomplish this.

---

- 5 Touch the **Router** type button to identify it as a routed source.

---

**Note:** The adjacent status indicator is green when a router is detected, and red when there is no response. If red, you should check the K-Frame or router system configuration or the physical Ethernet connections.

---

- 6 Touch the **Router Destination** data pad to open the Router Destinations menu. The K-Frame Video Processor receives a list of destination from the router and displays them on scrolling list on the left.



- 7 Touch the button for the desired destination to assign it to the previously selected router source.
- 8 Complete the source definition by entering an engineering name using the standard source definition procedure.

## User Setups

Once a K-Frame routed source has been defined, it can be mapped to source buttons using the standard button mapping procedure (User Prefs), and given alternate names (Suite Prefs, Source Patch menu). See the *K-Frame User Manual* for more information.



# Maintenance

## **Introduction**

This section provides routine maintenance information for servicing the K-Frame Video Production Center.

## **Servicing Precautions**

Before performing any type of K-Frame system maintenance or troubleshooting, read the complete Important Safeguards and Notices section at the front of this manual.

## **Grass Valley Web Site**

Visit the Grass Valley website for documentation, software updates, online support (including FAQs), spare parts information, and a link to the File Transfer Protocol (FTP) site.

## **Grass Valley Customer Support FAQ Database**

Answers to many common questions can be found by searching the Grass Valley Customer Support Frequently Asked Questions (FAQ) database, available on the Grass Valley web site.

## **Video Processor Frame Reset Procedure**

A Video Processor Frame reset button is located near the center of the front edge of the Controller Board, accessed by opening the front door of the Frame. The 13-RU and 6-RU Frames use the same type of Controller Board. Pressing this button will reset both the Video Processor CPU and the Image Store Processor CPU. Powering the unit off and back on also resets the Video Processor Frame.

Maintenance  
 Panel Control Unit (PCU) Reset (Kayenne only)

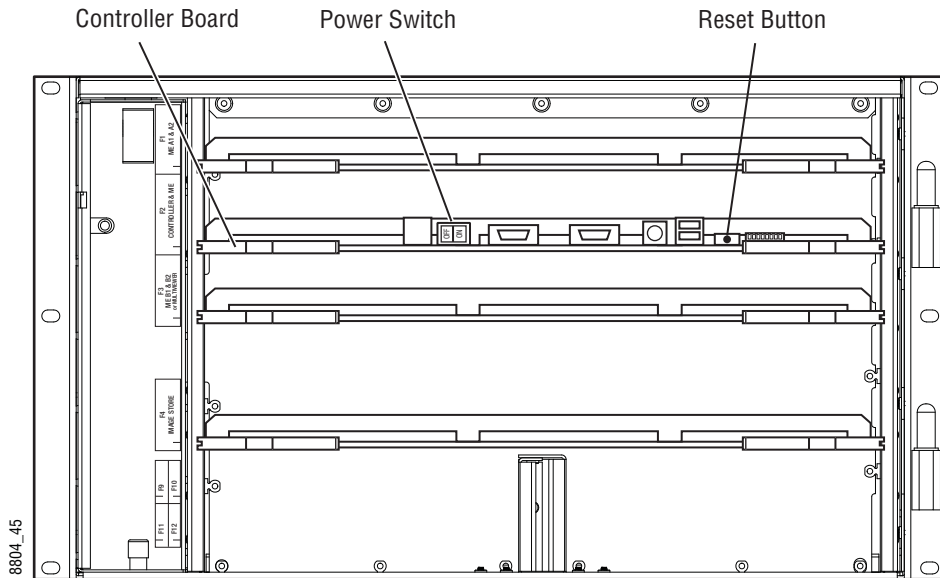

6-RU Video Processor Frame Reset Button and Power Switch

**Panel Control Unit (PCU) Reset (Kayenne only)**

The PCU has up to three reset buttons, one for the Control Panel Processor, one for the standard Menu Panel, and one for the optional second Menu Panel. These controls are accessible by opening the front door of the PCU Frame. Powering the unit off and back on also resets all installed components (Panel and Menus).

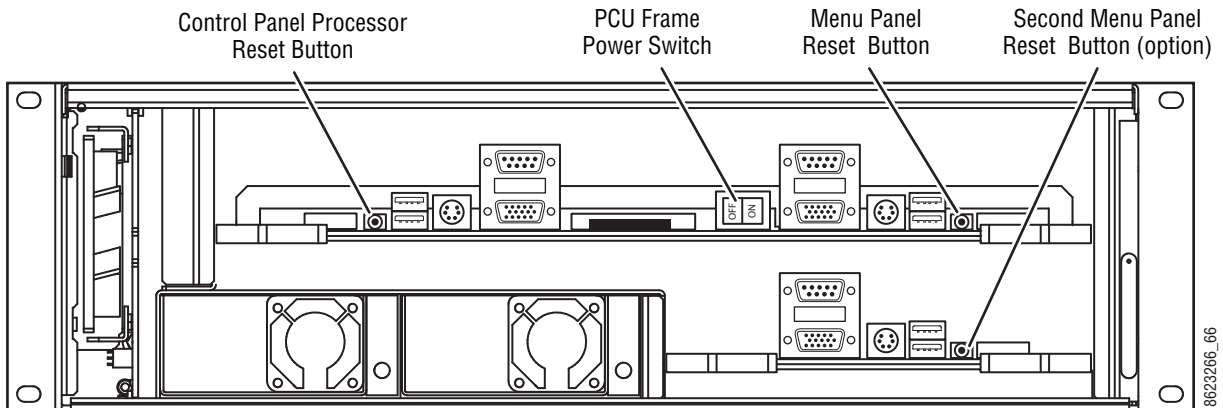

PCU Reset Buttons and Power Switch

Control Panel Adjustments

## Kayenne Control Panel Adjustments

### Kayenne Lever Arm Calibration

Press the **Exchange ME** (the left-most graphic symbol button over the Lever Arm), **Ptn Limit**, **EMEM Run**, and **Trans Rate** buttons simultaneously (in any order) to enter calibration mode for that module. Follow the instructions displayed, moving the fader to the bottom and top limits and pressing the **Auto** button. When done, press the **Key Prior** button to exit calibration mode.

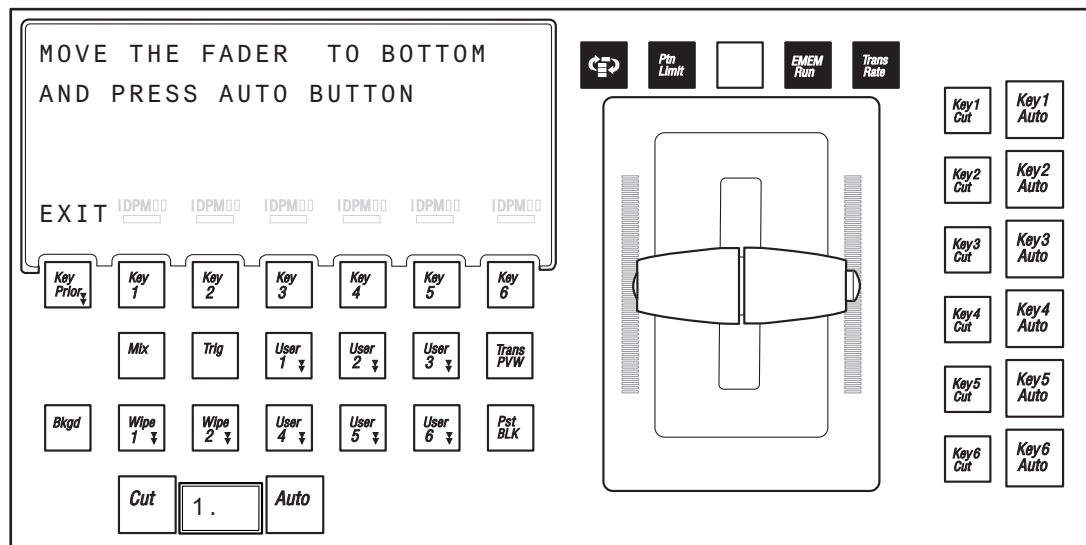

Button Hold Down for Lever Arm Calibration

Calibration settings are saved with the module. Disconnecting, reconnecting, or moving the module to a different location on the Control Panel (including a different Stripe) should not affect the calibration for that module.

### Calibrating the Joystick

- 1 Press the **Home** button to take the Multi-Function module to its Home state.
- 2 Hold down the two bottom outside buttons below the Joystick and press the **Key 1** button on the upper left to put the module into Calibration mode.
- 3 Follow the instructions displayed, rotating the Joystick and pressing the bottom right button labeled **NEXT**.  
Result: The **NEXT** button label changes to **END**.
- 4 Press the **END** button to complete the calibration and return the module to its Home state.

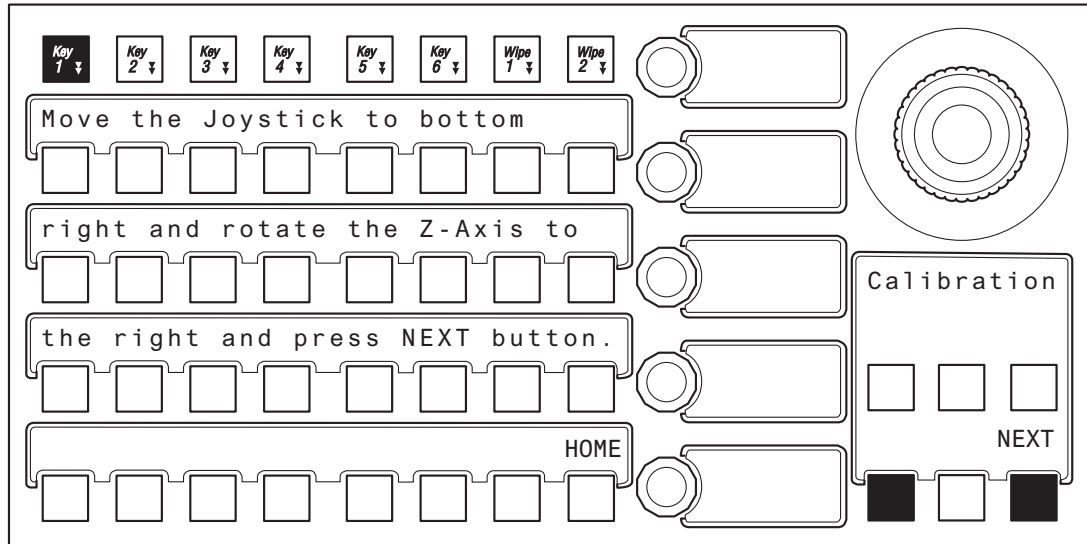

Button Hold Down for Joystick Calibration

Calibration settings are saved with the module. Disconnecting, reconnecting, or moving the module to a different location on the Control Panel (including a different Stripe) should not affect the calibration for that module.

## ME Stripe Mapping

The recommended PCU port to Stripe multi-pin cable connection order uses the following conventions:

- Lowest PCU Port > Top ME Stripe (under Local Aux Stripe if present)
- Next PCU Port > Next lower ME Stripes in order
- Highest contiguous PCU Port > Local Aux Stripe
- Stripes in the same Suite should use contiguous PCU ports.

By following these cabling conventions, troubleshooting will be easier because the connections will be consistent.

It is possible to re-map ME Stripe to PCU port connections. This can be useful if an essential ME Stripe (for example, the one with the Multi-Function Module) fails due to a multi-pin cable problem. That essential ME Stripe can be re-assigned to a different PCU port that has an operational multi-pin cable, restoring Kayenne Control Panel operation.

To remap ME Stripes, on any Transition Module press the three right-most buttons over the Lever Arm at the same time to enter ME Stripe Mapping mode.

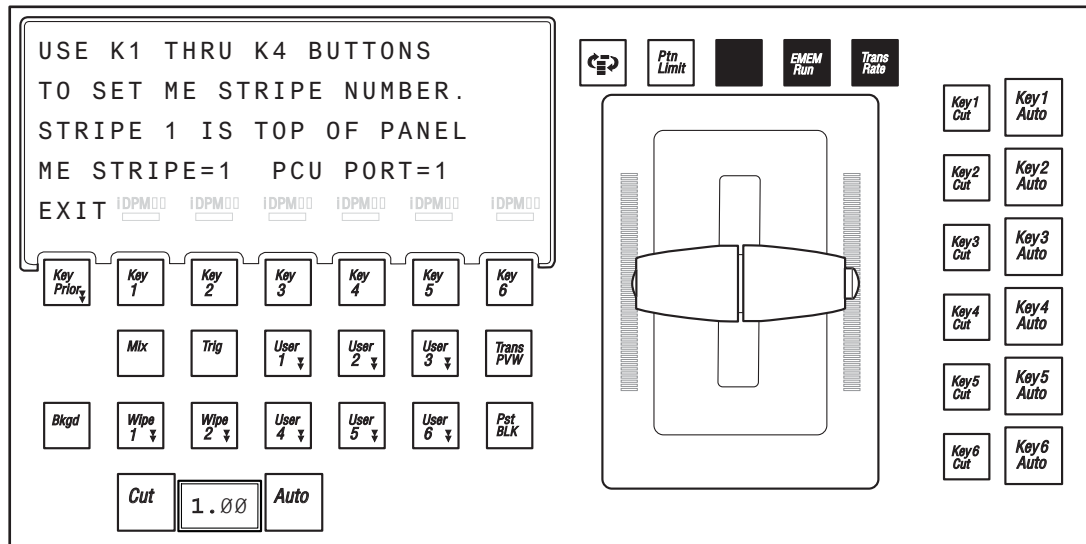

Button Hold Down for ME Stripe Mapping

On the ME Stripe you wish to remap, press a **Key 1** through **Key 6** button on the Transition Module in that Stripe to choose a PCU port for that Stripe. If that PCU port is used by another Stripe, it will be swapped.

When the Stripes are remapped, press the button labeled EXIT (**Key Prior**). The display informs you that mapping changes take place after reboot, and a with a Reboot Now prompt appears. Pressing the button labeled YES will reboot the Panel.

## Karrera Control Panel Adjustments

### Lever Arm Calibration

- 1 On any EMEM area, press **Menu, Page**. This shows a list of menu items that are selected with the buttons below the display (on the left).

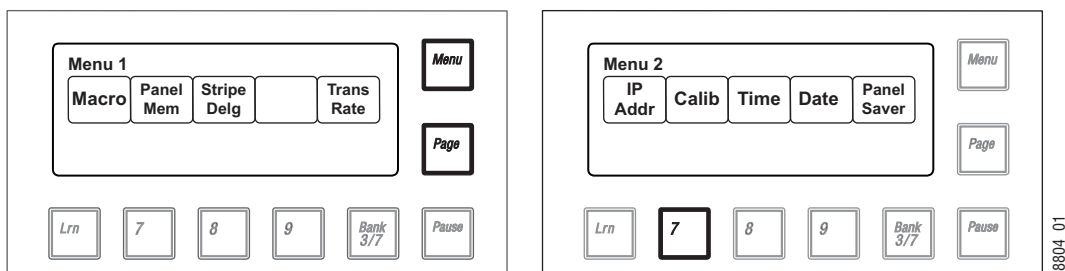

Karrera Calibration Menu, EMEM Area

- 2 Select **Calib** (press 7) to enter calibration mode (on the right).

**Note:** Pressing the **Menu** button at this time exits calibration mode without making any changes.

- 3 Choose the ME Lever Arm to calibrate. Lever 1 is the topmost Lever Arm on that panel. For example, to choose the second Lever Arm select **Lever 2 (8)**.

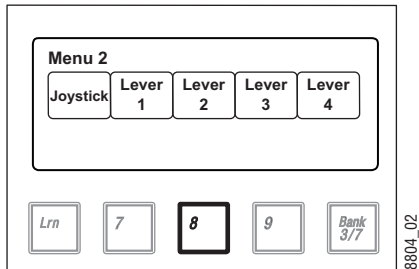

*Karrera Lever Arm Selection, EMEM Area*

- 4 On the chosen ME's Transition Area, follow the instructions displayed.
- Move the Lever Arm down all the way and select **Next** (press **Key Prior**).
  - Move the Lever Arm up all the way and select **Next** (press **Key Prior**). This saves the calibration values and exits calibration mode.



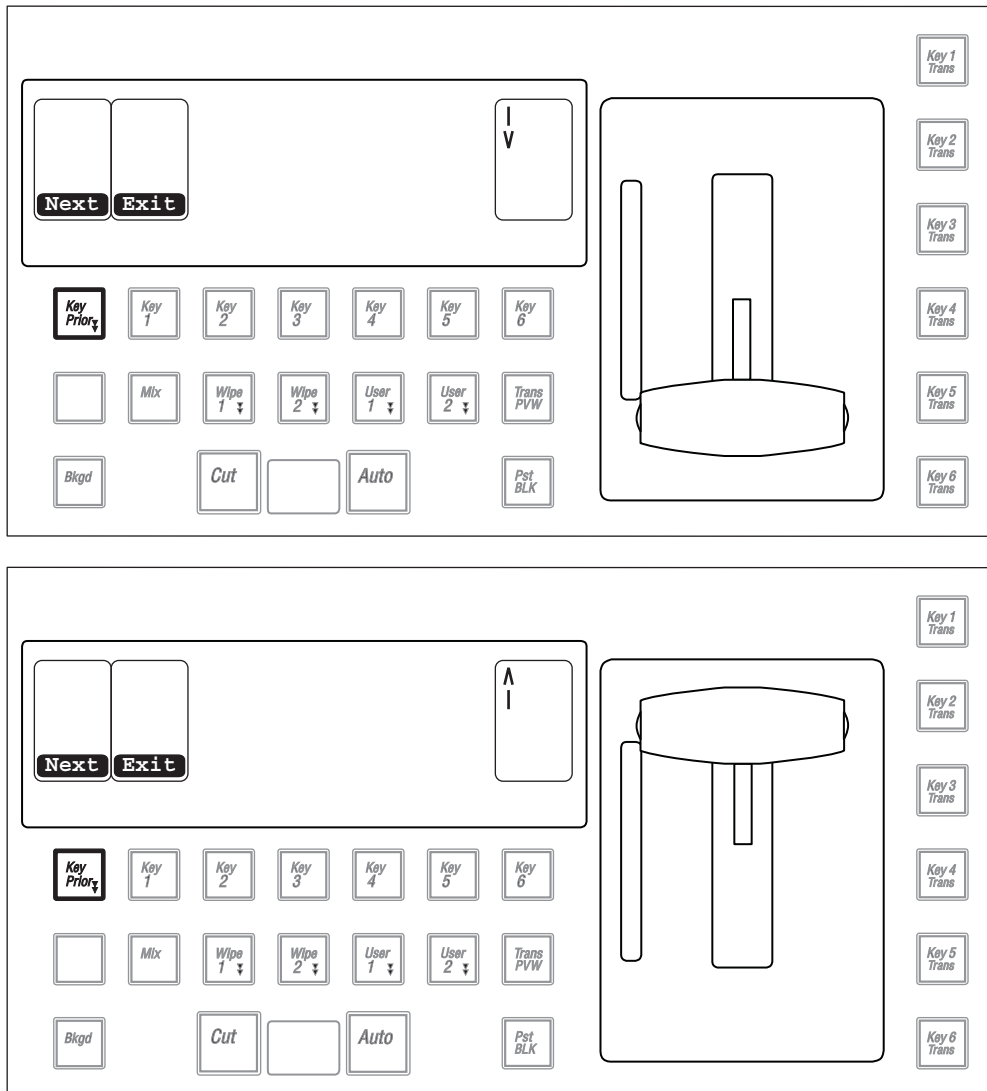

8804\_03

*Karrera Lever Arm Calibration Procedure, Transition Area*

**Note:** Selecting **Exit** (pressing **Key 1**) cancels the Lever Arm calibration mode and returns that Transition Area to transition operations, but may leave the Lever Arm in an un-calibrated state. Complete the entire calibration procedure to ensure normal operation.

## Karrera Joystick Calibration

- 1 On any EMEM area, press **Menu, Page**. This shows a list of menu items that are selected with the buttons below the display.
- 2 Select **Calib** (press **7**) to enter calibration mode.
- 3 Choose the **Joystick** to calibrate (press **Lrn**).

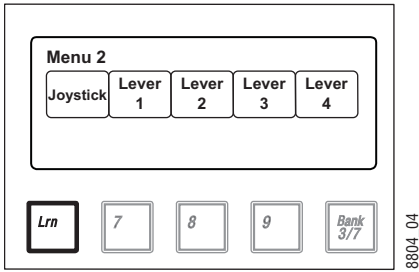

Karrera Joystick Selection, EMEM Area

- 4 Three buttons near the Lever Arm will blink, indicating Joystick actions are required.

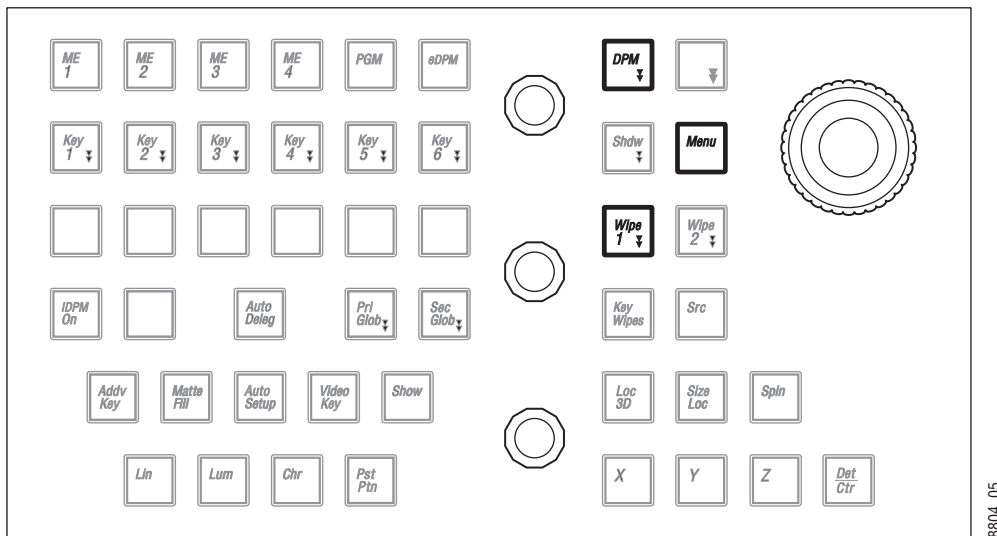

Joystick Calibration Indicator Buttons, Modifier Area

- 5 Follow the joystick calibration instructions shown on the EMEM display.
- Move the Joystick to the top left corner, rotate it counter-clockwise, hold, and press **Lrn**.
  - Move the Joystick to the bottom right corner, rotate it clockwise, hold, and press **Lrn**.
  - Allow the Joystick to return to its center, unrotated position, hold, and press **Lrn**.

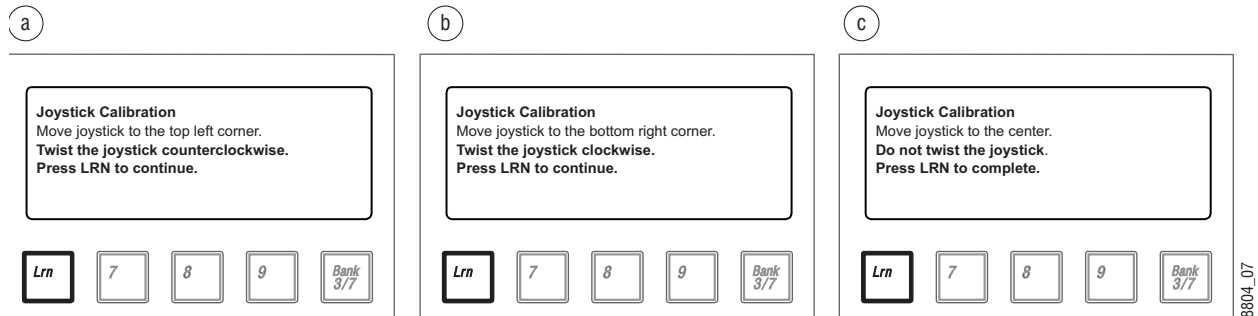

Joystick Calibration Instructions 2, 3, EMEM Area

**Note:** Pressing the **Menu** button cancels the Joystick calibration mode, but may leave the Joystick in an un-calibrated state. Complete the entire calibration procedure to ensure normal operation.

## Karrera Panel Saver Time Adjustment

- 1 On any EMEM area, press **Menu, Page**. This shows a list of menu items that are selected with the buttons below the display (on the left).

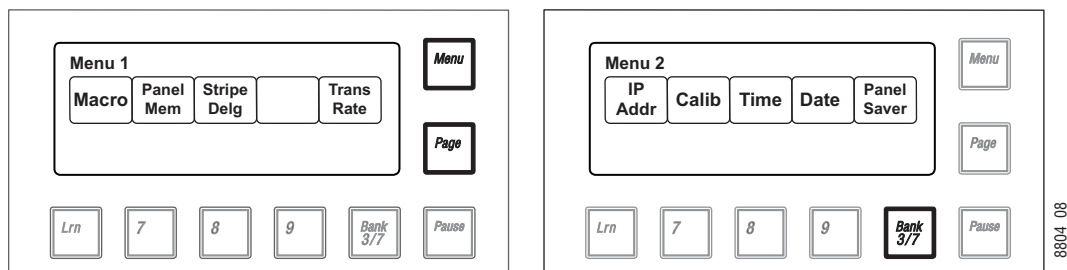

Karrera Calibration Menu, EMEM Area

- 2 Select **Panel Saver** (press **Bank 3/7**) to adjust the panel saver timing (on the right).
- 3 Once in panel saver mode, select the time period (in minutes) of inactivity required to initiate the panel saver mode using the buttons below the display. The illuminated button indicates the current setting.

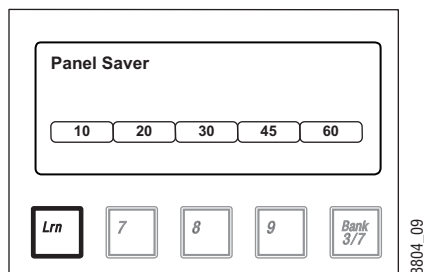

Panel Saver Mode, EMEM Area

## Kayenne and Karrera Touchscreen Calibration

The Kayenne and Karrera Touch Screen Menu Panels are adjusted in the factory before shipment, and so should not require calibration. If the Menu Panel does not respond correctly to screen touches, however, you can perform this procedure.

- 1 **Minimize** or **Exit** the menu application.
- 2 With the Windows desktop visible, click on **Start/Programs/Hampshire TSHARC Control Panel**. The Hampshire application will open.

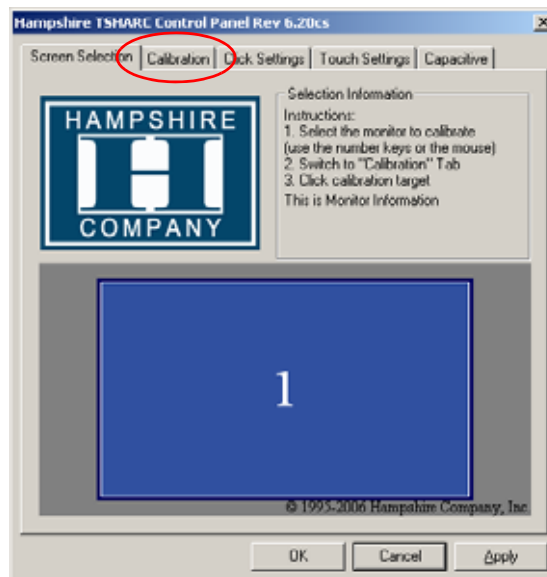

- 3 Select the second **Calibration** tab on the top to open that menu screen.

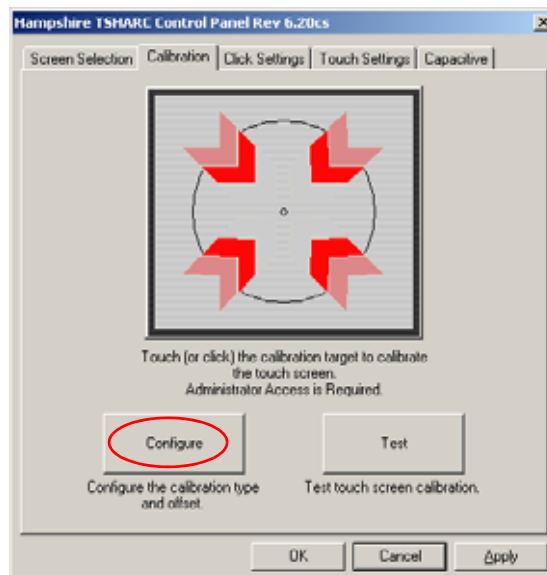

- 4 Touch **Configure** on the lower part of the screen to open a menu for selecting the calibration type.



5 Touch **4 Point Calibration** and then **OK**. You will return to the Calibration Menu screen.

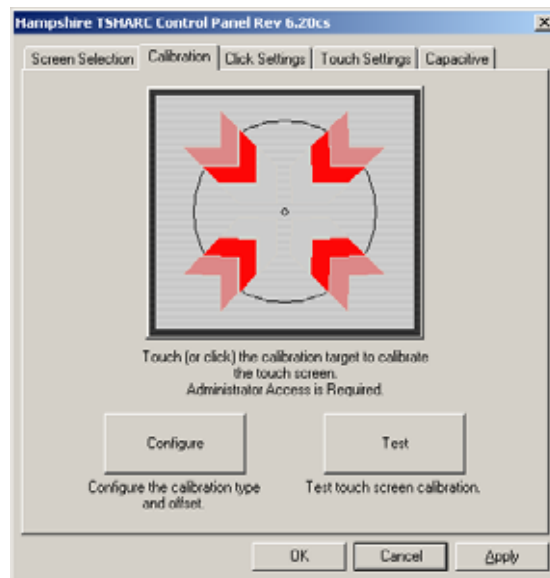

6 Start the calibration process by touching the center of the calibration box and circle where the red arrows are pointing.

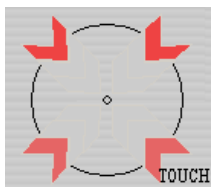

- 7 The Calibration Menu screen will then go away and a new calibration target circle will appear in a corner of the screen.
- 8 Touch and hold the dot in the center of the small calibration box. The screen will report **TOUCH**, then **HOLD**, and then **RELEASE**. When done the application will register the location and move the circle to another corner. Repeat for all four corners. A blank screen will then appear.



- 9 Touch the screen to verify the calibration. A calibration circle will appear and follow your finger touch across the screen. If satisfied, touch the **Accept** button at the bottom of the screen to save the calibration.

The Calibration Menu screen then reappears. Touch **OK** at the bottom of the screen to exit the application.

## GV Korona Control Panel Adjustments

### GV Korona Lever Arm Calibration

- 1 On any EMEM area, press **Menu, Page**. This shows a list of menu items that are selected with the buttons below the display (on the left).

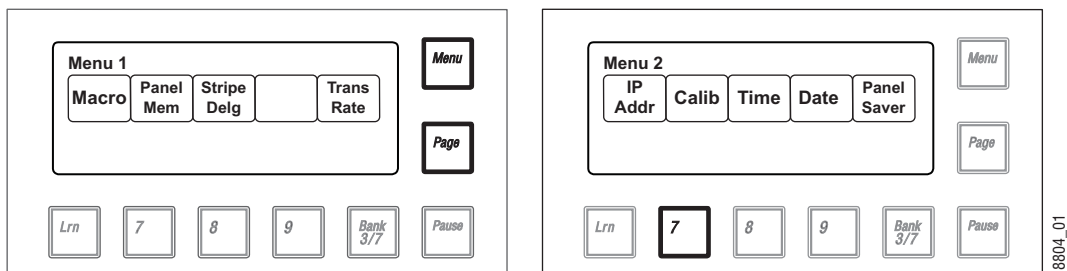

Calibration Menu, EMEM Area

- 2 Select **Calib** (press 7) to enter calibration mode (on the right).

---

**Note:** Pressing the **Menu** button at this time exits calibration mode without making any changes.

---

- 3 Choose the ME Lever Arm to calibrate. Lever 1 is the topmost Lever Arm on that panel. For example, to choose the second Lever Arm select **Lever 2** (press **8**).

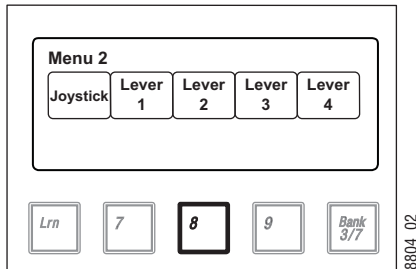

*Lever Arm Selection, EMEM Area*

- 4 In the Status Display, follow the instructions displayed (as shown):
  - a Move the Lever Arm down all the way and select **Next**.
  - b Move the Lever Arm up all the way and select **Next**. This saves the calibration values and exits calibration mode.

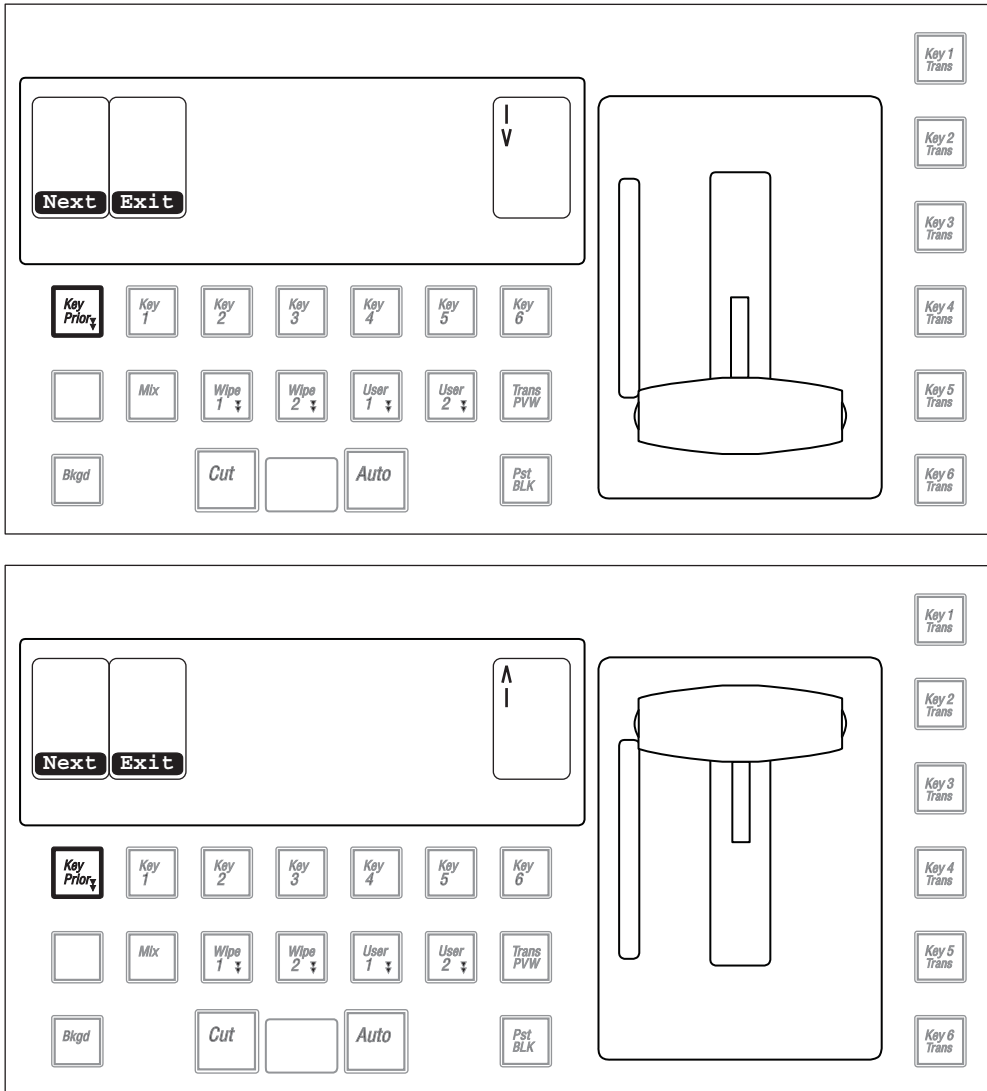

8804\_03

*Lever Arm Calibration Procedure, Transition Area*

**Note:** Selecting **Exit** cancels the Lever Arm calibration mode and returns that Transition Area to transition operations, but may leave the Lever Arm in an un-calibrated state. Complete the entire calibration procedure to ensure normal operation.

## GV Korona Joystick Calibration

- 1 On any EMEM area, press **Menu, Page**. This shows a list of menu items that are selected with the buttons below the display.
- 2 Select **Calib** (press **7**) to enter calibration mode.
- 3 Choose the **Joystick** to calibrate (press **Lrn**).



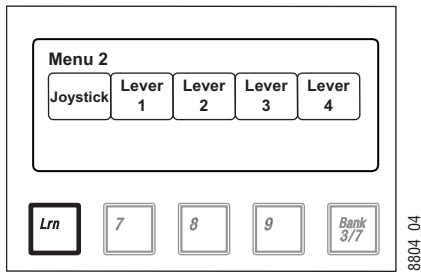

Karrera Joystick Selection, EMEM Area

- 4 Follow the joystick calibration instructions shown on the EMEM display.
  - a Move the Joystick to the top left corner, rotate it counter-clockwise, hold, and press **Lrn**.
  - b Move the Joystick to the bottom right corner, rotate it clockwise, hold, and press **Lrn**.
  - c Allow the Joystick to return to its center, unrotated position, hold, and press **Lrn**.

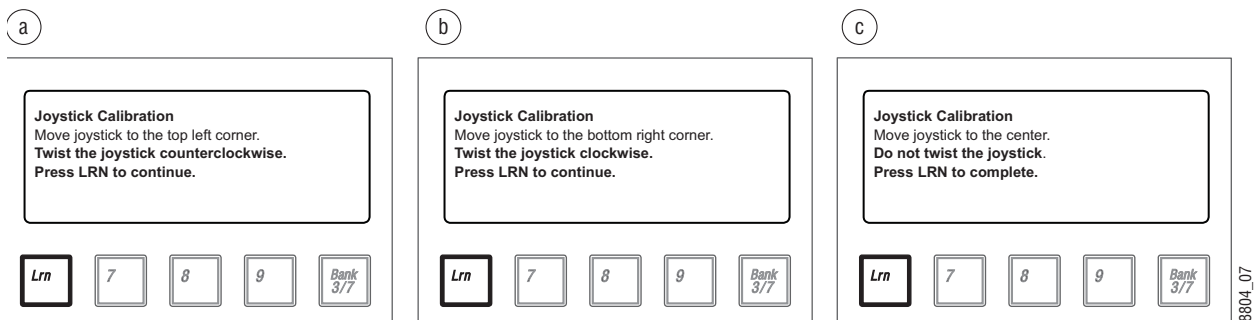

Joystick Calibration Instructions 2, 3, EMEM Area

**Note:** Pressing the **Menu** button cancels the Joystick calibration mode, but may leave the Joystick in an un-calibrated state. Complete the entire calibration procedure to ensure normal operation.

## GV Korona Panel Saver Time Adjustment

- 1 On any EMEM area, press **Menu, Page**. This shows a list of menu items that are selected with the buttons below the display (on the left).

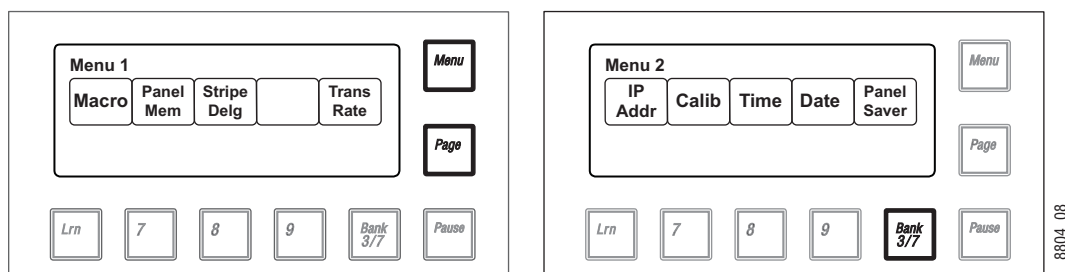

Karrera Calibration Menu, EMEM Area

- 2 Select **Panel Saver** (press **Bk 3/7**).
- 3 Once in panel saver mode, select the time period (in minutes) of inactivity required to initiate the panel saver mode using the buttons below the display. The illuminated button indicates the current setting.

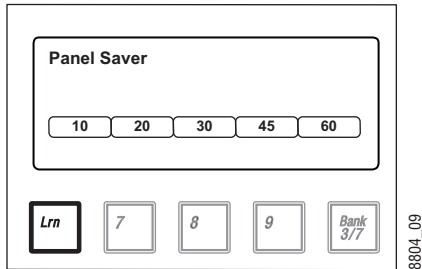

## Software Installation

K-Frame systems are shipped with the current software version installed. Updates to GV Switcher system software are available for download from the Grass Valley website. Software installation tools are provided with each update package.

## Software Option Authorization

Some K-Frame system options have software components that can be enabled via an authorization process, using authorization codes. Authorization codes are also used for tracking maintenance contracts.

New K-Frame systems ship with the appropriate authorization codes installed, enabling all purchased options. When new optional features become available, Grass Valley sends new authorization codes to the customers.

### Authorization Codes

The authorization process involves receiving an authorization code from Grass Valley and entering it in a menu on the system. The authorization code is associated with a particular K-Frame Video Processor, identified by a System ID#, and is not transferable to different hardware. If you have multiple systems at your facility, you will need to enter an authorization code onto each system.

Standard authorization codes (Permanent) apply to purchased options and maintenance contracts. Other authorization codes (Temporary) may also be available that can enable selected options for a limited time. Temporary authorizations can be used for trial demonstrations and other special purposes. Temporary authorizations add to any permanently enabled options, but these additional options are disabled after the allotted time elapses.

### Expiration Dates

Maintenance contract and temporary authorizations have expiration dates. Messages will be posted on the GV Switcher menu when an expiration date approaches. Expirations occur at midnight, but do not immediately go into effect. Instead, any expired options continue to operate until the system is power cycled or reset, at which time the options are disabled. This is intended to prevent loss of functionality

during on-air operations. Expiration of the maintenance portion of an authorization will not disable any options.

## Authorization Procedure

### Acquire Authorization Code

Grass Valley will be sending authorization codes to all K-Frame system customers. If you have received your codes and the system IDs are correct, proceed to [Enter Permanent Authorization Code](#). If you do not have valid authorization codes you will need to acquire them from the Grass Valley.

- 1 Go to the Install Options menu by touching **Eng Setup, Install Options**.

The screenshot shows the 'Install Options' menu in the Grass Valley system configuration interface. The interface includes a sidebar with navigation buttons, a main display area with a table of options, and a bottom navigation bar.

**System ID:** Kayenne  
12345678

Option	Enabled	Total Licensed	Perm	Temp 1	Temp 2	Temp 3	Temp 4	New
Full ME	#	#	#					0
Controller ME	1	1	1					0
ClipStore Channels	4	4	4					0
Image Store Cache Size (GB)	32	32	32					0
Chronos Keyframes	54	54	54					0
DSM Channels	16	16	16					0
RGB Color Correction	Yes	Yes	Yes					—
iDPM	2	2	2					0
FlexiKey™	Yes	Yes	Yes					—
DoubleTake™	Yes	Yes	Yes					—
Ethernet Tally	Yes	Yes	Yes					—
Soft Panel	Yes	Yes	Yes					—
iDMP	Yes	Yes	Yes					—
SelfDef MatchDef Scalers	24	32	32					0
HD 1080p	Yes	Yes	Yes					—
2D DPMs	Yes	Yes	Yes					—
Image Store Movies	Yes	Yes	Yes					—
ME View	Yes	Yes	Yes					—
Multiviewer	4	4	4					0
Start Date								
End Date								

The bottom navigation bar includes buttons for: Eng Login, Mod I/O, Source Definition, Outputs, Ports & Devices, Switcher Tally, Router, ClipStore Config, Video Settings, Node Settings, **Install Options**, Test Patterns, Status, Save Load, Acquire Resources, eDPM, SWR, User Setups, File Ops, E-MEM & Timeline, Macros, Source Ops, ME, Keyer, iDPM, Wipes, Copy Swap, Devices, Image Store, Router, and Eng Setup.

- 2 Write down the System ID displayed on the upper left portion of the menu.
- 3 If you have more than one system, repeat the above steps on every system that will have options enabled.
- 4 Contact Grass Valley Customer Support and request a code for each K-Frame System ID. If options have not already been purchased, you can order the options directly from the service representative.

## Enter Permanent Authorization Code

- 1 Go to the Install Options menu (**Eng Setup/Install Options**) on a menu of the system whose options you are enabling. Confirm that the System ID on the menu matches the System ID# of the authorization code.
- 2 Select the **Perm** button in the Option Group pane.
- 3 Select the **New Auth Code for Perm** data pad and enter the code on the pop-up keypad.

---

**Note:** System ID and Authorization Codes are alphanumeric and need to be entered exactly. Authorization codes do not use the letters "o" or "l" to avoid confusion with the numbers "0" and "1". The dashes in authorization codes are required for use.

---

- 4 Touch the button labeled either **Replace** or **Install** next to the new authorization code. The codes will be added and the expiration date of any maintenance contract will be indicated. If you do not believe the option statuses reported are correct, contact Grass Valley Customer Support to resolve the issue.
- 5 If options were removed, reset the Video Processor Frame.

---

**Note:** When an option is removed, it remains operational until the Video Processor Frame is reset or power cycled. When an option is added, it becomes operational immediately without requiring a Frame reset.

---

- 6 Write down the authorization codes, specifying which system they apply to, and store this information in a safe place, should you need to re-enter the codes at some time in the future.

## Temporary Authorizations

For demonstration or rental, optional features can be authorized temporarily. Once you have obtained the temporary authorization code, enter it on the K-Frame system using the procedure described above, except you first select one of the **Temp** buttons. Temporary authorization information is displayed on the right portion of the menu. Up to four temporary authorizations are allowed at a time. Temporary authorization features that are removed remains active until the Video Processor Frame is reset.

## Control Panel Web Pages

Web browser access is available for the K-Frame Control Panels. Using any web browser able to access the network, type the IP address in the browser's Address field to view the Control Panel web pages.

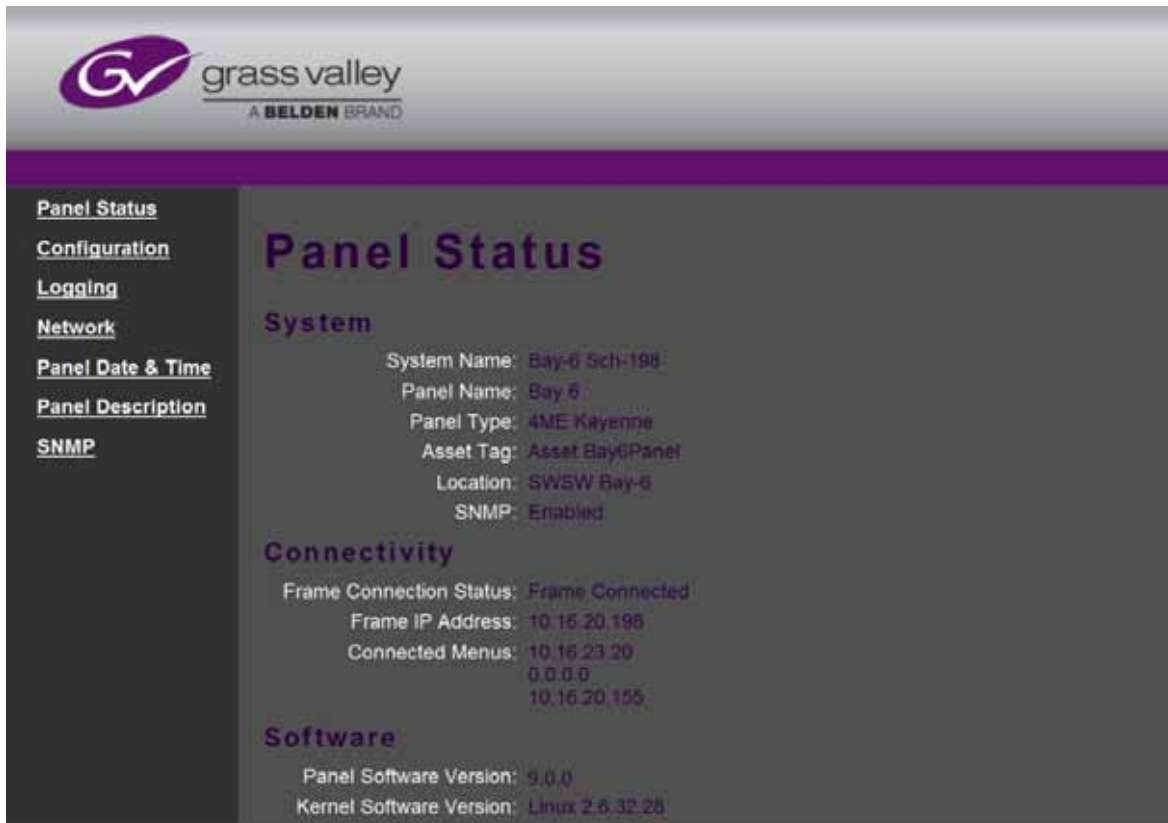

## Control Panel NV Memory

The Control Panel circuitry has NV Memory, which stores some Control Panel configuration information, including:

- Macro Attachments
- Panel Memory

Some related panel settings can be saved as configuration files (Panel Prefs, Panel Memory), or as part of a Show file. Should Control Panel software problems occur, clearing the Control Panel NV memory may help with diagnostics and recovery.

## Clear Control Panel NV Memory Procedure

Use the following procedure from the a GV switcher menu application that operates with the updated Video Processor Frame.

---

Note: A new Menu Panel or PC that has not been used with the switcher system will need to be configured as a Control Surface Node before it can operate with a switcher system.

---

- 1 From the K-Frame Installer menu, select the **System** button and then the Kayenne , Karrera, or GV Korona Control Panel to be cleared.

- 2 Select **Clear NV**.
- 3 Select the **Clear NV** button. A Clear NV Files screen will appear.
- 4 Leave the **Reboot when complete** box filled and click **OK**.
- 5 NV Memory will be cleared and the Menu or Frame will be rebooted.

### Restoring Multiple Control Panels

If your K-Frame system has multiple Control Panels connected to the same Frame (PCU Frame for Kayenne), the Clear NV process will clear settings for all the connected panels. Because separate Panel Prefs exist for each Control Panel, you will need to restore each Control Panel's configuration files individually.

## Control Panel IP Information

After a panel processor board replacement, the Video Processor Frame IP address will need to be re-entered into the Control Panel.

## Kayenne/Karrera Menu Panel IP Information

Replacing a Menu Panel processor will require resetting all Menu Panel IP addresses. This includes the actual Menu Panel IP addresses, as well as the addresses the Menu Panel uses to communicate with the Video Processor Frame and Control Panel (DPOPs).

## Video Processor Frame Maintenance

### Video Processor Frame NV Memory

K-Frame system non-volatile memory (NV Memory) contains Engineering, Suite, and User configuration data, and also has data for all the effects registers. This data is stored as files on the Video Processor Frame Solid State Drive, and is loaded on bootup. Errors in this data could cause system problems, which may be overcome, perhaps only temporarily, by clearing the NV Memory.

---

**Note:** You should have backup copies of your configuration and EMEM files compatible with your current software version so they can be restored after the NV Memory is cleared.

---

### Clear NV RAM for Control Panel and Frame

Use the following procedure from the Menu Panel or Menu on PC running the Menu Panel application that operates with the updated Video Processor Frame.

---

**Note:** A new Menu Panel or PC that has not been used with the switcher system will need to be configured as a Control Surface Node before it can operate with a switcher system.

---

- 1 From the K-Frame Installer menu, select the **System** button and then the device to be cleared.
- 2 Select **Clear NV**.
- 3 Select the **Clear NV** button. A Clear NV Files screen will appear.

- 4 Leave the **Reboot when complete** box filled and click **OK**.
- 5 NV Memory will be cleared and the Menu or Frame will be rebooted.

## Restore System Files

If you have a Show File with a set of standard K-Frame system settings, you can load it now to restore your system to that state. However, if you are experiencing problems, you may want to reload the files individually to help find what might be causing problems.

- 1 For troubleshooting, restore your backup files in the following order:
  - a Reload your backup Engineering Setup file and make sure it is correct by, for example, checking that the proper source names appear in the Source Definition menu.
  - b Reload a Suite Prefs file and a User Setups file and check that these settings are correct.
  - c Load some EMEMs and run them to check that they operate correctly.
- 2 If there are any problems with any of the restored files, they may have become corrupted and need to be deleted and rebuilt. If a problem file locks the system, you may need to clear NV Memory again to restore system operation, but you will know what file is responsible. Contact Grass Valley Customer Support if you need troubleshooting assistance.

## Restoring Multiple Suites

If your K-Frame system is configured has multiple suites, each suite will have its own Suite Prefs file. Clearing Video Processor Frame NV Memory will both suites, so to restore the system completely you will need to reload Suite Prefs for each suite.

## IP Address Information

Storing Video Processor Frame IP address information on the backplane of the Frame allows control processor board replacement without the need to enter the IP address of the Frame.

After control processor board replacement you will need to go to the Node Settings menus (**Eng Setup, Node Settings**) and re-enter Panel and Menu IP addresses (**Control Surfaces**), and Remote Aux information (**Remote Aux IP Network**)

## License Information

License information stored on the Video Processor Frame EEPROMS determine which features are available for use. Licensing is keyed to the serial number (System ID) for the K-Frame Video Processor.

## VP Frame Processor Board Replacement

When replacing the K-Frame Video Processor Frame control processor board, in either the 6U or 13U K-Frame, verify that the S2 Boot Mode Dipswitch settings are all in the **UP** or **Normal** position. The dipswitch is located below the SATA drive on the control processor board.

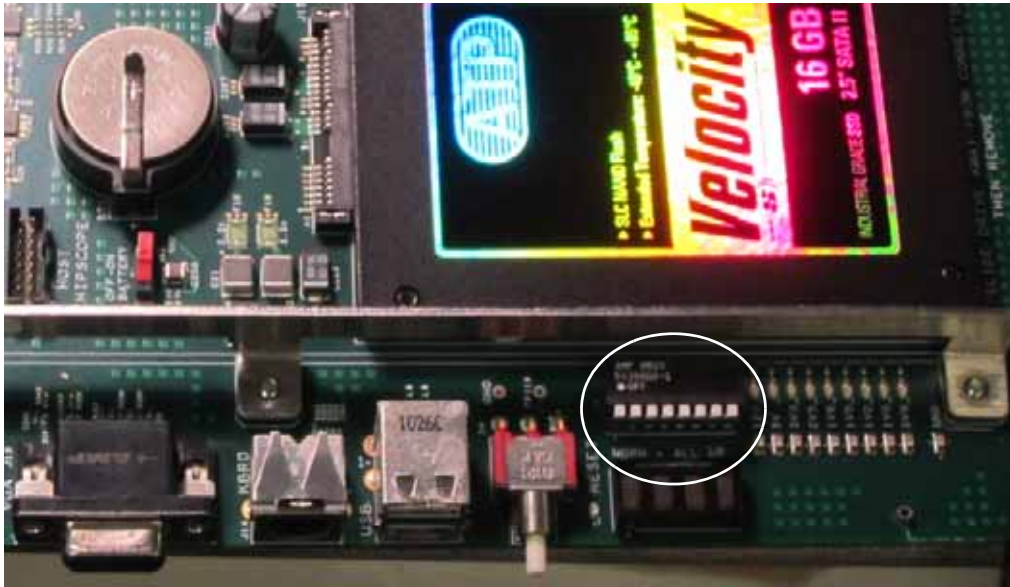

*K-Frame Control Processor Board - S2 Boot Mode Dipswitch Location*

CAUTION: If the Dipswitch settings are not in the UP or Normal position, the system may not boot.

## Lifetime of the Internal Battery

Battery life of the K-Frame Video Processor internal battery is dependent on the operating time of the switcher.

Battery information:

- Capacity:1000 mA/h
- GV Part Number:146013800
- Type:CR 2477

## Video Processor Frame Battery Replacement

- 1 Turn off all power to the Frame before opening it.
- 2 Using a grounding strap, open the door to the Video Processor Frame and remove the Controller Board.
- 3 Remove the old battery by lifting the clip holding it in place.



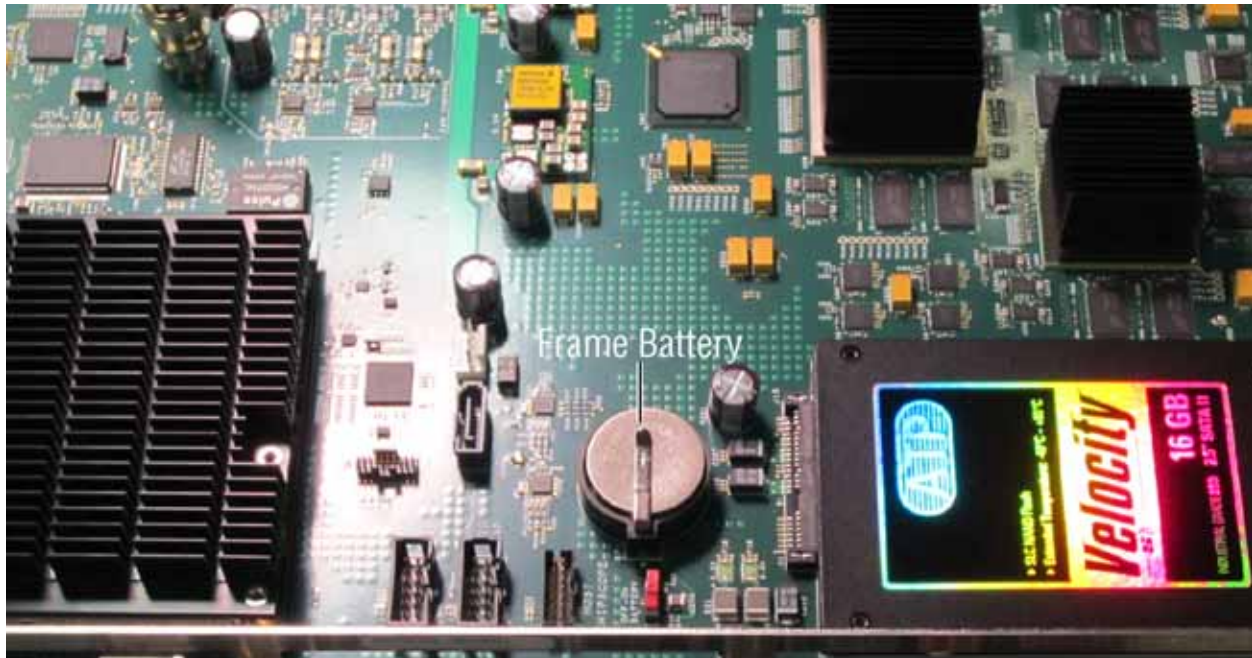

*Video Processor Frame Controller Board with Battery Indicated*

- 4 Put the new battery in place and secure the clip.
- 5 Re-insert the frame controller board and close the frame door.

## IP Information

The Video Processor Frame IP address will need to be re-entered using the K-Frame Installer program.

### Kayenne/Karrera Menu Panel IP Information

Menu Panel IP information resides on each Menu Panel processor, using standard Windows OS methods. Replacing a PCU processor board, or Menu Panel option board, will require resetting all Menu Panel IP addresses. This includes the actual Menu Panel IP addresses, as well as the addresses the Menu Panel uses to communicate with the Video Processor Frame and Control Panel (DPOPs).

## Kayenne Control Panel System Bar Maintenance

The System Bar is only present on the Control Panel Pgm Pst Stripe. On larger Control Panels the System Bar has two main parts. The right active part is called the System Bar, and the left part is called the Extended System Bar. On 35 button Kayenne systems an additional System Bar blank panel is used.

The right System Bar has a socketed electrical connector inside the tray. The left Extended System Bar uses a flat ribbon cable.

## Removing the Kayenne System Bar

Each active System Bar part is fixed to the tray with one hex screw recessed into the top surface of the part. A 2.5 mm hexagonal driver (Allen wrench) is used for removal. This tool is provided with the Control Panel. The blank panel is held in place with a single crosshead Phillips screw located underneath, but lacking active components it will probably never need to be removed.

- 1 Insert the driver and turn the hex screw counter clockwise. As the screw is turned the System Bar part will lift up because it is spring loaded.



*Unscrewing the System Bar*

- 2 The right System Bar will disengage from its socket as it is unscrewed. Once it is completely unthreaded it can be lifted out of the tray. You may need to tilt it to a flat, horizontal position to allow clearance for removal.
- 3 After unscrewing the left Extended System Bar and lifting it out of the tray, the flat cable on the left will need to be removed. Press the push clamps on the plug to connect or disconnect the plug.

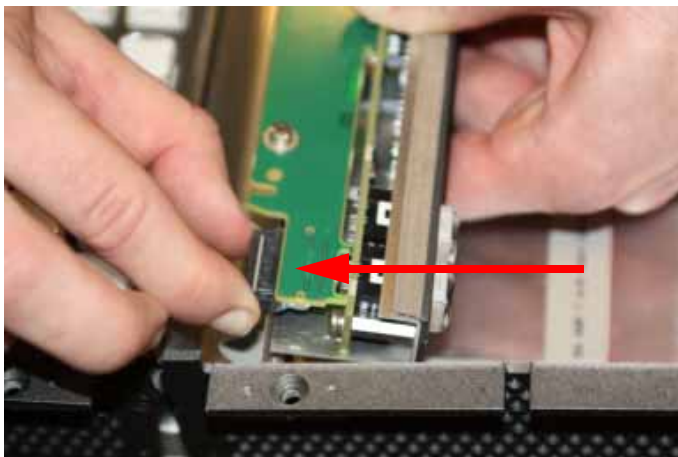

*Extended System Bar Cable Removal*

- 4 Should the blank panel need to be removed, you must first take out the module below it in the Pgm Pst tray to access a crosshead Phillips screw.

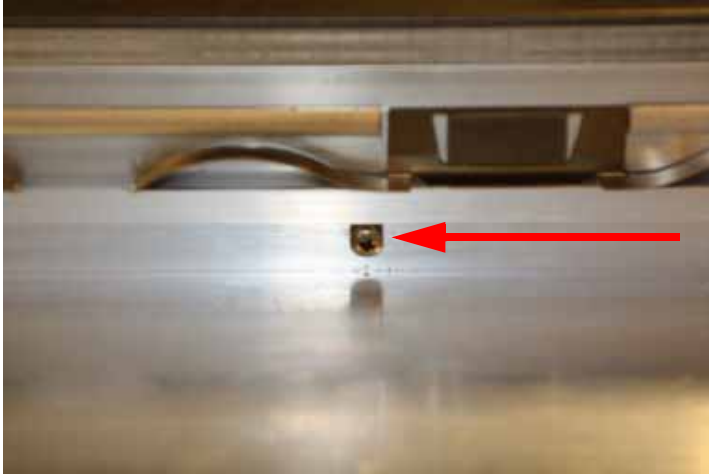

*System Bar Blank Panel Screw*

## Replacing the Kayenne System Bar

- 1 Align the System Bar horizontally and screw it into place using the provided hex tool. Do not push down on the screw. The module pulls itself into the plug while the screw is tightened.



*Aligning the System Bar for Replacement*

- 2 On larger Control Panels, connect the flat ribbon cable to the Extended System Bar, align it horizontally and screw it into place as above.
- 3 If the blank panel needs to be replaced, you will need to hold the blank panel parts in place so the screw holes are aligned before threading the screw.

## Diagnostics

### Capture Software Diagnostic Data

Software diagnostic data can be captured on a K-Frame Video Processor. This information can be useful to Grass Valley engineers for troubleshooting purposes. Typically this procedure is only used when the system is experiencing problems, and is done after a Video Processor Frame reboot.

Note: During the diagnostic data capture the K-Frame system may remain functional, but system operation is not recommended at this time. Leave the Software Diagnostic menu displayed and monitor the file save process shown at the top of the menu to allow optimum information collection.

- 1 Select **Status, Capture Software Diagnostic Data** in the menu. A file browser window will open.

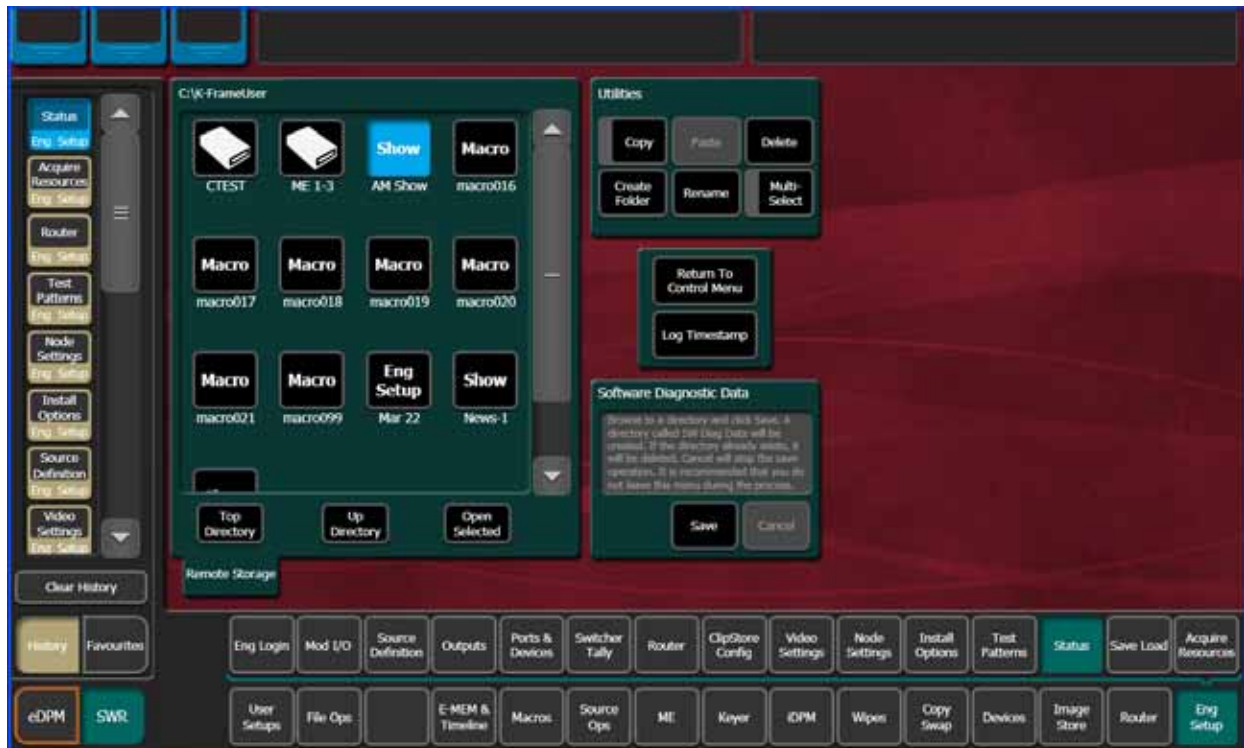

- 2 After selecting the destination for the files in the left pane, press the **Save** button to initiate the file copy process. A SW Diag Data directory will be created (or overwritten if one already exists) containing GV Switcher system data. The time required to transfer the files varies depending on the amount of data being saved, and may take several minutes.
- 3 After the files have been copied, the entire contents of the directory should be compressed into a .zip archive. Grass Valley Customer Support can provide instructions on how to send this information to the GV engineering team for analysis.

## Kayenne Control Panel Module Diagnostics

On Control Panels, boot information/diagnostic is shown on the left most character display of every panel board. This information is immediately visible after a power cycle and present until the application software writes the first data to the character displays

Table 1. Control Panel Board Boot Display Codes

Digit				
3	2	1	0	Digit Zero shows the link and FPGA boot status
			*	1. Module interface link is working (normal/default). 2. FPGA was loaded over application area (normal/default).
			+	1. Module interface link is working (normal/default). 2. FPGA was loaded over factory area: application area damaged, reprogramming necessary.
				1. Module interface link is not working: link should come up after 1-3 seconds, if not there may be a hardware problem. 2. FPGA was loaded over application area (normal/default).
			!	1. Module interface link is not working: link should come up after 1-3 seconds, if not there may be a hardware problem. 2. FPGA was loaded over factory area: application area damaged, reprogramming necessary!.
Digit 1 shows the lower number of the FPGA firmware version.				
Digit 2 shows the middle number of the FGPA firmware version.				
Digit 3 shows the upper number of the FPGA firmware version. (X1 always shows "!" to see the difference to the released versions).				

Example codes:

Table 2. Control Panel Module Boot Display Codes Examples

Digit				
0	3	7	*	1. Module interface link is working (normal/default). 2. FPGA was loaded over application area (normal/default). 3. FPGA firmware version is 037 (DS1281.037).
0	3	7	+	1. Module interface link is working (normal/default). 2. FPGA was loaded over factory area: application area damaged, reprogramming necessary. 3. FPGA firmware version is 037 (DS1281.037).
0	3	7		1. Module interface link is not working: link should come up after 1-3 seconds, if not there may be a hardware problem. 2. FPGA was loaded over application area (normal/default). 3. FPGA firmware version is 037 (DS1281.037).
0	3	7	!	1. Module interface link is not working: link should come up after 1-3 seconds, if not there may be a hardware problem. 2. FPGA was loaded over factory area --> application area damaged, reprogramming necessary. 3. FPGA firmware version is 038 (DS1281.038).
!	3	5	*	1. Module interface link is working (normal/default). 2. FPGA was loaded over factory area because X1 doesn't have a application area (normal/default). 3. FPGA firmware version is X1 and 35 (DS5831.035).
!	3	5		1. Module interface link is not working: link should come up after 1-3 seconds, if not there may be a hardware problem. 2. FPGA was loaded over factory area because X1 doesn't have a application area (normal/default). 3. FPGA firmware version is X1 and 35 (DS5831.038).

### About Updating the HAD FPGA

HAD (Host Address Decoder) FPGA (Field Programmable Gate Array) updates are to be performed by qualified personnel only, i.e. an EIC (Engineer In Charge).

Each CPU or Image Store board installed in a Grass Valley K-Frame Video Processing Frame has a PCI Express endpoint for communication with the host processor. These PCI endpoints are governed by the HAD FPGA. Software updates can include firmware updates for these endpoint HADs.



## When to Update the HAD FPGA

A HAD update is required if HAD out-of-date notifications appear in the menu approximately five minutes after the Frame is booted. A software upgrade or board replacement if the board has an older HAD version, can cause the out-of-date firmware notification to be displayed. It is recommended that spare CPU/Image Store boards are upgraded before use. Out-of-date firmware notification can also be seen from a connected serial console or Telnet connection.

Switcher menu notification:

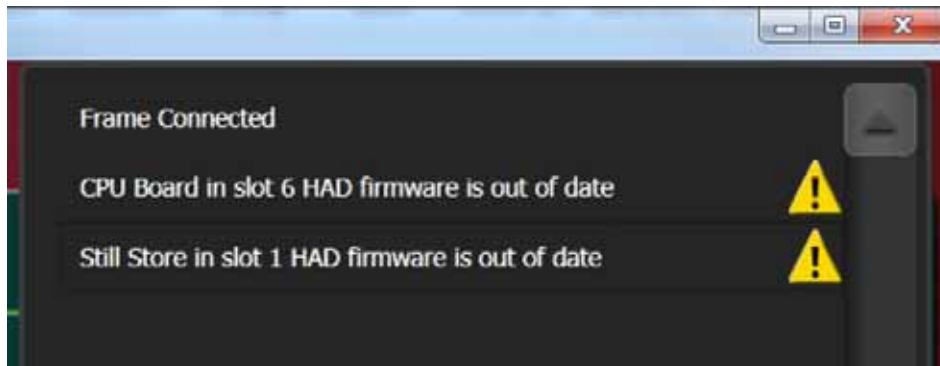

*HAD FPGA Menu Notification Message Example*

Serial console message example:

```
CPU Board in slot 6 HAD firmware is out of date
HAD revision = 1, latest file revision = 2
HAD E5E00000: CPU Board 6, Num.Ver.Rev 2000.b.1, TimeStamp 05/17/2013 14:01, DMA:Yes
Still Store in slot 1 HAD firmware is out of date
HAD revision = 0, latest file revision = 1
HAD E1800000: Still Store 1, Num.Ver.Rev 5000.b.0, TimeStamp 05/21/2013 16:23, DMA:N/A
```

## Update the HAD FPGA

The HAD FPGA update can be performed using either a serial console attached to the front edge of the Controller board using the DB9 connector or a Telnet session.

**CAUTION:** It is recommended that HAD (Host Address Decoder) FPGA (Field Programmable Gate Array) updates are performed by qualified personnel only, i.e. an EIC (Engineer In Charge).

### Update the HAD FPGA Using a Serial Console

- 1 Open the Frame door and attach the serial console cable to the front edge of the Controller board (see the version 8.0 Installation & Service Manual for your K-Frame model for more information).
- 2 Verify and/or set the serial parameters to:
  - 115200 baud
  - 8 data
  - no parity
  - 1stop

- 3 To check the HAD status, enter checkHADs at the prompt:

->checkHADs

Result:

HADs up-to-date: value = 1 = 0x1

HADs out-of-date: value = 0 = 0x0

- 4 Enter the console menu by typing consoleMenu at the prompt:

->consoleMenu

Result:

```
-> consoleMenu
[1] Status           [2] Controller       [3] ME
[4] Input            [5] Output           [6] ModIO
[7] Image Store      [8] Spare            [9] Debug
[10] Software Options [11] Fan Controller  [P] Power Supply
[H] Boot Sw Help    [Z] Test Diagnostics [D] DisableAllUpdates
[M] DisableAllMonitoring [x] Exit to shell
>
```

- 5 Enter the number nine [9] for the Debug menu, at the prompt: ->9

Result:

```
> 9
[1] GPI              [2] Tally            [3] MessageControl
[4] TimeThreads      [5] Router Control  [6] RDP/CPL Tests
[7] Show image info  [8] Show DMA info   [9] Feature Tests
[10] Transition       [11] Switch Image DMA [12] Temp Show All
[13] Temp Adjust Parm [14] Dump HAD Info  [15] Flash HADs
[16] NP Aux Control  [17] Field Timing   [18] CPL Msg Timing
[19] Display Re-entries [20] DebugNetwork  [21] DebugImageStore
[22] Debug Event Control [x] Exit
Debug>
```

- 6 Enter the number fifteen [15] for the Flash HADs menu, at the prompt:

->15

Result:

```
Debug> 15
Select FLASH Type
[G] Golden Configuration Image
[M] Multi Boot Configuration Image
[x] Exit (At any time, 'x' will exit)
>
```

- 7 Enter the letter m [M] for the Multi Boot Configuration menu, at the prompt: ->M

Result:

```
Confirm flashing all off HAD's?  
Summary:  
Flash Type:      MultiBoot  
Is this correct? (Y or N)>
```

- 8 Enter the letter Y to begin the reprogramming of the HADs, at the prompt: ->Y

Result: HADs are being erased and programmed which can be seen on the serial console monitor. If successful, a confirmation similar to the following will be displayed on the serial console monitor.

```
HAD Flashing Success! 8 passed, 0 failed
```

**CAUTION:** Do not power down or reset the Frame during the update process, HAD programming takes several minutes to complete.

Do not power down or reset the Frame during the update process, HAD programming takes several minutes to complete.

- 9 Once the programming is completely finished, power cycle the Frame to complete the HAD update process.

- 10 To verify the update, enter checkHADs at the prompt: ->checkHADs

Result:

HADs up-to-date: value = 1 = 0x1

HADs out-of-date: value = 0 = 0x0 (followed by a list of out-of-date HADs)

```
-> checkHADs  
value = 1 = 0x1  
->
```

## Update the HAD FPGA Using a Telnet Session

- 1 Open a Telnet Session to the Frame by clicking on the Windows Start menu and entering **telnet**, space, <**Frame IP Address**> (example: telnet 10.10.10.100) in *Search programs and files*.

- 2 To check the HAD status, enter checkHADs at the prompt:

->checkHADs

Result:

HADs up-to-date: value = 1 = 0x1

HADs out-of-date: value = 0 = 0x0

- 3 Enter the console menu by typing consoleMenu at the prompt:

->consoleMenu.

Result:



```
-> consoleMenu
[1] Status           [2] Controller       [3] ME
[4] Input            [5] Output           [6] ModIO
[7] Image Store      [8] Spare            [9] Debug
[10] Software Options [11] Fan Controller  [P] Power Supply
[H] Boot Sw Help     [Z] Test Diagnostics [D] DisableAllUpdates
[M] DisableAllMonitoring [x] Exit to shell
> _
```

4 Enter the number nine [9] for the Debug menu, at the prompt: ->9

Result:

```
> 9
[1] GPI              [2] Tally            [3] MessageControl
[4] TimeThreads      [5] Router Control   [6] ADP/CPL Tests
[7] Show image info  [8] Show DMA info    [9] Feature Tests
[10] Transition       [11] Switch Image DMA [12] Temp Show All
[13] Temp Adjust Parm [14] Dump HAD Info   [15] Flash HADs
[16] NP Aux Control  [17] Field Timing    [18] CPL Meg Timing
[19] Display Re-entries [20] DebugNetwork    [21] DebugImageStore
[22] Debug Event Control [x] Exit
Debug>
```

5 Enter the number fifteen [15] for the Flash HADs menu, at the prompt:

->15

Result:

```
Select FLASH Type
[G] Golden Configuration Image
[M] Multi Boot Configuration Image
[x] Exit (At any time, 'x' will exit)
> _
```

6 Enter the letter m [M] for the Multi Boot Configuration menu, at the prompt: ->M

Result:

Figure 1. Telnet Multi Boot Configuration Menu

```
> M
Confirm flashing all off HAD's?
Summary:
Flash Type: MultiBoot
Is this correct? (Y or N)> _
```

7 Enter the letter Y to begin the reprogramming of the HADs, at the prompt: ->Y

Result: HADs are being erased and programmed which *cannot* be seen in the Telnet session, however results can be viewed in the K-Frame, Frame Message Logs.

---

Note: After approximately seven minutes, the HAD programming results can be seen in the K-Frame log files.

---

8 Open an Internet Explorer window and enter the IP Address of the Frame to display the K-Frame Web pages.

9 Select **Frame Message Log**, then **Current**.

Maintenance  
Update the HAD FPGA Using a Telnet Session

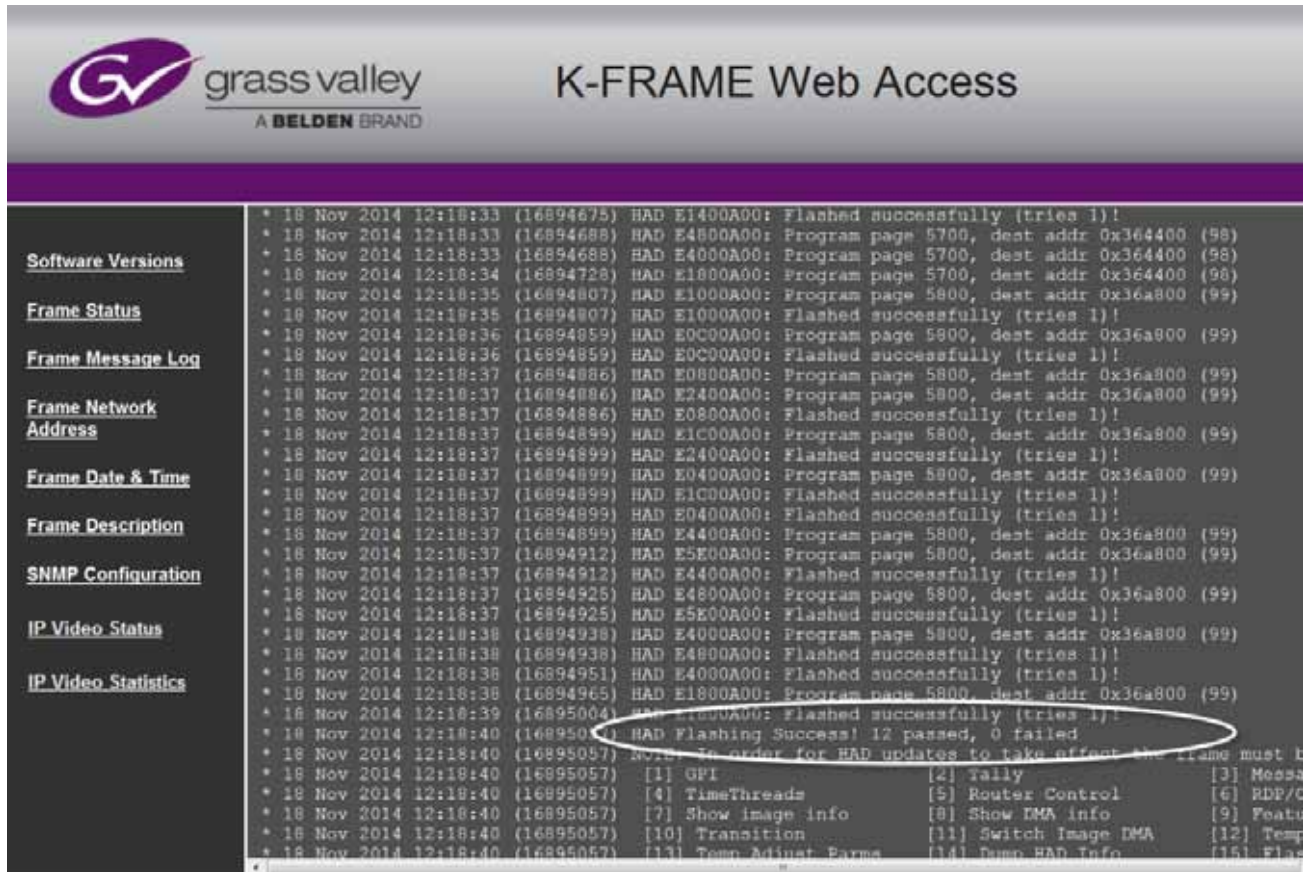

Successfully Installed HAD Example

**CAUTION:** Do not power down or reset the Frame during the update process, HAD programming takes several minutes to complete.

- 10 Once the programming is completely finished, power cycle the Frame to complete the HAD update process.
- 11 To verify the update, enter checkHADs at the prompt: ->checkHADs

Result:

HADs up-to-date: value = 1 = 0x1

HADs out-of-date: value = 0 = 0x0 (followed by a list of out-of-date HADs)

```
BRKACRU
FrameData(A0).inv
FrameData(A0).new
startup.uxsh
value = 0 = 0x0
-> checkHADs
value = 1 = 0x1
```

Updated HAD Example Menu

## Creating Compact Flash Cards

The Control Panels each use their own specially formatted and partitioned Compact Flash (CF) card. The system cannot use blank CF cards directly formatted by a PC or other device.

The K-Frame Switcher Installer program is used to format, partition, and load boot files onto system CF cards. Once prepared in this manner, the appropriate GV Switcher software (Control Panel) will need to be installed onto each card. System configuration information will also need to be reloaded and/or re-entered after CF card replacement to restore normal system operation.

### Materials Required

To format a K-Frame Control Panel CF card you will need:

- A CF card reader/writer (USB 2.0 recommended),
- PC, or Menu Panel equipped with a mouse and keyboard,
- K-Frame Switcher Installer application program deployed onto the PC or Menu Panel, and
- GV Switcher release software.

After creating new CF cards, you will need the following to restore your system to full operation:

- Backup system configuration files (a Show file, or a set of Eng Setups and User Setups files), and
- Node Settings information (IP addresses and names of all system components). This may be written notes, screen shots, or a spread sheet. This information is not saved to configuration files.

### CF Card Formatting Procedure

- 1 Connect the CF card reader/writer to the USB port of the PC or Menu Panel and insert the CF card into the reader/writer.
- 2 Launch the K-Frame Switcher Installer program.
- 3 Select **System**, **Create CF** and choose the CF card Control Panel type.
- 4 A DOS window will start, and then a separate window opens asking for the CF card location (D, E, F etc.) with the memory size of the device. Choose the correct device (CF card) to format. Even if only one CF card is present, you may still need to choose it on the list.

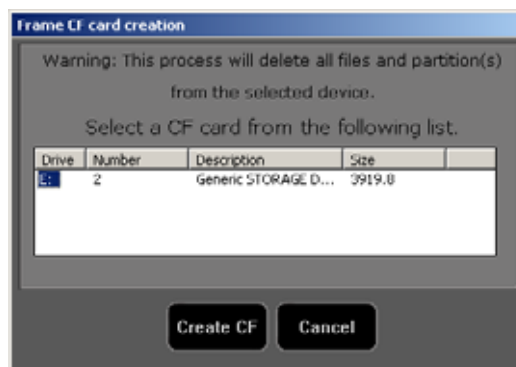

- 5 Click **Create CF**. The following screen will appear.

Maintenance  
CF Card Formatting Procedure

---

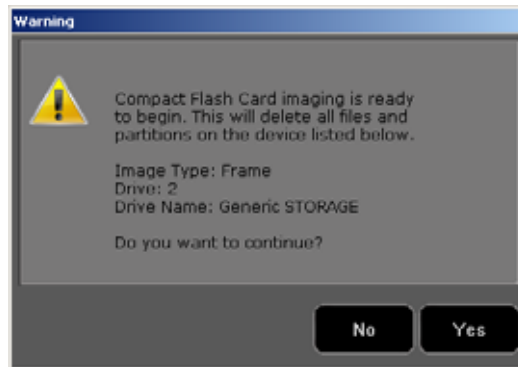

---

**CAUTION:** Any existing files or partitions on the CF card will be deleted.

---

- 6 Click **Yes**. A new Ghost application screen appears that reports the progress of the formatting. The process can take 8 to 20 minutes to fully erase, format, test and partition the CF card.

---

**Note:** For Control Panel CF cards, though the progress bar reaches 100% a couple more minutes are still required to complete the process. During this time **Configuring operating system disk layout...** is reported at the bottom of the screen.

---

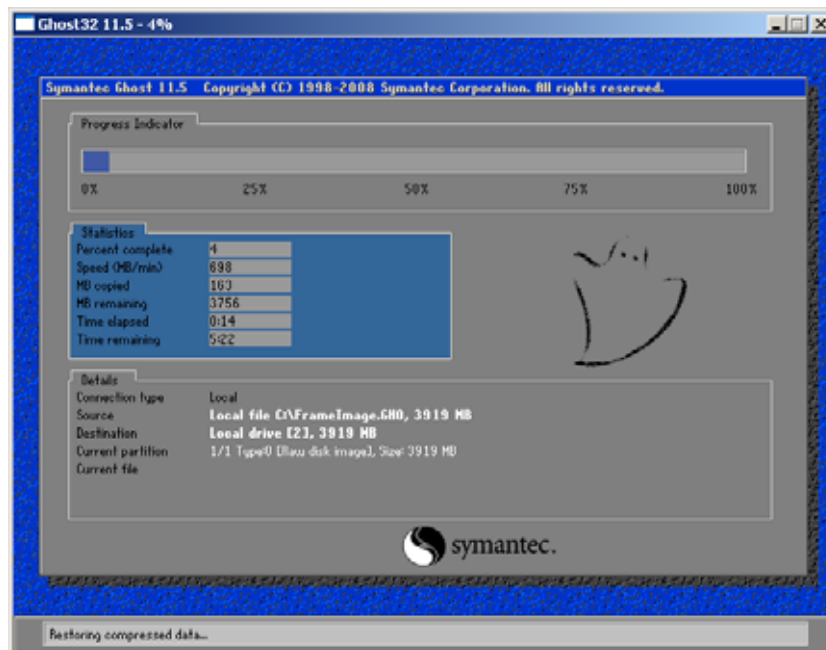

---

**Note:** Additional formatting time may be required (perhaps more than an hour) if an older USB 1.1 port or slow reader/writer device is used.

---

- 7 When finished, the Ghost window will close by itself.
  - The VP Frame Solid State Drive contains a set of files making a SWUP bootable image. These files can be seen by the Windows OS.
  - The Control Panel CF card now has a Linux O/S that can boot the Control Panel. These files are not visible to the Windows OS.

CAUTION: Do Not format CF cards using Windows.

- 8 Proceed with the appropriate update process.

## Updating System Software on a New Control Panel CF Card

- 1 Remove the CF card from the reader, power down the Control Panel, install the CF card in the Control Panel's processor, and power up the panel.
- 2 Follow the normal software update process, except the Control Panel will be identified as **Unknown / Panel** in the K-Frame Switcher Installer application program hierarchy.

## Restore Control Panel Configuration Files

After installing the K-Frame release software, you can now reload a Show file containing the Eng Setups and User Setups for your system, or reload these configuration files individually.

You will also need to enter the Node Settings information. Go to **Eng Setup, Nodes Settings**, and enter the IP address and device name information in the **Control Surfaces** and **Frame Suite Nodes & ID** tabs.

## SNMP Monitoring

Simple Network Management Protocol (SNMP) is an industry standard mechanism for monitoring devices over a network, primarily intended to support service and maintenance activity. With SNMP, devices can be interrogated about the current status of specific device components (reported as values), and devices can report without prompting (traps) certain conditions that may require immediate attention.

An SNMP system consists of one or more Managed Devices, each of which has an Agent (software running as a daemon on that device), and a Network Management System (NMS). The NMS is a software application running on a computer that communicates with the Agents over the network. The information exchanged is determined by a Management Information Base (MIB) database file. The MIB defines the structure and content of the variables that are available as data for monitoring and reporting. A Community Name is also used as a rudimentary security measure, acting as a password to enable communications with the Agent.

For example, a Managed Device may have a cooling fan and thermocouple. The MIB may define a variable for the thermocouple readout, and a request for this data can be sent from the NMS to the Agent, which will reply (if the community name matches) with the current temperature value. The MIB may also define a Trap that reports a fan failure. Should the device's fan stop working, the Agent sends an unprompted message to the NMS. The NMS can be configured to respond to that Trap message, and may have the capability to alert maintenance staff of the problem, via an automatic email message or by triggering a warning alarm.

SNMP is an optional feature for Grass Valley switchers, and requires the purchase and entry of a license key.

SNMP is an industry standard, however, any third party NMS can be used. For third party NMS installation & configuration, please contact your SNMP NMS software vendor.

Grass Valley switchers comply with the following SNMP standards:

*Table 3. SNMP Standards Supported*

RFC 1155	Structure and Identification of Management for TCP/IP-based Internets
RFC 1157	SNMP v1
RFC 1901-1907	SNMP v2c
RFC 1213	MIB II
RFC 1215	Convention for defining traps for use with the SNMP

The Grass Valley switcher MIBs are available from Grass Valley Customer Support. Load the MIBs for the Video Processor Frame and Control Panel.

*Table 4. Grass Valley Proprietary MIBs*

<b>MIB</b>	<b>Description</b>	<b>Video Processor Frame</b>	<b>Control Panel</b>
gvg-reg	last updated "200402190000Z"	X	X
gvg-element	last updated "200503230000Z"	X	X
gvg-gcp	last updated "200503240000Z"		X
gvg-vsm	last updated "201304260000Z"	X	

## Grass Valley Switcher Device Monitoring by SNMP

Grass Valley switchers support monitoring of the devices and device components shown in the following tables. SNMP provides reporting for each board of the same type, for example ME, Modular I/O input, Modular I/O output, etc.

---

**Note:** Only the capabilities described in this document are supported. For detailed information about each supported item, please refer to the MIBs.

---

## Video Processor Frame

Table 5. Supported K-Frame Video Processor SNMP Monitoring

System Information	High level information regarding the Video Processor Frame including operating system, name, location, serial number, software revision and high level frame state.
Module	Each plug in board slot in the Frame is a module (Controller, ME or eDPM). Information is provided regarding the board plugged into the slot and the current state of the slot.
Power Supply (Up to 3)	Reports power failure if a power supply fails or is not present.
Thermal	High level temperature and fan status for the entire system. If a failure is reported here then look at Fans or Temperature Sensor categories for details.
Fans	Detailed speed and status for each fan in the frame. Five fans are on the compact frame and one fan in the standard frame. Typically inspected if Thermal category is reporting a cooling problem.
Temperature Sensors	Detailed information from each monitored temperature sensor on the Frame. Typically inspected if Thermal category is reporting a cooling problem.
Video Sync	Status of external video reference signal and what type of signal is present.
Network Configuration Data	IP address, Gateway and Netmask settings for external facing network interfaces.

## Control Panel

Table 6. Supported Kayenne/Karrera K-Frame Control Panel SNMP Monitoring

Fan (3 or 2)	Kayenne: PCU has three fans. Karrera: 2ME Control Panel has one fan, 3 ME has two fans.
Power Supply (2)	Will report power failure if a power supply is not present or not plugged in.
Temperature (2 or 3)	Kayenne: One ambient temperature, one on CPU. Karrera: One ambient temperature, one on the Panel Processor FPGA, one on CPU.
Modules (Control Panel boards)	Status change traps are sent when a module is connected or disconnected.

## Menu Panel Processor

The Menu Panel Processor (the PC running the Menu application) can be monitored separately, using the standard built-in Windows SNMP capabilities and a third-party NMS. No unique Grass Valley MIB entries or traps are available.

## SNMP Installation

Grass Valley K-Frame switchers system devices have SNMP Agent software already installed. No user installation is required.

Separate NMS software (third party package) will need to be installed onto a PC that resides on the switcher network. Refer to the documentation provided with the NMS for installation instructions.

## SNMP Licensing

Grass Valley switcher system SNMP licensing is based on the Video Processor Frame, and is tied to that Frame's unique System ID number. All Control Panels associated with a Frame will use that same SNMP license.

The Frame's System ID is shown on the Menu application's Install Options screen This screen also reports the current licensing status of that Frame.



An SNMP license is purchased from Grass Valley Customer Support. You need to provide the Frame's System ID with your payment, and you will then be given a license key. Enter that license key in the Install Options screen to license the SNMP feature for that entire K-Frame system.

## Licensing Definitions

**SNMP Licensed** - SNMP is capable of running with all documented features available. See SNMP enable/disable for additional operational implications.

**SNMP Unlicensed** - SNMP runs minimal functionality provided by the operating system vendor (VxWorks on K-Frames, Linux on K-Frame Control Panels) and is always enabled.

**SNMP Enabled** - (licensed only) all SNMP variable requests are processed and SNMP traps are sent.

**SNMP Disabled** - (licensed only) all SNMP variable requests are ignored and SNMP traps are not sent.

## SNMP Power Up License Processing

Frames and Control Panels power up with SNMP Unlicensed capabilities. If a SNMP license is detected on the Frame then the Frame and Control Panel initialize SNMP licensed capabilities. SNMP Licensed Configuration must be done to properly configure some of the licensed capabilities.



## SNMP Licensed Configuration

SNMP Licensed capabilities require additional configuration through the web interface as noted in this document. The Video Processor Frame and Control Panel have separate web interfaces that are accessed by specifying the correct IP address in the URL (example: <http://192.168.1.170>). An example of the K-Frame Webpag.

Configuration steps consist of:

- Enable/Disable SNMP
- Configure Trap Destination IP addresses
- Configure Community Name

Configuration of the NMS software itself will also be required to make full use of the SNMP feature.

The screenshot displays the 'SNMP Configuration' page within the 'K-FRAME Web Access' interface. The page header includes the Grass Valley logo and the text 'A BELDEN BRAND'. The main title is 'K-FRAME Web Access'. The left sidebar contains navigation links: [Software Versions](#), [Frame Status](#), [Frame Message Log](#), [Frame Network Address](#), [Frame Date & Time](#), [Frame Description](#), [SNMP Configuration](#) (highlighted), [IP Video Status](#), and [IP Video Statistics](#). The main content area is titled 'SNMP Configuration' and contains the following configuration details:

SNMP Status	: Enabled
Enable/Disable	: <input checked="" type="checkbox"/>
Trap IP Address 1	: 10.16.23.17
Trap IP Address 2	: 10.16.15.1
Trap IP Address 3	: 10.16.47.20
Community Name	: public

Below the configuration fields is a 'Save New Settings' button. At the bottom of the configuration area, a note reads: 'Note: The Community Name will default to 'public' if none is entered'.

## Switcher Device SNMP Configuration Procedure

- 1 Check the **Enable/Disable** box to activate SNMP for that device.
- 2 SNMP configuration fields are inoperable (grayed out) if a valid license is not accessible.
- 3 Enter the IP address of the PC running a NMS where you want trap messages to be sent. Up to three IPs can be entered.

- 4 If you are not using the **public** community, enter the name of the community to be used.
- 5 Select **Save New Settings**.

## SNMP Trap Messages

The SNMP trap messages listed below are available for various switcher system components.

---

**Note:** Only the capabilities described in this document are supported. For detailed information about each supported item, please refer to the MIBs.

---

## Video Processor Frame Traps

Table 7. Supported K-Frame SNMP Traps

Name	Type	Description	Severity
vsmPowerSupplyStatusChange	status	If the current status is different than the last status then a trap is sent. A power supply OK message is only sent if all power supplies are OK after one or more power supplies have failed or been removed. At boot time, the first running status generates an informational message. After that, a transition to the running status generates a normal message.	comm error = alarm fault = alarm power supply removed = warning power supply OK = normal
vsmFanStatusChange	status	If the fan board is not present or if all fans have stopped working a trap is sent. This trap is resent every 12 seconds until the condition is corrected.  If any of the fans are not working properly a trap is sent. This trap is resent every 20 seconds until the condition is corrected.  When the system starts running normally or returns from an abnormal condition to running normally a trap is sent.	fan board not present = alarm all fans not working = alarm fan not working = warning  normal operation = informational (start up), normal (returning from a warning or alarm condition)
vsmTempStatusChange	status	If temperature crosses the warm threshold in any direction a trap is sent.	hot = alarm normal = normal
vsmModuleStatusChange	powerOK	If the current power status is different than the last power status a trap is sent.	power OK = normal power Fault = alarm
vsmModuleStatusChange	status	If the current status is different than the last status a trap is sent.	operational = normal failed = alarm not inserted = warning
vsmReferenceStatusChange	status	When the video reference transitions between locked and not locked in either direction a trap is sent.	not locked = warning locked = normal
gvgEIStateChange	status	When the switcher starts the boot process and the trap status is "initializing" a trap is sent.  Another trap is sent when the switcher becomes fully operational and the trap status is "running".	initializing = warning running = normal

## Control Panel Traps

Table 8. Supported Kayenne/Karrera K-Frame Control Panel Traps

Name	Type	Description	Severity <sup>a</sup>
gcpUnknown(1)	Panel Status Change  NOTE: This value can be a bit-wise ORing of the enumerated states. When a faulty state is fixed the corresponding bit in the value gets cleared.	The panel is in an unknown state, or does not possess enough intelligence to report its state.	normal
gcpOk(2)		The panel is connected to the equipment it is controlling and is operating normally.	normal
gcpCommunicationError(4)		The panel is unable to communicate with the equipment that it is controlling.	alarm
gcpMainPowerFault(8)		The Main power supply on the controller was removed, got disconnected from the ac line, or was faulty.	alarm
gcpRedundantPowerFault(16)		A redundant power supply on the controller was removed, got disconnected from the ac line, or was faulty.	warning
gcpFanFault(32)		The panel has detected a fault on one or more cooling fans. Karrera has up to two fans, Kayenne PCU has three fans.	warning
gcpThermalFault(64)		The temperature in the panel is too high for reliable operation.	warning
gvgElementRunning (1)	Device Status Change	The element is running and processing load.	NA
gvgElementInitializing(6)		This is a post bootstrap state where the element has been restarted, and is initializing its hardware and software components.	NA
gvgElementHalted(8)		The element has halted and not processing load.	NA
gcpModStateUnknown(1)	Module Status Change	The module is in an unknown state.	normal
gcpModRunning(2)		The module is running OK.	normal
gcpModRemoved(4)		The previously installed hot-swappable module has been removed.	alarm
gcpModCommError(9)		The system is unable to communicate with the module.	alarm

a.Severity Levels: EGvgAlarm = 6, EGvgWarning = 5, EGvgNormal = 4

# A Specifications

## K-Frame Video Processor Specifications

### K-Frame Video Standards

3G Modes	
1080p 50/59.94/60, Level A and Level B	SMPTE 424M-2006
HD Modes	
1080i 29.97/30	SMPTE 274M Tables 4 and 5
1080i 25	SMPTE 274M Tables 6
1080psf 23.976/24/25/29.97	SMPTE RP211 Table 12-16
720p 50/59.94/60	SMPTE 296 Table 1-3
SD Modes	
525i 29.97	SMPTE 259M
625i 25	SMPTE 259M

### K-Frame Mechanical

Component	Depth	Width	Height	Weight <sup>a</sup>	Rack Units
Compact 6-RU K-Frame	558.8 mm (22.0 in.)	482.8 mm (19 in.)	266 mm (10.47 in.)	31 kg. (68 lbs.)	6
Standard 13-RU K-Frame	566.2 mm (22.29 in.)	482.8 mm (19 in.)	577.1 mm (22.72 in.)	55 kg (121 lbs.)	13
Power Supply Frame	492 mm (19.73 in.)	483.1 mm (19 in.)	44 mm (1.75 in.)	11 kg (24lbs.) (Two PS modules, each weigh 2.5 kg (5.4 lbs.). Up to three modules supported.	1

a. All weights approximate.

### K-Frame Environmental

Storage temperature	-20 to 70 C (-4 to 158 F)
Operating temperature	0 to 40 C (32 to 104 F)
Relative humidity	0-95% (non-condensing)
Electromagnetic environment	E2 (according to EN55103-1 and -2)

### K-Frame Network Connections

Type of connection	10/100/1000 Base T
Protocol	TCP(UDP)/IP, Auto speed detection. Auto crossover cable configuration.
Cable and connectors	CAT5 UTP, RJ45 connectors
Max. Cable Length	100m / 300ft

Note: The K-Frame Video Processor has an internal Ethernet switch with six available external ports. One connection is required for each Control Panel and one is required for each Menu PC. An external Ethernet switch is required to connect more than six devices.

### K-Frame Video Processor Power Supply

K-Frame Video Processor Power Supply	
Line voltage	100V-240V AC +/-10% autorange, power factor corrected. Automatic line-voltage sensing for 120V and 240V sources.
Line frequency	50/60Hz +/- 5%
Power consumption	6-RU (Internal Power Supplies) K-Frame, max. 750W 13-RU K-Frame, max. 1400W
Leakage current	< 2.5 mA
Interconnect DC cable length	864 mm/34 in.

### K-Frame—Number of M/Es, Inputs, and Outputs

Frame	M/Es	Inputs	Outputs	GPI Inputs	GPI/Tally Outputs	Smart I/O Modules (MatchDef/SetDef)
Compact 6-RU	1 to 6	32 to 64 plus up to 16 MatchDef	16 to 32 dual plus 4 to 16 SetDef	8 per input board	32 per input board	Each Smart I/O module provides 4 inputs and 4 outputs with up/down/cross conversion capability
Standard 13-RU	1 to 9	32 to 160 plus up to 32 MatchDef	16 to 64 dual plus up to 32 SetDef			

#### Board Count

### K-Frame—Number of M/Es, Inputs, and Outputs

Frame	M/Es	Inputs	Outputs	GPI Inputs	GPI/Tally Outputs	Smart I/O Modules (MatchDef/SetDef)
Compact 6 RU	Up to 2 M/E boards	Up to 2 input boards (32 inputs per input board)	Up to 2 output boards (16 dual outputs per output board)			Up to 4 modules
Standard 13 RU	Up to 4 M/E boards	Up to 5 input boards (32 inputs per input board)	Up to 4 output boards (16 dual outputs per output board)			Up to 8 modules

### K-Frame Serial Digital Video Inputs

Format	ITU-R656, SMPTE 259M, 270 Mbit/s. SMPTE 292M, 1.485 Gbit/s SMPTE 424M-2006, 3 Gbit/s
Return loss	>10 dB, 1.5GHz to 3GHz
Type of Connector	75 ohm BNC (SMPTE 259M)
Nominal Amplitude	800mV peak-to-peak terminated
Channel Coding	Conforms to SMPTE 259M, SMPTE 292M
Ancillary Data	Blanked or passed (user selectable)
Embedded audio	Blanked or passed (user selectable)
EDH	Blanked
Input Impedance	75 ohm
Max cable length	HD Video 100 meters (328 ft.) using Belden 1694A type cable SD Video 300 meters (984 ft.) using Belden 1694A type cable

### K-Frame Serial Digital Video Outputs

Format	ITU-R656, SMPTE 259M, 270 Mbit/s. SMPTE 292M, 1.485 Gbit/s SMPTE 424M-2006, 3 Gbit/s
Return loss	>10 dB, 1.5GHz to 3GHz
Type of Connector	75 ohm BNC (SMPTE 259M)
Nominal Amplitude	800 mv peak-to-peak across 75 ohm +/- 10%
Rise & Fall Times	400 to 1400 picoseconds 75 ohm termination between 20% and 80% amplitude
Timing Jitter	£ 1 UI R 601/656
Alignment jitter	£ 2 UI (SD), £ 1 UI (HD)
Output Impedance	75 ohm
DC Offset	< 50mV with 75 ohm termination

## Kayenne K-Frame Control Panel Specifications

### Kayenne K-Frame Control Panel Mechanical

Component	Depth	Width	Height	Weight <sup>a</sup>	Rack Units
<b>Control Panels</b>	Curved Support Structure Orientation				
4 ME-35, with attached Local Aux Stripe, 15 m Cables	746.3 mm (29.38 in.)	1533.7 mm (60.38 in.)	559.3 mm (22.02 in.)	58 kg (127 lbs.)	n/a
3 ME-35, with Local Aux Stripe, 15 m Cables	637.1 mm (25.08 in.)	1533.7 mm (60.38 in.)	292.3 mm (11.51 in.)	45 kg (99lbs.)	n/a
2 ME-25, with Local Aux Stripe, 15 m Cables	488.4 mm (19.23 in.)	1341.7 mm (52.82 in.)	242.3 mm (9.54 in.)	30 kg (66 lbs.)	n/a
1 ME-15, with 15 m Cables, without Local Aux Stripe	356.4 mm (14.03 in.)	758.3 mm (29.85 in.)	84.3 mm (3.32 in.)	15 kg (33 lbs.)	n/a
<b>Local Aux Stripe</b>	Separately Mounted, Flat Orientation				
Local Aux-35 with 15 m Cable	185.7 mm (7.31 in.)	813.7 mm (32.04 in.)	84.3 mm (3.32 in.)	6 kg (14 lbs.)	n/a
Local Aux-25 with 15 m Cable	185.7 mm (7.31 in.)	621.7 mm (24.48 in.)	84.3 mm (3.32 in.)	6 kg (14 lbs.)	n/a
<b>Menu Panel</b>					
Touch Screen with 15 m cable	91.7 mm (3.612 in.)	417.85 mm (16.45 in.)	270.10 mm (10.63 in.)	6 kg (14 lbs.)	n/a
Menu Panel Support Arm	n/a	n/a	n/a	5 kg (11 lbs)	n/a
<b>Panel Control Unit (PCU)</b>	588.52 mm (23.17 in.)	482.60 mm (19 in.)	132.59 mm (5.22 in.)	16 kg (36 lbs)	3

a. All weights approximate.

### Kayenne K-Frame PCU Interconnects

Control Panel - PCU Connections	
Cable and connectors	Custom 7 Pin D style
Number Required	1 for each Control Panel Stripe, Local Aux Stripe, and Satellite Panel
Max. Interconnect Cable Length	15 m / 50 ft. (7.5 m / 25 ft. cable length also available)
Cable Weight	15 m / 50 ft.      1.3 kg (2.9 lbs)
	7.5 m / 25 ft.      0.7 kg (1.6 lbs.)
Touch Screen Menu Panel - PCU Connection	



**Kayenne K-Frame PCU Interconnects**

Cable and connectors	Custom 17 Pin D style	
Number Required	1 for each Menu Panel (2 maximum)	
Max. Interconnect Cable Length	15m / 50ft (7.5m / 25ft cable length also available)	
Cable Weight	15 m / 50 ft.	1.6 kg (3.7 lbs)
	7.5 m / 25 ft.	0.9 kg (2.0 lbs.)

**Kayenne K-Frame Power**

**PCU (required for Control Panel and Touch Screen Menu Panel Operation)**

Line voltage	100V-240V AC +/-10% autorange, power factor corrected. Automatic line-voltage sensing for 120V and 240V sources.
Line frequency	50/60Hz +/- 5%
Power consumption	max. 500W
Leakage current	< 2.5 mA

## Karrera K-Frame Control Panel Specifications

### Karrera K-Frame Mechanical

Component	Depth	Width	Height	Weight <sup>a</sup>	Rack Units
<b>2-ME Compact Control Panel</b>	510 mm (20.08 in.)	1010 mm (39.8 in.)	178 mm (7.01 in.)	25 kg. (55 lbs.)	n/a
<b>2-ME Control Panel</b> KRR-PNL-200-25	362 mm (14.25 in.)	1248.6 mm (49.16 in.)	132 mm (5.20 in.)	19 kg. (41 lbs.)	n/a
<b>3-ME Control Panel</b> KRR-PNL-300-35	510 mm (20.08 in.)	1440.6 mm (56.72 in.)	178 mm (7.01 in.)	28 kg. (62 lbs.)	n/a

### Optional Touch Screen Menu System:

Touch Screen Panel	91.7 mm (3.612 in.)	417.85 mm (16.45 in.)	270.10 mm (10.63 in.)	6 kg. (14 lbs.)	n/a
Menu PC (OEM) KRR-MENU-PCU	254 mm (10.0 in.)	157 mm (6.2 in.)	56 mm (2.2 in.)	4 kg. (8 lbs.)	n/a
Menu Panel Support Arm	n/a	n/a	n/a	5 kg. (11 lbs.)	n/a

### Optional Local Aux Panel

Local Aux 35	78 mm 3.1 in.	800 mm 31.5 in.	162 mm 6.4 in.	4 kg. (9 lbs.)	n/a
Local Aux 25	78 mm 3.1 in.	610 mm 24.0 in.	162 mm 6.4 in.	3 kg. (7 lbs.)	n/a

a. All weights approximate.

### Karrera K-Frame Power

#### Karrera Control Panels

Line voltage	100V-240V AC +/-10% autorange, power factor corrected. Automatic line-voltage sensing for 120V and 240V sources.
Line frequency	50/60Hz +/- 5%
Power consumption	200W
Leakage current	< 2.5 mA

#### Optional Touch Screen Menu System

##### Touch Screen Menu Panel (power brick provided and required)

Line voltage	100V-240V AC, 1.06 - 0.45A
Line frequency	47-63 hz
Power consumption	90W, max.
Power brick output	48V, 1.87A

##### Fanless PC (power brick provided, optionally powered from Karrera panel)

### Karrera K-Frame Power

Line voltage	100V-240V AC, 1.7A
Line frequency	50/60Hz
Power consumption	60W
Power brick output	12V, 5.0A
<b>Optional Local Aux Panel (35 or 25, powered from Karrera Panel)</b>	
Power input	12V DC, 0.8A max
Power consumption	< 10W

## GV Korona K-Frame Panel Specifications

### GV Korona K-Frame Mechanical

Component	Depth	Width	Height	Weight
2-ME GV Korona Control Panel	557.60mm (22.74in)	764.54mm (30.10in)	256.03mm (10.08in)	38.7lbs
1-ME GV Korona Control Panel	419.86mm (16.53in)	668.53mm (26.32in.)	229.87 (9.05in)	27.1lbs

### GV Korona K-Frame Environmental

Storage temperature	-20 to 70 deg C (-4 to 158 deg F)
Operating temperature	0-95% (non-condensing)
Relative humidity	0 to 40 deg C (32 to 104 deg F)
Electromagnetic environment	E2 (according to EN55103-1, -2)

### GV Korona K-Frame Network Connection

Type of connection	10/100/1000 Base T
Protocol	TCP(UDP)/IP, Auto speed detection
Cable and connectors	CAT5 UTP, RJ45 connectors
Maximum cable length	100m / 300ft

### GV Korona K-Frame Power

Line Voltage	100V-240V AC +/-10% autorange, power factor corrected. Automatic line-voltage sensing for 120V and 240V sources.
Line frequency	50/60Hz +/- 5%
Power consumption	50W
Leakage current	< 2.5 mA



# Field Replaceable Units

This appendix provides lists of the Field Replaceable Units (FRU) and Critical Spares for the K-Frame Video Production Center. FRUs can be ordered from Grass Valley Customer Support.

---

Note: The lists given here are for general guidelines only and are subject to change at any time. They do not reflect current pricing or availability information.

---

## K-Frame Video Processor Field Replaceable Units

Name	Part Number	Replacement Notes and References
<b>K-Frame Video Processor</b>		
13-RU Frame Assembly	761045600	Includes Midplane, Chassis, Fan Assembly
6-RU Frame Assembly	761045300	Includes Midplane, Chassis, Fan Assembly, Transition Board
13-RU Front Door	751039200	K-Frame Door
6-RU Front Door	751036000	K-Frame Door
6-RU Door Assembly	751040600	
Power Supply Frame (13RU Standard only)	761049300	Includes 1-RU Power Supply Frame w/ Power Supply Distribution PCBA
Power Supply Module	720007800	120/240VAC/48VDC
Power Supply DC Power Cable	731031200	
13-RU Control Processor Board Assembly	771052700	
6-RU Control Processor Board Assembly	771052200	
Dual Mix/Effects Board Assembly	771052301	
Video Input Board Assembly	772001401	
Video Output Board Assembly	772001500	
Control I/O Board Assembly	771051800	13RU Standard
Control I/O Board Assembly	771051850	S-series and Compact S-series
Modular I/O Board Assembly	771052800	
Modular IP I/O Board Assembly	771052900	10 GigE

**K-Frame Video Processor Field Replaceable Units**

Name	Part Number	Replacement Notes and References
Modular I/O Rear Cover	390736900	
Battery	Panasonic CR2477	Regulations prohibit the shipment of batteries outside of a system, please acquire this battery locally

**Kayenne K-Frame Control Panel Field Replaceable Units**

Name	Part Number	Replacement Notes and References
<b>Kayenne Panel Control Unit (PCU)</b>		
Panel Control Unit (standard)	761037800	Includes PCU Chassis and Backplane only.
PCU Power Supply Module	86200400	
Panel/Menu Processor Board	771041802	Includes programmed 4G Kayenne (KL) CF Card.
Second Menu Processor Board	771041901	
PCU Chassis Fan Assembly	751028000	
PCU Fan Filter	378209500	
<b>Kayenne Control Panel</b>		
KAYN-PNL-TRM - Transition Module	761045100	(Replaces 8553050)
Kayenne Transition Keycap Set	85570600	
KAYN-PNL-LEM - Local E-MEM Module	85553240	
Kayenne Local E-MEM Keycap Set	85570630	
KAYN-PNL-MEM - Master E-MEM Module	85553810	
Kayenne Master E-MEM Keycap Set	721013000	
KAYN-PNL-MFM - Multi-Function Module	85553430	(Keycaps included)
KAYN-PNL-SRC-35 - Source Select Module	85552910	Modules available in 35, 25, and 15 button widths. 15 button width for 1-ME Control Panel only.
KAYN-PNL-SRC-25 - Source Select Module	85552620	
KAYN-PNL-SRC-15 - Source Select Module	85552380	
Kayenne Source Select Keycap Set (15)	721014500	

### Kayenne K-Frame Control Panel Field Replaceable Units

Name	Part Number	Replacement Notes and References
KAYN-PNL-AUX-35 - Local Aux Module	85552970	Available in 35 and 25 button widths.
KAYN-PNL-AUX-25 - Local Aux Module	85552790	
Kayenne Local Aux Keycap Set	85570500	
KAYN-PNL-SYSTEM BAR-4 DEVICE	85552040	Used with SYSTEM BAR-2 DEVICE on 25 or 35 Source Control Panels. Not used on 1-ME Control Panel. (Keycaps included)
KAYN-PNL-SYSTEM BAR-2 DEVICE	85552020	Used on 25, 35, and 1-ME Control Panels. (Keycaps included)
KAYN-PNL-DCM - Device Control Module,	85554000	Available as an option for 3 and 4-ME Control Panels, or as a Satellite Device Control Module.
4-ME Panel Support Structure	85573800	Supports either Curved or Flat configurations. Hex assembly tools included.
3-ME Panel Support Structure	85573820	
2-ME Panel Support Structure	85573840	
1-ME Panel Support Structure	85573860	
Distribution Board with Housing	85554640	
ME Stripe-PCU Cable - 7.5 m (25 ft.)	85572390	
ME Stripe-PCU Cable - 15 m (50 ft.)	85572400	
Dimple Keycaps - Small	86205210	quantity 5, 12mm AT3086, NKK
Dimple Keycaps - Large	86205220	quantity 10, 15mm, AT3087, NKK
Source Select 35 Tray Assembly (empty)	761043700	Includes distribution board, internal cables, etc. No modules.
Source Select 25 Tray Assembly (empty)	761043600	
Source Select 15 Tray Assembly (empty)	761043500	
Aux 25 Tray Assembly (empty)	761043900	
Aux 35 Tray Assembly (empty)	761043800	Includes distribution board, internal cables, etc. No modules.
System Bar 35 Tray Assembly (empty)	761044200	
System Bar 25 Tray Assembly (empty)	761044100	
System Bar 15 Tray Assembly (empty)	85572630	

**Kayenne K-Frame Control Panel Field Replaceable Units**

Name	Part Number	Replacement Notes and References
Internal Tray Cables (connect distribution board to modules)	85572430	500mm
	85572440	750mm
	85572450	1000mm
	85572460	1250mm
	85572470	1500mm
<b>Menu Panel</b>		
Menu Panel Assembly	761040601	
Menu Panel- PCU Cable - 7.5 m (25 ft.)	731027700	
Menu Panel- PCU Cable - 15 m (50 ft.)	731027600	
<b>KSP (Soft Panel)</b>		
	711056400	Custom legend keyboard for KSP
<b>Satellite Panels</b>		
1 Module width, 1 Tray (empty)	85574010	Holds one larger module (286mm, 11.25 in) or two smaller modules (143mm, 5.6 in). Includes trim, internal cables. No modules included.
1 Module width, 2 Trays (empty)	85574030	Holds two larger modules in two Trays. Larger and smaller module sizes supported. Includes trim, internal cables. No modules included.
<b>Remote Aux Panels</b>		
32-Crosspoint Remote Aux Panel (1RU)	761000300	KAL-32AUX1
32-Crosspoint Remote Aux Panel (2RU)	761000400	KAL-32AUX2



### Kayenne K-Frame Control Panel Field Replaceable Units

Name	Part Number	Replacement Notes and References
<b>Software</b>		
USB Stick	86211560	Blank
	86211560	Kayenne Menu Panel Hard Drive image backup and restore. (Labeled with s/n of PCU Frame.)
Compact Flash Card	86207620	Blank
	163843800	With Kayenne Control Panel Software installed (for PCU).
KAYN-PNL-DCM - Device Control Module,	85554000	Available as an option for 3 and 4-ME Control Panels, or as a Satellite Device Control Module.

### Karrera K-Frame Control Panel Field Replaceable Units

#### Karrera K-Frame Control Panel Field Replaceable Units

Name	Part Number	Replacement Notes and References
Source Select 10 w/o Device Control	771056600	
Source Select 15 with Delegation Sub-panel	771056300	
Source Select 15 w/o Delegation Sub-panel	771057800	
Transition & DSK	771055600	
Local EMEM & Transition	771056000	
Transition & Local EMEM	771055800	
Master E-MEM	771056100	
Multi-Function	771056200	
Processor Board	771055200	
Control Panel Distribution Board	771055300	
Local Aux 10	771056800	
Local Aux 15	771056400	
Local Aux Distribution Board	771058100	

Field Replaceable Units

Karrera K-Frame Control Panel Field Replaceable Units

**Karrera K-Frame Control Panel Field Replaceable Units**

Name	Part Number	Replacement Notes and References
Internal Panel Data Cables, RJ45 CAT6 (connect distribution board to modules)	731028500	1350mm
	731028501	1750mm
	731028502	2050mm
	731028504	1950mm
	731028505	2250mm
	731028506	1500mm
	731028507	1250mm
	731028509	750mm
	731028510	2500mm
	731028511	500mm
	731028512	250mm
	731028513	1850mm
	731028514	2150mm
	731028515	2800mm
	731028516	2350mm
	731028517	2600mm
	731028518	3050mm
	Internal Panel Power Cables (connect Distribution Board to Modules)	731028600
731028601		1200mm
731028602		1700mm
731028603		1100mm
731028604		500mm
731028605		1350mm
731028606		1850mm
XLR4 - External Power Cable	731028900	
Panel Fan Assembly	751039000	
Joystick	751041200	3-Axis Hallsens. TRY10-551
Lever Arm	751040900	
Power Supply AC/DC	720007100	12VDSC 400W 33.3 A
Power Supply Cable Assembly	731028800	Cable assembly for 720007100 power supply.
Cable Assembly Power Supply Controller	731028200	
Fuse	159504000	8A 250V 5X20mm IEC 60127-2/5
Compact Flash Card	157050000	Blank

**GV Korona K-Frame Control Panel Field Replaceable Units**

Name	Part Number	Replacement Notes and References
Controller Module	771069000	
Source Select 20 Module	771069600	
2 ME Transition Module	771069200	
Master E-MEM Module	771069400	
Encoder Module	771069500	
Source Select 15 Module	771069700	
1 ME Transition Module	771069100	
Keycap Set, GV Korona Source Select 20	721025000	
Keycap Set, Transition Module	721015500	
Keycap Set, GV Korona EMEM Module	721025200	
GV Korona Touch Screen Display Assembly	761062900	
Dual Power Supply Assembly	751055800	



## Certifications and Compliances

### FCC Emission Control

This equipment has been tested and found to comply with the limits for a Class A digital device, pursuant to Part 15 of the FCC Rules. These limits are designed to provide reasonable protection against harmful interference when the equipment is operated in a commercial environment. This equipment generates, uses, and can radiate radio frequency energy and, if not installed and used in accordance with the instruction manual, may cause harmful interference to radio communications. Operation of this equipment in a residential area is likely to cause harmful interference in which case the user will be required to correct the interference at his own expense. Changes or modifications not expressly approved by Grass Valley Group can affect emission compliance and could void the user's authority to operate this equipment.

### Canadian EMC Notice of Compliance

This digital apparatus does not exceed the Class A limits for radio noise emissions from digital apparatus set out in the Radio Interference Regulations of the Canadian Department of Communications.

Le présent appareil numérique n'émet pas de bruits radioélectriques dépassant les limites applicables aux appareils numériques de la classe A prescrites dans le Règlement sur le brouillage radioélectrique édicté par le ministère des Communications du Canada.

### EN55022 Class A Warning

For products that comply with Class A. In a domestic environment this product may cause radio interference in which case the user may be required to take adequate measures.

Canadian Certified Power Cords

Canadian approval includes the products and power cords appropriate for use in the North America power network. All other power cords supplied are approved for the country of use.

### Canadian Certified AC Adapter

Canadian approval includes the AC adapters appropriate for use in the North America power network. All other AC adapters supplied are approved for the country of use.

## FCC Emission Limits

This device complies with Part 15 of the FCC Rules. Operation is subject to the following two conditions: (1) This device may not cause harmful interference, and (2) this device must accept any interference received, including interference that may cause undesirable operation.

## Certification

This product has been evaluated for Electromagnetic Compatibility under the EN 55103-1/2 standards for Emissions and Immunity and meets the requirements for E4 environment.

This product complies with Class A. In a domestic environment this product may cause radio interference in which case the user may be required to take adequate measures.

This product has been evaluated and meets the following Safety Certification Standards

<b>Category</b>	<b>Standard</b>	<b>Designed/tested for compliance with:</b>
Safety	UL 60950	UL 60950-1 Issue 2007/03/27 Ed. 2 Information Technology Equipment-Safety Part 1 General Requirements.
	IEC 60950	IEC 60950-1 Issue: 2005/12/08 Ed. 2 Information Technology Equipment-Safety Part 1 General Requirements; Corrigendum 1: 8/2006; Amendment 1: 2009/12/17.
	CAN C22.2, No. 60950	C22.2 #60950-1 Issue 2007/03/01 Ed. 2 Information Technology Equipment-Safety-Part 1 General Requirements.
	EN60950	Safety of Information Technology Equipment, including Electrical Business Equipment.
	2006/95/EC	Low Voltage Directive

Category	Standard	Designed/tested for compliance with:
EMC	EMC Directive 2004/108/EC via EN 55103-1 and 2	Audio, Video and Entertainment Lighting Control for the European Community.
	EN55103-1 : 2009	Electromagnetic compatibility. Product family standard for audio, video, audio-visual and entertainment lighting control apparatus for professional use. Part 1 Emissions, Environment E4 EN 55022: Class A Radiated Emissions EN 61000-3-2: Powerline Harmonic Emissions EN 61000-3-3: Voltage Fluctuations "Flicker" EN 55022: Class A Conducted Emissions Radiated Magnetic Field Emissions Peak Inrush Current
	EN55103-2 : 2009	Electromagnetic compatibility--Product family standard for audio, video, audio-visual and entertainment lighting control apparatus for professional use. Part 2 Immunity, Environment E4 EN 61000-4-3: Radiated RF Immunity EN 61000-4-2: Electrostatic Discharge "ESD" EN 61000-4-4: Electrical Fast Transients "EFT" EN 61000-4-11: Voltage Dips & Fluctuations EN 61000-4-5: Power Line Surge EN 61000-4-6: Conducted RF Immunity Radiated Magnetic Field Immunity
	US FCC Class A	CISPR Pub. 22 (1985)
	Canada FCC Industry Canada	ICES-003
Australia & New Zealand:	AS/NZS 3548	

## DEKRA Certificate

Certifying that Grass Valley product meets the ISO 9001: 2008 standard.

# CERTIFICATE

Certificate Number: 510040.001

The Quality System of:

## Grass Valley, A Belden Brand and its Grass Valley Affiliates

<b>Headquarters:</b> 3499 Douglas-B Floreani St. Laurent, Quebec H4S 2C6 Canada	3030 NW Aloclek Drive Hillsboro, OR 97124 United States
Street Bergschot 69 4817 PA Breda The Netherlands	125 Crown Point Court Grass Valley, CA 95945 United States

Including its implementation, meets the requirements of the standard:

## ISO 9001:2008

Scope:

St. Laurent HQ: The design, manufacture and support of video and audio products and systems

Grass Valley and Hillsboro: Design, outsource manufacture and support.

Breda: Design, manufacture, including outsource manufacture, and support.

This Certificate is valid until: June 14, 2018

This Certificate is valid as of: June 14, 2015

Certified for the first time: June 14, 2000

Dr. Cem O. Onus  
Managing Director, Business Assurance  
DEKRA Certification, Inc.

The method of operation for quality certification is defined in the DEKRA Master Services Agreement. Integral publication of this certificate is allowed.

DEKRA Certification, Inc.  
1120 Welsh Road, Suite 210  
North Wales, PA 19454  
USA  
Ph: (215)897-4519  
Fax: (215)897-3810  
ISO 9001 Cert 00400010 Rev C

Accredited By:  
ANAB







## **Grass Valley Technical Support**

For technical assistance, contact our international support center, at 1-800-547-8949 (US and Canada) or +1 530 478 4148.

To obtain a local phone number for the support center nearest you, please consult the Contact Us section of Grass Valley's website ([www.grassvalley.com](http://www.grassvalley.com)).

An online form for e-mail contact is also available from the website.

## **Corporate Head Office**

Grass Valley  
3499 Douglas-B.-Floreani  
St-Laurent, Quebec H4S 2C6  
Canada  
Telephone: +1 514 333 1772  
Fax: +1 514 333 9828  
[www.grassvalley.com](http://www.grassvalley.com)