

Communication Protocol of PV Grid-Connected String Inverters

V1.1.39

Version number	Date	Note
V1.1.0	2016-4-11	Initial version. Unofficial version(V1.0.13) is no longer used.
V1.1.1	2016-5-13	modify the register address and some related content: 5039–Power limitation adjustment 5040–Reactive power adjustment
V1.1.2	2017-5-13	Add Inverter model : SG36KTL-M, SG10KTL-M, SG12KTL-M, SG80KTL, SG80KTL-M, SG125HV
V1.1.3	2017-6-10	Add Inverter model:SG33K3J, “Fault run” change to “Fault” Add country code: UAE, Israel, Hungary
V1.1.4	2017-6-15	AddSG125HV the number of MPPT and combiner board information
V1.1.5	2017-6-20	Add Inverter data point : State setting
V1.1.6	2017-7-10	Add Inverter fault/alarm code 007/030/031/032/033
V1.1.7	2017-8-7	Modify the name of fault code: 003/006/014/016/019/021/022/025/026/041/042//048/049/050
V1.1.8	2017-8-12	Delete Inverter fault/alarm code: 051 Add Inverter fault/alarm code: 053/054/055/056/059/060
V1.1.9	2017-9-20	Add Inverter one working state
V1.1.10	2017-9-26	Modify the code of JP
V1.1.11	2017-10-19	Add Inverter fault/alarm code 564/565/580/581
V1.1.12	2017-10-24	Add country and region code 26/27/28/29/63/64/65/66/67/59/98 Modify fault/alarm note: “LCD” changed to “LCD or APP”
V1.1.13	2017-11-2	Add Inverter data point : Total apparent power
V1.1.14	2017-11-18	Add Inverter model: SG15KTL-M, SG20KTL-M
V1.1.15	2017-11-25	Add Inverter model: SG30KTL-M Add Inverter fault/alarm code: 116
V1.1.16	2017-12-22	Add Inverter model:SG111HV Modify SG10KTL-M, SG12KTL-M limit the maximum power ratio of 110%

V1.1.17	2018-1-18	Increase the support of “Total apparent power” point inverter model information
V1.1.18	2018-03-17	Delete some product types according to overseas sales list. “U1 Limit” default value is adjusted to 950. Add Inverter fault/alarm code: 117
V1.1.19	2018-04-24	Add Inverter fault/alarm code: 34/106 Add country code: US-NE
V1.1.20	2018-05-24	Add PID work state, PID night recovery, PID day protection, PID alarm code
V1.1.21	2018-06-15	Adjust the description of fault code 44 Adjust the description of fault code 23/40 Add Inverter fault/alarm code: 45/46 Add Appendix 5
V1.2.22	2018-08-07	Add Inverter fault/alarm code: 105 Add Inverter model : SG110HV-M
V1.1.23	2018-8-17	Adjust the description of fault code 2/15
V1.1.24	2018-08-31	Add Inverter data point : DC Voltage 6 –DC Voltage 12, DC current 6 –DC current 12; Current of 19 th input–Current of 24 th input Delete the fault/alarm code 6/26/75 Adjust the description of fault code 15/74
V1.1.25	2018-09-18	Adjust address :DC Voltage 9 –DC Voltage 12, DC current 9 –DC current 12 Add country code: MYS/PHL, Add Inverter fault/alarm code: 566/567/568/569/570/571,582/583/584/585/586/587
V1.1.26	2018-11-7	Add Inverter fault/alarm code: 448-471
V1.1.27	2018-11-7	Add Inverter model: SG33CX, SG40CX, SG50CX, SG110CX, Add SG5-20K Meter information(read-only register:5083-0104, holding register:5009-5015) Modify the name of fault code: 030/031/032/033/042 Add Q(U)/Q(P) curve definition
V1.1.28	2019-4-9	Add Inverter model: SG250HX
V1.1.29	2019-5-23	Add Inverter fault/alarm code: 220/221/222/223/224/225/226/227/514 Modify the SG250HX power limitation setting range 0-1110, See Appendix 6. Add Inverter model: SG30CX/SG36CX-US/SG60CX-US/SG250HX-US
V1.1.30	2019-9-21	Add Inverter model: SG25CX-SA/SG100CX-JP, SG250HX-IN
V1.1.31	2020-3-12	Add Inverter fault code 1500-1531

V1.1.32	2020-6-17	Adjust the description and applicable Inverter of points, update Appendix6, Appendix 9, Appendix10
V1.1.33	2020-7-10	Add Inverter model: SG250HX-IN-20
V1.1.34	2020-8-15	Add Full-Day PID Suppression, Installed PV Power
V1.1.35	2021-1-28	1. Add Inverter model:SG75CX 2. Update Country ID 3. Add 100% Scheduling to Achieve Active Overload
V1.1.36	2021-2-7	1. Add Inverter model: SG3.0RT, SG4.0RT, SG5.0RT, SG6.0RT, SG7.0RT,SG8.0RT, SG10RT, SG12RT, SG15RT, SG17RT, SG20RT
V1.1.37	2021-7-12	1. Add Inverter model: SG5.5RS-JP, SG49.5CX-JP 2. RT series machines do not support PID protection function, the model description in the protocol is deleted (measuring point 5042)
V1.1.38	2021-7-20	1. Add Inverter model: SG0.7RS-S, SG1.0RS-S, SG1.5RS-S, SG2.0RS-S, SG2.5RS-S, SG3.0RS-S SG3.0RS, SG3.6RS, SG4.0RS, SG5.0RS, SG6.0RS SG8.0RS, SG9.0RS, SG10RS, SG5.0RS-ADA 2. Modify the fault code description to be consistent with the product specification
V1.1.39	2021-10-18	1. Add Inverter model: SG320HX, SG350HX, SG125HX-JP 2. Add Inverter model: SG125CX-P2, SG25/30/33/36/40/45CX-P2 3. Add Quick grid dispatch mode(32569) 4. Add Swift grid dispatch mode(32570)

Valid for device types:

In production:

SG5.5RS-JP, SG0.7RS-S, SG1.0RS-S, SG1.5RS-S, SG2.0RS-S, SG2.5RS-S, SG3.0RS-S, SG3.0RS, SG3.6RS, SG4.0RS, SG5.0RS, SG6.0RS, SG8.0RS, SG9.0RS, SG10RS, SG5.0RS-ADA

SG3.0RT, SG4.0RT, SG5.0RT, SG6.0RT, SG7.0RT, SG8.0RT, SG10RT, SG12RT, SG15RT, SG17RT, SG20RT

SG30KTL-M, SG30KTL-M-V31, SG33KTL-M, SG36KTL-M, SG33K3J, SG49K5J, SG34KJ, LP_P34KSG, SG49.5CX-JP, SG50KTL-M-20, SG60KTL, G80KTL, SG80KTL-20, SG60KU-M

SG5KTL-MT, SG6KTL-MT, SG8KTL-M, SG10KTL-M, SG10KTL-MT, SG12KTL-M, SG15KTL-M, SG17KTL-M, SG20KTL-M,

SG80KTL-M, SG85BF, SG80HV, SG80BF, SG110HV-M, SG111HV, SG125HV, SG125HV-20
SG25CX-SA, SG30CX, SG33CX, SG40CX, SG50CX, SG36CX-US, SG60CX-US, SG75CX, SG100CX

SG100CX-JP, SG110CX, SG136TX, SG225HX, SG250HX
SG250HX-IN, SG250HX-US, SG320HX, SG350HX,SG125HX-JP
SG125CX-P2, SG25/30/33/36/40/45CX-P2

Discontinued:

SG30KTL, SG10KTL, SG12KTL, SG15KTL, SG20KTL, SG30KU, SG36KTL, SG36KU, SG40KTL,
SG40KTL-M, SG50KTL-M, SG60KTL-M, SG60KU

Statement:

All hardware versions of SG60KTL share one device type code.

1. Introduction

This communication adopts modbus RTU protocol, and applies to the communication between Sungrow PV grid-connected string inverters and the upper computer (PC) monitoring software. This protocol can read the real-time operating data and fault states of inverters.

2. Communication Interface

1) RS485

	Default setting
Address	Inverter: 1 - 247 settable PC: 1 - 247 settable
Broadcast	Yes
Baud rate	9600bit/s
Check bit	Null or settable
Data bit	8
Stop bit	1
Mode	RTU
Appliance interface	RS485-2W cable connection

2) Ethernet (optional)

Default:

- IP: 192.168.1.100;
- Sub-Net: 255.255.0.0
- Port: 502

3. Definition of Address

4. Data type

U16: 16-bit unsigned integer, big-endian

S16: 16-bit signed integer, big-endian

U32: 32-bit unsigned integer; little-endian for double-word data. Big-endian for byte data

S32: 32-bit signed integer; little-endian for double-word data. Big-endian for byte data

Example:

transmission order of U16 data 0x0102 is 01, 02

transmission order of U32 data 0x01020304 is 03, 04, 01, 02

The transmission order of multibyte data UTF-8: the high-byte data is in the front and the low-byte data is at back.

Example: transmission order of UTF-8 data ABCD is A, B, C, D.

2. Value description

The decimal parameters are transmitted as integer after expansion. For example: 10.333 KW is transmitted as 10333; 800.5 V is transmitted as 8005. Negative numbers are transmitted as complement, 0xFFFF signifying -1.

Unavailable register cannot be viewed or set. The return of unsigned number is F, For example: "0xFFFF" is the return for U16, "0xFFFFFFFF" is the return for U32; the return of signed number is the max. positive number, e.g. "0x7FFF" for S16, "0x7FFFFFFF" for S32; 0x00 for UTF-8. UTF-8 occupies 1 byte. The length of odd number is complemented by 0x00.

Example:

SG80KTL only one MPPT input,

MPPT 2 voltage (5013)

- MPPT 2 current (5014)
- MPPT 3 voltage (5015)
- MPPT 3 current (5016)
- MPPT 4 voltage (5115)
- MPPT 4 current (5116), The data for these registers are 0xFFFF.

3. Address type

Address of 3x type is read-only register, supporting the CMD code inquiry of 0x04.
 Address of 4x type is holding register, supporting the CMD code inquiry of 0x03, and CMD codes write-in of 0x10 and 0x06. CMD codes 0x10 and 0x06 support the broadcast address.
 Support Modbus error code 02 (address error), 04 (setting failure).
 Visit all registers by subtracting 1 from the register address. Example: if the address is 5000 –5001, visit it using address 4999 –5000. Entering “01 04 1387 00 02 + CRC” to check the data of address 5000 –5001.

4. Verify type

CRC16 generates polynomial 0xA001, little-endian.

3.1 Running information variable address definition (read-only register, Address type: 3X)

No.	Name	Address	Data type	Data range	Unit	Note
1	Reserved	4950 - 4951	U32			
2	Reserved	4952 - 4953	U32			
3	Reserved	4954 - 4968	U16			
4	Reserved	4969 - 4983	U16			
5	Reserved	4984 - 4989	U16			
6	SN	4990 - 4999	UTF-8			Data type :UTF-8
7	Device type code	5000	U16			See Appendix 5
8	Nominal active power	5001	U16		0.1kW	
9	Output type	5002	U16	0-two phase; 1-3P4L; 2-3P3L		

10	Daily power yields	5003	U16		0.1 kWh	
11	Total power yields	5004 - 5005	U32		kWh	
12	Total running time	5006 - 5007	U32		h	
13	Internal temperature	5008	S16		0.1 °C	
14	Total apparent power	5009 - 5010	U32		VA	Valid for inverters: SG5KTL-MT SG6KTL-MT SG8KTL-M SG10KTL-M SG10KTL-MT SG12KTL-M SG15KTL-M SG17KTL-M SG20KTL-M SG3.0RT SG4.0RT SG5.0RT SG6.0RT SG7.0RT SG8.0RT SG10RT SG12RT SG15RT SG17RT SG20RT SG33K3J SG36KTL-M SG40KTL-M SG50KTL SG50KTL-M SG60KTL SG60KTL-M SG60KU-M SG80KTL SG80KTL-M SG111HV SG125HV SG125HV-20 SG33CX SG40CX SG50CX

						SG110CX SG250HX SG30CX SG36CX-US SG60CX-US SG49.5CX-JP SG250HX-US SG250HX-IN SG25CX-SA SG100CX SG75CX SG225HX SG320HX SG125CX-P2 SG25/30/33/36/40/45CX-P2
15	MPPT 1 voltage	5011	U16		0.1V	See Appendix 5
16	MPPT 1 current	5012	U16		0.1A	
17	MPPT 2 voltage	5013	U16		0.1V	
18	MPPT 2 current	5014	U16		0.1A	
19	MPPT 3 voltage	5015	U16		0.1V	
20	MPPT 3 current	5016	U16		0.1A	
21	Total DC power	5017 - 5018	U32		W	
22	A-B line voltage/phase A voltage	5019	U16		0.1 V	Output type (address: 5002) is 1: upload phase voltage; 2: upload line voltage Except SG5.5RS-JP
23	B-C line Voltage/phase B Voltage	5020	U16		0.1 V	Output type (address: 5002) is 1: upload phase voltage; 2: upload line voltage Except SG5.5RS-JP
24	C-A line Voltage/phase C Voltage	5021	U16		0.1 V	Output type (address: 5002) is 1: upload phase voltage; 2: upload line voltage Except SG5.5RS-JP
25	Phase A current	5022	U16		0.1 A	Except SG5.5RS-JP
26	Phase B	5023	U16		0.1 A	Except SG5.5RS-JP

	current					
27	Phase C current	5024	U16		0.1 A	Except SG5.5RS-JP
28	Reserved	5025 - 5026	U32			
29	Reserved	5027 - 5028	U32			
30	Reserved	5029 - 5030	U32			
31	Total active power	5031 - 5032	U32		W	
32	Total reactive power	5033-5034	S32		Var	
33	Power factor	5035	S16		0.001	>0 means leading <0 means lagging
34	Grid frequency	5036	U16		0.1 Hz	
35	Reserved	5037	U16			
36	Work state	5038	U16	See Appendix 1		Data of address 5039 - 5045 are additional
	Fault/Alarm time: Year	5039	U16			Fault/Alarm time and Fault/Alarm code (5039 - 5045) are valid only when the device work state is fault (0x5500) or alarm (0x9100). Except SG5.5RS-JP , SG0.7/1.0/1/5/2.0/2.5/3.0RS-S, SG3.0/3.6/4.0/5.0/6.0RS, SG5.0RS-ADA, SG8.0/9.0/10RS
	Fault/Alarm time: Month	5040	U16			
	Fault/Alarm time: Day	5041	U16			
	Fault/Alarm time: Hour	5042	U16			
	Fault/Alarm time: Minute	5043	U16			
	Fault/Alarm time: Second	5044	U16			
	Fault/Alarm code 1	5045	U16	See Appendix 3		
	Reserved	5046 - 5048	U16			
37	Nominal reactive power	5049	U16		0.1kVar	
38	Reserved	5050 - 5070	U32			
39	Array insulation resistance	5071	U16	1 - 20000(0xFFFF: invalid)	1kΩ	

40	Reserved	5072	U16			
41	Reserved	5073-5076				
42	Active Power Regulation Setpoint	5077 - 5078	U32		1w	Except SG5.5RS-JP
43	Reactive Power Regulation Setpoint	5079-5080	S32		1Var	
44	Work state	5081 - 5082	U32			See Appendix 2 Except SG5.5RS-JP
45	Meter power	5083~5084	S32		1w	Valid for inverters: SG5KTL-MT SG6KTL-MT SG8KTL-M SG10KTL-M SG10KTL-MT SG12KTL-M SG15KTL-M SG17KTL-M SG20KTL-M Note: Country set to Europe Area.
46	Meter A phase power	5085~5086	S32		1w	
47	Meter B phase power	5087~5088	S32		1w	
48	Meter C phase power	5089~5090	S32		1w	
49	Load power	5091~5092	S32		1w	
50	Daily export energy	5093~5094	U32		0.1kWh	
51	Total export energy	5095~5096	U32		0.1kWh	
52	Daily import energy	5097~5098	U32		0.1kWh	
53	Total import energy	5099~5100	U32		0.1kWh	
54	Daily direct energy consumption	5101~5102	U32		0.1kWh	
55	Total direct energy consumption	5103~5104	U32		0.1kWh	
56	Reserved	5105 - 5112				
57	Daily running time	5113	U16		1min	
58	Present country	5114	U16			
59	MPPT 4 voltage	5115	U16		0.1V	See Appendix 5 Except SG5.5RS-JP
60	MPPT 4 current	5116	U16		0.1A	
61	MPPT 5	5117	U16		0.1V	

	voltage					
62	MPPT 5 current	5118	U16		0.1A	
63	MPPT 6 voltage	5119	U16		0.1V	
64	MPPT 6 current	5120	U16		0.1A	
65	MPPT 7 voltage	5121	U16		0.1V	
66	MPPT 7 current	5122	U16		0.1A	
67	MPPT 8 voltage	5123	U16		0.1V	
68	MPPT 8 current	5124	U16		0.1A	
69	Reserved	5125				
70	Reserved	5126 - 5127				
71	Monthly power yields	5128 - 5129	U32		0.1kWh	
72	MPPT 9 voltage	5130	U16		0.1V	See Appendix 5 Except SG5.5RS-JP
73	MPPT 9 current	5131	U16		0.1A	
74	MPPT 10 voltage	5132	U16		0.1V	
75	MPPT 10 current	5133	U16		0.1A	
76	MPPT 11 voltage	5134	U16		0.1V	
77	MPPT 11 current	5135	U16		0.1A	
78	MPPT 12 voltage	5136	U16		0.1V	
79	MPPT 12 current	5137	U16		0.1A	
80	Reserved	5138 - 5139	U16			
81	Reserved	5140				
82	Reserved	5141				
83	Reserved	5142				
84	Reserved	5143				
85	Total power yields	5144 - 5145	U32		0.1kWh	(Display accuracy increased to 0.1kWh)

						Valid for inverters: SG5KTL-MT SG6KTL-MT SG8KTL-M SG10KTL-M SG10KTL-MT SG12KTL-M SG15KTL-M SG17KTL-M SG20KTL-M SG3.0RT SG4.0RT SG5.0RT SG6.0RT SG7.0RT SG8.0RT SG10RT SG12RT SG15RT SG17RT SG20RT SG80KTL-M SG111HV SG125HV SG125HV-20 SG33CX SG40CX SG50CX SG110CX SG250HX SG30CX SG36CX-US SG60CX-US SG49.5CX-JP SG250HX-US SG250HX-IN SG25CX-SA SG100CX SG75CX SG225HX SG320HX SG125CX-P2 SG25/30/33/36/40/45CX-P2
86	Negative voltage to the	5146	S16	-15000~15000	0.1V	Except SG5.5RS-JP

	ground					
87	Bus voltage	5147	U16	0 - 15000	0.1V	
88	Grid frequency	5148	U16		0.01Hz	<p>(Display accuracy increased to 0.01Hz)</p> <p>Valid for inverters:</p> <ul style="list-style-type: none"> SG5KTL-MT SG6KTL-MT SG8KTL-M SG10KTL-M SG10KTL-MT SG12KTL-M SG15KTL-M SG17KTL-M SG20KTL-M SG3.0RT SG4.0RT SG5.0RT SG6.0RT SG7.0RT SG8.0RT SG10RT SG12RT SG15RT SG17RT SG20RT SG80KTL-M SG111HV SG125HV SG125HV-20 SG33CX SG40CX SG50CX SG110CX SG250HX SG30CX SG36CX-US SG60CX-US SG49.5CX-JP SG250HX-US SG250HX-IN SG25CX-SA SG100CX SG75CX SG225HX SG320HX/SG350HX/SG125HX-

						JP SG125CX-P2 SG25/30/33/36/40/45CX-P2
89	Reserved	5149	U16	0~15000	0.1V	
90	PID work state	5150	U16	2: PID Recover Operation 4: Anti-PID Operation 8: PID Abnormity		Valid for inverters: SG5KTL-MT SG6KTL-MT SG8KTL-M SG10KTL-M SG10KTL-MT SG12KTL-M SG15KTL-M SG17KTL-M SG20KTL-M SG3.0RT SG4.0RT SG5.0RT SG6.0RT SG7.0RT SG8.0RT SG10RT SG12RT SG15RT SG17RT SG20R SG80KTL-M SG125HV SG125HV-20 SG80KTL SG33CXSG40CX SG50CX SG110CX SG100CX SG75CX SG136TX SG250HX SG30CX SG36CX-US SG60CX-US SG49.5CX-JP SG250HX-US SG250HX-IN SG25CX-SA SG225HX SG320HX/SG350HX/SG125HX-

						JP SG125CX-P2 SG25/30/33/36/40/45CX-P2 SG0.7RS-S SG1.0RS-S SG1.5RS-S SG2.0RS-S SG2.5RS-S SG3.0RS-S SG3.0RS SG3.6RS SG4.0RS SG5.0RS SG6.0RS SG8.0RS SG9.0RS SG10RS SG5.0RS-ADA
91	PID alarm code	5151	U16	432:PID resistance abnormal 433:PID function abnormal 434:PID overvoltage/overcurrent protection		See Appendix 4
92	Reserved	5152	U16			
93	Reserved	5153-7012				
1	String 1 current	7013	U16		0.01A	Before checking the current information of one input, please make sure the hardware supports this function. If parameter can be viewed in the LCD panel or APP software(default menu-running information), the corresponding address is readable. Number of strings, please see Appendix 5 Except SG5.5RS-JP
2	String 2 current	7014	U16		0.01A	
3	String 3 current	7015	U16		0.01A	
4	String 4 current	7016	U16		0.01A	
5	String 5 current	7017	U16		0.01A	
6	String 6 current	7018	U16		0.01A	
7	String 7 current	7019	U16		0.01A	
8	String 8 current	7020	U16		0.01A	

	current				
9	String 9 current	7021	U16		0.01A
10	String 10 current	7022	U16		0.01A
11	String 11 current	7023	U16		0.01A
12	String 12 current	7024	U16		0.01A
13	String 13 current	7025	U16		0.01A
14	String 14 current	7026	U16		0.01A

a) Parameter setting address definition (holding register, Address type: 4X)

No.	Name	Address	Data type	Data range	Unit	Note
1	System clock: Year	5000	U16			Receive time synchronization setting of the monitoring system
2	System clock: Month	5001	U16			
3	System clock: Day	5002	U16			
4	System clock: Hour	5003	U16			
5	System clock: Minute	5004	U16			
6	System clock: Second	5005	U16			
7	Start/Stop	5006	U16	0xCF (Start) 0xCE (Stop)		
8	Power limitation switch	5007	U16	0xAA: Enable; 0x55: Disable		
9	Power limitation setting	5008	U16	See Appendix 5	0.1%	Available when the power limitation switch (5007) is enabled
10	Reserved	5009	U16			Valid for inverters: SG5KTL-MT SG6KTL-MT SG8KTL-M SG10KTL-M SG10KTL-MT SG12KTL-M SG15KTL-M SG17KTL-M SG20KTL-M Note: Country set to Europe Area. Except SG0.7/1.0/1/5/2.0/2.5/3.0RS-S, SG3.0/3.6/4.0/5.0/6.0RS, SG5.0RS-ADA, SG8.0/9.0/10RS whose address is 5012 - 5014
11	Export power limitation	5010	U16	0xAA: Enable; 0x55: Disable		
12	Export power limitation value	5011	U16	0-Rated active power		
13	Current transformer output current	5012	U16	1-100	A	
14	Current transformer range	5013	U16	1-10000	A	
15	Current transformer	5014	U16	0- Internal 1- External		
16	Export power limitation percentage	5015	U16	0~1000	0.1%	
17	Installed PV Power	5016	U16	0-30000	0.01KW	

18	Power factor setting	5019	S16	-1000 - -800 800 - 1000	0.001	Available when the reactive power adjustment switch (5036) is set to power factor setting valid (0xA1) > 0 means leading < 0 means lagging
19	100% Scheduling to Achieve Active Overload	5020	U16	0xAA: Enable; 0x55: Disable		Valid for inverters: SG33CX SG40CX SG50CX SG75CX SG110CX SG136TX SG250HX SG320HX SG30CX SG36CX-US SG60CX-US SG49.5CX-JP SG250HX-US SG250HX-IN SG225HX SG250HX SG320HX/ SG350HX /SG125HX-JP SG125CX-P2 SG25/30/33/36/40/45CX-P2 SG25CX-SA SG100CX SG3.0RT SG4.0RT SG5.0RT SG6.0RT SG7.0RT SG8.0RT SG10RT SG12RT SG15RT SG17RT SG20RT NOTE: If scheduling command is 0~99%, inverters will generate power according to the command value. If scheduling command is over 100%, inverters will always generate its max power

20	Reserved	5021 - 5033	U16		
21	Night SVG Switch	5035	U16	0xAA: Enable; 0x55: Disable	<p>Valid for inverters:</p> <p>SG3.0RT SG4.0RT SG5.0RT SG6.0RT SG7.0RT SG8.0RT SG10RT SG12RT SG15RT SG17RT SG20RT SG80KTL-M SG125HV-20 SG33CX SG40CX SG50CX SG110CX SG136TX SG250HX SG320HX/SG350HX/SG125HX-JP SG125CX-P2 SG25/30/33/36/40/45CX-P2 SG30CX SG36CX-US SG60CX-US SG49.5CX-JP SG250HX-US SG250HX-IN SG225HX SG250HX SG25CX-SA SG100CX SG75CX</p>
22	Reactive power adjustment mode	5036	U16	0x55: OFF, power factor returns to 1, reactive power percentage returns to 0; 0xA1: power factor setting valid,	The SG5.5RS-JP doesn't support 0xA2, 0xA3, 0xA4

				Reactive power percentage returns to 0; 0xA2: Reactive power percentage setting valid, power factor returns to 1; 0xA3: Enable Q(P) curve configuration; 0xA4: Enable Q(U) curve configuration		
23	Reactive power percentage setting	5037	S16	0 - 1000 0 - -1000	0.1%	Available when the reactive power adjustment switch (5036) is set to Reactive power percentage setting valid (0xA2)
24	Reserved	5038				
25	Power limitation adjustment	5039	U16	See Appendix 5	0.1kW	Available when the power limitation switch (5007) is enabled Except SG5.5RS-JP
26	Reactive power adjustment	5040	S16	See Appendix 5	0.1kVar	Available when the reactive power adjustment switch (5036) is set to Reactive power percentage setting valid (0xA2) Except SG0.7/1.0/1/5/2.0/2.5/3.0RS-S, SG3.0/3.6/4.0/5.0/6.0RS, SG5.0RS-ADA, SG8.0/9.0/10RS
27	PID Recovery	5041	U16	0xAA: Enable; 0x55: Disable		Valid for inverters: SG5KTL-MT (EU excluded) SG6KTL-MT (EU excluded) SG8KTL-M (EU excluded) SG10KTL-M (EU excluded) SG10KTL-MT (EU excluded) SG12KTL-M (EU excluded) SG15KTL-M (EU excluded) SG17KTL-M (EU excluded) SG20KTL-M (EU excluded) SG3.0RT SG4.0RT SG5.0RT

						SG6.0RT SG7.0RT SG8.0RT SG10RT SG12RT SG15RT SG17RT SG20RT SG80KTL-M SG125HV SG125HV-20 SG80KTL SG33CX SG40CX SG50CX SG100CX SG75CX SG110CX SG136TX SG250HX SG320HX SG30CX SG36CX-US SG60CX-US SG49.5CX-JP SG250HX-US SG250HX-IN SG25CX-SA SG225HX SG320HX/SG350HX/SG125HX-JP SG125CX-P2 SG25/30/33/36/40/45CX-P2
28	Anti-PID	5042	U16	0xAA: Enable; 0x55: Disable		Valid for inverters: SG125HV SG125HV-20 SG250HX SG250HX-US SG250HX-IN SG136TX/SG100CX-JP SG225HX SG320HX/SG350HX/SG125HX-JP Except SG0.7/1.0/1/5/2.0/2.5/3.0RS- S, SG3.0/3.6/4.0/5.0/6.0RS, SG5.0RS-ADA, SG8.0/9.0/10RS
29	Full-Day PID	5043	U16	0xAA: Enable;		Valid for inverters:

	Suppression			0x55: Disable		HX Except SG0.7/1.0/1/5/2.0/2.5/3.0RS-S, SG3.0/3.6/4.0/5.0/6.0RS, SG5.0RS-ADA, SG8.0/9.0/10RS
30	Reserved	5043 - 5047				
31	Q(P) curve 1	5048-5077		See Appendix 6 Note: The reactive power adjustment switch (5036) is set to Enable Q(P) curve (0xA3)		Except inverters :CX/HX/TX
32	Q(U) curve 1	5078-5115		See Appendix 7 Note: The reactive power adjustment switch (5036) is set to Enable Q(U) curve (0xA4)		Except inverters :CX/HX/TX
33	Q(P) curve 2	5116-5134		See Appendix 8 Note: The reactive power adjustment switch (5036) is set to Enable Q(P) curve (0xA3)		Valid for inverters: SG3.0RT SG4.0RT SG5.0RT SG6.0RT SG7.0RT SG8.0RT SG10RT SG12RT SG15RT SG17RT SG20RT SG33CX/SG40CX/SG50CX/ SG110CX/ SG250HX/ SG30CX/SG36CX-US/ SG60CX-US/SG49.5CX-JP /SG250HX-US SG250HX-IN/SG225HX/ SG25CX-SA SG100CX/SG75CX
34	Q(U) curve 2	5135-5154		See Appendix 9 Note: The reactive power adjustment switch (5036) is set to Enable Q(U) curve (0xA4)		Valid for inverters: SG33CX/SG40CX/SG50CX/ SG110CX/ SG250HX/ SG30CX//SG36CX-US/ SG60CX-US/ SG49.5CX-JP /SG250HX-US SG250HX-IN/SG225HX/ SG25CX-SA

						SG100CX/SG75CX
35	Reserved	5155-5199				
36	Quick grid dispatch mode	32569	U16	0xAA: Enable; 0x55: Disable		Valid for inverters: SG320HX SG350HX
37	Swift grid dispatch mode	32570	U16	0xAA: Enable; 0x55: Disable		Valid for inverters: SG320HX SG350HX

Appendix

Appendix 1 Device Work State 1

Device state (register 5038)			
State	Value read by register 5038	Paraphrase	Grid-connected power generation
Run	0x0	After being energized, inverter tracks the PV arrays' maximum power point (MPP) and converts the DC power into AC power. This is the normal operation mode	Yes
Stop	0x8000	Inverter is stopped.	No
Key stop	0x1300	Inverter will stop operation by manually "stop" via app. In this way, inverter internal DSP stops. To restart the inverter, manually start via app	No
Emergency Stop	0x1500		No
Standby	0x1400	Inverter enters standby mode when DC side input is insufficient. In this mode inverter will wait within the standby duration.	No
Initial standby	0x1200	The inverter is in the initial power-on standby state.	No
Starting	0x1600	The inverter is initializing and synchronizing with the grid	No
Alarm run	0x9100	Warning information is detected.	Yes
Derating run	0x8100	The inverter derates actively due to environmental factors such as temperature or altitude	Yes
Dispatch run	0x8200	The inverter runs according to the scheduling instructions received from the monitoring background	Yes
Fault	0x5500	If a fault occurs, inverter will automatically stop operation, and disconnect the AC relay. The fault information will be displayed in the app. Once the fault is removed in recovery time, inverter will automatically resume running.	No
Communicate fault	0x2500		Unconfirmed
Uninitialized	0x1111		No

Appendix 2 Device Work State2

Work State (5081 - 5082)		Note
State	Corresponding BIT in address 5081-5082	
Run	0	Total run state bit BIT17
Stop	1	1

Key stop	3	3
Emergency Stop	5	5
Standby	4	4
Initial standby	2	2
Starting	6	6
Alarm run	10	Total run state bit BIT17
Derating run	11	Total run state bit BIT17
Dispatch run	12	Total run state bit BIT17
Fault	9	Total fault state bit BIT18
Communicate fault	13	Total fault state bit BIT18
Total run bit (device is grid-connected running)	17	
Total fault bit (device is in fault stop state)	18	

Appendix 3 Device Fault Code (Note: Please refer to the product user manual for handling measures)

Fault code	Fault name
2, 3, 14, 15	Grid Overvoltage
4, 5	Grid Undervoltage
8	Grid Overfrequency
9	Grid Underfrequency
10	Grid Power Outage
12	Excess Leakage Current
13	Grid Abnormal
17	Grid Voltage Imbalance
28, 29, 208, 448-479	PV Reserve Connection Fault
532-547, 564-579	PV Reverse Connection Alarm
548-563, 580-595	PV Abnormal Alarm
37	Excessively High Ambient Temperature
43	Excessively Low Ambient Temperature
39	Low System Insulation Resistance
106	Grounding Cable Fault
88	Electric Arc Fault
84	Reverse Connection Alarm of the Meter/CT
514	Meter Communication Abnormal Alarm
323	Grid Confrontation
75	Inverter Parallel Communication Alarm
7, 11, 16, 19 - 25, 30 - 34, 36, 38, 40 - 42, 44 - 50, 52 - 58, 60 - 68, 85, 87, 92, 93, 100 - 105, 107 - 114, 116 - 124, 200 - 211, 248 - 255, 300 - 322, 324 - 326, 401 - 412,	System Fault

600 - 603, 605, 608, 612, 616, 620, 622 - 624, 800, 802, 804, 807, 1096 - 1122	
59, 70 - 72, 74, 76, 82, 83, 89, 77 - 81, 216 - 218, 220 - 231, 432 - 434, 500 - 513, 515 - 518, 900, 901, 910, 911	System Alarm
264-283	MPPT Reverse Connection
332-363	Boost Capacitor Overvoltage Alarm
364-395	Boost Capacitor Overvoltage Fault
1548-1579	String Current Reflux

Appendix 4 PID alarm code

LCD or APP display (decimal)	Communication send data (hexadecimal)	Description	Note
432	0x01B0	PID impedance abnormality	<ol style="list-style-type: none"> 1. Check to ensure that the inverter is equipped with the PID regulation function. 2. Check whether the ISO impedance protection value is excessively high through the LCD or the APP, so as to ensure the requirements are met. 3. Check whether the positive and negative insulation resistances to earth of the battery panel are excessively low. 4. Please contact SUNGROW if the fault still exists.
433	0x01B1	PID function abnormality	<ol style="list-style-type: none"> 1. Check to ensure that the inverter is equipped with the PID regulation function. 2. Check device operating environment and ensure the transformer-side phase line or N line impedance to ground is normal. 3. Please contact SUNGROW if the fault still exists.
434	0x01B2	PID overvoltage/overcurrent protection	<ol style="list-style-type: none"> 1. Check if the actual ISO impedance is excessively large (greater than 1.5M ohms). 2. Check whether the set PID control duty cycle is excessively large. 3. Please contact SUNGROW if the fault still exists.

Appendix 5 Device Information(Note: If the value of string/MPPT is 1, it indicates that no string information (7013-7036) is uploaded to the read-only memory.)

Model	Type code	MPPT	String/MPPT	Power limited range(0.1%)	Power limited range (0.1kW)	Reactive power limited range(0.1kvar)
SG30KTL	0x27	2	4	0-1100	0-330	-150-150
SG10KTL	0x26	2	3	0-1100	0-110	-50-50
SG12KTL	0x29	2	3	0-1100	0-132	-60-60
SG15KTL	0x28	2	3	0-1100	0-165	-75-75
SG20KTL	0x2A	2	3	0-1100	0-220	-100-100
SG30KU	0x2C	2	5	0-1100	0-330	-150-150
SG36KTL	0x2D	2	5	0-1100	0-396	-180-180
SG36KU	0x2E	2	5	0-1100	0-396	-180-180
SG40KTL	0x2F	2	4	0-1100	0-396	-180-180
SG40KTL-M	0x0135	3	3	0-1100	0-440	-200-200
SG50KTL-M	0x011B	4	3	0-1100	0-550	-250-250
SG60KTL-M	0x0131	4	4	0-1100	0-660	-300-300
SG60KU	0x0136	1	8	0-1100	0-660	-300-300
SG30KTL-M	0x0141	3	3;3;2	0-1000	0-300	-150-150
SG30KTL-M-V31	0x70	3	3;3;2	0-1000	0-300	-150-150
SG33KTL-M	0x0134	3	3;3;2	0-1100	0-363	-165-165
SG36KTL-M	0x74	3	3;3;2	0-1000	0-360	-180-180
SG33K3J	0x013D	3	3	0-1000	0-333	-166-166
SG49K5J	0x0137	4	3	0-1000	0-495	-247-247
SG34KJ	0x72	2	4	0-1000	0-340	-170-170
LP_P34KSG	0x73	1	4	0-1000	0-340	-170-170
SG50KTL-M-20	0x011B	4	3	0-1100	0-550	-250-250
SG60KTL	0x010F	1	14	0-1100	0-660	-300-300
SG80KTL	0x0138	1	18	0-1000	0-800	-400-400
SG80KTL-20	0x0138	1	18	0-1000	0-800	-400-400
SG60KU-M	0x0132	4	4	0-1100	0-660	-300-300
SG5KTL-MT	0x0147	2	1	0-1100	0-55	-25-25
SG6KTL-MT	0x0148	2	1	0-1100	0-66	-30-30
SG8KTL-M	0x013F	2	1	0-1100	0-88	-40-40
SG10KTL-M	0x013E	2	1	Default: 0-1100 If country is Germany, range is 0-1000	Default: 0-110 If country is Germany, range is 0-100	-50-50
SG10KTL-MT	0x2C0F	2	2	0-1100	0-110	-50-50
SG12KTL-M	0x013C	2	2	0-1100	0-132	-60-60
SG15KTL-M	0x0142	2	2	0-1100	0-165	-75-75

SG17KTL-M	0x0149	2	2	0-1100	0-187	-85-85
SG20KTL-M	0x0143	2	2	0-1100	0-220	-100-100
SG80KTL-M	0x0139	4	4	0-1100	0-880	-400-400
SG111HV	0x014C	1	1	0-1000	0-1110	-555-555
SG125HV	0x013B	1	1	0-1000	0-1250	-625-625
SG125HV-20	0x2C03	1	1	0-1000	0-1250	-625-625
SG30CX	0x2C10	3	2	0-1000	0-299	-179~179
SG33CX	0x2C00	3	2	0-1100	0-363	-218~218
SG36CX-US	0x2C0A	3	2	0-1100	0-360	-216~216
SG40CX	0x2C01	4	2	0-1100	0-440	-264~264
SG50CX	0x2C02	5	2	0-1100	0-550	-330~330
SG60CX-US	0x2C0B	5	2	0-1100	0-600	-360~360
SG49.5CX-JP	0x2C21	6	2	0-1000	0-495	-297 ~ 297
SG110CX	0x2C06	9	2	0-1100	0-1100	-660~660
SG250HX	0x2C0C	12	2	0-1110	0-2500	-1500~1500
SG250HX-US	0x2C11	12	2	0-1110	0-2500	-1500~1500
SG100CX	0x2C12	12	2	0-1000	0-1000	-660~660
SG100CX-JP	0x2C12	12	2	0-1000	0-1000	-660~660
SG250HX-IN	0x2C13	12	2	0-1250	0-2500	-1500~1500
SG25CX-SA	0x2C15	3	2	0-1100	0-275	-165~165
SG75CX	0x2C22	9	2	0-1000	0-750	-450~450
SG3.0RT	0x243D	2	1	0-1100	0-33	-15~15
SG4.0RT	0x243E	2	1	0-1100	0-44	-20~20
SG5.0RT	0x2430	2	1	Default: 0-1100 (Germany, Belgium, Australia: 0-1000)	Default: 0-55 (Germany, Belgium, Australia: 0-50)	-25~25
SG6.0RT	0x2431	2	1		Default: 0-66 (Germany, Belgium, Australia: 0-60)	-30~30
SG7.0RT	0x243C	2	2;1		Default: 0-77 (Germany, Belgium: 0-70; Australia: 0-69.99)	-35~35
SG8.0RT	0x2432	2	2;1		Default: 0-88 (Germany, Belgium, Australia: 0-80)	-40~40
SG10RT	0x2433	2	2;1		Default: 0-110 (Germany, Belgium, Australia: 0-110)	-50~50
SG12RT	0x2434	2	2;1		Default: 0-132	-60~60

					(Germany, Belgium, Australia: 0-120)	
SG15RT	0x2435	2	2		Default: 0-165 (Germany, Belgium, Australia: 0-150)	-75~75
SG17RT	0x2436	2	2		Default: 0-187 (Germany, Belgium, Australia: 0-170)	-85~85
SG20RT	0x2437	2	2		Default: 0-220 (Germany, Belgium, Australia: 0-200)	-100~100
SG5.5RS-JP	0x260D	3	3	0-1000	0-55	-35 - 35
SG2.0RS-S	0x2600	1	1	0-600	0-20	-12~12
SG2.5RS-S	0x2601	1	1	0-600	0-25	-15~15
SG3.0RS-S	0x2602	1	1	0-600	0-30	-18~18
SG3.0RS	0x2603	2	1	0-600	0-30	-18~18
SG3.6RS	0x2604	2	1	0-600	0-36	-21~21
SG4.0RS	0x2605	2	1	0-600	0-40	-24~24
SG5.0RS	0x2606	2	1	0-600	0-50	-30~30
SG6.0RS	0x2607	2	1	0-600	0-60	-36~36
SG8.0RS	0x2608	3	1	0-600	0-80	-48~48
SG9.0RS	0x260E	3	1	0-600	0-90	-54~54
SG10RS	0x2609	3	1	0-600	0-100	-60~60
SG5.0RS-ADA	0x260F	3	1	0-600	0-50	-30~30
SG125HX-JP	0x2C25	12	2	0-1100	0-1250	-1500 - 1500
SG320HX	0x2C26	12	2	0-1100	0-3200	-1500 - 1500
SG350HX	0x2C27	12	2	0-1100	0-3500	-1500 - 1500
SG125CX-P2	0x2C2D	12	2	0-1100	0-1250	-750 - 750
SG25CX-P2	0x2C33	3	2	0-1100	0-275	-165-165
SG30CX-P2	0x2C34	3	2	0-1100	0-330	-198-198
SG33CX-P2	0x2C35	3	2	0-1100	0-363	-217-217
SG36CX-P2	0x2C36	4	2	0-1100	0-396	-237-237
SG40CX-P2	0x2C37	4	2	0-1100	0-440	-264-264
SG50CX-P2	0x2C32	4	2	0-1100	0-550	-330-330

Appendix 6 Q(P) Curve 1

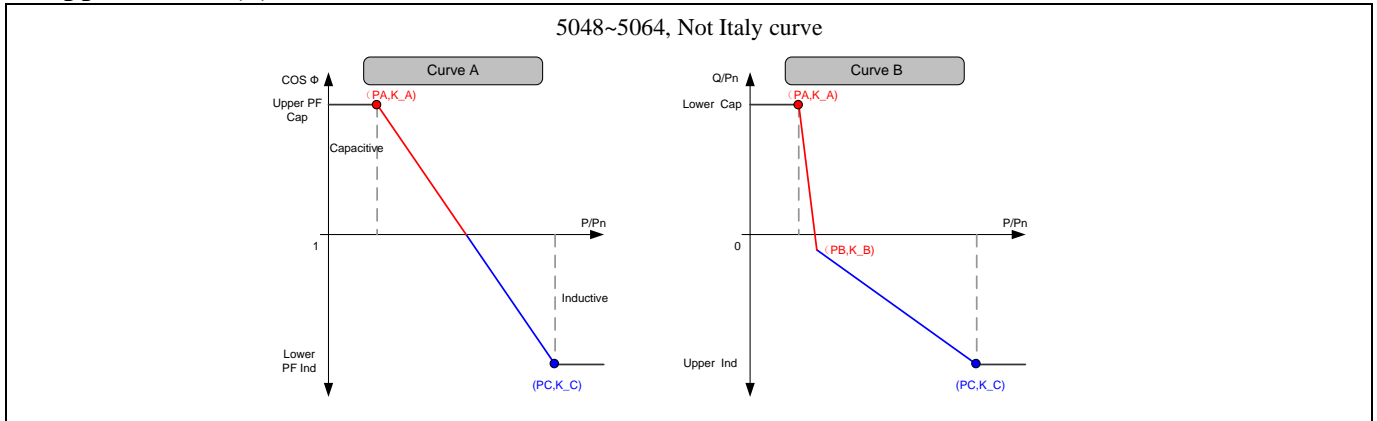

Curve	5048	U16	0 - 1, 0 Curve A, 1 Curve B		Curve A: $PA < PC$ Curve B: $(PA \leq PB \leq PC, \text{ but } PA \neq PC)$ and $(KA \leq KB \leq KC)$ or $KA \geq KB \geq KC, \text{ but } KA \neq KC)$
PB	5049	U16	200-1000 Curve B is valid	0.1%	
KB	5050	S16	-500-500 Curve B is valid	0.001	
PA(Lower Power)	5051	U16	Curve A: 0~500 Curve B: 100-1000	0.1%	
PC(Upper Power)	5052	U16	Curve A: 500~1000 Curve B: 200-1000	0.1%	
KA(Upper limit-PF)	5053	S16	Curve A: 900~1000 Curve B: -500-500	0.001	
KC(Lower limit-PF)	5054	S16	Curve A: 900~1000 Curve B: -500-500	0.001	
Reserved	5055-5064				

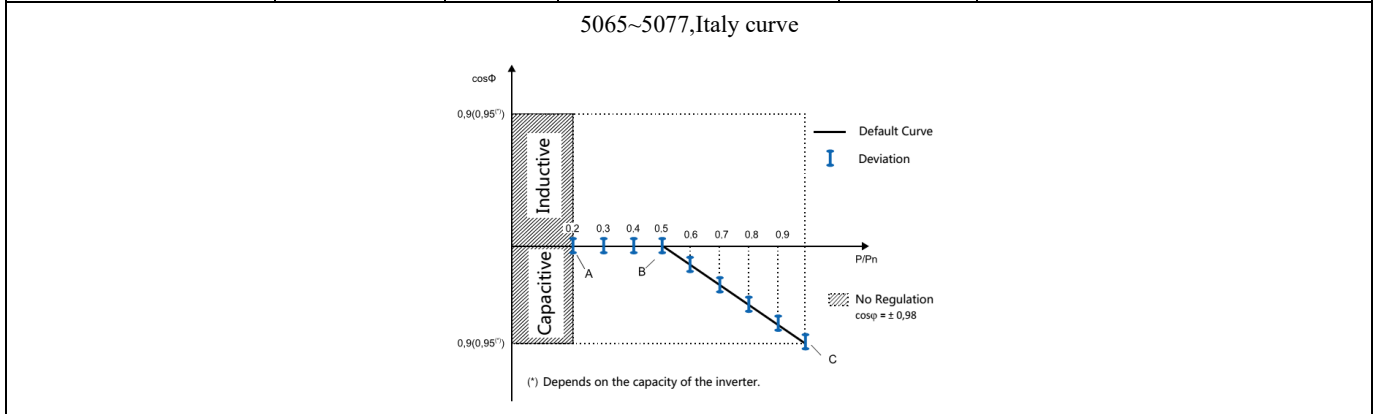

powerA	5065	U16	200~1000	0.1%	powerA ≤ powerB < powerC
powerB	5066	U16	200~1000	0.1%	
powerC	5067	U16	200~1000	0.1%	
pf_max	5068	U16	900~1000	0.001	
Uin	5069	U16	1000~1100	0.1%	Uin > Uout
Uout	5070	U16	900~1000	0.1%	
Reserved	5071~5077	U16			

Appendix 7 Q(U) Curve 1

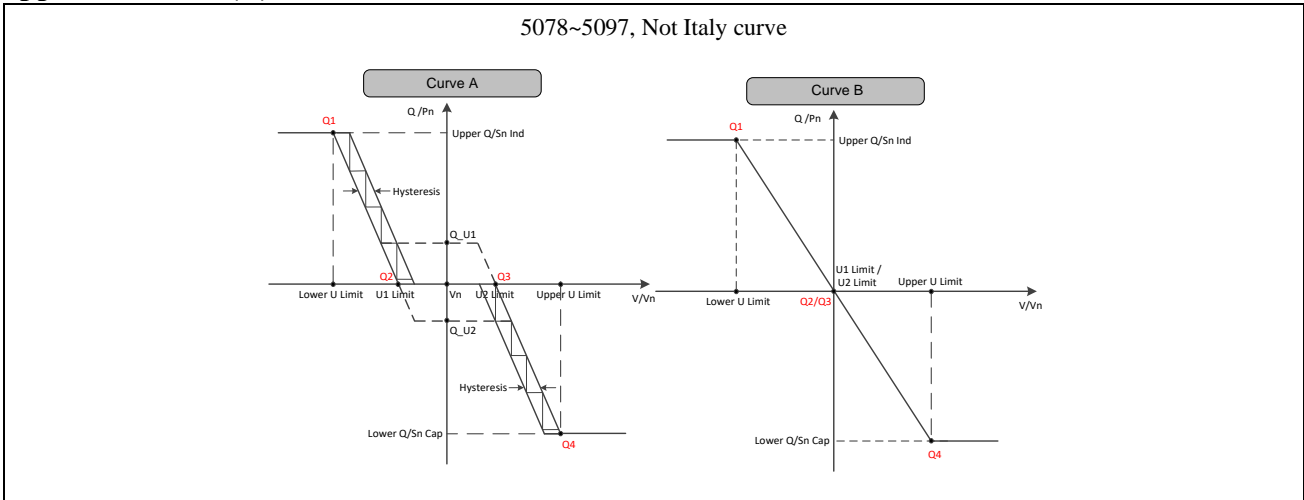

Curve	5078	U16	0-1, 0 Curve A, 1 Curve B		Curve A: (U1Limit+Hysteresis<U2 Limit- Hysteresis) and (-Upper Q/Sn<=Q_U1<= Lower Q/Sn) and (-Upper Q/Sn<=Q_U2<= Lower Q/Sn) Curve: U1 Limit == U2 Limit
Q_U1	5079	S16	-500-500, Curve A is valid	0.1%	
Q_U2	5080	S16	-500-500, Curve A is valid	0.1%	
Lower ULimit	5081	U16	800~1000	0.1%	
Upper U Limit	5082	U16	1000~1200	0.1%	
U1 Limit	5083	U16	900~1100	0.1%	
U2 Limit	5084	U16	900~1100	0.1%	
Hysteresis	5085	U16	0~50 Curve A is valid	0.1%	
Lower Q/Sn	5086	U16	(Ind) 0~ 500	0.1%	
Upper Q/Sn	5087	U16	(Cap) 0~500	0.1%	
Reserved	5088-5097				

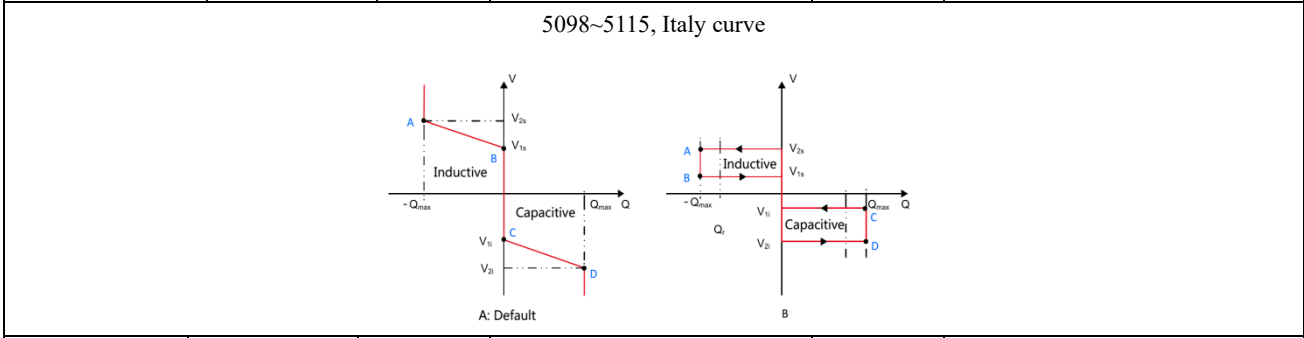

V1i (Italy)	5098	U16	900~1100	0.1%	
V2i (Italy)	5099	U16	900~1100	0.1%	V2i < V1i < V1s < V2s
V1s (Italy)	5100	U16	900~1100	0.1%	
V2s	5101	U16	900~1100	0.1%	

(Italy)					
Qmax (Italy)	5102	U16	500~1000	0.001	
Pin (Italy)	5103	U16	200~1000	0.1%	Pin > Pout
Pout (Italy)	5104	U16	10~200	0.1%	
Curve (Italy)	5105	U16	0-1, 0 Curve A, 1 Curve B		
Reserved	5106~5115				

Appendix 8 Q(P) Curve 2^①

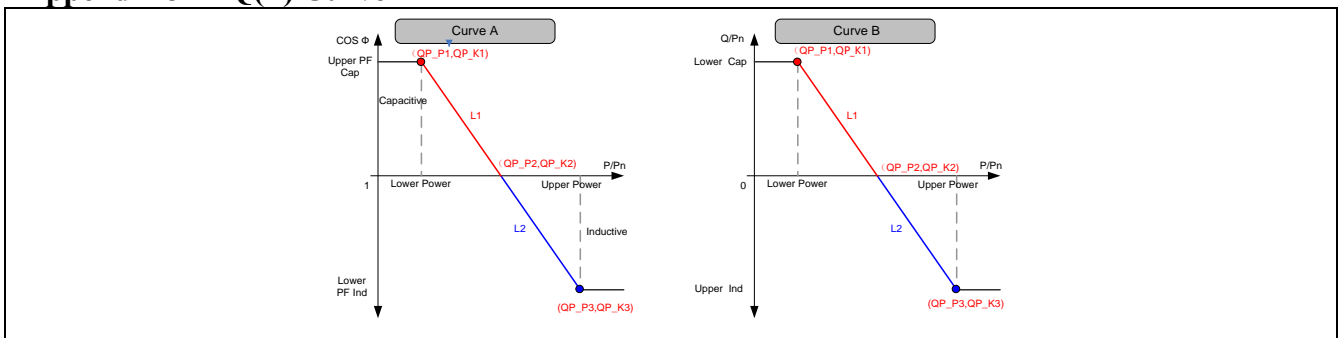

Q(P) Curve	5116	U16	0-1 0: Curve A 1: Curve B		<p>1. $QP_P1 \leq QP_P2 < QP_P3$ 2. If $QP_P1 = QP_P2$, $QP_K1 = QP_K2$</p> <p>QP_EnableMode: Enter and exit Q (P) mode conditions, 0xAA, unconditional entry and exit; 0x55, conditional entry and exit: the voltage is higher than $QP_EnterVoltageRatio$, the voltage is lower than $U_{outQP_ExitVoltageRatio}$, and the power is lower than $QP_ExitPowerRatio$</p>
QP_P1	5117	U16	100~1000	0.1%	
QP_P2	5118	U16	200~1000	0.1%	
QP_P3	5119	U16	200~1000	0.1%	
QP_K1	5120	S16	Curve A: 800~1000 Curve B: If support Overload -660-660 If not -600-600	0.001	
QP_K2	5121	S16	Curve A: 800~1000	0.001	

			If support Overload -660-660 If not -600-600		
QP_K3	5122	S16	Curve A: 800~1000 If support Overload -660-660 If not -600-600	0.001	
QP_EnterVoltageRatio	5123	U16	1000~1100	0.1%	
QP_ExitVoltageRatio	5124	U16	900~1000	0.1%	
QP_ExitPowerRatio	5125	U16	10-200	0.1%	
QP_EnableMode	5126	U16	0xAA Yes 0x55 No		
Reserved	5127-5134	U16			

① Except SG0.7/1.0/1/5/2.0/2.5/3.0RS-S, SG3.0/3.6/4.0/5.0/6.0RS, SG5.0RS-ADA, SG8.0/9.0/10RS

Appendix 9 Q(U) Curve 2^①

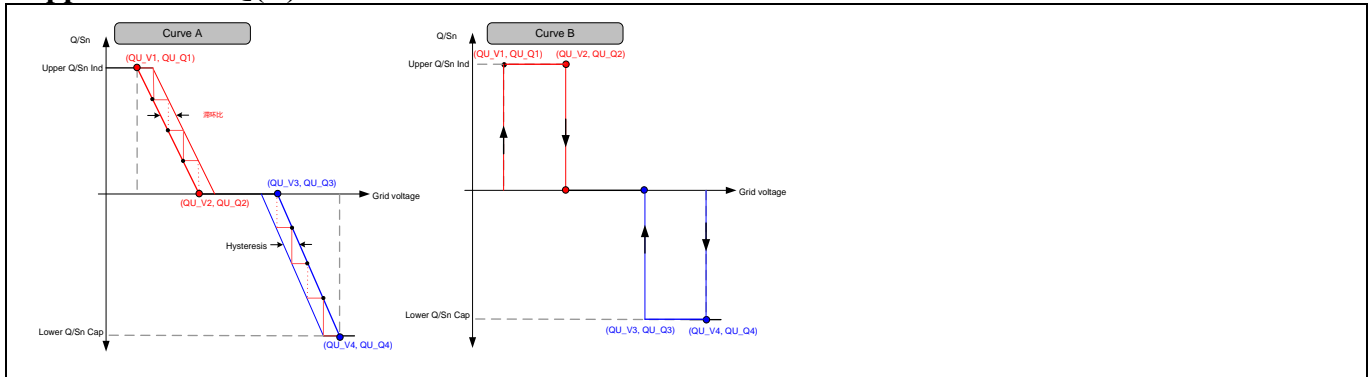

Q(U) Curve	5135	U16	0-1 0: Curve A; 1: Curve B		
Hysteresis Ratio	5136	U16	0~50	0.1%	
QU_V1	5137	U16	800~ 1000	0.1%	
QU_Q1	5138	U16	If support Overload -660-0 If not -600-0	0.1%	
QU_V2	5139	U16	800~1000	0.1%	
QU_Q2	5140	U16	If support Overload -660-660 If not -600-600	0.1%	
QU_V3	5141	U16	1000~1200	0.1%	
QU_Q3	5142	U16	If support Overload -660-660 If not -600-600	0.1%	
QU_V4	5143	U16	1000~1200	0.1%	
QU_Q4	5144	U16	If support Overload 0-660 If not 0-600	0.1%	
QU_EnterPower	5145	U16	200-1000	0.1%	
QU_ExitPower	5146	U16	10-200	0.1%	
QU_EnableMode	5147	U16	0xAA Yes 0x55 No		
QU_LimitPFValue	5148	U16	0-95	0.01	
Reserved	5149~5154				

QU_V1ve B; Inioiooower
QU_EnableMode:
Enter and exit Q (U) mode conditions,
0xAA, unconditional entry and exit;
0x55, conditional entry and exit:
the current power is higher than
QU_EnterPower,
and the current power is lower than
QU_ExitPower.
0x5A, conditional entry
PF is lower than
QU_LimitPFValue

① Except SG0.7/1.0/1/5/2.0/2.5/3.0RS-S, SG3.0/3.6/4.0/5.0/6.0RS, SG5.0RS-ADA, SG8.0/9.0/10RS

8. Examples

Take ComTest for example.

a) Acquire one piece of running information

Supposed that the inverter address is 1, it needs to acquire data from address 5000 of 3x address type.

The PC sends (HEX):

01 04 13 87 00 01 85 67

The inverter replies (HEX):

01 04 02 01 32 39 75

Note: The type code of inverter SG60KU-M is 0x0132.

b) Acquire multiple running information

Supposed that the inverter address is 1, it needs to acquire 10 data from address starting from 5000 of 3x address type

The PC sends (HEX):

01 04 13 87 00 0A C4 A0

The inverter replies (HEX):

01 04 14 01 32 00 28 00 00 00 00 00 05 00 00 00 26 00 00 00 00 00 56 EA

Note: The type code of inverter SG60KU-M is 0x0132. The nominal output power is 4.0kW, two-phase. Daily power generation is 0. The total power generation is 5kWh. The total running time is 38h. The internal temperature is 0°C. The internal transformer temperature is 0°C.

c) Acquire SN

Supposed that the inverter address is 1, it needs to acquire 10 data from address starting from 4990 of 3x address type

The PC sends (HEX):

01 04 13 7D 00 0A E4 91

The inverter replies (HEX):

01 04 14 31 32 31 32 31 32 30 30 31 00 00 00 00 00 00 00 00 00 00 9B 56

Note:

1. SN data type is UTF-8;
2. Serial number is: 121212001

d) Read one setting datum

Supposed that the inverter address is 1, it needs to read data from address 5000 of 4x address type.

The PC sends (HEX):

01 03 13 87 00 01 30 A7

The inverter replies (HEX):

01 03 02 07 D8 BA 2E

Note: the data read out is year 2008.

e) Read multiple setting data

Supposed that the inverter address is 1, it needs to read 10 data from address starting from 5000 of 4x address type.

The PC sends (HEX):

01 03 13 87 00 0A 71 60

The inverter replies (HEX):

01 03 14 07 DA 00 0A 00 1E 00 09 00 28 00 25 00 CE 00 AA 01 F4 00 00 80 53

Note: The data are October, 10, 2010, 09:40:37; Stop; power limitation on, power limitation value is 50 %.

f) Set one datum

Supposed that the inverter address is 1, it needs to set data from address 5000 of 4x address type.

The PC sends (HEX):

01 10 13 87 00 01 02 07 DA 19 4D

The inverter replies (HEX):

01 10 13 87 00 01 B5 64

Or

The PC sends (HEX):

01 06 13 87 07 DA BE CC

The inverter replies (HEX):

01 06 13 87 07 DA BE CC

Note: The setting data is year 2010

g) Set multiple data

Supposed that the inverter address is 1, it needs to set 10 data to address starting from 5000 of 4x address type.

The PC sends (HEX):

01 10 13 87 00 0A 14 07 D9 00 0A 00 1E 00 09 00 10 00 00 00 CE 00 AA 01 F4 00 00 3E 65

The inverter replies (HEX):

01 10 13 87 00 0A F4 A3

Note: The data are October, 30, 2009, 09:16:00, stop, power limitation on, power limitation value is 50 %.

h) Read device running information

Supposed that the inverter address is 1, it needs to set 8 data to address starting from 5038 of 3x address type.

The PC sends (HEX):

01 04 13 AD 00 0864 A9

The inverter replies (HEX):

01 04 10 55 00 07 DF 00 0C 00 15 00 04 00 0C 00 3B 00 0A EE D1

Note:

1) Device running state is Fault(0x5500); the fault/alarm time and code are valid in this state;

2) Fault time: 4 (0x0004):12(0x000C): 59(0x003B), Dec. (0x000C), 21(0x0015), 2015(0x07DF); the fault is island (0x000A).