

# C440/XTOE Electronic Overload Relay, Modbus

## User Manual

Effective March 2011  
New Information



**EATON**

*Powering Business Worldwide*



## **Disclaimer of Warranties and Limitation of Liability**

The information, recommendations, descriptions, and safety notations in this document are based on Eaton Electrical Inc. and/or Eaton Corporation's ("Eaton") experience and judgment, and may not cover all contingencies. If further information is required, an Eaton sales office should be consulted.

Sale of the product shown in this literature is subject to the terms and conditions outlined in appropriate Eaton selling policies or other contractual agreement between Eaton and the purchaser.

THERE ARE NO UNDERSTANDINGS, AGREEMENTS, WARRANTIES, EXPRESSED OR IMPLIED, INCLUDING WARRANTIES OF FITNESS FOR A PARTICULAR PURPOSE OR MERCHANTABILITY, OTHER THAN THOSE SPECIFICALLY SET OUT IN ANY EXISTING CONTRACT BETWEEN THE PARTIES. ANY SUCH CONTRACT STATES THE ENTIRE OBLIGATION OF EATON. THE CONTENTS OF THIS DOCUMENT SHALL NOT BECOME PART OF OR MODIFY ANY CONTRACT BETWEEN THE PARTIES. In no event will Eaton be responsible to the purchaser or user in contract, in tort (including negligence), strict liability or otherwise for any special, indirect, incidental, or consequential damage or loss whatsoever, including but not limited to damage or loss of use of equipment, plant or power system, cost of capital, loss of power, additional expenses in the use of existing power facilities, or claims against the purchaser or user by its customers resulting from the use of the information, recommendations, and descriptions contained herein.

The information contained in this manual is subject to change without notice.

Cover Photo: C440/XTOE Electronic Overload Relay, Modbus

## Support Services

The goal of Eaton is to ensure your greatest possible satisfaction with the operation of our products. We are dedicated to providing fast, friendly, and accurate assistance. That is why we offer you so many ways to get the support you need. Whether it's by phone, fax, or e-mail, you can access Eaton's support information 24 hours a day, seven days a week. Our wide range of services is listed below.

You should contact your local distributor for product pricing, availability, ordering, expediting, and repairs.

### Web Site

Use the Eaton Web site to find product information. You can also find information on local distributors or Eaton's sales offices.

### Web Site Address

[www.eaton.com/electrical](http://www.eaton.com/electrical)

### EatonCare Customer Support Center

Call the EatonCare Support Center if you need assistance with placing an order, stock availability or proof of shipment, expediting an existing order, emergency shipments, product price information, returns other than warranty returns, and information on local distributors or sales offices.

Voice: 877-ETN-CARE (386-2273) (8:00 a.m.–6:00 p.m. EST)

FAX: 800-752-8602

After-Hours Emergency: 800-543-7038  
(6:00 p.m.–8:00 a.m. EST)

If you are in the U.S. or Canada, and have OI or PLC questions, you can take advantage of our toll-free line for technical assistance with hardware and software product selection, system design and installation, and system debugging and diagnostics. Technical support engineers are available for calls during regular business hours.

### Technical Resource Center

Voice: 877-ETN-CARE (386-2273) (8:00 a.m.–5:00 p.m. EST)

FAX: 828-651-0549

e-mail: [TRC@Eaton.com](mailto:TRC@Eaton.com)

### European PanelMate Support Center

This engineering company, located in Zurich, Switzerland, provides high-level quality support and repair assistance for your PanelMate products. You will receive technical and application support.

### For Customers in Europe, contact:

BFA Solutions, Ltd.

Voice: +41 1 806.64.44 (9:00 a.m.–5:00 p.m. CET)

e-mail: [gk@bfa.ch](mailto:gk@bfa.ch)

[www.bfa.ch](http://www.bfa.ch)

### Repair and Upgrade Service

Additional support is also available from our well-equipped Repair and Upgrade Service department. If you have questions regarding the repair or upgrade of an OI product, contact your local distributor.

### Repair and Upgrade Service (support for OI)

Voice:

877-ETN-CARE (877-386-2273) (8:00 a.m.–5:00 p.m. EST)

414-449-7100 (8:00 a.m.–5:00 p.m. EST)

FAX: 614-882-3414

e-mail: [TRC@eaton.com](mailto:TRC@eaton.com)

## Table of Contents

### SAFETY

Definitions and Symbols . . . . .	vi
Hazardous High Voltage . . . . .	vi
Warnings and Cautions . . . . .	vi

### INTRODUCTION

System Overview . . . . .	1
Features and Benefits . . . . .	1
Standards and Certifications . . . . .	2

### TECHNICAL DATA AND SPECIFICATIONS

Electronic Overload Relay Ratings . . . . .	4
Short Circuit Ratings . . . . .	7

### RECEIPT/UNPACKING

General . . . . .	9
Unpacking . . . . .	9
Storage . . . . .	9
Communication and Mounting . . . . .	9

### C440-COM-ADP COMMUNICATION MODULE

Input Behavior . . . . .	11
Modbus Settings . . . . .	12
Wiring Configuration . . . . .	12
Modbus Registers . . . . .	13
Modbus Addressing . . . . .	17
Modbus Baud Rate and Parity . . . . .	17
0x2B/0x0E Read Device Identification Get Device Identity (43/14) Details . . . .	17
Modbus Command Register (400) . . . . .	17
Configuration Reset Register (402) . . . . .	17
Range Checking . . . . .	17
Comm Loss Timeout (Reg 440) . . . . .	18
Comm Loss Behavior (Reg 441) . . . . .	18

**List of Figures**

Expansion Module Wiring. . . . . **9**  
C441x Communication Module . . . . . **10**  
C440-COM-ADP . . . . . **10**  
C440 to C440-COM-ADP Wiring . . . . . **10**  
Modbus Wiring Configuration. . . . . **12**

## List of Tables

Electronic Overload Education . . . . .	<b>3</b>
Electronic Overload Relays Up to 1500A—Ratings and Specifications . . . . .	<b>4</b>
C440/ <b>XT</b> Standalone Overload Relays ( <b>XT</b> , C440) . . . . .	<b>7</b>
NEMA Freedom Series Starters with C440 Electronic Overload Relays . . . . .	<b>8</b>
IEC <b>XT</b> Starters with <b>XT</b> Electronic Overload Relays . . . . .	<b>8</b>
Field Terminal Wire Capability . . . . .	<b>11</b>
Modbus Parameters . . . . .	<b>11</b>
Modbus Settings. . . . .	<b>12</b>
Wiring Configuration . . . . .	<b>12</b>
Modbus Registers. . . . .	<b>13</b>
Additional Modbus Registers . . . . .	<b>15</b>
Command Codes . . . . .	<b>17</b>
Reset Codes . . . . .	<b>17</b>
Comm Loss Behavior . . . . .	<b>18</b>

## Safety

### Definitions and Symbols

---

 **WARNING**

---

This symbol indicates high voltage. It calls your attention to items or operations that could be dangerous to you and other persons operating this equipment. Read the message and follow the instructions carefully.

---



This symbol is the “Safety Alert Symbol.” It occurs with either of two signal words: CAUTION or WARNING, as described below.

---

---

 **WARNING**

---

Indicates a potentially hazardous situation which, if not avoided, can result in serious injury or death.

---

---

 **CAUTION**

---

Indicates a potentially hazardous situation which, if not avoided, can result in minor to moderate injury, or serious damage to the product. The situation described in the CAUTION may, if not avoided, lead to serious results. Important safety measures are described in CAUTION (as well as WARNING).

---

### Hazardous High Voltage

---

 **WARNING**

---

Motor control equipment and electronic controllers are connected to hazardous line voltages. When servicing drives and electronic controllers, there may be exposed components with housings or protrusions at or above line potential. Extreme care should be taken to protect against shock.

Stand on an insulating pad and make it a habit to use only one hand when checking components. Always work with another person in case an emergency occurs. Disconnect power before checking controllers or performing maintenance. Be sure equipment is properly grounded. Wear safety glasses whenever working on electronic controllers or rotating machinery.

### Warnings and Cautions

---

 **WARNING**

---

Do not service with voltage applied—Lock-out Tags.



## Introduction

### System Overview

Eaton's new electronic overload relay (EOL) is the most compact, high-featured, economical product in its class. Designed on a global platform, the new EOL covers the entire power control spectrum including NEMA®, IEC, and DP contactors. The NEMA and DP versions are offered with the C440 designation while the IEC offering has the **XT** designation. The electronic design provides reliable, accurate and value driven protection and communications capabilities in a single compact device. It is the flexible choice for any application requiring easy-to-use, reliable protection.

Eaton has a long history of innovations and product development in motor control and protection, including both traditional NEMA, as well as IEC control. It was from this experience that the C440 was developed, delivering new solutions to meet today's demands.

C440 is a self-powered electronic overload relay available up to 100A as a self contained unit. With external CTs, C440 can protect motor up to 1500 FLA. Available add-on accessories include remote reset capability and communication modules with I/O for DeviceNet™, PROFIBUS®, and Modbus®.

### Features and Benefits

#### Features

- Reliable, accurate, electronic motor protection
- Easy to select, install and maintain
- Compact size
- Flexible, intelligent design
- Global product offering—available with NEMA, IEC, and DP power control

#### Size/Range

- Broad FLA range (0.33–1500A)
- Selectable trip class (10A, 10, 20, 30)
- Direct mounting to NEMA, IEC, and DP contactors
- Most compact electronic overload in its class

### Motor Control

- Two B600 alarm (NO) and fault (NC) contacts
- Test/Trip button

### Motor Protection

- Thermal overload
- Phase loss
- Selectable (ON/OFF) phase unbalance
- Selectable (ON/OFF) ground fault

### User Interface

- Large FLA selection dial
- Trip status indicator
- Operating mode LED
- DIP switch selectable trip class, phase unbalance, and ground fault
- Selectable Auto/Manual reset

### Feature Options

- Remote reset
  - 120 Vac
  - 24 Vac
  - 24 Vdc
- Tamper-proof cover
- Communications modules
  - Modbus RTU RS-485
  - DeviceNet with I/O
  - PROFIBUS with I/O
  - Modbus RTU with I/O (Q4 2010)
  - Ethernet IP (planned)

# Introduction

## Benefits

### Reliability and Improved Uptime

- C440 provides the users with peace of mind knowing that their assets are protected with the highest level of motor protection and communication capability in its class
- Extends the life of plant assets with selectable motor protection features such as trip class, phase unbalance, and ground fault
- Protects against unnecessary downtime by discovering changes in your system (line/load) with remote monitoring capabilities
- Status LED provides added assurance that valuable assets are protected by indicating the overload operational status

### Flexibility

- Available with NEMA, IEC and DP contactors
- Improves return on investment by reducing inventory carrying costs with wide FLA adjustment (5:1) and selectable trip class
- Design incorporates built-in ground fault protection thus eliminating the need for separate CTs and modules
- Flexible communication with optional I/O enables easy integration into plant management systems for remote monitoring and control
- Available as an open component and in enclosed control and motor control center assemblies

### Monitoring Capabilities

- Individual phase currents rms
- Average three-phase current rms
- Thermal memory
- Fault indication (overload, phase loss, phase unbalance, ground fault)

### Safety

- IP 20 rated terminal blocks
- Available in Eaton's industry leading FlashGard MCCs
- Tested to the highest industry standards such as UL, CSA, CE, and IEC
- RoHS compliant

## Standards and Certifications

- UL®
- CSA®
- CE
- NEMA
- IEC/EN 60947 VDE 0660
- ISO® 13849-1 (EN954-1)
- RoHS
- ATEX directive 94/9/EC
- Equipment Group 2, Category 2



**Electronic Overload Education**

<b>Description</b>	<b>Definition</b>	<b>Cause</b>	<b>Effect if Not Protected</b>	<b>C440/XT Protection</b>
<b>Motor Protection</b>				
Thermal overload	Overload is a condition in which current draw exceeds 115% of the full load amperage rating for an inductive motor.	<ul style="list-style-type: none"> <li>• An increase in the load or torque that is being driven by the motor</li> <li>• A low voltage supply to the motor causes the current to go high to maintain the power needed</li> <li>• A poor power factor causing above normal current draw</li> </ul>	<ul style="list-style-type: none"> <li>• Increase in current draw leads to heat and insulation breakdown, which can cause system failure</li> <li>• Increase in current can increase power consumption and waste valuable energy</li> </ul>	<ul style="list-style-type: none"> <li>• Thermal trip behavior is defined by UL, CSA, and IEC standards</li> <li>• Trip class is settable from 10A, 10, 20, 30</li> </ul>
Ground fault	A line to ground fault.	A current leakage path to ground.	An undetected ground fault can burn through multiple insulation windings, ultimately leading to motor failure, not to mention risk to equipment or personnel	Fixed protective setting that takes the starter offline if ground fault current exceeds 50% of the FLA dial setting, for example, if the FLA dial is set to 12A, the overload relay will trip if the ground current exceeds 6A.
Unbalanced phases (voltage and current)	Uneven voltage or current between phases in a three-phase system.	When a three-phase load is powered with a poor quality line, the voltage per phase may be unbalanced.	Unbalanced voltage causes large unbalanced currents and as a result this can lead to motor stator windings being overloaded, causing excessive heating, reduced motor efficiency and reduced insulation life.	Fixed protective setting that takes the starter offline if a phase drops below 50% of the other two phases.
Phase loss—current (single-phasing)	One of the three-phase voltages is not present.	Multiple causes, loose wire, improper wiring, grounded phase, open fuse, and so on.	Single-phasing can lead to unwanted motor vibrations in addition to the results of unbalanced phases as listed above.	Fixed protective setting that takes the starter offline if a phase drops below 50% of the other two phases.

## Technical Data and Specifications

### Electronic Overload Relay Ratings

#### Electronic Overload Relays Up to 1500A—Ratings and Specifications

Description	Specification	
	45 mm	55 mm
<b>Electrical Ratings</b>	<b>Range</b>	<b>Range</b>
Operating voltage (three-phase) and frequency	690 Vac (60/50 Hz)	690 Vac (60/50 Hz)
<b>FLA Range</b>		
	0.33–1.65A; 1–5A; 4–20A; 9–45A	20–100A
<b>Use with Contactors</b>		
<b>XT</b> IEC frames	B, C, D	F, G
Freedom NEMA sizes	00, 0, 1, 2	3
<b>Trip Class</b>		
	10A, 10, 20, 30; selectable	10A, 10, 20, 30; selectable
<b>Motor Protection</b>		
Thermal overload setting	1.05 x FLA: does not trip 1.15 x FLA: overload trip	1.05 x FLA: does not trip 1.15 x FLA: overload trip
<b>Feature</b>	<b>Range</b>	<b>Range</b>
Phase loss	Fixed threshold 50%	Fixed threshold 50%
Phase unbalance (selectable: enable/disable)	Fixed threshold 50%	Fixed threshold 50%
Ground fault (selectable: enable/disable)	50% of FLA dial setting >150% = 2 sec >250% = 1 sec	50% of FLA dial setting >150% = 2 sec >250% = 1 sec
Reset	Manual/automatic	Manual/automatic
<b>Indicators</b>		
Trip status	Orange flag	Orange flag
Mode LED	One flash: Overload operating properly Two flashes: Current is above FLA dial setting— pending trip	One flash: Overload operating properly Two flashes: Current is above FLA dial setting— pending trip
<b>Options</b>		
Remote reset	Yes	Yes
Reset bar	Yes	Yes
Communication expansion module	Yes	Yes
Communication adapter	Yes	Yes
<b>Capacity</b>		
Load terminals		
Terminal capacity	12–10 AWG (4–6 mm <sup>2</sup> ) 8–6 AWG (6–16 mm <sup>2</sup> )	6–1 AWG (16–50 mm <sup>2</sup> )
Tightening torque	20–25 lb-in (2.3–2.8 Nm) 25–30 lb-in (2.8–3.4 Nm)	25–30 lb-in (2.8–3.4 Nm)
Input, auxiliary contact and remote reset terminals		
Terminal capacity	2 x (18–12) AWG	2 x (18–12) AWG
Tightening torque	5.3 lb-in (0.8–1.2 Nm)	5.3 lb-in (0.8–1.2 Nm)

**Electronic Overload Relays Up to 1500A—Ratings and Specifications, continued**

Description	Specification	
	45 mm	55 mm
<b>Voltages</b>		
Insulation voltage $U_i$ (three-phase)	690 Vac	690 Vac
Insulation voltage $U_i$ (control)	500 Vac	500 Vac
Rated impulse withstand voltage	6000 Vac	6000 Vac
Overvoltage category/pollution degree	III/3	III/3
<b>Auxiliary and Control Circuit Ratings</b>		
Conventional thermal continuous current	5A	5A
Rated operational current—IEC AC-15		
Make contact (1800 VA)		
120V	15A	15A
240V	15A	15A
415V	0.5A	0.5A
500V	0.5A	0.5A
Break contact (180 VA)		
120V	1.5A	1.5A
240V	1.5A	1.5A
415V	0.9A	0.9A
500V	0.8A	0.8A
IEC DC-13 (L/R F 15 ms1)		
0–250V	1.0A	1.0A
Rated operational current—UL B600		
Make contact (3600 VA)		
120V	30A	30A
240V	15A	15A
480V	7.5A	7.5A
600V	6A	6A
Break contact (360 VA)		
120V	3A	3A
240V	1.5A	1.5A
480V	0.75A	0.75A
600V	0.6A	0.6A
R300— Vdc ratings (28 VA)		
0–120V	0.22A	0.22A
250V	0.11A	0.11A

# Technical Data and Specifications

## Electronic Overload Relays Up to 1500A—Ratings and Specifications, continued

Description	Specification	
	45 mm	55 mm
<b>Short-Circuit Rating without Welding</b>		
Maximum fuse	6A gG/gL	6A gG/gL
<b>Environmental Ratings</b>		
Ambient temperature (operating)	−13° to 149°F (−25° to 65°C)	−13° to 149°F (−25° to 65°C)
Ambient temperature (storage)	−40° to 185°F (−40° to 85°C)	−40° to 185°F (−40° to 85°C)
Operating humidity UL 991 (H3)	5% to 95% non-condensing	5% to 95% non-condensing
Altitude (no derating) NEMA ICS1	2000m	2000m
Shock (IEC 60068-2-27)	15g any direction	15g any direction
Vibration (IEC 60068-2-6)	3g any direction	3g any direction
Pollution degree per IEC 60947-4-1	3 for product (2 for pcb)	3 for product (2 for pcb)
Ingress protection	IP20	IP20
Protection against direct contact when actuated from front (IEC 536)	Finger- and back-of-hand proof	Finger- and back-of-hand proof
Mounting position	Any	Any
Climatic proofing	Damp heat, constant to IEC 60068-2-30	Damp heat, constant to IEC 60068-2-30
<b>Electrical/EMC</b>		
Radiated emissions IEC 60947-4-1-Table 15 EN 55011 (CISPR 11) Group 1, Class A, ISM	30 MHz to 1000 MHz	30 MHz to 1000 MHz
Conducted emissions IEC 60947-4-1-Table 14 EN 55011 (CISPR 11) Group 1; Class ISM	0.15 MHz to 30 MHz	0.15 MHz to 30 MHz
ESD immunity IEC 60947-4-1 (Table 13)	±8 kV air, ±6 kV contact	±8 kV air, ±6 kV contact
Radiated immunity IEC 60947-4-1 IEC 61000-4-3	10V/m 80 MHz–1000 MHz 3V/m from 1.4 to 2.7 GHz 80% amplitude modulated 1 kHz sine wave	10V/m 80 MHz–1000 MHz 3V/m from 1.4 to 2.7 GHz 80% amplitude modulated 1 kHz sine wave
Conducted immunity IEC 60947-4-1, IEC 61000-4-6	140 dub (10V rms) 150 kHz–100 MHz	140 dub (10V rms) 150 kHz–100 MHz
Fast transient immunity IEC 60947-4-1 (Table 13) IEC 61000-4-4	±4 kV using direct method with accessory installed in expansion bay ±2 kV using direct method	±4 kV using direct method with accessory installed in expansion bay ±2 kV using direct method

**Electronic Overload Relays Up to 1500A—Ratings and Specifications, continued**

Description	Specification	
	45 mm	55 mm
<b>Electrical/EMC, continued</b>		
Surge immunity IEC 60947-4-1 (Table 13) IEC 61000-4-5 a Class 4	Three-phase power inputs: ±4 kV line-to-line (DM) ±4 kV line-to-ground (CM)  With accessory installed in expansion bay: ±2 kV line-to-line (DM) →1.2/50 us; 2 kV line-to-earth, 1 kV line-to-line ±4 kV line-to-ground (CM)	Three-phase power inputs: ±4 kV line-to-line (DM) ±4 kV line-to-ground (CM)  With accessory installed in expansion bay: ±2 kV line-to-line (DM) →1.2/50 us; 2 kV line-to-earth, 1 kV line-to-line ±4 kV line-to-ground (CM)
Power freq. magnetic field immunity IEC 60947-4-1, IEC 61000-4-8	30A/m, 50 Hz	30A/m, 50 Hz
Electromagnetic field IEC 60947-4-1 Table 13, IEC 61000-4-3	10V/m	10V/m
Distortion IEEE 519	5% THD max., 5th harmonic 3% max.	5% THD max., 5th harmonic 3% max.
Electrostatic discharge (ESD) IEC 61000-4-2, EN 61131-2	4 kV contact 8 kV air discharge	4 kV contact 8 kV air discharge
Electrical fast transient (EFT) IEC 61000-4-4, EN 61131-2	±2 kV using direct method	±2 kV using direct method
Surge immunity IEC 61000-4-5, EN 61131-2	±2 kV line-to-ground (CM)	±2 kV line-to-ground (CM)

**Short Circuit Ratings**
**Short Circuit Ratings (North America CSA, cUL)**

Changes to UL 508A and NEC in recent years have brought a focus to control panel safety with regard to short-circuit current ratings (SCCR). Eaton's C440 electronic overload relays combined with **XT** series IEC and Freedom Series NEMA contactors provide a wide variety of SCCR solutions needed for a variety of applications. The SCCR data in this document reflects the latest information as of April 2010.

**C440/XT Standalone Overload Relays (XT, C440)**

Overload FLA Range	Maximum Operating Voltage	Standard-Fault Short Circuit Data			High-Fault Short Circuit Data			Thermal-Magnetic Circuit Breakers		
		600V (kA)	Maximum Fuse Size (A) (RK5)	Maximum Breaker Size (A)	Fuses (RK5, J, CC)			480V (kA)	600V (kA)	Maximum Breaker Size
					480V (kA)	600V (kA)	Maximum Fuse Size			
0.33–1.65A	600 Vac	1	6	15	—	—	—	—	—	—
1–5A	600 Vac	5	20	20	100	100	30	100	35	20
4–20A	600 Vac	5	80	80	100	100	100	100	35	80
9–45A	600 Vac	5	175	175	100	100	100	100	35	100/175 (480/600)
20–100A	600 Vac	10	400	400	100	100	200	150	35	250/400 (480/600)

# Technical Data and Specifications

## NEMA Freedom Series Starters with C440 Electronic Overload Relays

NEMA Size	Maximum Operating Voltage	High-Fault Short Circuit Data			Thermal-Magnetic Circuit Breakers		
		Fuse (RK5, J, CC) 480V	600V	Maximum Fuse Size	480V	600V	Maximum Breaker Size
00	0.33–1.65A	100	100	30	—	—	—
	1–5A	100	100	30	100	35	35
	4–20A	100	100	30	100	35	35
0	0.33–1.65A	100	100	60	—	—	—
	1–5A	100	100	60	100	35	70
	4–20A	100	100	60	100	35	70
1	0.33–1.65A	100	100	100	—	—	—
	1–5A	100	100	100	100	35	100
	4–20A	100	100	100	100	35	100
	9–45A	100	100	100	100	35	100
2	1–5A	100	100	100	100	35	175
	4–20A	100	100	100	100	35	175
	9–45A	100	100	100	100	35	175
3	20–100A	100	100	200	50	50	250

## IEC XT Starters with XT Electronic Overload Relays

NEMA Size	Maximum Operating Voltage	High-Fault Short Circuit Data			Thermal-Magnetic Circuit Breakers		
		Fuse (RK5, J, CC) 480V	600V	Maximum Fuse Size	480V	600V	Maximum Breaker Size
B	1–5A	100	100	30	—	—	—
	4–20A	100	100	30	—	—	—
C	1–5A	100	100	60	—	—	—
	4–20A	100	100	60	—	—	—
	9–45A	100	100	60	—	—	—
D	9–45A	100	100	200	65	35	175
	20–100A	100	100	200	65	35	175
F	20–100A	100	100	200	65	65	350
G	20–100A	100	100	200	65	65	350



## Receipt/Unpacking

### WARNING

**Do not service with voltage applied—Lock-out Tags.**

#### General

Upon receipt of the unit, verify that the catalog number and unit options stated on the shipping container match those stated on the order/purchase form.

Inspect the equipment upon delivery. Report any crate or carton damage to the carrier prior to accepting the delivery. Have this information noted on the freight bill. Eaton is not responsible for damage incurred in shipping.

#### Unpacking

Remove all packing material from the unit. Check the unit for any signs of shipping damage. If damage is found after unpacking, report it to the freight company. Retain the packaging materials for carrier to review.

Verify that the unit's catalog number and options match those stated on the order/purchase form.

#### Storage

It is recommended that the unit be stored in its original shipping box/crate until it is to be installed.

The unit should be stored in a location where:

- The ambient temperature is  $-40^{\circ}$  to  $85^{\circ}\text{C}$
- The relative humidity is 5–95%, non-condensing
- The environment is dry, clean and non-corrosive
- The unit will not be subjected to high shock or vibration conditions

#### Communication and Mounting

C440/XTOE electronic overload offers two levels of communication capability over Modbus.

1. Monitoring only.
2. Monitoring and control.

#### Monitoring ONLY

For the monitoring only option, the expansion module (C440-XCOM) needs to be wired to the C440/XTOE electronic overload relay as shown in the following figure.

#### Expansion Module Wiring

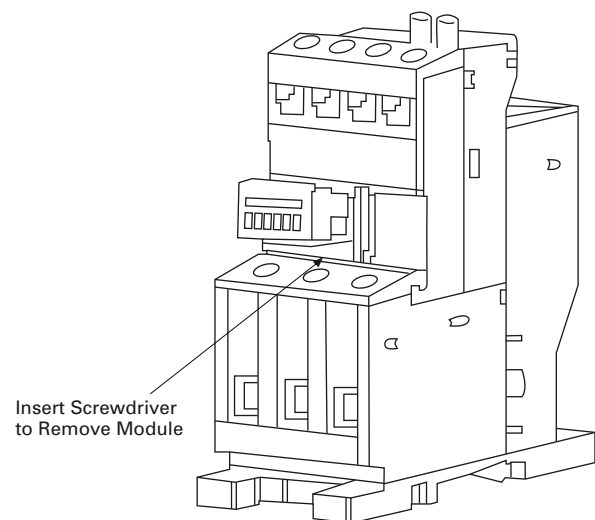
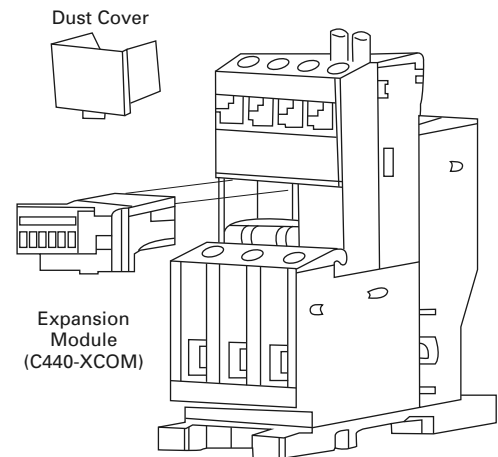

1. Remove dust cover.
2. Insert C440-XCOM module until detent is reached.
3. Pull terminal block from module.
4. Assure module was retained by overload.
5. Wire per **Page 10**, C440 to C440-COM-ADP Wiring.

#### Monitoring and Control

The monitoring and control option requires the use of a communication adapter (C440-COM-ADP), expansion module and Modbus communication module (C441N or C441P).

## C440-COM-ADP Communication Module

### C440-COM-ADP Communication Module

The Modbus communication modules are designed to be installed on the right side of the communication adapter (C440-COM-ADP).

1. Align module with side of the communication adapter (C440-COM-ADP).
2. Slide module bottom pegs into appropriate slots.
3. Rotate module up and gently click the base unit and module together.
4. Connect the appropriate network cable and IO connector if desired.

### C441x Communication Module

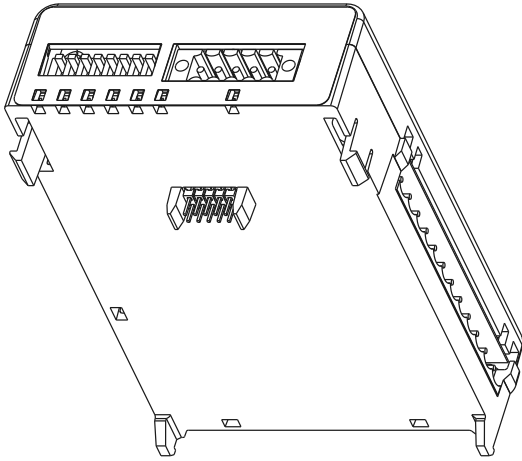

### C440-COM-ADP

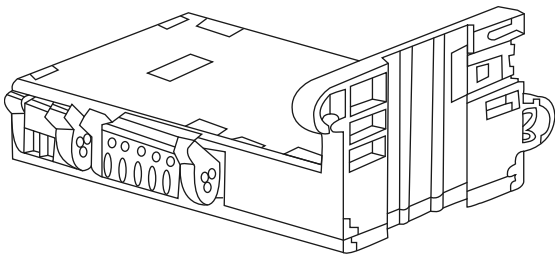

### C440 to C440-COM-ADP Wiring

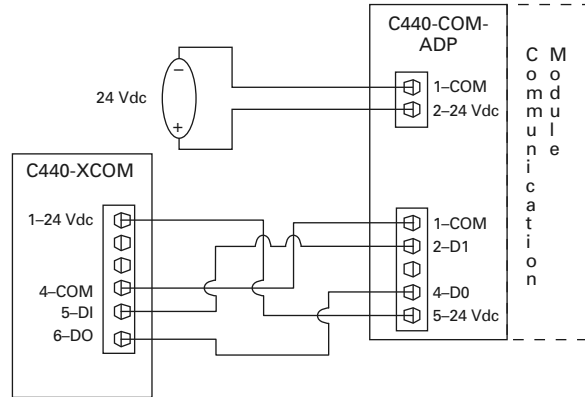

## Input Behavior

Each terminal of the field connection accepts two wires of the following size:

### Field Terminal Wire Capability

Wire Type	Wire Size	Terminal Torque (in-lbs)
Solid Cu-90C	#14-#22	4.5
Stranded Cu-90C	#16-#22	4.5

## Quick Start

The following parameters configure the Modbus communication interface. Parameters may be set through the Modbus port.

### Modbus Parameters

Modbus Parameter	UI Interface	Modbus Register	Default	Notes
Modbus address	Operation param	431	1	Must be unique and between 1 and 247.
Modbus baud rate	Advanced param P.00	432	19.2k	Requires power cycle reset to take effect.
Modbus parity	Advanced param P.01	442	8,e,1	8 data bits, even parity, 1 stop bit. Requires power cycle reset to take effect.
Common loss behavior	Advanced param P.04	441	1	Default is 1, for fault on common loss.
Common loss timeout	—	440	2000	2 seconds.
Configuration reset	Advanced param P.05	402	0, no reset asserted	Set to 1 to give power cycle reset (soft reset). Clears after reset. asserted.

**Note:** To enable comm. loss behavior, write 0X0088 to register 400.

## Modbus Settings

### Modbus Settings

Parameter	Value
Mode	Slave mode only
Modbus address/slave address	Network settable, default = 1 (0 = for broadcast)
Baud rate	19.2kb
Byte characteristics	8-bit, even parity, 1-stop bit
Commands supported	0x03–Read holding registers 0x04–Read input registers 0x06–Write single register 0x10–Write multiple holding registers 0x2B/0x0E–Read device identification
Protocol supported	Modbus RTU
Electrical signaling	RS-485 (ANSI/TIA/EIA-485), two-wire
Checksum	CRC16bit 0x8005 (or CRC-CCITT 0x1021)
Maximum number of devices	32 (1 unit load per RS-485) Note: line polarization will reduce maximum # of devices by 4
Maximum cable length	Dependent on baud rate, cable characteristics, number of loads. Reference Modbus-IDA over serial line specification and implementation guide and EIA-485 for details

## Wiring Configuration

Modbus expansion wiring interface.

### Wiring Configuration

Pin #	Description
1	24 Vdc power supply connection
2	Remote reset dry contact source. This is a 24 Vdc signal to be applied to a dry contact (for example, pushbutton).
3	Remote reset dry contact input
4	Common or ground power supply connection
5, 6	RS485 AB lines

### Modbus Wiring Configuration

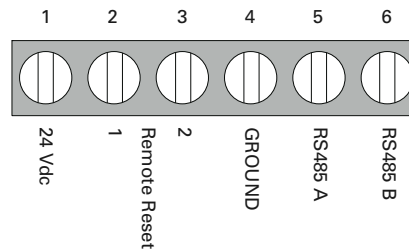

**Note:** All 32 bit values are Low word first. For example: 0xLLLL (register 1), 0xHHHH (register 2).

**Note:** Scaled current values are scaled using the “Current Reported Multiplier” register.

## Modbus Registers

### Modbus Registers

Modbus Register	Read/Write	Description	Details																						
300	R	Present overload state (tripped, running)	Motor control states: 0 = Stopped 1 = Running 2 = Tripped																						
301	R	Current in phase A (rms scaled)	Scaled rms current phase A																						
302	R	Current in phase B (rms scaled)	Scaled rms current phase B																						
303	R	Current in phase C (rms scaled)	Scaled rms current phase C																						
304	R	Average of three-phase currents (scaled)	Average of the 3 scaled rms currents																						
305	R	Thermal capacity in percent	Present thermal capacity. 100% equates to a trip condition.																						
306	R	Present fault bits	Faults are cleared when the device is either reset by the network or detects current flowing. The fault bits are defined as follows: <table border="0"> <tr> <td>Bit</td> <td>Feature</td> </tr> <tr> <td>0</td> <td>Overload fault</td> </tr> <tr> <td>1</td> <td>Phase imbalance</td> </tr> <tr> <td>2</td> <td>Phase loss fault</td> </tr> <tr> <td>3</td> <td>Ground fault</td> </tr> <tr> <td>4</td> <td>Network trip command</td> </tr> <tr> <td>5</td> <td>NV memory failure</td> </tr> <tr> <td>6-&gt;</td> <td>Reserved</td> </tr> </table>	Bit	Feature	0	Overload fault	1	Phase imbalance	2	Phase loss fault	3	Ground fault	4	Network trip command	5	NV memory failure	6->	Reserved						
Bit	Feature																								
0	Overload fault																								
1	Phase imbalance																								
2	Phase loss fault																								
3	Ground fault																								
4	Network trip command																								
5	NV memory failure																								
6->	Reserved																								
307	R	Current as a percentage of FLA	Presents the average current as a percent of the FLA setting.																						
308	R	Phase imbalance percentage	Percent of measured phase imbalance																						
309	R	Ground fault percent (of 0.5 FLA)	Percent of ground fault measured. $GF\% = GFC / ([0.5] * FLA)$																						
310	R	Ground current (scaled)	Scaled ground current.																						
311	R	Overload FLA setting (scaled)	The present FLA setting. The potentiometer selects this value. The value is scaled by the multiplier.																						
312	R	Overload class setting	The present FLA class. Class settings are device dependent. When the device is externally powered, the class setting of 10A will read out and behave as a class 5 setting.																						
313	R	Line frequency	The line frequency measured by the device. The frequency is displayed in Hz.																						
314	R	Device feature states	The feature status bits are defined as follows: <table border="0"> <tr> <td>Bit</td> <td>Feature</td> </tr> <tr> <td>01</td> <td>Class index (00 = Class 10a; 01 = Class 10; 10 = Class 30; 11 = Class 20)</td> </tr> <tr> <td>2</td> <td>Phase loss/imbalance enabled</td> </tr> <tr> <td>3</td> <td>Ground fault enabled</td> </tr> <tr> <td>4</td> <td>Auto reset enabled</td> </tr> <tr> <td>5</td> <td>Remote reset active</td> </tr> <tr> <td>8</td> <td>DIP switch position 0</td> </tr> <tr> <td>9</td> <td>DIP switch position 1</td> </tr> <tr> <td>10</td> <td>DIP switch position 2</td> </tr> <tr> <td>11</td> <td>DIP switch position 3</td> </tr> <tr> <td>12-15</td> <td>Reserved</td> </tr> </table>	Bit	Feature	01	Class index (00 = Class 10a; 01 = Class 10; 10 = Class 30; 11 = Class 20)	2	Phase loss/imbalance enabled	3	Ground fault enabled	4	Auto reset enabled	5	Remote reset active	8	DIP switch position 0	9	DIP switch position 1	10	DIP switch position 2	11	DIP switch position 3	12-15	Reserved
Bit	Feature																								
01	Class index (00 = Class 10a; 01 = Class 10; 10 = Class 30; 11 = Class 20)																								
2	Phase loss/imbalance enabled																								
3	Ground fault enabled																								
4	Auto reset enabled																								
5	Remote reset active																								
8	DIP switch position 0																								
9	DIP switch position 1																								
10	DIP switch position 2																								
11	DIP switch position 3																								
12-15	Reserved																								
315	R	Device temperature in degrees C	The temperature as seen by the microcontroller. Accuracy ~ 10%.																						
316	R	Boost capacitor voltage (mV)	The voltage of the internal power supply cap—in milliVolts.																						

## C440-COM-ADP Communication Module

### Modbus Registers, continued

Modbus Register	Read/Write	Description	Details
317	R	Microcontroller Vcc voltage (mV)	The voltage of the microcontroller Vcc—in millivolts.
318	R	Expansion board ID value	The identifier associated with the attached expansion board.
332	RW	Command a trip or reset	When a state change is requested the bit will remain active until the device is able to execute the command. The bits are auto clearing after the state has been changed. Any other bits will simply be cleared. The following bits are defined: Bit   Action 0    Cause a trip (will override a reset). 1    Cause a reset
364	RW	Modbus address	The modbus address can be set over the network.
396	R	Minimum device FLA	This is the min FLA setting possible in this device. The value is scaled by the multiplier.
397	R	Maximum device FLA	This is the max FLA setting possible in this device. The value is scaled by the multiplier.
398	R	Current reported multiplier	This value indicates the scaling multiplier applied to the current values. For example: If the multiplier is 10 then all currents are scaled in deciamps; a register value of 12 is then 1.2A. To convert the read scaled current to amps divide the register value by the value in this location.
399	R	Product code	The C440 product code.
400	R	Serial number	32 bit vendor specific serial number.
402	R	Hardware revision	Hardware revision is stored as a 2 byte number with a major and minor revision.
428	R	Firmware revision	The firmware revision is represented as 0xMMmm. Where M = Major revision, m = minor revision.
429	R	Firmware build	The firmware build is a 16 bit number. 0xbbbb - b = build number.
430	R	Firmware checksum	The 32 bit checksum of the code.

### Additional Modbus Registers

The following Modbus data is provided in addition to the previously listed Modbus registers.

**Note:** The Modbus Register Address is -1 of the Modbus Register Number.

**Note:** All 32 bit values are Low word first LLLLHHHH. Example: Register 7 = Low word of serial number;  
Register 8 = High word of serial number.

### Additional Modbus Registers

Modbus Coil Number	Modbus Register Number	R/W	Parameter Name	Description
—	1	R	Field inputs	This is a bitfield of inputs. Bit 0 corresponds with input 1, bit 1 corresponds with input 2, etc.
1	—	—	—	Field input 1
2	—	—	—	Field input 2
3	—	—	—	Field input 3
4	—	—	—	Field input 4
—	2	R	Control voltage (24 Vdc)	The control voltage register is displayed in millivolts.
—	3	R	Ambient board temperature	Temperature is displayed in degrees celsius.
—	4	R	Maximum PC board temperature	The maximum ambient temperature seen by the PCB.
—	5	R	DIP switch value	Present value of the configuration DIP switch.
—	6	R	Configuration CRC	A CRC is calculated on the non-volatile configuration values. The CRC value is intended to provide a quick assessment of configuration state.
—	7	R	Communication module serial number	The serial number of the communication module.
—	9	R	Communication module firmware revision	Present firmware revision of the communication adapter.
—	11	R	Communication module hardware revision	Present hardware revision for the communication adapter PCB.
—	101	R/W	Field relay outputs	The relay output register is a bitfield. Bit 0 corresponds to relay out 1 and bit 1 corresponds to relay out 2.
1601	—	—	—	Field relay output 1

**Additional Modbus Registers, continued**

<b>Modbus Coil Number</b>	<b>Modbus Register Number</b>	<b>R/W</b>	<b>Parameter Name</b>	<b>Description</b>
1602	—	—	—	Field relay output 2
—	102	R/W	Field input 1 debounce time	The input debounce can be set for each input point. The debounce value is set in milliseconds. Minimum time is 1 ms. Maximum debounce time is 1000 ms
—	104	R/W	Field input 2 debounce time	
—	106	R/W	Field input 3 debounce time	
—	108	R/W	Field input 4 debounce time	
—	110	R/W	Modbus communication loss timeout value (ms)	Modbus communication loss timeout. The timeout can be set from 0 ms (disabled) to 65535 ms.
—	112	R/W	Remote modbus parity	0: Even parity, 1 stop bit 1: Odd parity, 1 stop bit 2: No parity, 2 stop bits 3: Even parity, 2 stop bits 4: Odd parity, 2 stop bits 5: No parity, 1 stop bit
—	222	R	Product code	0x1108 Modbus 24 Vdc standalone I/O 0x1109 Modbus 120 Vac standalone I/O 0x1113 C440 Modbus 24 Vdc I/O 0x1114 C440 Modbus 120 Vac I/O
—	1000	R/W	Modbus production list	The Production and consumption registers can be used to create custom Modbus interface ranges. Example: If field inputs register address 0 is put into the first slot of the production list, the field inputs register value will be available in the first slot of the Modbus production data register range. Production data is data provided by the device and consumption data is for data provided (written) to the device. Note that the values must be Modbus Register Address (i.e., Register Number–1) not Register Number.
—	2000	R	Modbus production data	
—	3000	R/W	Modbus consumption list	



## Modbus Addressing

The default Modbus slave address is 1. Care must be taken to ensure that there are not two devices with the same address. In such a case, an abnormal behavior of the whole serial bus can occur. The master may not be able to communicate with all present slaves on the bus. A change to the Modbus address will take effect immediately.

## Modbus Baud Rate and Parity

Baud rate and parity can be set through both the user interface and the Modbus port. The changes do not take effect until the next power cycle reset or soft reset, but they will be reported via their respective registers, or on the user interface. A soft reset can be requested by writing a 1 to the Configuration Reset Register 402.

For example, assume that the unit is configured to communicate at 19.2k. A read of register 432, Modbus Baud Rate Code, will return a "4" for 19.2k baud. If a subsequent write of "7" is made to register 432, to change the baud rate to 115.2k, the unit will return "7" when register 432 is read, but continue to communicate at 19.2k baud until either power cycle reset or soft reset is asserted. Once the unit receives either a power cycle reset, or a soft reset is asserted, the unit will communicate at 115.2k baud and will return "7" on reads to register 432. The same behaviors apply to the parity settings as well.

## 0x2B/0x0E Read Device Identification Get Device Identity (43/14) Details

Device ID codes 1, 2 and 4 are implemented. Device ID code 3 (extended info) is not implemented.

Object IDs

- 0 VendorName
- 1 ProductCode
- 2 MajorMinorRevision
- 3 VendorURL
- 4 ProductName
- 5 ModelName
- 6 UserApplicationName

## Modbus Command Register (400)

### Command Codes

Command	Code (Hex)
Clear motor run hours	66H
Delete last fault from queue	77H
Comm watch dog enable	88H
Comm watch dog disable	99H
Fault reset	AAH
Clear motor start count	BBH
Force ground fault	CCH
Remote off	DDH
Auxiliary relay reset	EEH

**Note:** Command register will clear after being written to.

## Configuration Reset Register (402)

### Reset Codes

Action	Reset Code
Power cycle reset	1
Factory reset	2

## Range Checking

Many configuration parameters are range checked. When implemented, if value is greater than the maximum allowed value, the parameter is set to its maximum. Likewise, if a parameter is set to a value less than its minimum value, the parameter will be set to its minimum value. For function code 0x06, when the range checking causes a value to be different from what is requested to be written, the Modbus response to the 0x06 command returns the requested value, not what was actually written. A subsequent read of this parameter will return the actual value that it was set to.

## Comm Loss Timeout (Reg 440)

Default = 2 seconds

Comm Loss Timeout is the delay between loss of communication (between a comm. module and the base unit) and implemented the comm. loss behavior.

Range is 1–65 seconds, in 1 millisecond increments. For example, to set the comm. loss timeout to 3 seconds, send 3000 to this register.

## Comm Loss Behavior (Reg 441)

Comm Loss Behavior determines what the device should do in the event that communication is lost. If the behavior is enabled, the behavior is implemented after an amount of time equal to the Comm Loss Timeout (Reg 440). Comm Loss Behavior is enabled by writing 88H (Comm Watch Dog Enable) to the Command Register (see Modbus Command Register). Comm Loss Behavior is disabled by writing 99H (Comm Watch Dog Disable) to the Command Register.

### Comm Loss Behavior

Behavior	Reset Code	Notes
Fault	1	Default, if enabled
Hold last state	2	—



Eaton's Electrical Sector is a global leader in power distribution, power quality, control and automation, and monitoring products. When combined with Eaton's full-scale engineering services, these products provide customer-driven PowerChain™ solutions to serve the power system needs of the data center, industrial, institutional, public sector, utility, commercial, residential, IT, mission critical, alternative energy and OEM markets worldwide.

PowerChain solutions help enterprises achieve sustainable and competitive advantages through proactive management of the power system as a strategic, integrated asset throughout its life cycle, resulting in enhanced safety, greater reliability and energy efficiency. For more information, visit [www.eaton.com/electrical](http://www.eaton.com/electrical).

**Eaton Corporation**

Electrical Sector  
1111 Superior Ave.  
Cleveland, OH 44114  
United States  
877-ETN-CARE (877-386-2273)  
[Eaton.com](http://Eaton.com)

©2011 Eaton Corporation  
All Rights Reserved  
Printed in USA  
Publication No. MN04210004E / Z10844  
March 2011



Eaton is a registered trademark of Eaton Corporation. All other trademarks are property of their respective owners.