

RECEIVED: May 4, 2021

REVISED: August 24, 2021

ACCEPTED: September 1, 2021

PUBLISHED: September 29, 2021

Component decompositions and adynkra libraries for supermultiplets in lower dimensional superspaces

S. James Gates Jr., Yangrui Hu and S.-N. Hazel Mak

Brown Theoretical Physics Center,

Box S, 340 Brook Street, Barus Hall, Providence, RI 02912, U.S.A.

Department of Physics, Brown University,

Box 1843, 182 Hope Street, Barus & Holley, Providence, RI 02912, U.S.A.

E-mail: sylvester_gates@brown.edu, yangrui_hu@brown.edu,

sze_ning_mak@brown.edu

ABSTRACT: We present Adynkra Libraries that can be used to explore the embedding of multiplets of component field (whether on-shell or partial on-shell) within Salam-Strathdee superfields for theories in dimension nine through four.

KEYWORDS: Supergravity Models, Superspaces

ARXIV EPRINT: [2007.07390](https://arxiv.org/abs/2007.07390)

Contents

1	Introduction	1
2	Methodology	3
3	9D minimal scalar superfield decomposition	5
3.1	Component decomposition results	5
3.2	9D minimal Adinkra diagram	6
3.3	Young Tableaux descriptions of component fields in 9D minimal scalar superfield	6
3.4	Index structures and irreducible conditions of component fields in 9D minimal scalar superfield	9
4	8D minimal scalar superfield decomposition	13
4.1	Component decomposition results	13
4.2	8D minimal Adinkra diagram	15
4.3	Young Tableaux descriptions of component fields in 8D minimal scalar superfield	15
4.4	Index structures and irreducible conditions of component fields in 8D minimal scalar superfield	19
4.5	(1,0) multiplet decompositions	24
5	7D minimal scalar superfield decomposition	25
5.1	Component decomposition results	25
5.2	7D Minimal Adinkra Diagram	28
5.3	Young Tableaux descriptions of component fields in 7D minimal scalar superfield	29
5.4	Index structures and irreducible conditions of component fields in 7D minimal scalar superfield	31
5.5	(1,0) multiplet decompositions	34
6	6D minimal scalar superfield decomposition	35
6.1	Component decomposition results	35
6.2	6D minimal Adinkra diagram	36
6.3	Young Tableaux descriptions of component fields in 6D minimal scalar superfield	36
6.4	Index structures and irreducible conditions of component fields in 6D minimal scalar superfield	39
6.5	(1,0) multiplet decompositions	40

7	5D minimal scalar superfield decomposition	41
7.1	Component decomposition results	41
7.2	5D minimal Adinkra diagram	42
7.3	Young Tableaux descriptions of component fields in 5D minimal scalar superfield	43
7.4	Index structures and irreducible conditions of component fields in 5D minimal scalar superfield	44
7.5	(1,0) multiplet decompositions	45
8	4D minimal scalar superfield decomposition	46
8.1	Component decomposition results	46
8.2	4D minimal Adinkra diagram	47
8.3	Young Tableaux descriptions of component fields in 4D minimal scalar superfield	47
8.4	Index structures and irreducible conditions of component fields in 4D minimal scalar superfield	48
9	Conclusion	50
A	Irreducible representations	51
B	Projection matrices for branching rules	55
B.1	Minimal scalar superfield decompositions	55
B.2	(1,0) superfield decompositions	56
B.3	A note on the projection matrices of $\mathfrak{su}(8) \supset \mathfrak{so}(8)$ and $\mathfrak{su}(4) \supset \mathfrak{so}(4)$	57
B.4	A note on isomorphisms	58

1 Introduction

In a continuing series of works [1–3], we have been developing a new approach to supersymmetry and supermultiplets that possesses the clarity of traditional component field approaches without their incompleteness. Simultaneously this new approach also retains the completeness of superfield approaches without their opaqueness. Our approach, likely applicable in all dimensions,¹ has led to the construction of “adynkrafields” [3]. Adynkrafields are based on adinkra graphs [4] and Dynkin Labels [5, 6].

An adynkrafield [3] may be obtained by starting with a traditional Salam-Strathdee superfield [7] and replacing the familiar Grassmann coordinate expansions required to derive component results by two distinct types of special configurations of Young Tableaux

¹The realm in which our explicit constructions and discussions have been presented are for 10D and 11D supersymmetrical systems.

(YT's) to derive component results. Both sets of quantities (θ -monomials versus specialized YT combinations) for expansions, respectively, are distinct sets of “basis vectors” for the description of component fields within off-shell supermultiplets.

However, it is important to realize that taking a starting point that solely begins with the considerations of Dynkin Labels, YT's and their properties is *logically viable* and independent of the concept of the Salam-Strathdee superfield. This means that as far as the representation theory of supersymmetry and supermultiplets go, the latter can be entirely replaced by ordinary concepts that exist in Lie Algebra theory without reference to the superfield concept.

The algorithmically superiority of YT-expansions over θ -expansions can be understood by an analogy. It is well known in physics, when a problem has spherical symmetry (take for example the quantum mechanical hydrogen atom) the superior calculational direction is to employ spherical (r, θ, ϕ) coordinates,² not rectilinear (x, y, z) ones. Taking the path of using the triplet (r, θ, ϕ) coordinates leads to the discovery of solutions in terms of “hydrogenic wavefunctions.” If one is engaged in finding numerical solutions for atomic physics problems, efficient algorithms begin with the use of “hydrogenic wavefunctions.” Thus, we assert if one is engaged in finding component results for supersymmetric problems, efficient algorithms begin with the use of adynkrafields, not superfields. The most powerful demonstration of this was given in the work seen in reference [3].

Continuing to use this analogy, when one examines the eigenfunctions of the Laplace operator in three spatial dimensions, the spherical harmonics naturally emerge as the angular portion of it solutions. On the other hand, for the Laplace operator in two spatial dimensions the angular portion of the solution is dominated by complex exponentials. Of course, complex exponentials are a part of the spherical harmonics. This phenomenon of the emergence of a lower dimensional set of orthogonal function under a dimensional reduction is the main point of this current work.

In this approach, all component fields are reduced to two pieces of data, the corresponding Dynkin Label, and the corresponding engineering height. The first piece of data encodes the Lorentz representation of the field and the second controls how a component field can appear in an action. In the construction of adynkras, these two pieces of data are quite simple to track. Thus when one is examining the question of whether there exists a superfield into which any boson-fermion pair can be embedded, on a conceptual basis, the problem becomes identical to one where partial information concerning genetic (DNA/RNA) content (“a snippet”) is known and the question is one of finding the genetic sequence to which the snippet belongs. Another way to describe this is as a “pattern-matching” problem. We are thus in the position to create efficient algorithms capable of answering such questions about the embedding of component fields into superfields.

We wish to show how the adynkras of a theory in a lower spatial dimension emerge from those of a higher dimension. Our starting point will be the adynkra for eleven dimensions. Since we have previously given the answer which emerges from the reduction to nine spatial dimensions, the new results in this work will concentrate on the cases of $4 \leq D \leq 9$. For

²In this triple of coordinates, of course, θ denotes the polar angle, not the Grassmann coordinate.

each of these cases, we will derive the *unconstrained* scalar superfield adynkras that emerge from the reduction from a higher dimension.

In section 2, we briefly review the construction of superspaces in various spacetime dimensions. Two approaches used to construct adynkrafields are reviewed as well. From section 3 to section 8, we present the following from 9D to 4D respectively,

- (a.) Minimal scalar superfield component decompositions into Lorentz representations,
- (b.) Adynkra and Adinkra diagrams,
- (c.) Young Tableaux descriptions of component fields,
- (d.) Index structures and irreducible conditions of each component, and
- (e.) $(1, 0)$ multiplet decompositions.

Note that (e.) only applies to 8D and to 5D.

In each of the dimensions \mathcal{M} of the associated Minkowski space under consideration, the adynkra $\mathcal{V}_{\mathcal{M}}$ associated with the scalar superfield is explicitly presented. This corresponds in every case to a library that explicitly lists the Lorentz representations of all the component fields contained in the scalar superfield appropriate to that dimension. Given the Dynkin Label description of any bosonic irrep (denoted by \mathcal{R}) or any fermionic irrep (denoted by \mathcal{R}), the quantities $\mathcal{V}_{\mathcal{R}} = \mathcal{R} \otimes \mathcal{V}_{\mathcal{M}}$ and $\mathcal{V}_{\mathcal{R}} = \mathcal{R} \otimes \mathcal{V}_{\mathcal{M}}$ respective describe the Lorentz component field contents of *any* superfield over the Minkowski space of dimension \mathcal{M} .

The content of the typical $\mathcal{V}_{\mathcal{M}}$ -library is a listing of Dynkin Labels and the associated heights at which the corresponding irreps appear. For some heights, it is seen that a given Dynkin Label appears with a frequency greater than one. This same phenomenon has been noted previously in the work of [8] where Dynkin Labels have been extensively used to describe the component field content of 11D superfields.³

Section 9 presents our conclusions.

There are two appendices included in this work. Appendix A contains a dictionary between Dynkin Labels and the corresponding representation dimensionalities of Lorentz groups in various spacetime dimensions. Appendix B is devoted to present all necessary projection matrices for the branching rules used to develop minimal scalar superfields and $(1, 0)$ superfields in various spacetime dimensions.

The final portion of this paper includes our references.

2 Methodology

A superspace consists of a set of spacetime coordinates and spinor coordinates. For each spacetime dimension D , there is a specific type of spinors and a minimal number of real components of the spinor coordinates that we call d . This information is listed in table 1. We use the Minkowski signature $(-, +, +, \dots, +)$ in every dimension, and the corresponding Lorentz group is $SO(1, D - 1)$.

³In particular this is seen in the equation listed as (2.7) in this reference.

Spacetime Dimension	Lorentz Group	Type of Spinors	d
11	SO(1,10)	Majorana	32
10	SO(1,9)	Majorana-Weyl	16
9	SO(1,8)	Pseudo-Majorana	16
8	SO(1,7)	Pseudo-Majorana	16
7	SO(1,6)	SU(2)-Majorana	16
6	SO(1,5)	SU(2)-Majorana-Weyl	8
5	SO(1,4)	SU(2)-Majorana	8
4	SO(1,3)	Majorana/Weyl	4

Table 1. Summary of types of spinors in various dimensions [12].

In our previous research work [1, 2], we decomposed each level of the 10D, $\mathcal{N} = 1$, $\mathcal{N} = 2A$, $\mathcal{N} = 2B$, and 11D, $\mathcal{N} = 1$ scalar superfields into Lorentz representations. A scalar superfield with d spinor coordinates can be Taylor expanded into $(d + 1)$ levels — from level-0 (zeroth power of spinor coordinates) to level- d (d -th power of spinor coordinates). In an arbitrary level- n , the decomposition of θ -monomials translates to the antisymmetric product of n spinor representation $\{\mathbf{d}\}$ in $\mathfrak{so}(1, D - 1)$, which we denote by $[\{\mathbf{d}\}^{\otimes n}]_A$ or $\{\mathbf{d}\}^{\wedge n}$. The total degrees of freedom at level- n is the binomial coefficient $\binom{d}{n}$. Note that this is true only for *unconstrained* scalar superfields.

Two methods were used in obtaining the results of the antisymmetric products of each level in terms of direct sums of Lorentz irreducible representations. One utilizes the branching rules $\mathfrak{su}(d) \supset \mathfrak{so}(1, D - 1)$ of the totally antisymmetric irreps in $\mathfrak{su}(d)$ constructed by the fundamental representation $\{\mathbf{d}\}$. These calculations can be accomplished by either Susyno [10] or LieART [11]. Both of them are available online.⁴ The relevant projection matrices used are listed in appendix B. The other one involves the concept of plethysms, and the calculations are done by Susyno [10]. The details of these methods are explained explicitly in chapter 4 of [2].

In [3], there is a complete methodological discussion on how to interpret both the bosonic and the spinorial irreps of $\mathfrak{so}(1, D - 1)$, so that we can translate the scalar superfield components from Dynkin labels to Young Tableaux to field variables, and obtain the corresponding irreducible conditions. One can draw adynkra diagrams to encode all the information of a superfield. The links in the diagrams indicate sufficient but not necessary supersymmetry transformations between component fields, and the algorithm is described in section 8.3 of [3]. These techniques are used in this paper.

⁴The Susyno package is available at <https://renatofonseca.net/susyno>, while the LieART package is available at <https://lieart.hepforge.org/>.

3 9D minimal scalar superfield decomposition

3.1 Component decomposition results

The 9D minimal superfield component decomposition results by Dynkin Labels are shown below.

- Level-0: $[0, 0, 0, 0]$
- Level-1: $[0, 0, 0, 1]$
- Level-2: $[0, 1, 0, 0] \oplus [0, 0, 1, 0]$
- Level-3: $[1, 0, 0, 1] \oplus [0, 1, 0, 1]$
- Level-4: $[2, 0, 0, 0] \oplus [0, 0, 0, 2] \oplus [1, 1, 0, 0] \oplus [0, 2, 0, 0] \oplus [1, 0, 0, 2]$
- Level-5: $[1, 0, 0, 1] \oplus [0, 1, 0, 1] \oplus [2, 0, 0, 1] \oplus [0, 0, 0, 3] \oplus [1, 1, 0, 1]$
- Level-6: $[0, 1, 0, 0] \oplus [0, 0, 1, 0] \oplus [1, 1, 0, 0] \oplus [1, 0, 1, 0] \oplus [2, 1, 0, 0] \oplus [1, 0, 0, 2] \oplus [2, 0, 1, 0] \oplus [0, 1, 0, 2]$
- Level-7: $[0, 0, 0, 1] \oplus [1, 0, 0, 1] \oplus [0, 1, 0, 1] \oplus [2, 0, 0, 1] \oplus [0, 0, 1, 1] \oplus [3, 0, 0, 1] \oplus [1, 1, 0, 1] \oplus [1, 0, 1, 1]$
- Level-8: $[0, 0, 0, 0] \oplus [1, 0, 0, 0] \oplus [2, 0, 0, 0] \oplus [0, 0, 1, 0] \oplus [0, 0, 0, 2] \oplus [3, 0, 0, 0] \oplus [4, 0, 0, 0] \oplus [0, 2, 0, 0] \oplus [1, 0, 1, 0] \oplus [1, 0, 0, 2] \oplus [0, 1, 1, 0] \oplus [0, 0, 2, 0] \oplus [2, 0, 1, 0] \oplus [2, 0, 0, 2]$
- Level-9: $[0, 0, 0, 1] \oplus [1, 0, 0, 1] \oplus [0, 1, 0, 1] \oplus [2, 0, 0, 1] \oplus [0, 0, 1, 1] \oplus [3, 0, 0, 1] \oplus [1, 1, 0, 1] \oplus [1, 0, 1, 1]$
- Level-10: $[0, 1, 0, 0] \oplus [0, 0, 1, 0] \oplus [1, 1, 0, 0] \oplus [1, 0, 1, 0] \oplus [2, 1, 0, 0] \oplus [1, 0, 0, 2] \oplus [2, 0, 1, 0] \oplus [0, 1, 0, 2]$
- Level-11: $[1, 0, 0, 1] \oplus [0, 1, 0, 1] \oplus [2, 0, 0, 1] \oplus [0, 0, 0, 3] \oplus [1, 1, 0, 1]$
- Level-12: $[2, 0, 0, 0] \oplus [0, 0, 0, 2] \oplus [1, 1, 0, 0] \oplus [0, 2, 0, 0] \oplus [1, 0, 0, 2]$
- Level-13: $[1, 0, 0, 1] \oplus [0, 1, 0, 1]$
- Level-14: $[0, 1, 0, 0] \oplus [0, 0, 1, 0]$
- Level-15: $[0, 0, 0, 1]$
- Level-16: $[0, 0, 0, 0]$

The component decomposition results by dimensions are shown below.

- Level-0: $\{1\}$
- Level-1: $\{16\}$

- Level-2: $\{36\} \oplus \{84\}$
- Level-3: $\{128\} \oplus \{432\}$
- Level-4: $\{44\} \oplus \{126\} \oplus \{231\} \oplus \{495\} \oplus \{924\}$
- Level-5: $\{128\} \oplus \{432\} \oplus \{576\} \oplus \{672\} \oplus \{2560\}$
- Level-6: $\{36\} \oplus \{84\} \oplus \{231\} \oplus \{594\} \oplus \{910\} \oplus \{924\} \oplus \{2457\} \oplus \{2772\}$
- Level-7: $\{16\} \oplus \{128\} \oplus \{432\} \oplus \{576\} \oplus \{768\} \oplus \{1920\} \oplus \{2560\} \oplus \{5040\}$
- Level-8: $\{1\} \oplus \{9\} \oplus \{44\} \oplus \{84\} \oplus \{126\} \oplus \{156\} \oplus \{450\} \oplus \{495\} \oplus \{594\} \oplus \{924\} \oplus \{1650\} \oplus \{1980\} \oplus \{2457\} \oplus \{3900\}$
- Level-9: $\{16\} \oplus \{128\} \oplus \{432\} \oplus \{576\} \oplus \{768\} \oplus \{1920\} \oplus \{2560\} \oplus \{5040\}$
- Level-10: $\{36\} \oplus \{84\} \oplus \{231\} \oplus \{594\} \oplus \{910\} \oplus \{924\} \oplus \{2457\} \oplus \{2772\}$
- Level-11: $\{128\} \oplus \{432\} \oplus \{576\} \oplus \{672\} \oplus \{2560\}$
- Level-12: $\{44\} \oplus \{126\} \oplus \{231\} \oplus \{495\} \oplus \{924\}$
- Level-13: $\{128\} \oplus \{432\}$
- Level-14: $\{36\} \oplus \{84\}$
- Level-15: $\{16\}$
- Level-16: $\{1\}$

3.2 9D minimal Adinkra diagram

The component content of 9D minimal scalar superfield (up to Level-5) is summarized in the Adynkra diagram in figure 1 and Adinkra diagram in figure 2. The definitions of Adinkra diagrams in spacetime dimension larger than one and Adynkra diagrams were presented in [1, 3].

3.3 Young Tableaux descriptions of component fields in 9D minimal scalar superfield

In order to establish a graphical language to describe bosonic irreducible representations in $\mathfrak{so}(9)$, we define *irreducible* bosonic Young Tableaux as what we did in 10D [3].

Consider the projection matrix for $\mathfrak{su}(9) \supset \mathfrak{so}(9)$ [9],

$$P_{\mathfrak{su}(9) \supset \mathfrak{so}(9)} = \begin{pmatrix} 1 & 0 & 0 & 0 & 0 & 0 & 0 & 1 \\ 0 & 1 & 0 & 0 & 0 & 0 & 1 & 0 \\ 0 & 0 & 1 & 0 & 0 & 1 & 0 & 0 \\ 0 & 0 & 0 & 2 & 2 & 0 & 0 & 0 \end{pmatrix}. \tag{3.1}$$

The highest weight of a specified irrep of $\mathfrak{su}(9)$ is a row vector $[p_1, p_2, p_3, p_4, p_5, p_6, p_7, p_8]$, where p_1 to p_8 are non-negative integers. Since the $\mathfrak{su}(9)$ YT with n vertical boxes is the

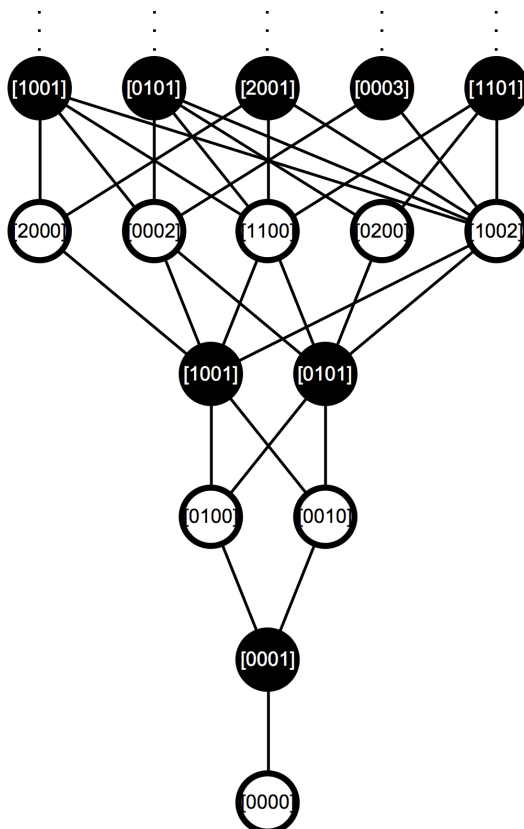

Figure 1. Adynkra Diagram for 9D minimal scalar superfield.

conjugate of the one with $9 - n$ vertical boxes, we need only consider the $p_5 = p_6 = p_7 = p_8 = 0$ case.

Starting from the weight vector $[p_1, p_2, p_3, p_4, 0, 0, 0, 0]$ in $\mathfrak{su}(9)$, we define its projected weight vector $[p_1, p_2, p_3, 2p_4]$ in $\mathfrak{so}(9)$ as the Dynkin Label of the corresponding irreducible bosonic Young Tableau.

$$[p_1, p_2, p_3, 2p_4] = [p_1, p_2, p_3, p_4, 0, 0, 0, 0] P_{\mathfrak{su}(9) \supset \mathfrak{so}(9)}^T. \tag{3.2}$$

Thus, given an irreducible bosonic Young Tableau with p_1 columns of one box, p_2 columns of two vertical boxes, p_3 columns of three vertical boxes, and p_4 columns of four vertical boxes, the Dynkin Label of its corresponding bosonic irrep is $[p_1, p_2, p_3, 2p_4]$. Then look at the congruence classes of a representation with Dynkin Label $[a, b, c, d]$ in $\mathfrak{so}(9)$,

$$C_c(R) := d \pmod{2}. \tag{3.3}$$

$C_c(R)$ classifies the bosonic irreps and spinorial irreps: $C_c(R) = 0$ is bosonic and $C_c(R) = 1$ is spinorial. Consequently, a bosonic irrep satisfies $d = 0 \pmod{2}$.

Therefore, we can reverse this process and show the one-to-one correspondence between bosonic Dynkin Label irreps and irreducible bosonic Young Tableaux. Namely, given a bosonic irrep with Dynkin Label $[a, b, c, d]$, its corresponding irreducible bosonic Young

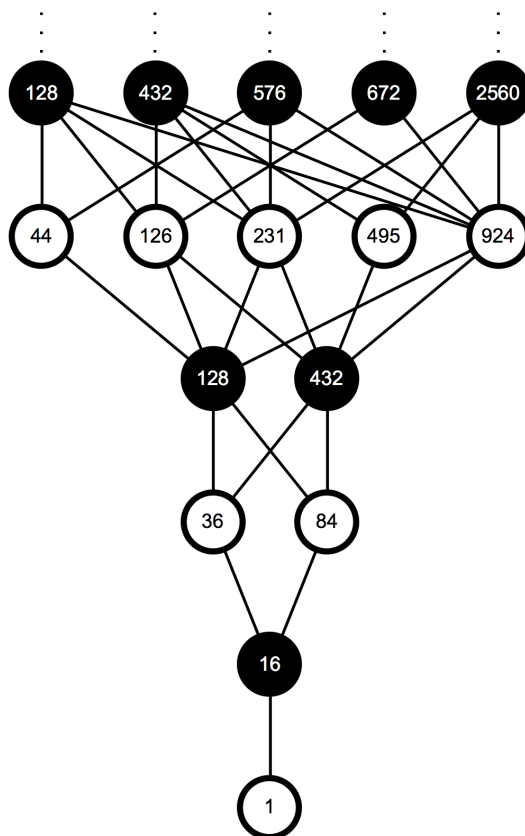

Figure 2. Adinkra Diagram for 9D minimal scalar superfield.

Tableau is composed of a columns of one box, b columns of two vertical boxes, c columns of three vertical boxes, and $d/2$ columns of four vertical boxes.

The simplest examples, also the fundamental building blocks of a BYT, are given below.

$$\begin{array}{ll}
 \square_{\text{IR}} \equiv [1, 0, 0, 0], & \begin{array}{|c|} \hline \square \\ \hline \square \\ \hline \end{array}_{\text{IR}} \equiv [0, 1, 0, 0], \\
 \begin{array}{|c|} \hline \square \\ \hline \square \\ \hline \end{array}_{\text{IR}} \equiv [0, 0, 1, 0], & \begin{array}{|c|} \hline \square \\ \hline \square \\ \hline \square \\ \hline \square \\ \hline \end{array}_{\text{IR}} \equiv [0, 0, 0, 2].
 \end{array} \tag{3.4}$$

The YT's with "IR" subscript subject to certain conditions refer to irreducible representations of $\mathfrak{so}(9)$. YT's without this subscript are reducible with respect to $\mathfrak{so}(9)$ while irreducible with respect to $\mathfrak{su}(9)$. The irreducibility conditions are effectuated by the branching rules for $\mathfrak{su}(9) \supset \mathfrak{so}(9)$, which can also be derived by "tying rules" invented in [3].

For spinorial irreps, the basic SYT is given by

$$\boxed{16} \equiv [0, 0, 0, 1]. \tag{3.5}$$

We could translate the Dynkin Label of any spinorial irrep to a mixed YT (which contains a BYT part and a basic SYT above) with irreducible conditions by applying the same idea discussed in chapter five of [3].

Putting together the columns in (3.4) and (3.5) corresponds to adding their Dynkin Labels.

In summary, the irreducible Young Tableau descriptions of the 9D minimal scalar superfield decomposition is presented below.

$$\mathcal{V} = \left\{ \begin{array}{l}
 \text{Level-0} \quad \cdot, \\
 \text{Level-1} \quad \boxed{16}, \\
 \text{Level-2} \quad \begin{array}{c} \square \\ \square \end{array}_{\text{IR}} \oplus \begin{array}{c} \square \\ \square \\ \square \end{array}_{\text{IR}}, \\
 \text{Level-3} \quad \begin{array}{c} \square \\ \square \end{array}_{\text{IR}} \oplus \begin{array}{c} \square \\ \square \\ \square \\ \square \end{array}_{\text{IR}}, \\
 \text{Level-4} \quad \begin{array}{c} \square \\ \square \end{array}_{\text{IR}} \oplus \begin{array}{c} \square \\ \square \\ \square \end{array}_{\text{IR}} \oplus \begin{array}{c} \square \\ \square \\ \square \\ \square \end{array}_{\text{IR}} \oplus \begin{array}{c} \square \\ \square \\ \square \\ \square \\ \square \end{array}_{\text{IR}} \oplus \begin{array}{c} \square \\ \square \\ \square \\ \square \\ \square \\ \square \end{array}_{\text{IR}}, \\
 \text{Level-5} \quad \begin{array}{c} \square \\ \square \\ \square \\ \square \\ \square \end{array}_{\text{IR}} \oplus \begin{array}{c} \square \\ \square \\ \square \\ \square \\ \square \\ \square \end{array}_{\text{IR}} \oplus \begin{array}{c} \square \\ \square \\ \square \\ \square \\ \square \\ \square \\ \square \end{array}_{\text{IR}} \oplus \begin{array}{c} \square \\ \square \\ \square \\ \square \\ \square \\ \square \\ \square \\ \square \end{array}_{\text{IR}} \oplus \begin{array}{c} \square \\ \square \\ \square \\ \square \\ \square \\ \square \\ \square \\ \square \\ \square \end{array}_{\text{IR}}, \\
 \text{Level-6} \quad \begin{array}{c} \square \\ \square \\ \square \\ \square \\ \square \end{array}_{\text{IR}} \oplus \begin{array}{c} \square \\ \square \\ \square \\ \square \\ \square \\ \square \end{array}_{\text{IR}} \oplus \begin{array}{c} \square \\ \square \\ \square \\ \square \\ \square \\ \square \\ \square \end{array}_{\text{IR}} \oplus \begin{array}{c} \square \\ \square \\ \square \\ \square \\ \square \\ \square \\ \square \\ \square \end{array}_{\text{IR}} \oplus \begin{array}{c} \square \\ \square \\ \square \\ \square \\ \square \\ \square \\ \square \\ \square \\ \square \end{array}_{\text{IR}} \oplus \begin{array}{c} \square \\ \square \\ \square \\ \square \\ \square \\ \square \\ \square \\ \square \\ \square \\ \square \end{array}_{\text{IR}} \oplus \begin{array}{c} \square \\ \square \\ \square \\ \square \\ \square \\ \square \\ \square \\ \square \\ \square \\ \square \\ \square \end{array}_{\text{IR}}, \\
 \text{Level-7} \quad \begin{array}{c} \square \\ \square \\ \square \\ \square \\ \square \end{array}_{\text{IR}} \oplus \begin{array}{c} \square \\ \square \\ \square \\ \square \\ \square \\ \square \end{array}_{\text{IR}} \oplus \begin{array}{c} \square \\ \square \\ \square \\ \square \\ \square \\ \square \\ \square \end{array}_{\text{IR}} \oplus \begin{array}{c} \square \\ \square \\ \square \\ \square \\ \square \\ \square \\ \square \\ \square \end{array}_{\text{IR}} \oplus \begin{array}{c} \square \\ \square \\ \square \\ \square \\ \square \\ \square \\ \square \\ \square \\ \square \end{array}_{\text{IR}} \oplus \begin{array}{c} \square \\ \square \\ \square \\ \square \\ \square \\ \square \\ \square \\ \square \\ \square \\ \square \\ \square \end{array}_{\text{IR}} \oplus \begin{array}{c} \square \\ \square \\ \square \\ \square \\ \square \\ \square \\ \square \\ \square \\ \square \\ \square \\ \square \\ \square \end{array}_{\text{IR}} \oplus \begin{array}{c} \square \\ \square \\ \square \\ \square \\ \square \\ \square \\ \square \\ \square \\ \square \\ \square \\ \square \\ \square \\ \square \end{array}_{\text{IR}}, \\
 \text{Level-8} \quad \cdot \oplus \begin{array}{c} \square \\ \square \\ \square \\ \square \\ \square \end{array}_{\text{IR}} \oplus \begin{array}{c} \square \\ \square \\ \square \\ \square \\ \square \\ \square \end{array}_{\text{IR}} \oplus \begin{array}{c} \square \\ \square \\ \square \\ \square \\ \square \\ \square \\ \square \end{array}_{\text{IR}} \oplus \begin{array}{c} \square \\ \square \\ \square \\ \square \\ \square \\ \square \\ \square \\ \square \end{array}_{\text{IR}} \oplus \begin{array}{c} \square \\ \square \\ \square \\ \square \\ \square \\ \square \\ \square \\ \square \\ \square \end{array}_{\text{IR}} \oplus \begin{array}{c} \square \\ \square \\ \square \\ \square \\ \square \\ \square \\ \square \\ \square \\ \square \\ \square \end{array}_{\text{IR}} \oplus \begin{array}{c} \square \\ \square \\ \square \\ \square \\ \square \\ \square \\ \square \\ \square \\ \square \\ \square \\ \square \end{array}_{\text{IR}} \oplus \begin{array}{c} \square \\ \square \\ \square \\ \square \\ \square \\ \square \\ \square \\ \square \\ \square \\ \square \\ \square \end{array}_{\text{IR}} \oplus \begin{array}{c} \square \\ \square \\ \square \\ \square \\ \square \\ \square \\ \square \\ \square \\ \square \\ \square \\ \square \end{array}_{\text{IR}}, \\
 \vdots \quad \quad \quad \vdots
 \end{array} \right. \tag{3.6}$$

where Level-9 to Level-16 have exactly the same expressions as Level-7 to Level-0.

3.4 Index structures and irreducible conditions of component fields in 9D minimal scalar superfield

In this section, we will translate the irreducible bosonic and mixed Young Tableaux into field variables. In order to express the index structure clearly and efficiently, we introduce

the following notational conventions for irreducible bosonic YT. We use “|” to separate indices in YT with different heights and “,” to separate indices in YT with the same heights.

The vector index \underline{a} runs from 0 to 8. In fact, the $\{\}$ -indices, irreducible bosonic Young Tableaux, and Dynkin Labels are equivalent and have the one-to-one correspondence.

The general expression is as below in equations (3.7) and (3.8),

$$\{ \underline{a}_1, \dots, \underline{a}_p \mid \underline{b}_1 \underline{c}_1, \dots, \underline{b}_q \underline{c}_q \mid \underline{d}_1 \underline{e}_1 \underline{f}_1, \dots, \underline{d}_r \underline{e}_r \underline{f}_r \mid \underline{g}_1 \underline{h}_1 \underline{i}_1 \underline{j}_1, \dots, \underline{g}_s \underline{h}_s \underline{i}_s \underline{j}_s \} \quad (3.7)$$

$\begin{array}{|c|} \hline \underline{a}_1 \\ \hline \end{array}$
 $[p, 0, 0, 0]$

$\begin{array}{|c|} \hline \underline{a}_p \\ \hline \end{array}$
 $[0, q, 0, 0]$

$\begin{array}{|c|} \hline \underline{b}_1 \\ \hline \underline{c}_1 \\ \hline \end{array}$
 $[0, 0, r, 0]$

$\begin{array}{|c|} \hline \underline{b}_q \\ \hline \underline{c}_q \\ \hline \end{array}$
 $[0, 0, r, 0]$

$\begin{array}{|c|} \hline \underline{d}_1 \\ \hline \underline{e}_1 \\ \hline \underline{f}_1 \\ \hline \end{array}$
 $[0, 0, r, 0]$

$\begin{array}{|c|} \hline \underline{d}_r \\ \hline \underline{e}_r \\ \hline \underline{f}_r \\ \hline \end{array}$
 $[0, 0, r, 0]$

$\begin{array}{|c|} \hline \underline{g}_1 \\ \hline \underline{h}_1 \\ \hline \underline{i}_1 \\ \hline \underline{j}_1 \\ \hline \end{array}$
 $[0, 0, 0, 2s]$

$\begin{array}{|c|} \hline \underline{g}_s \\ \hline \underline{h}_s \\ \hline \underline{i}_s \\ \hline \underline{j}_s \\ \hline \end{array}$
 $[0, 0, 0, 2s]$

where above we have “disassembled” the YT to show how each column is affiliated with each type of subscript structure. Below we have assembled all the columns into a proper YT.

$$\begin{array}{|c|c|c|c|c|c|c|c|c|c|} \hline \underline{g}_1 & \dots & \underline{g}_s & \underline{d}_1 & \dots & \underline{d}_r & \underline{b}_1 & \dots & \underline{b}_q & \underline{a}_1 & \dots & \underline{a}_p \\ \hline \underline{h}_1 & \dots & \underline{h}_s & \underline{e}_1 & \dots & \underline{e}_r & \underline{c}_1 & \dots & \underline{c}_q & & & \\ \hline \underline{i}_1 & \dots & \underline{i}_s & \underline{f}_1 & \dots & \underline{f}_r & & & & & & \\ \hline \underline{j}_1 & \dots & \underline{j}_s & & & & & & & & & \\ \hline \end{array} \quad \text{IR} \quad (3.8)$$

$[p, q, r, 2s]$

As one moves from the YT’s shown in equation (3.7) to equation (3.8), it is clear the number of vertical boxes is tabulating the number of 1-forms, 2-forms, 3-forms, and 4-forms in the YT’s. These are the entries between the vertical | bars. These precisely correspond to the integers $p, q, r,$ and s in the Dynkin Labels. An example of the correspondence between the subscript conventions, the affiliated YT, and Dynkin Label is shown in (3.9).

$$\{ \underline{a}_2, \underline{a}_3 \mid \underline{a}_1 \underline{b}_1 \underline{c}_1 \underline{d}_1 \} \equiv \begin{array}{|c|c|c|} \hline \underline{a}_1 & \underline{a}_2 & \underline{a}_3 \\ \hline \underline{b}_1 & & \\ \hline \underline{c}_1 & & \\ \hline \underline{d}_1 & & \\ \hline \end{array} \equiv [2, 0, 0, 2] . \quad (3.9)$$

IR

The index structures as well as irreducible conditions of all bosonic and fermionic fields are identified below along with the level at which the fields occur in the adinkra of the superfield. The spinor index α runs from 1 to 16.

- Level-0: $\Phi(x)$,
- Level-1: $\Psi_\alpha(x)$,
- Level-2: $\Phi_{\{\underline{a}_1 \underline{b}_1\}}(x)$, $\Phi_{\{\underline{a}_1 \underline{b}_1 \underline{c}_1\}}(x)$,
- Level-3: $\Psi_{\{\underline{a}_1\}\alpha}(x) : (\gamma^{\underline{a}_1})_\beta{}^\alpha \Psi_{\{\underline{a}_1\}\alpha}(x) = 0$, $\Psi_{\{\underline{a}_1 \underline{b}_1\}\alpha}(x) : (\gamma^{\underline{a}_1})_\beta{}^\alpha \Psi_{\{\underline{a}_1 \underline{b}_1\}\alpha}(x) = 0$,

$$\Psi_{\{a_2|a_1b_1\}\alpha}(x) : \begin{cases} (\gamma^{b_1})_\beta^\alpha \Psi_{\{a_2|a_1b_1\}\alpha}(x) \equiv \psi_{\{a_1,a_2\}\beta} = 0, \\ (\gamma^{a_2})_\beta^\alpha \Psi_{\{a_2|a_1b_1\}\alpha}(x) \equiv \psi_{\{a_1b_1\}\beta} = 0, \\ (\gamma^{b_1})_\gamma^\beta \psi_{\{a_1b_1\}\beta} = 0, \end{cases}$$

$$\Psi_{\{a_2|a_1b_1c_1\}\alpha}(x) : \begin{cases} (\gamma^{c_1})_\beta^\alpha \Psi_{\{a_2|a_1b_1c_1\}\alpha}(x) \equiv \psi_{\{a_2|a_1b_1\}\beta} = 0, \\ (\gamma^{a_2})_\beta^\alpha \Psi_{\{a_2|a_1b_1c_1\}\alpha}(x) \equiv \psi_{\{a_1b_1c_1\}\beta} = 0, \\ (\gamma^{c_1})_\gamma^\beta \psi_{\{a_1b_1c_1\}\beta} = 0, \end{cases}$$

• Level-8: $\Phi(x)$, $\Phi_{\{a_1\}}(x)$, $\Phi_{\{a_1,a_2\}}(x) : \eta^{a_1a_2}\Phi_{\{a_1,a_2\}}(x) = 0$,

$$\Phi_{\{a_1,a_2,a_3\}}(x) : \eta^{a_1a_2}\Phi_{\{a_1,a_2,a_3\}}(x) = 0,$$

$$\Phi_{\{a_1,a_2,a_3,a_4\}}(x) : \begin{cases} \eta^{a_1a_2}\Phi_{\{a_1,a_2,a_3,a_4\}}(x) = 0, \\ \eta^{a_1a_2}\eta^{a_3a_4}\Phi_{\{a_1,a_2,a_3,a_4\}}(x) = 0, \end{cases}$$

$$\Phi_{\{a_1b_1,a_2b_2\}}(x) : \begin{cases} \eta^{a_1a_2}\Phi_{\{a_1b_1,a_2b_2\}}(x) = 0, \\ \eta^{a_1a_2}\eta^{b_1b_2}\Phi_{\{a_1b_1,a_2b_2\}}(x) = 0, \end{cases}$$

$$\Phi_{\{a_2b_2|a_1b_1c_1\}}(x) : \begin{cases} \eta^{a_1a_2}\Phi_{\{a_2b_2|a_1b_1c_1\}}(x) = 0, \\ \eta^{a_1a_2}\eta^{b_1b_2}\Phi_{\{a_2b_2|a_1b_1c_1\}}(x) = 0, \end{cases}$$

$$\Phi_{\{a_1b_1c_1,a_2b_2c_2\}}(x) : \begin{cases} \eta^{a_1a_2}\Phi_{\{a_1b_1c_1,a_2b_2c_2\}}(x) = 0, \\ \eta^{a_1a_2}\eta^{b_1b_2}\Phi_{\{a_1b_1c_1,a_2b_2c_2\}}(x) = 0, \\ \eta^{a_1a_2}\eta^{b_1b_2}\eta^{c_1c_2}\Phi_{\{a_1b_1c_1,a_2b_2c_2\}}(x) = 0, \end{cases}$$

$$\Phi_{\{a_1b_1c_1\}}(x), \quad \Phi_{\{a_1b_1c_1d_1\}}(x), \quad \Phi_{\{a_2|a_1b_1c_1\}}(x) : \eta^{a_1a_2}\Phi_{\{a_2|a_1b_1c_1\}}(x) = 0,$$

$$\Phi_{\{a_2|a_1b_1c_1d_1\}}(x) : \eta^{a_1a_2}\Phi_{\{a_2|a_1b_1c_1d_1\}}(x) = 0,$$

$$\Phi_{\{a_2,a_3|a_1b_1c_1\}}(x) : \begin{cases} \eta^{a_2a_3}\Phi_{\{a_2,a_3|a_1b_1c_1\}}(x) = 0, \\ \eta^{c_1a_3}\Phi_{\{a_2,a_3|a_1b_1c_1\}}(x) = 0, \end{cases}$$

$$\Phi_{\{a_2,a_3|a_1b_1c_1d_1\}}(x) : \begin{cases} \eta^{a_2a_3}\Phi_{\{a_2,a_3|a_1b_1c_1d_1\}}(x) = 0, \\ \eta^{d_1a_3}\Phi_{\{a_2,a_3|a_1b_1c_1d_1\}}(x) = 0. \end{cases}$$

Level-9 to Level-16 have exactly the same expressions as Level-7 to Level-0.

4 8D minimal scalar superfield decomposition

4.1 Component decomposition results

The 8D minimal superfield component decomposition results in terms of Dynkin Labels are shown below.

- Level-0: $[0, 0, 0, 0]$
- Level-1: $[0, 0, 0, 1] \oplus [0, 0, 1, 0]$
- Level-2: $[1, 0, 0, 0] \oplus (2)[0, 1, 0, 0] \oplus [0, 0, 1, 1]$
- Level-3: $[0, 0, 0, 1] \oplus [0, 0, 1, 0] \oplus (2)[1, 0, 1, 0] \oplus (2)[1, 0, 0, 1] \oplus [0, 1, 0, 1] \oplus [0, 1, 1, 0]$
- Level-4: $[0, 0, 0, 0] \oplus (2)[1, 0, 0, 0] \oplus [0, 1, 0, 0] \oplus (3)[2, 0, 0, 0] \oplus (2)[0, 0, 2, 0] \oplus (2)[0, 0, 0, 2] \oplus (2)[0, 0, 1, 1] \oplus (2)[1, 1, 0, 0] \oplus [1, 0, 2, 0] \oplus [1, 0, 0, 2] \oplus [0, 2, 0, 0] \oplus [1, 0, 1, 1]$
- Level-5: $(2)[0, 0, 0, 1] \oplus (2)[0, 0, 1, 0] \oplus (4)[1, 0, 1, 0] \oplus (4)[1, 0, 0, 1] \oplus [0, 0, 0, 3] \oplus [0, 0, 3, 0] \oplus (2)[0, 1, 0, 1] \oplus (2)[0, 1, 1, 0] \oplus (2)[2, 0, 0, 1] \oplus [0, 0, 2, 1] \oplus (2)[2, 0, 1, 0] \oplus [0, 0, 1, 2] \oplus [1, 1, 1, 0] \oplus [1, 1, 0, 1]$
- Level-6: $(3)[1, 0, 0, 0] \oplus (6)[0, 1, 0, 0] \oplus (2)[2, 0, 0, 0] \oplus [0, 0, 2, 0] \oplus [0, 0, 0, 2] \oplus (4)[0, 0, 1, 1] \oplus [3, 0, 0, 0] \oplus (4)[1, 1, 0, 0] \oplus (2)[1, 0, 2, 0] \oplus (2)[1, 0, 0, 2] \oplus (4)[1, 0, 1, 1] \oplus (2)[2, 1, 0, 0] \oplus [0, 1, 2, 0] \oplus [0, 1, 0, 2] \oplus [0, 1, 1, 1] \oplus [2, 0, 1, 1]$
- Level-7: $(4)[0, 0, 0, 1] \oplus (4)[0, 0, 1, 0] \oplus (5)[1, 0, 1, 0] \oplus (5)[1, 0, 0, 1] \oplus (4)[0, 1, 0, 1] \oplus (4)[0, 1, 1, 0] \oplus (3)[2, 0, 0, 1] \oplus (2)[0, 0, 2, 1] \oplus (3)[2, 0, 1, 0] \oplus (2)[0, 0, 1, 2] \oplus [3, 0, 1, 0] \oplus [3, 0, 0, 1] \oplus (2)[1, 1, 1, 0] \oplus (2)[1, 1, 0, 1] \oplus [1, 0, 1, 2] \oplus [1, 0, 2, 1]$
- Level-8: $(5)[0, 0, 0, 0] \oplus (4)[1, 0, 0, 0] \oplus (3)[0, 1, 0, 0] \oplus (4)[2, 0, 0, 0] \oplus (3)[0, 0, 2, 0] \oplus (3)[0, 0, 0, 2] \oplus (6)[0, 0, 1, 1] \oplus (2)[3, 0, 0, 0] \oplus (4)[1, 1, 0, 0] \oplus (2)[1, 0, 2, 0] \oplus (2)[1, 0, 0, 2] \oplus [4, 0, 0, 0] \oplus (3)[0, 2, 0, 0] \oplus (5)[1, 0, 1, 1] \oplus [2, 1, 0, 0] \oplus (2)[0, 1, 1, 1] \oplus [2, 0, 2, 0] \oplus [2, 0, 0, 2] \oplus [0, 0, 2, 2] \oplus (2)[2, 0, 1, 1]$
- Level-9: $(4)[0, 0, 0, 1] \oplus (4)[0, 0, 1, 0] \oplus (5)[1, 0, 1, 0] \oplus (5)[1, 0, 0, 1] \oplus (4)[0, 1, 0, 1] \oplus (4)[0, 1, 1, 0] \oplus (3)[2, 0, 0, 1] \oplus (2)[0, 0, 2, 1] \oplus (3)[2, 0, 1, 0] \oplus (2)[0, 0, 1, 2] \oplus [3, 0, 1, 0] \oplus [3, 0, 0, 1] \oplus (2)[1, 1, 1, 0] \oplus (2)[1, 1, 0, 1] \oplus [1, 0, 1, 2] \oplus [1, 0, 2, 1]$
- Level-10: $(3)[1, 0, 0, 0] \oplus (6)[0, 1, 0, 0] \oplus (2)[2, 0, 0, 0] \oplus [0, 0, 2, 0] \oplus [0, 0, 0, 2] \oplus (4)[0, 0, 1, 1] \oplus [3, 0, 0, 0] \oplus (4)[1, 1, 0, 0] \oplus (2)[1, 0, 2, 0] \oplus (2)[1, 0, 0, 2] \oplus (4)[1, 0, 1, 1] \oplus (2)[2, 1, 0, 0] \oplus [0, 1, 2, 0] \oplus [0, 1, 0, 2] \oplus [0, 1, 1, 1] \oplus [2, 0, 1, 1]$
- Level-11: $(2)[0, 0, 0, 1] \oplus (2)[0, 0, 1, 0] \oplus (4)[1, 0, 1, 0] \oplus (4)[1, 0, 0, 1] \oplus [0, 0, 0, 3] \oplus [0, 0, 3, 0] \oplus (2)[0, 1, 0, 1] \oplus (2)[0, 1, 1, 0] \oplus (2)[2, 0, 0, 1] \oplus [0, 0, 2, 1] \oplus (2)[2, 0, 1, 0] \oplus [0, 0, 1, 2] \oplus [1, 1, 1, 0] \oplus [1, 1, 0, 1]$
- Level-12: $[0, 0, 0, 0] \oplus (2)[1, 0, 0, 0] \oplus [0, 1, 0, 0] \oplus (3)[2, 0, 0, 0] \oplus (2)[0, 0, 2, 0] \oplus (2)[0, 0, 0, 2] \oplus (2)[0, 0, 1, 1] \oplus (2)[1, 1, 0, 0] \oplus [1, 0, 2, 0] \oplus [1, 0, 0, 2] \oplus [0, 2, 0, 0] \oplus [1, 0, 1, 1]$

- Level-13: $[0, 0, 0, 1] \oplus [0, 0, 1, 0] \oplus (2)[1, 0, 1, 0] \oplus (2)[1, 0, 0, 1] \oplus [0, 1, 0, 1] \oplus [0, 1, 1, 0]$
- Level-14: $[1, 0, 0, 0] \oplus (2)[0, 1, 0, 0] \oplus [0, 0, 1, 1]$
- Level-15: $[0, 0, 0, 1] \oplus [0, 0, 1, 0]$
- Level-16: $[0, 0, 0, 0]$

The component decomposition results by dimensions are shown below.

- Level-0: $\{1\}$
- Level-1: $\{8_s\} \oplus \{8_c\}$
- Level-2: $\{8_v\} \oplus (2)\{28\} \oplus \{56_v\}$
- Level-3: $\{8_s\} \oplus \{8_c\} \oplus (2)\{56_s\} \oplus (2)\{56_c\} \oplus \{160_s\} \oplus \{160_c\}$
- Level-4: $\{1\} \oplus (2)\{8_v\} \oplus \{28\} \oplus (3)\{35_v\} \oplus (2)\{35_c\} \oplus (2)\{35_s\} \oplus (2)\{56_v\} \oplus (2)\{160_v\} \oplus \{224_{cv}\} \oplus \{224_{sv}\} \oplus \{300\} \oplus \{350\}$
- Level-5: $(2)\{8_s\} \oplus (2)\{8_c\} \oplus (4)\{56_s\} \oplus (4)\{56_c\} \oplus \{112_s\} \oplus \{112_c\} \oplus (2)\{160_s\} \oplus (2)\{160_c\} \oplus (2)\{224_{vs}\} \oplus \{224_{cs}\} \oplus (2)\{224_{vc}\} \oplus \{224_{sc}\} \oplus \{840_s\} \oplus \{840_c\}$
- Level-6: $(3)\{8_v\} \oplus (6)\{28\} \oplus (2)\{35_v\} \oplus \{35_c\} \oplus \{35_s\} \oplus (4)\{56_v\} \oplus \{112_v\} \oplus (4)\{160_v\} \oplus (2)\{224_{cv}\} \oplus (2)\{224_{sv}\} \oplus (4)\{350\} \oplus (2)\{567_v\} \oplus \{567_c\} \oplus \{567_s\} \oplus \{840_v\} \oplus \{1296_v\}$
- Level-7: $(4)\{8_s\} \oplus (4)\{8_c\} \oplus (5)\{56_s\} \oplus (5)\{56_c\} \oplus (4)\{160_s\} \oplus (4)\{160_c\} \oplus (3)\{224_{vs}\} \oplus (2)\{224_{cs}\} \oplus (3)\{224_{vc}\} \oplus (2)\{224_{sc}\} \oplus \{672_{vc}\} \oplus \{672_{vs}\} \oplus (2)\{840_s\} \oplus (2)\{840_c\} \oplus \{1296_s\} \oplus \{1296_c\}$
- Level-8: $(5)\{1\} \oplus (4)\{8_v\} \oplus (3)\{28\} \oplus (4)\{35_v\} \oplus (3)\{35_c\} \oplus (3)\{35_s\} \oplus (6)\{56_v\} \oplus (2)\{112_v\} \oplus (4)\{160_v\} \oplus (2)\{224_{cv}\} \oplus (2)\{224_{sv}\} \oplus \{294_v\} \oplus (3)\{300\} \oplus (5)\{350\} \oplus \{567_v\} \oplus (2)\{840_v\} \oplus \{840'_s\} \oplus \{840'_c\} \oplus \{840'_v\} \oplus (2)\{1296_v\}$
- Level-9: $(4)\{8_s\} \oplus (4)\{8_c\} \oplus (5)\{56_s\} \oplus (5)\{56_c\} \oplus (4)\{160_s\} \oplus (4)\{160_c\} \oplus (3)\{224_{vs}\} \oplus (2)\{224_{cs}\} \oplus (3)\{224_{vc}\} \oplus (2)\{224_{sc}\} \oplus \{672_{vc}\} \oplus \{672_{vs}\} \oplus (2)\{840_s\} \oplus (2)\{840_c\} \oplus \{1296_s\} \oplus \{1296_c\}$
- Level-10: $(3)\{8_v\} \oplus (6)\{28\} \oplus (2)\{35_v\} \oplus \{35_c\} \oplus \{35_s\} \oplus (4)\{56_v\} \oplus \{112_v\} \oplus (4)\{160_v\} \oplus (2)\{224_{cv}\} \oplus (2)\{224_{sv}\} \oplus (4)\{350\} \oplus (2)\{567_v\} \oplus \{567_c\} \oplus \{567_s\} \oplus \{840_v\} \oplus \{1296_v\}$
- Level-11: $(2)\{8_s\} \oplus (2)\{8_c\} \oplus (4)\{56_s\} \oplus (4)\{56_c\} \oplus \{112_s\} \oplus \{112_c\} \oplus (2)\{160_s\} \oplus (2)\{160_c\} \oplus (2)\{224_{vs}\} \oplus \{224_{cs}\} \oplus (2)\{224_{vc}\} \oplus \{224_{sc}\} \oplus \{840_s\} \oplus \{840_c\}$
- Level-12: $\{1\} \oplus (2)\{8_v\} \oplus \{28\} \oplus (3)\{35_v\} \oplus (2)\{35_c\} \oplus (2)\{35_s\} \oplus (2)\{56_v\} \oplus (2)\{160_v\} \oplus \{224_{cv}\} \oplus \{224_{sv}\} \oplus \{300\} \oplus \{350\}$
- Level-13: $\{8_s\} \oplus \{8_c\} \oplus (2)\{56_s\} \oplus (2)\{56_c\} \oplus \{160_s\} \oplus \{160_c\}$
- Level-14: $\{8_v\} \oplus (2)\{28\} \oplus \{56_v\}$

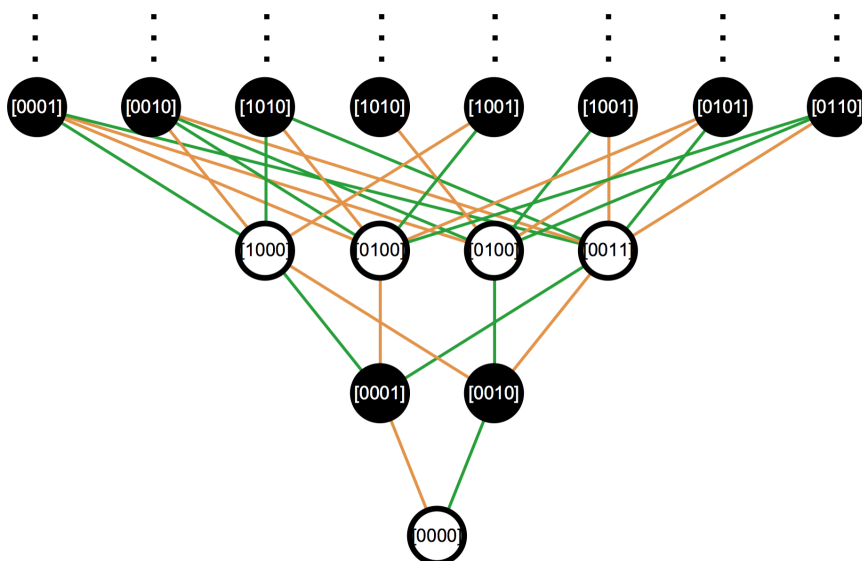

Figure 3. Adynkra Diagram for 8D minimal scalar superfield.

- Level-15: $\{8_s\} \oplus \{8_c\}$
- Level-16: $\{1\}$

4.2 8D minimal Adinkra diagram

The Adynkra and Adinkra diagrams for 8D minimal scalar superfield (up to Level-3) are figure 3 and 4. In eight dimensions, we have two types of spinors having opposite chirality. Thus we have two types of spinorial derivatives D_α and \bar{D}_α . In figures 3 and 4 we use orange links to denote the supersymmetry transformations carried by D_α and green links for \bar{D}_α .

4.3 Young Tableaux descriptions of component fields in 8D minimal scalar superfield

Consider the projection matrix for $\mathfrak{su}(8) \supset \mathfrak{so}(8)$ [9],

$$P_{\mathfrak{su}(8) \supset \mathfrak{so}(8)} = \begin{pmatrix} 1 & 0 & 0 & 0 & 0 & 0 & 1 \\ 0 & 1 & 0 & 0 & 0 & 1 & 0 \\ 0 & 0 & 1 & 0 & 1 & 0 & 0 \\ 0 & 0 & 1 & 2 & 1 & 0 & 0 \end{pmatrix}. \tag{4.1}$$

The highest weight of a specified irrep of $\mathfrak{su}(8)$ is a row vector $[p_1, p_2, p_3, p_4, p_5, p_6, p_7]$, where p_1 to p_7 are non-negative integers. Since the $\mathfrak{su}(8)$ YT with n vertical boxes is the conjugate of the one with $8 - n$ vertical boxes, we need only consider the $p_5 = p_6 = p_7 = 0$ case.

Starting from the weight vector $[p_1, p_2, p_3, p_4, 0, 0, 0]$ in $\mathfrak{su}(8)$, we define its projected weight vector $[p_1, p_2, p_3, p_3 + 2p_4]$ in $\mathfrak{so}(8)$ as the Dynkin Label of the corresponding irreducible bosonic Young Tableau.

$$[p_1, p_2, p_3, p_3 + 2p_4] = [p_1, p_2, p_3, p_4, 0, 0, 0] P_{\mathfrak{su}(8) \supset \mathfrak{so}(8)}^T. \tag{4.2}$$

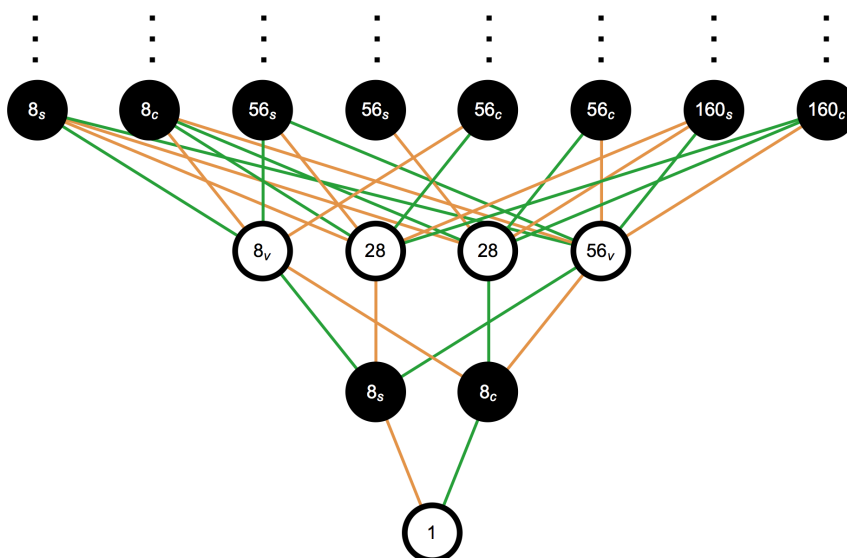

Figure 4. Adinkra Diagram for 8D minimal scalar superfield.

Note that in 8D, duality condition needs to be considered for the four-form. Similar as the situation in 10D discussed in [3], the Dynkin Label $[p_1, p_2, p_3 + 2p_4, p_3]$ carries the same dimensionality and corresponds to the same YT shape as $[p_1, p_2, p_3, p_3 + 2p_4]$, although there's no complex conjugation in $\mathfrak{so}(8)$ and all irreps are real. Then look at the congruence classes of a representation with Dynkin Label $[a, b, c, d]$ in $\mathfrak{so}(8)$,

$$\begin{aligned} C_{c1}(R) &:= c + d \pmod{2}, \\ C_{c2}(R) &:= 2a + 2c + 4d \pmod{4}. \end{aligned} \tag{4.3}$$

Based on the above equations, there are totally four congruence classes in $\mathfrak{so}(8)$,

$$[C_{c1}, C_{c2}](R) = \begin{cases} [0, 0] \\ [0, 2] \\ [1, 0] \\ [1, 2] \end{cases}. \tag{4.4}$$

$C_{c1}(R)$ actually classifies the bosonic irreps and spinorial irreps: $C_{c1}(R) = 0$ is bosonic and $C_{c1}(R) = 1$ is spinorial. Consequently, a bosonic irrep satisfies $c - d = 0 \pmod{2}$.

Thus, given an irreducible bosonic Young Tableau with p_1 columns of one box, p_2 columns of two vertical boxes, p_3 columns of three vertical boxes, and p_4 columns of four vertical boxes, the Dynkin Label of its corresponding bosonic irrep is $[p_1, p_2, p_3, p_3 + 2p_4]$ (or $[p_1, p_2, p_3 + 2p_4, p_3]$). Reversely, given a bosonic irrep with Dynkin Label $[a, b, c, d]$, its corresponding irreducible bosonic Young Tableau is composed of a columns of one box, b columns of two vertical boxes, $\min\{c, d\}$ columns of three vertical boxes, and $|d - c|/2$ columns of four vertical boxes.

The simplest examples, also the fundamental building blocks of an irreducible BYT, are given below.

$$\begin{aligned}
 \square_{\text{IR}} &\equiv [1, 0, 0, 0], & \begin{array}{|c|} \hline \square \\ \hline \end{array}_{\text{IR}} &\equiv [0, 1, 0, 0], & \begin{array}{|c|c|} \hline \square & \square \\ \hline \end{array}_{\text{IR}} &\equiv [0, 0, 1, 1], \\
 \begin{array}{|c|c|c|} \hline \square & \square & \square \\ \hline \end{array}_{\text{IR,S}} &\equiv [0, 0, 0, 2], & \begin{array}{|c|c|c|} \hline \square & \square & \square \\ \hline \end{array}_{\text{IR,C}} &\equiv [0, 0, 2, 0],
 \end{aligned} \tag{4.5}$$

For spinorial irreps, the basic SYTs are given by

$$\begin{aligned}
 \boxed{8_s} &\equiv [0, 0, 0, 1], \\
 \boxed{8_c} &\equiv [0, 0, 1, 0].
 \end{aligned} \tag{4.6}$$

We could translate the Dynkin Label of any spinorial irrep to a mixed YT (which contains a BYT part and one of the basic SYT above) with irreducible conditions by applying the same idea discussed in chapter five in [3].

Putting together the columns in (4.5) and (4.6) corresponds to adding their Dynkin Labels. We follow the well-known (VCS) convention for labelling $\mathfrak{so}(8)$ irreps to name our irreducible YTs.

In summary, the irreducible Young Tableau descriptions of the 8D minimal scalar superfield decomposition is presented below.

- Level-0: \cdot ,
- Level-1: $\boxed{8_s} \oplus \boxed{8_c}$,
- Level-2: $\square_{\text{IR}} \oplus (2) \begin{array}{|c|} \hline \square \\ \hline \end{array}_{\text{IR}} \oplus \begin{array}{|c|c|} \hline \square & \square \\ \hline \end{array}_{\text{IR}}$,
- Level-3: $\boxed{8_s} \oplus \boxed{8_c} \oplus (2) \begin{array}{|c|} \hline \square \\ \hline \end{array}_{\text{IR}} \oplus (2) \begin{array}{|c|} \hline \square \\ \hline \end{array}_{\text{IR}} \oplus \begin{array}{|c|} \hline \boxed{8_s} \\ \hline \end{array}_{\text{IR}} \oplus \begin{array}{|c|} \hline \boxed{8_c} \\ \hline \end{array}_{\text{IR}}$,
- Level-4: $\cdot \oplus (2) \square_{\text{IR}} \oplus \begin{array}{|c|} \hline \square \\ \hline \end{array}_{\text{IR}} \oplus (3) \square_{\text{IR}} \oplus (2) \begin{array}{|c|c|} \hline \square & \square \\ \hline \end{array}_{\text{IR,C}} \oplus (2) \begin{array}{|c|c|} \hline \square & \square \\ \hline \end{array}_{\text{IR,S}}$
 $\oplus (2) \begin{array}{|c|} \hline \square \\ \hline \end{array}_{\text{IR}} \oplus (2) \begin{array}{|c|c|} \hline \square & \square \\ \hline \end{array}_{\text{IR}} \oplus \begin{array}{|c|c|} \hline \square & \square \\ \hline \end{array}_{\text{IR,C}} \oplus \begin{array}{|c|c|} \hline \square & \square \\ \hline \end{array}_{\text{IR,S}} \oplus \begin{array}{|c|c|} \hline \square & \square \\ \hline \end{array}_{\text{IR}} \oplus \begin{array}{|c|c|} \hline \square & \square \\ \hline \end{array}_{\text{IR}}$,
- Level-5: $(2) \boxed{8_s} \oplus (2) \boxed{8_c} \oplus (4) \begin{array}{|c|} \hline \square \\ \hline \end{array}_{\text{IR}} \oplus (4) \begin{array}{|c|} \hline \square \\ \hline \end{array}_{\text{IR}} \oplus \begin{array}{|c|} \hline \boxed{8_s} \\ \hline \end{array}_{\text{IR,S}} \oplus \begin{array}{|c|} \hline \boxed{8_c} \\ \hline \end{array}_{\text{IR,C}}$

4.4 Index structures and irreducible conditions of component fields in 8D minimal scalar superfield

In this section, we will translate the irreducible bosonic and mixed Young Tableaux into field variables. We follow the same $\{\}$ -indices notation as well as “|” to separate indices in YT with different heights and “,” to separate indices in YT with the same heights.

The vector index \underline{a} runs from 0 to 7. The $\{\}$ -indices, irreducible bosonic Young Tableaux, and Dynkin Labels are equivalent and have the one-to-one correspondence.

The general expression is as below in equations (4.7) and (4.8),

$$\{\underline{a}_1, \dots, \underline{a}_p \mid \underline{b}_1 \underline{c}_1, \dots, \underline{b}_q \underline{c}_q \mid \underline{d}_1 \underline{e}_1 \underline{f}_1, \dots, \underline{d}_r \underline{e}_r \underline{f}_r \mid \underline{g}_1 \underline{h}_1 \underline{i}_1 \underline{j}_1, \dots, \underline{g}_s \underline{h}_s \underline{i}_s \underline{j}_s\}^{S/C}$$

$\boxed{\underline{a}_1}$ $\boxed{\underline{a}_p}$ $\boxed{\underline{b}_1}$
 $\boxed{\underline{c}_1}$

$\boxed{\underline{b}_q}$
 $\boxed{\underline{c}_q}$

$\boxed{\underline{d}_1}$
 $\boxed{\underline{e}_1}$
 $\boxed{\underline{f}_1}$

$\boxed{\underline{d}_r}$
 $\boxed{\underline{e}_r}$
 $\boxed{\underline{f}_r}$

$\boxed{\underline{g}_1}$
 $\boxed{\underline{h}_1}$
 $\boxed{\underline{i}_1}$
 $\boxed{\underline{j}_1}$

$\boxed{\underline{g}_s}$
 $\boxed{\underline{h}_s}$
 $\boxed{\underline{i}_s}$
 $\boxed{\underline{j}_s}$

(4.7)

$[p, 0, 0, 0]$

$[0, q, 0, 0]$

$[0, 0, r, r]$

$[0, 0, 0, 2s]$ with superscript S
 $[0, 0, 2s, 0]$ with superscript C

where above we have “disassembled” the YT to show how each column is affiliated with each type of subscript structure. Below we have assembled all the columns into a proper YT.

\underline{g}_1	\dots	\underline{g}_s	\underline{d}_1	\dots	\underline{d}_r	\underline{b}_1	\dots	\underline{b}_q	\underline{a}_1	\dots	\underline{a}_p
\underline{h}_1	\dots	\underline{h}_s	\underline{e}_1	\dots	\underline{e}_r	\underline{c}_1	\dots	\underline{c}_q			
\underline{i}_1	\dots	\underline{i}_s	\underline{f}_1	\dots	\underline{f}_r						
\underline{j}_1	\dots	\underline{j}_s									

$[p, q, r, r + 2s]$ with subscript S
 $[p, q, r + 2s, r]$ with subscript C

(4.8)

As one moves from the YT’s shown in equation (4.7) to equation (4.8), it is clear the number of vertical boxes is tabulating the number of 1-forms, 2-forms, 3-forms, and 4-forms in the YT’s. These are the entries between the vertical | bars. These precisely correspond to the integers p , q , r , and s that appeared in Dynkin Labels. An example of the correspondence between the subscript conventions, the affiliated YT, and Dynkin Label is shown in (4.9).

$$\{\underline{a}_2, \underline{a}_3 \mid \underline{a}_1 \underline{b}_1 \underline{c}_1\} \equiv \begin{array}{|c|} \hline \underline{a}_1 \quad \underline{a}_2 \quad \underline{a}_3 \\ \hline \underline{b}_1 \\ \hline \underline{c}_1 \\ \hline \end{array} \equiv [2, 0, 1, 1]. \quad (4.9)$$

IR

In 8D, we have two types of spinor indices corresponding to $\boxed{8_s}$ and $\boxed{8_c}$ respectively. We define the field Ψ^α or $\Psi_{\dot{\alpha}}$ corresponds to $\boxed{8_s}$ and the field Ψ_α or $\Psi^{\dot{\alpha}}$ corresponds to $\boxed{8_c}$. The spinor indices α and $\dot{\alpha}$ run from 1 to 8.

The index structures as well as irreducible conditions of all bosonic and fermionic fields are identified below along with the level at which the fields occur in the adinkra of the scalar superfield.

- Level-0: $\Phi(x)$
- Level-1: $\Psi^\alpha(x)$, $\Psi_\alpha(x)$,
- Level-2: $\Phi_{\{a_1\}}(x)$, $(2)\Phi_{\{a_1b_1\}}(x)$, $\Phi_{\{a_1b_1c_1\}}(x)$,
- Level-3: $\Psi^\alpha(x)$, $\Psi_\alpha(x)$,
 - $(2)\Psi_{\{a_1\}\alpha}(x) : (\sigma^{a_1})^{\alpha\beta}\Psi_{\{a_1\}\alpha}(x) = 0$, $(2)\Psi_{\{a_1\}}^\alpha(x) : (\sigma^{a_1})_{\alpha\beta}\Psi_{\{a_1\}}^\alpha(x) = 0$,
 - $\Psi_{\{a_1b_1\}}^\alpha(x) : (\sigma^{a_1})_{\alpha\beta}\Psi_{\{a_1b_1\}}^\alpha(x) = 0$,
 - $\Psi_{\{a_1b_1\}\alpha}(x) : (\sigma^{a_1})^{\alpha\beta}\Psi_{\{a_1b_1\}\alpha}(x) = 0$,
- Level-4: $\Phi(x)$, $(2)\Phi_{\{a_1\}}(x)$, $\Phi_{\{a_1b_1\}}(x)$, $(3)\Phi_{\{a_1a_2\}}(x) : \eta^{a_1a_2}\Phi_{\{a_1a_2\}}(x) = 0$,
 - $(2)\Phi_{\{a_1b_1c_1d_1\}}^C(x) : \Phi_{\{a_1b_1c_1d_1\}}^C(x) = -\frac{1}{4!}\epsilon_{a_1b_1c_1d_1}{}^{e_1f_1g_1h_1}\Phi_{\{e_1f_1g_1h_1\}}^C(x)$,
 - $(2)\Phi_{\{a_1b_1c_1d_1\}}^S(x) : \Phi_{\{a_1b_1c_1d_1\}}^S(x) = \frac{1}{4!}\epsilon_{a_1b_1c_1d_1}{}^{e_1f_1g_1h_1}\Phi_{\{e_1f_1g_1h_1\}}^S(x)$,
 - $(2)\Phi_{\{a_1b_1c_1\}}(x)$, $(2)\Phi_{\{a_2|a_1b_1\}}(x) : \eta^{a_1a_2}\Phi_{\{a_2|a_1b_1\}}(x) = 0$,
 - $\Phi_{\{a_2|a_1b_1c_1d_1\}}^C(x) : \begin{cases} \eta^{a_1a_2}\Phi_{\{a_2|a_1b_1c_1d_1\}}^C(x) = 0, \\ \Phi_{\{a_2|a_1b_1c_1d_1\}}^C(x) = -\frac{1}{4!}\epsilon_{a_1b_1c_1d_1}{}^{e_1f_1g_1h_1}\Phi_{\{a_2|e_1f_1g_1h_1\}}^C(x). \end{cases}$
 - $\Phi_{\{a_2|a_1b_1c_1d_1\}}^S(x) : \begin{cases} \eta^{a_1a_2}\Phi_{\{a_2|a_1b_1c_1d_1\}}^S(x) = 0, \\ \Phi_{\{a_2|a_1b_1c_1d_1\}}^S(x) = \frac{1}{4!}\epsilon_{a_1b_1c_1d_1}{}^{e_1f_1g_1h_1}\Phi_{\{a_2|e_1f_1g_1h_1\}}^S(x). \end{cases}$
 - $\Phi_{\{a_1b_1a_2b_2\}}(x) : \begin{cases} \eta^{a_1a_2}\Phi_{\{a_1b_1a_2b_2\}}(x) = 0, \\ \eta^{a_1a_2}\eta^{b_1b_2}\Phi_{\{a_1b_1a_2b_2\}}(x) = 0, \end{cases}$
 - $\Phi_{\{a_2|a_1b_1c_1\}}(x) : \eta^{a_1a_2}\Phi_{\{a_2|a_1b_1c_1\}}(x) = 0$,
- Level-5: $(2)\Psi^\alpha(x)$, $(2)\Psi_\alpha(x)$,
 - $(4)\Psi_{\{a_1\}\alpha}(x) : (\sigma^{a_1})^{\alpha\beta}\Psi_{\{a_1\}\alpha}(x) = 0$, $(4)\Psi_{\{a_1\}}^\alpha(x) : (\sigma^{a_1})_{\alpha\beta}\Psi_{\{a_1\}}^\alpha(x) = 0$,
 - $\Psi_{\{a_1b_1c_1d_1\}}^S{}^\alpha(x) : \begin{cases} (\sigma^{a_1b_1})_\alpha{}^\delta\Psi_{\{a_1b_1c_1d_1\}}^S{}^\alpha(x) \equiv \psi_{\{c_1d_1\}}^\delta(x) = 0, \\ (\sigma^{c_1})_{\epsilon\delta}\psi_{\{c_1d_1\}}^\delta(x) \equiv \psi_{\{d_1\}\epsilon}(x) = 0, \\ (\sigma^{d_1})^{\tau\epsilon}\psi_{\{d_1\}\epsilon}(x) = 0, \end{cases}$

$$\Psi_{\{a_1 b_1 c_1 d_1\}^C \alpha}(x) : \begin{cases} (\sigma^{a_1 b_1})_{\delta} \Psi_{\{a_1 b_1 c_1 d_1\}^C \alpha}(x) \equiv \psi_{\{c_1 d_1\} \delta}(x) = 0, \\ (\sigma^{c_1})^{\epsilon \delta} \psi_{\{c_1 d_1\} \delta}(x) \equiv \psi_{\{d_1\} \epsilon}(x) = 0, \\ (\sigma^{d_1})_{\tau \epsilon} \psi_{\{d_1\} \epsilon}(x) = 0, \end{cases}$$

$$(2) \Psi_{\{a_1 b_1\} \alpha}(x) : (\sigma^{a_1})_{\alpha \beta} \Psi_{\{a_1 b_1\} \alpha}(x) = 0,$$

$$(2) \Psi_{\{a_1 b_1\} \alpha}(x) : (\sigma^{a_1})^{\alpha \beta} \Psi_{\{a_1 b_1\} \alpha}(x) = 0,$$

$$(2) \Psi_{\{a_1, a_2\} \alpha}(x) : \begin{cases} (\sigma^{a_2})_{\alpha \delta} \Psi_{\{a_1, a_2\} \alpha}(x) \equiv \psi_{\{a_1\} \delta}(x) = 0, \\ (\sigma^{a_1})^{\epsilon \delta} \psi_{\{a_1\} \delta}(x) = 0, \end{cases}$$

$$\Psi_{\{a_1 b_1 c_1 d_1\}^C \alpha}(x) : \begin{cases} (\sigma^{a_1 b_1 c_1})_{\alpha \delta} \Psi_{\{a_1 b_1 c_1 d_1\}^C \alpha}(x) \equiv \psi_{\{d_1\} \delta}(x) = 0, \\ (\sigma^{d_1})^{\epsilon \delta} \psi_{\{d_1\} \delta}(x) = 0, \end{cases}$$

$$(2) \Psi_{\{a_1, a_2\} \alpha}(x) : \begin{cases} (\sigma^{a_2})^{\alpha \delta} \Psi_{\{a_1, a_2\} \alpha}(x) \equiv \psi_{\{a_1\} \delta}(x) = 0, \\ (\sigma^{a_1})_{\epsilon \delta} \psi_{\{a_1\} \delta}(x) = 0, \end{cases}$$

$$\Psi_{\{a_1 b_1 c_1 d_1\}^S \alpha}(x) : \begin{cases} (\sigma^{a_1 b_1 c_1})^{\alpha \delta} \Psi_{\{a_1 b_1 c_1 d_1\}^S \alpha}(x) \equiv \psi_{\{d_1\} \delta}(x) = 0, \\ (\sigma^{d_1})_{\epsilon \delta} \psi_{\{d_1\} \delta}(x) = 0, \end{cases}$$

$$\Psi_{\{a_2 | a_1 b_1\} \alpha}(x) : \begin{cases} (\sigma^{b_1})^{\alpha \delta} \Psi_{\{a_2 | a_1 b_1\} \alpha}(x) \equiv \psi_{\{a_1, a_2\} \delta}(x) = 0, \\ (\sigma^{a_2})^{\alpha \delta} \Psi_{\{a_2 | a_1 b_1\} \alpha}(x) \equiv \psi_{\{a_1 b_1\} \delta}(x) = 0, \\ (\sigma^{b_1})_{\delta \epsilon} \psi_{\{a_1 b_1\} \delta}(x) = 0, \end{cases}$$

$$\Psi_{\{a_2 | a_1 b_1\} \alpha}(x) : \begin{cases} (\sigma^{b_1})_{\alpha \delta} \Psi_{\{a_2 | a_1 b_1\} \alpha}(x) \equiv \psi_{\{a_1, a_2\} \delta}(x) = 0, \\ (\sigma^{a_2})_{\alpha \delta} \Psi_{\{a_2 | a_1 b_1\} \alpha}(x) \equiv \psi_{\{a_1 b_1\} \delta}(x) = 0, \\ (\sigma^{b_1})^{\delta \epsilon} \psi_{\{a_1 b_1\} \delta}(x) = 0, \end{cases}$$

- Level-6: (3) $\Phi_{\{a_1\}}(x)$, (6) $\Phi_{\{a_1 b_1\}}(x)$, (2) $\Phi_{\{a_1, a_2\}}(x) : \eta^{a_1 a_2} \Phi_{\{a_1, a_2\}}(x) = 0$,

$$\Phi_{\{a_1 b_1 c_1 d_1\}^C}(x) : \Phi_{\{a_1 b_1 c_1 d_1\}^C}(x) = -\frac{1}{4!} \epsilon_{a_1 b_1 c_1 d_1} \epsilon_1 f_1 g_1 h_1 \Phi_{\{c_1 f_1 g_1 h_1\}^C}(x),$$

$$\Phi_{\{a_1 b_1 c_1 d_1\}^S}(x) : \Phi_{\{a_1 b_1 c_1 d_1\}^S}(x) = \frac{1}{4!} \epsilon_{a_1 b_1 c_1 d_1} \epsilon_1 f_1 g_1 h_1 \Phi_{\{c_1 f_1 g_1 h_1\}^S}(x),$$

$$(4) \Phi_{\{a_1 b_1 c_1\}}(x), \quad \Phi_{\{a_1, a_2, a_3\}}(x) : \eta^{a_1 a_2} \Phi_{\{a_1, a_2, a_3\}}(x) = 0,$$

$$(4) \Phi_{\{a_2 | a_1 b_1\}}(x) : \eta^{a_1 a_2} \Phi_{\{a_2 | a_1 b_1\}}(x) = 0,$$

$$(2) \Phi_{\{a_2 | a_1 b_1 c_1 d_1\}^C}(x) : \begin{cases} \eta^{a_1 a_2} \Phi_{\{a_2 | a_1 b_1 c_1 d_1\}^C}(x) = 0, \\ \Phi_{\{a_2 | a_1 b_1 c_1 d_1\}^C}(x) = -\frac{1}{4!} \epsilon_{a_1 b_1 c_1 d_1} \epsilon_1 f_1 g_1 h_1 \Phi_{\{a_2 | c_1 f_1 g_1 h_1\}^C}(x). \end{cases}$$

$$(2) \Phi_{\{a_2 | a_1 b_1 c_1 d_1\}^S}(x) : \begin{cases} \eta^{a_1 a_2} \Phi_{\{a_2 | a_1 b_1 c_1 d_1\}^S}(x) = 0, \\ \Phi_{\{a_2 | a_1 b_1 c_1 d_1\}^S}(x) = \frac{1}{4!} \epsilon_{a_1 b_1 c_1 d_1} \epsilon_1 f_1 g_1 h_1 \Phi_{\{a_2 | c_1 f_1 g_1 h_1\}^S}(x). \end{cases}$$

$$(4) \Phi_{\{a_2|a_1b_1c_1\}}(x) : \eta^{a_1a_2} \Phi_{\{a_2|a_1b_1c_1\}}(x) = 0,$$

$$(2) \Phi_{\{a_2,a_3|a_1b_1\}}(x) : \begin{cases} \eta^{a_2a_3} \Phi_{\{a_2,a_3|a_1b_1\}}(x) = 0, \\ \eta^{b_1a_3} \Phi_{\{a_2,a_3|a_1b_1\}}(x) = 0, \end{cases}$$

$$\Phi_{\{a_2b_2|a_1b_1c_1d_1\}}^C(x) : \begin{cases} \eta^{a_1a_2} \Phi_{\{a_2b_2|a_1b_1c_1d_1\}}^C(x) = 0, \\ \eta^{a_1a_2} \eta^{b_1b_2} \Phi_{\{a_2b_2|a_1b_1c_1d_1\}}^C(x) = 0, \\ \Phi_{\{a_2b_2|a_1b_1c_1d_1\}}^C(x) = -\frac{1}{4!} \epsilon_{a_1b_1c_1d_1} \frac{f_1g_1h_1i_1}{4!} \Phi_{\{a_2b_2|f_1g_1h_1i_1\}}^C(x). \end{cases}$$

$$\Phi_{\{a_2b_2|a_1b_1c_1d_1\}}^S(x) : \begin{cases} \eta^{a_1a_2} \Phi_{\{a_2b_2|a_1b_1c_1d_1\}}^S(x) = 0, \\ \eta^{a_1a_2} \eta^{b_1b_2} \Phi_{\{a_2b_2|a_1b_1c_1d_1\}}^S(x) = 0, \\ \Phi_{\{a_2b_2|a_1b_1c_1d_1\}}^S(x) = \frac{1}{4!} \epsilon_{a_1b_1c_1d_1} \frac{f_1g_1h_1i_1}{4!} \Phi_{\{a_2b_2|f_1g_1h_1i_1\}}^S(x). \end{cases}$$

$$\Phi_{\{a_2b_2|a_1b_1c_1\}}(x) : \begin{cases} \eta^{a_1a_2} \Phi_{\{a_2b_2|a_1b_1c_1\}}(x) = 0, \\ \eta^{a_1a_2} \eta^{b_1b_2} \Phi_{\{a_2b_2|a_1b_1c_1\}}(x) = 0, \end{cases}$$

$$\Phi_{\{a_2,a_3|a_1b_1c_1\}}(x) : \begin{cases} \eta^{a_2a_3} \Phi_{\{a_2,a_3|a_1b_1c_1\}}(x) = 0, \\ \eta^{c_1a_3} \Phi_{\{a_2,a_3|a_1b_1c_1\}}(x) = 0, \end{cases}$$

- Level-7: (4) $\Psi^\alpha(x)$, (4) $\Psi_\alpha(x)$,

$$(5) \Psi_{\{a_1\}}^\alpha(x) : (\sigma^{a_1})^{\alpha\beta} \Psi_{\{a_1\}}^\alpha(x) = 0, \quad (5) \Psi_{\{a_1\}}^\alpha(x) : (\sigma^{a_1})_{\alpha\beta} \Psi_{\{a_1\}}^\alpha(x) = 0,$$

$$(4) \Psi_{\{a_1b_1\}}^\alpha(x) : (\sigma^{a_1})_{\alpha\beta} \Psi_{\{a_1b_1\}}^\alpha(x) = 0,$$

$$(4) \Psi_{\{a_1b_1\}}^\alpha(x) : (\sigma^{a_1})^{\alpha\beta} \Psi_{\{a_1b_1\}}^\alpha(x) = 0,$$

$$(3) \Psi_{\{a_1,a_2\}}^\alpha(x) : \begin{cases} (\sigma^{a_2})_{\alpha\delta} \Psi_{\{a_1,a_2\}}^\alpha(x) \equiv \psi_{\{a_1\}}^\delta(x) = 0, \\ (\sigma^{a_1})^{\epsilon\delta} \psi_{\{a_1\}}^\delta(x) = 0, \end{cases}$$

$$(2) \Psi_{\{a_1b_1c_1d_1\}}^C(x) : \begin{cases} (\sigma^{a_1b_1c_1})_{\alpha\delta} \Psi_{\{a_1b_1c_1d_1\}}^C(x) \equiv \psi_{\{d_1\}}^\delta(x) = 0, \\ (\sigma^{d_1})^{\epsilon\delta} \psi_{\{d_1\}}^\delta(x) = 0, \end{cases}$$

$$(3) \Psi_{\{a_1,a_2\}}^\alpha(x) : \begin{cases} (\sigma^{a_2})^{\alpha\delta} \Psi_{\{a_1,a_2\}}^\alpha(x) \equiv \psi_{\{a_1\}}^\delta(x) = 0, \\ (\sigma^{a_1})_{\epsilon\delta} \psi_{\{a_1\}}^\delta(x) = 0, \end{cases}$$

$$(2) \Psi_{\{a_1b_1c_1d_1\}}^S(x) : \begin{cases} (\sigma^{a_1b_1c_1})^{\alpha\delta} \Psi_{\{a_1b_1c_1d_1\}}^S(x) \equiv \psi_{\{d_1\}}^\delta(x) = 0, \\ (\sigma^{d_1})_{\epsilon\delta} \psi_{\{d_1\}}^\delta(x) = 0, \end{cases}$$

$$\Psi_{\{a_1,a_2,a_3\}}^\alpha(x) : \begin{cases} (\sigma^{a_3})^{\alpha\delta} \Psi_{\{a_1,a_2,a_3\}}^\alpha(x) \equiv \psi_{\{a_1,a_2\}}^\delta(x) = 0, \\ (\sigma^{a_2})_{\epsilon\delta} \psi_{\{a_1,a_2\}}^\delta(x) \equiv \psi_{\{a_1\}}^\epsilon(x) = 0, \\ (\sigma^{a_1})^{\tau\epsilon} \psi_{\{a_1\}}^\epsilon(x) = 0. \end{cases}$$

$$\Psi_{\{a_1, a_2, a_3\}}^\alpha(x) : \begin{cases} (\sigma^{a_3})_{\alpha\delta} \Psi_{\{a_1, a_2, a_3\}}^\alpha(x) \equiv \psi_{\{a_1, a_2\}}^\delta(x) = 0, \\ (\sigma^{a_2})^{\epsilon\delta} \psi_{\{a_1, a_2\}}^\delta(x) \equiv \psi_{\{a_1\}}^\epsilon(x) = 0, \\ (\sigma^{a_1})_{\tau\epsilon} \psi_{\{a_1\}}^\epsilon(x) = 0. \end{cases}$$

$$(2) \Psi_{\{a_2|a_1b_1\}}^\alpha(x) : \begin{cases} (\sigma^{b_1})^{\alpha\delta} \Psi_{\{a_2|a_1b_1\}}^\alpha(x) \equiv \psi_{\{a_1, a_2\}}^\delta(x) = 0, \\ (\sigma^{a_2})^{\alpha\delta} \Psi_{\{a_2|a_1b_1\}}^\alpha(x) \equiv \psi_{\{a_1b_1\}}^\delta(x) = 0, \\ (\sigma^{b_1})_{\delta\epsilon} \psi_{\{a_1b_1\}}^\delta(x) = 0, \end{cases}$$

$$(2) \Psi_{\{a_2|a_1b_1\}}^\alpha(x) : \begin{cases} (\sigma^{b_1})_{\alpha\delta} \Psi_{\{a_2|a_1b_1\}}^\alpha(x) \equiv \psi_{\{a_1, a_2\}}^\delta(x) = 0, \\ (\sigma^{a_2})_{\alpha\delta} \Psi_{\{a_2|a_1b_1\}}^\alpha(x) \equiv \psi_{\{a_1b_1\}}^\delta(x) = 0, \\ (\sigma^{b_1})^{\delta\epsilon} \psi_{\{a_1b_1\}}^\delta(x) = 0, \end{cases}$$

$$\Psi_{\{a_2|a_1b_1c_1d_1\}}^{S\alpha}(x) : \begin{cases} (\sigma^{a_2})^{\alpha\delta} \Psi_{\{a_2|a_1b_1c_1d_1\}}^{S\alpha}(x) \equiv \psi_{\{a_1b_1c_1d_1\}}^{S\delta}(x) = 0, \\ (\sigma^{b_1c_1d_1})^{\alpha\delta} \Psi_{\{a_2|a_1b_1c_1d_1\}}^{S\alpha}(x) \equiv \psi_{\{a_1, a_2\}}^\delta(x) = 0, \\ (\sigma^{a_2})_{\delta\epsilon} \psi_{\{a_1, a_2\}}^\delta(x) = 0, \end{cases}$$

$$\Psi_{\{a_2|a_1b_1c_1d_1\}}^{C\alpha}(x) : \begin{cases} (\sigma^{a_2})_{\alpha\delta} \Psi_{\{a_2|a_1b_1c_1d_1\}}^{C\alpha}(x) \equiv \psi_{\{a_1b_1c_1d_1\}}^{C\delta}(x) = 0, \\ (\sigma^{b_1c_1d_1})_{\alpha\delta} \Psi_{\{a_2|a_1b_1c_1d_1\}}^{C\alpha}(x) \equiv \psi_{\{a_1, a_2\}}^\delta(x) = 0, \\ (\sigma^{a_2})^{\delta\epsilon} \psi_{\{a_1, a_2\}}^\delta(x) = 0, \end{cases}$$

- Level-8: (5) $\Phi(x)$, (4) $\Phi_{\{a_1\}}(x)$, (3) $\Phi_{\{a_1b_1\}}(x)$, (4) $\Phi_{\{a_1, a_2\}}(x) : \eta^{a_1a_2} \Phi_{\{a_1, a_2\}}(x) = 0$,

$$(3) \Phi_{\{a_1b_1c_1d_1\}}^{C}(x) : \Phi_{\{a_1b_1c_1d_1\}}^{C}(x) = -\frac{1}{4!} \epsilon_{a_1b_1c_1d_1} \epsilon_1 f_1 g_1 h_1 \Phi_{\{\epsilon_1 f_1 g_1 h_1\}}^{C}(x),$$

$$(3) \Phi_{\{a_1b_1c_1d_1\}}^{S}(x) : \Phi_{\{a_1b_1c_1d_1\}}^{S}(x) = \frac{1}{4!} \epsilon_{a_1b_1c_1d_1} \epsilon_1 f_1 g_1 h_1 \Phi_{\{\epsilon_1 f_1 g_1 h_1\}}^{S}(x),$$

$$(6) \Phi_{\{a_1b_1c_1\}}(x), \quad (2) \Phi_{\{a_1, a_2, a_3\}}(x) : \eta^{a_1a_2} \Phi_{\{a_1, a_2, a_3\}}(x) = 0,$$

$$(4) \Phi_{\{a_2|a_1b_1\}}(x) : \eta^{a_1a_2} \Phi_{\{a_2|a_1b_1\}}(x) = 0,$$

$$(2) \Phi_{\{a_2|a_1b_1c_1d_1\}}^{C}(x) : \begin{cases} \eta^{a_1a_2} \Phi_{\{a_2|a_1b_1c_1d_1\}}^{C}(x) = 0, \\ \Phi_{\{a_2|a_1b_1c_1d_1\}}^{C}(x) = -\frac{1}{4!} \epsilon_{a_1b_1c_1d_1} \epsilon_1 f_1 g_1 h_1 \Phi_{\{a_2|\epsilon_1 f_1 g_1 h_1\}}^{C}(x). \end{cases}$$

$$(2) \Phi_{\{a_2|a_1b_1c_1d_1\}}^{S}(x) : \begin{cases} \eta^{a_1a_2} \Phi_{\{a_2|a_1b_1c_1d_1\}}^{S}(x) = 0, \\ \Phi_{\{a_2|a_1b_1c_1d_1\}}^{S}(x) = \frac{1}{4!} \epsilon_{a_1b_1c_1d_1} \epsilon_1 f_1 g_1 h_1 \Phi_{\{a_2|\epsilon_1 f_1 g_1 h_1\}}^{S}(x). \end{cases}$$

$$\Phi_{\{a_1, a_2, a_3, a_4\}}(x) : \begin{cases} \eta^{a_1a_2} \Phi_{\{a_1, a_2, a_3, a_4\}}(x) = 0, \\ \eta^{a_1a_2} \eta^{a_3a_4} \Phi_{\{a_1, a_2, a_3, a_4\}}(x) = 0, \end{cases}$$

$$(3) \Phi_{\{a_1b_1, a_2b_2\}}(x) : \begin{cases} \eta^{a_1a_2} \Phi_{\{a_1b_1, a_2b_2\}}(x) = 0, \\ \eta^{a_1a_2} \eta^{b_1b_2} \Phi_{\{a_1b_1, a_2b_2\}}(x) = 0, \end{cases}$$

$$\begin{aligned}
 (5) \Phi_{\{a_2|a_1b_1c_1\}}(x) &: \eta^{a_1a_2}\Phi_{\{a_2|a_1b_1c_1\}}(x) = 0, \\
 \Phi_{\{a_2,a_3|a_1b_1\}}(x) &: \begin{cases} \eta^{a_2a_3}\Phi_{\{a_2,a_3|a_1b_1\}}(x) = 0, \\ \eta^{b_1a_3}\Phi_{\{a_2,a_3|a_1b_1\}}(x) = 0, \end{cases} \\
 (2) \Phi_{\{a_2b_2|a_1b_1c_1\}}(x) &: \begin{cases} \eta^{a_1a_2}\Phi_{\{a_2b_2|a_1b_1c_1\}}(x) = 0, \\ \eta^{a_1a_2}\eta^{b_1b_2}\Phi_{\{a_2b_2|a_1b_1c_1\}}(x) = 0, \end{cases} \\
 \Phi_{\{a_2,a_3|a_1b_1c_1d_1\}}^C(x) &: \begin{cases} \eta^{a_2a_3}\Phi_{\{a_2,a_3|a_1b_1c_1d_1\}}^C(x) = 0, \\ \eta^{d_1a_3}\Phi_{\{a_2,a_3|a_1b_1c_1d_1\}}^C(x) = 0, \\ \Phi_{\{a_2,a_3|a_1b_1c_1d_1\}}^C(x) = -\frac{1}{4!}\epsilon_{a_1b_1c_1d_1}{}^{\epsilon_1f_1g_1h_1}\Phi_{\{a_2,a_3|e_1f_1g_1h_1\}}^C(x), \end{cases} \\
 \Phi_{\{a_2,a_3|a_1b_1c_1d_1\}}^S(x) &: \begin{cases} \eta^{a_2a_3}\Phi_{\{a_2,a_3|a_1b_1c_1d_1\}}^S(x) = 0, \\ \eta^{d_1a_3}\Phi_{\{a_2,a_3|a_1b_1c_1d_1\}}^S(x) = 0, \\ \Phi_{\{a_2,a_3|a_1b_1c_1d_1\}}^S(x) = \frac{1}{4!}\epsilon_{a_1b_1c_1d_1}{}^{\epsilon_1f_1g_1h_1}\Phi_{\{a_2,a_3|e_1f_1g_1h_1\}}^S(x), \end{cases} \\
 \Phi_{\{a_1b_1c_1,a_2b_2c_2\}}(x) &: \begin{cases} \eta^{a_1a_2}\Phi_{\{a_1b_1c_1,a_2b_2c_2\}}(x) = 0, \\ \eta^{a_1a_2}\eta^{b_1b_2}\Phi_{\{a_1b_1c_1,a_2b_2c_2\}}(x) = 0, \\ \eta^{a_1a_2}\eta^{b_1b_2}\eta^{c_1c_2}\Phi_{\{a_1b_1c_1,a_2b_2c_2\}}(x) = 0, \end{cases} \\
 (2) \Phi_{\{a_2,a_3|a_1b_1c_1\}}(x) &: \begin{cases} \eta^{a_2a_3}\Phi_{\{a_2,a_3|a_1b_1c_1\}}(x) = 0, \\ \eta^{c_1a_3}\Phi_{\{a_2,a_3|a_1b_1c_1\}}(x) = 0, \end{cases}
 \end{aligned}$$

Level-9 to Level-16 have exactly the same expressions as Level-7 to Level-0.

4.5 (1, 0) multiplet decompositions

Since in eight spacetime dimensions, we actually have chiral spinors corresponding to $[0, 0, 0, 1]$ representation. So in principle, we can study the component decompositions in the (1, 0) supermultiplet, namely only consider the $[0, 0, 0, 1]$ spinor in the θ -expansion. The dimension of $[0, 0, 0, 1]$ equals eight implies the (1, 0) decomposition has 9 levels in total. Level- n in this case is the antisymmetric product decomposition of n $[0, 0, 0, 1]$'s, which can be directly calculated by Plethysm function as discussed in [2, 10]. Branching rules of $\mathfrak{su}(8) \supset \mathfrak{so}(8)$ also give the same results. The antisymmetric product decomposition of $([0, 0, 0, 1])^{\wedge n}$ is equivalent to the branching rule of $[0, \dots, 1, \dots, 0]$ irrep in $\mathfrak{su}(8)$ to $\mathfrak{so}(8)$, where the n -th integer is 1 and all others are zero. The projection matrix of $\mathfrak{su}(8) \supset \mathfrak{so}(8)$ will be discussed in appendix B.3.

The (1, 0) decomposition results are as below. They are the subset of the complete decomposition results.

- Level-0: $[0, 0, 0, 0]$ ($\{1\}$)
- Level-1: $[0, 0, 0, 1]$ ($\{8_s\}$)

- Level-2: $[0, 1, 0, 0]$ ($\{28\}$)
- Level-3: $[1, 0, 1, 0]$ ($\{56_s\}$)
- Level-4: $[0, 0, 2, 0]$ ($\{35_c\}$) \oplus $[2, 0, 0, 0]$ ($\{35_v\}$)
- Level-5: $[1, 0, 1, 0]$ ($\{56_s\}$)
- Level-6: $[0, 1, 0, 0]$ ($\{28\}$)
- Level-7: $[0, 0, 0, 1]$ ($\{8_s\}$)
- Level-8: $[0, 0, 0, 0]$ ($\{1\}$)

Starting from the $(1, 0)$ multiplet decomposition, we can reproduce the scalar superfield decomposition using similar ideas when we constructed 10D Type IIA scalar superfield from 10D Type I superfield in [1]. Basically we can label spinors as θ^α and $\theta^{\dot{\alpha}}$ corresponding to $[0, 0, 0, 1]$ and $[0, 0, 1, 0]$ respectively. Then expand the scalar superfield only with respect to $\theta^{\dot{\alpha}}$ first where the accompanying component fields are actually $(1, 0)$ superfields. Namely,

$$\begin{aligned}
 \mathcal{V}(x, \theta^\alpha, \theta^{\dot{\alpha}}) &= \mathcal{V}(x, \theta^\alpha) + \theta^{\dot{\alpha}} \mathcal{V}_{\dot{\alpha}}(x, \theta^\alpha) + \theta^{\dot{\alpha}} \theta^{\dot{\beta}} \mathcal{V}_{\dot{\alpha}\dot{\beta}}(x, \theta^\alpha) + \dots \\
 &= \mathcal{V}^{(0)}(x) + \theta^\alpha \mathcal{V}_\alpha^{(1)}(x) + \theta^\alpha \theta^\beta \mathcal{V}_{\alpha\beta}^{(2)}(x) + \dots \\
 &\quad + \theta^{\dot{\alpha}} \left[\mathcal{V}_{\dot{\alpha}}^{(0)}(x) + \theta^\alpha \mathcal{V}_{\dot{\alpha}\alpha}^{(1)}(x) + \theta^\alpha \theta^\beta \mathcal{V}_{\dot{\alpha}\alpha\beta}^{(2)}(x) + \dots \right] \\
 &\quad + \theta^{\dot{\alpha}} \theta^{\dot{\beta}} \left[\mathcal{V}_{\dot{\alpha}\dot{\beta}}^{(0)}(x) + \theta^\alpha \mathcal{V}_{\dot{\alpha}\dot{\beta}\alpha}^{(1)}(x) + \theta^\alpha \theta^\beta \mathcal{V}_{\dot{\alpha}\dot{\beta}\alpha\beta}^{(2)}(x) + \dots \right] \\
 &\quad + \dots
 \end{aligned} \tag{4.10}$$

which implies that for example, Level-2 in the scalar superfield decomposition is nothing but $\{8_s\} \wedge \{8_s\} \oplus \{8_c\} \wedge \{8_c\} \oplus \{8_s\} \otimes \{8_c\} = \{8_v\} \oplus (2)\{28\} \oplus \{56_v\}$.

Last but not least, we can draw the adynkra and adinkra diagrams corresponding to the $(1, 0)$ multiplet, which are figures 5 and 6.

5 7D minimal scalar superfield decomposition

5.1 Component decomposition results

The 7D minimal superfield component decomposition results by Dynkin Labels are given below.

- Level-0: $[0, 0, 0]$
- Level-1: $(2)[0, 0, 1]$
- Level-2: $[0, 0, 0] \oplus (3)[1, 0, 0] \oplus (3)[0, 1, 0] \oplus [0, 0, 2]$
- Level-3: $(6)[0, 0, 1] \oplus (6)[1, 0, 1] \oplus (2)[0, 1, 1]$

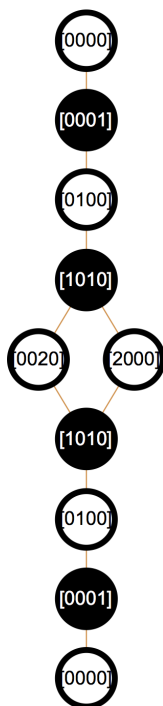

Figure 5. Adynkra Diagram for 8D (1,0) Multiplet.

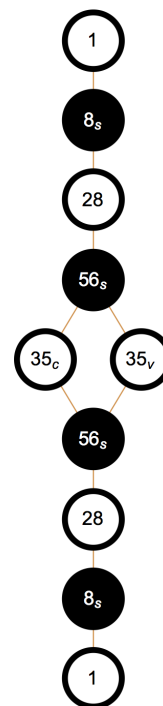

Figure 6. Adinkra Diagram for 8D (1,0) Multiplet.

- Level-4: $(6)[0, 0, 0] \oplus (8)[1, 0, 0] \oplus (6)[0, 1, 0] \oplus (6)[2, 0, 0] \oplus (9)[0, 0, 2] \oplus (4)[1, 1, 0] \oplus [0, 2, 0] \oplus (3)[1, 0, 2]$
- Level-5: $(16)[0, 0, 1] \oplus (18)[1, 0, 1] \oplus (8)[0, 1, 1] \oplus (4)[0, 0, 3] \oplus (6)[2, 0, 1] \oplus (2)[1, 1, 1]$
- Level-6: $(6)[0, 0, 0] \oplus (18)[1, 0, 0] \oplus (21)[0, 1, 0] \oplus (9)[2, 0, 0] \oplus (15)[0, 0, 2] \oplus (3)[3, 0, 0] \oplus (12)[1, 1, 0] \oplus [0, 2, 0] \oplus (12)[1, 0, 2] \oplus (3)[2, 1, 0] \oplus (3)[0, 1, 2] \oplus [2, 0, 2]$
- Level-7: $(26)[0, 0, 1] \oplus (30)[1, 0, 1] \oplus (18)[0, 1, 1] \oplus (6)[0, 0, 3] \oplus (12)[2, 0, 1] \oplus (2)[3, 0, 1] \oplus (6)[1, 1, 1] \oplus (2)[1, 0, 3]$
- Level-8: $(16)[0, 0, 0] \oplus (19)[1, 0, 0] \oplus (21)[0, 1, 0] \oplus (15)[2, 0, 0] \oplus (25)[0, 0, 2] \oplus (4)[3, 0, 0] \oplus (17)[1, 1, 0] \oplus (6)[0, 2, 0] \oplus [4, 0, 0] \oplus (15)[1, 0, 2] \oplus [0, 0, 4] \oplus (3)[2, 1, 0] \oplus (3)[0, 1, 2] \oplus (4)[2, 0, 2]$
- Level-9: $(26)[0, 0, 1] \oplus (30)[1, 0, 1] \oplus (18)[0, 1, 1] \oplus (6)[0, 0, 3] \oplus (12)[2, 0, 1] \oplus (2)[3, 0, 1] \oplus (6)[1, 1, 1] \oplus (2)[1, 0, 3]$
- Level-10: $(6)[0, 0, 0] \oplus (18)[1, 0, 0] \oplus (21)[0, 1, 0] \oplus (9)[2, 0, 0] \oplus (15)[0, 0, 2] \oplus (3)[3, 0, 0] \oplus (12)[1, 1, 0] \oplus [0, 2, 0] \oplus (12)[1, 0, 2] \oplus (3)[2, 1, 0] \oplus (3)[0, 1, 2] \oplus [2, 0, 2]$
- Level-11: $(16)[0, 0, 1] \oplus (18)[1, 0, 1] \oplus (8)[0, 1, 1] \oplus (4)[0, 0, 3] \oplus (6)[2, 0, 1] \oplus (2)[1, 1, 1]$
- Level-12: $(6)[0, 0, 0] \oplus (8)[1, 0, 0] \oplus (6)[0, 1, 0] \oplus (6)[2, 0, 0] \oplus (9)[0, 0, 2] \oplus (4)[1, 1, 0] \oplus [0, 2, 0] \oplus (3)[1, 0, 2]$

- Level-13: $(6)[0, 0, 1] \oplus (6)[1, 0, 1] \oplus (2)[0, 1, 1]$
- Level-14: $[0, 0, 0] \oplus (3)[1, 0, 0] \oplus (3)[0, 1, 0] \oplus [0, 0, 2]$
- Level-15: $(2)[0, 0, 1]$
- Level-16: $[0, 0, 0]$

Here are the component decomposition results by dimensions.

- Level-0: $\{1\}$
- Level-1: $(2)\{8\}$
- Level-2: $\{1\} \oplus (3)\{7\} \oplus (3)\{21\} \oplus \{35\}$
- Level-3: $(6)\{8\} \oplus (6)\{48\} \oplus (2)\{112\}$
- Level-4: $(6)\{1\} \oplus (8)\{7\} \oplus (6)\{21\} \oplus (6)\{27\} \oplus (9)\{35\} \oplus (4)\{105\} \oplus \{168'\} \oplus (3)\{189\}$
- Level-5: $(16)\{8\} \oplus (18)\{48\} \oplus (8)\{112\} \oplus (4)\{112'\} \oplus (6)\{168\} \oplus (2)\{512\}$
- Level-6: $(6)\{1\} \oplus (18)\{7\} \oplus (21)\{21\} \oplus (9)\{27\} \oplus (15)\{35\} \oplus (3)\{77\} \oplus (12)\{105\} \oplus \{168'\} \oplus (12)\{189\} \oplus (3)\{330\} \oplus (3)\{378\} \oplus \{616\}$
- Level-7: $(26)\{8\} \oplus (30)\{48\} \oplus (18)\{112\} \oplus (6)\{112'\} \oplus (12)\{168\} \oplus (2)\{448\} \oplus (6)\{512\} \oplus (2)\{560\}$
- Level-8: $(16)\{1\} \oplus (19)\{7\} \oplus (21)\{21\} \oplus (15)\{27\} \oplus (25)\{35\} \oplus (4)\{77\} \oplus (17)\{105\} \oplus (6)\{168'\} \oplus \{182\} \oplus (15)\{189\} \oplus \{294\} \oplus (3)\{330\} \oplus (3)\{378\} \oplus (4)\{616\}$
- Level-9: $(26)\{8\} \oplus (30)\{48\} \oplus (18)\{112\} \oplus (6)\{112'\} \oplus (12)\{168\} \oplus (2)\{448\} \oplus (6)\{512\} \oplus (2)\{560\}$
- Level-10: $(6)\{1\} \oplus (18)\{7\} \oplus (21)\{21\} \oplus (9)\{27\} \oplus (15)\{35\} \oplus (3)\{77\} \oplus (12)\{105\} \oplus \{168'\} \oplus (12)\{189\} \oplus (3)\{330\} \oplus (3)\{378\} \oplus \{616\}$
- Level-11: $(16)\{8\} \oplus (18)\{48\} \oplus (8)\{112\} \oplus (4)\{112'\} \oplus (6)\{168\} \oplus (2)\{512\}$
- Level-12: $(6)\{1\} \oplus (8)\{7\} \oplus (6)\{21\} \oplus (6)\{27\} \oplus (9)\{35\} \oplus (4)\{105\} \oplus \{168'\} \oplus (3)\{189\}$
- Level-13: $(6)\{8\} \oplus (6)\{48\} \oplus (2)\{112\}$
- Level-14: $\{1\} \oplus (3)\{7\} \oplus (3)\{21\} \oplus \{35\}$
- Level-15: $(2)\{8\}$
- Level-16: $\{1\}$

5.2 7D Minimal Adinkra Diagram

The Adynkra and Adinkra diagrams for 7D minimal scalar superfield (up to Level-2) are shown in figures 7 and 8.

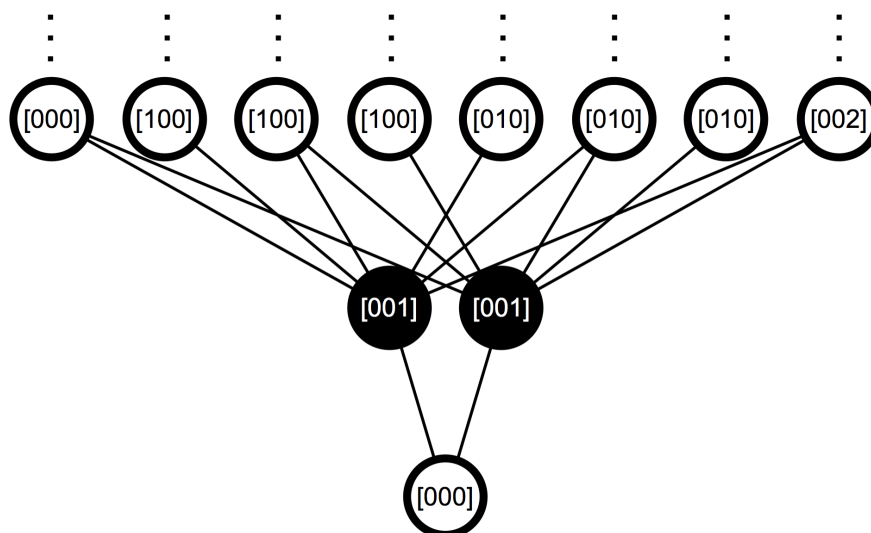

Figure 7. Adynkra Diagram for 7D minimal scalar superfield.

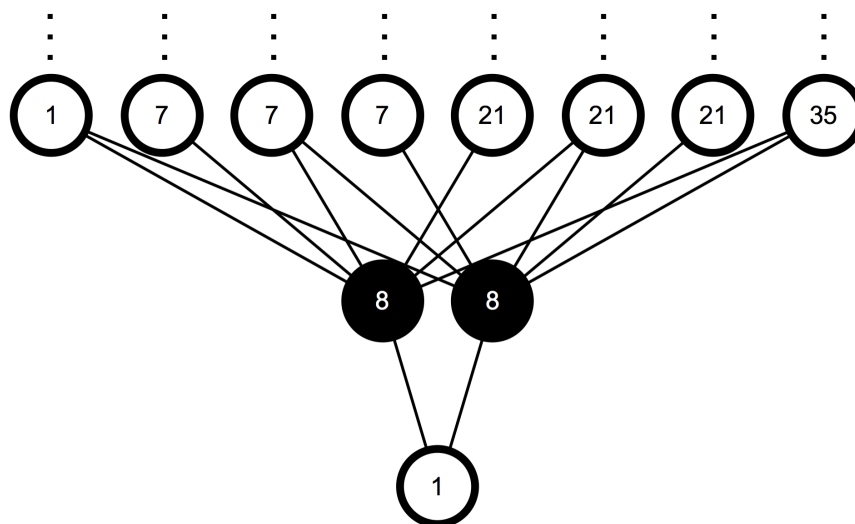

Figure 8. Adinkra Diagram for 7D minimal scalar superfield.

5.3 Young Tableaux descriptions of component fields in 7D minimal scalar superfield

Consider the projection matrix for $\mathfrak{su}(7) \supset \mathfrak{so}(7)$ [9],

$$P_{\mathfrak{su}(7) \supset \mathfrak{so}(7)} = \begin{pmatrix} 1 & 0 & 0 & 0 & 0 & 1 \\ 0 & 1 & 0 & 0 & 1 & 0 \\ 0 & 0 & 2 & 2 & 0 & 0 \end{pmatrix}. \tag{5.1}$$

The highest weight of a specified irrep of $\mathfrak{su}(7)$ is a row vector $[p_1, p_2, p_3, p_4, p_5, p_6]$, where p_1 to p_6 are non-negative integers. Since the $\mathfrak{su}(7)$ YT with n vertical boxes is the conjugate of the one with $7 - n$ vertical boxes, we only need to consider the $p_4 = p_5 = p_6 = 0$ case.

Starting from the weight vector $[p_1, p_2, p_3, 0, 0, 0]$ in $\mathfrak{su}(7)$, we define its projected weight vector $[p_1, p_2, 2p_3]$ in $\mathfrak{so}(7)$ as the Dynkin Label of the corresponding irreducible bosonic Young Tableau.

$$[p_1, p_2, 2p_3] = [p_1, p_2, p_3, 0, 0, 0] P_{\mathfrak{su}(7) \supset \mathfrak{so}(7)}^T. \tag{5.2}$$

Then look at the congruence classes of a representation with Dynkin Label $[a, b, c]$ in $\mathfrak{so}(7)$,

$$C_c(R) := c \pmod{2}. \tag{5.3}$$

$C_c(R)$ classifies the bosonic irreps and spinorial irreps: $C_c(R) = 0$ is bosonic and $C_c(R) = 1$ is spinorial. Consequently, a bosonic irrep satisfies $c = 0 \pmod{2}$.

Therefore, given an irreducible bosonic Young Tableau with p_1 columns of one box, p_2 columns of two vertical boxes, and p_3 columns of three vertical boxes, the Dynkin Label of its corresponding bosonic irrep is $[p_1, p_2, 2p_3]$. Reversely, given a bosonic irrep with Dynkin Label $[a, b, c]$, its corresponding irreducible bosonic Young Tableau is composed of a columns of one box, b columns of two vertical boxes, and $c/2$ columns of three vertical boxes.

The simplest examples, also the fundamental building blocks of a BYT, are given below.

$$\begin{array}{|c|} \hline \square \\ \hline \end{array}_{\text{IR}} \equiv [1, 0, 0], \quad \begin{array}{|c|} \hline \square \\ \hline \square \\ \hline \end{array}_{\text{IR}} \equiv [0, 1, 0], \quad \begin{array}{|c|} \hline \square \\ \hline \square \\ \hline \square \\ \hline \end{array}_{\text{IR}} \equiv [0, 0, 2]. \tag{5.4}$$

For spinorial irreps, the basic SYT is given by

$$\begin{array}{|c|} \hline \square \\ \hline \end{array} \equiv [0, 0, 1]. \tag{5.5}$$

We could translate the Dynkin Label of any spinorial irrep to a mixed YT (which contains a BYT part and a basic SYT above) with irreducible conditions by applying the same idea discussed in chapter five in [3].

Putting together the columns in (5.4) and (5.5) corresponds to adding their Dynkin Labels.

In summary, the irreducible Young Tableau descriptions of the 7D minimal scalar superfield decomposition is presented below.

$$\mathcal{V} = \left\{ \begin{array}{l}
 \text{Level-0} \quad \cdot, \\
 \text{Level-1} \quad (2) \boxed{8}, \\
 \text{Level-2} \quad \cdot \oplus (3) \square_{\text{IR}} \oplus (3) \begin{array}{|c|} \hline \square \\ \hline \end{array}_{\text{IR}} \oplus \begin{array}{|c|} \hline \square \\ \hline \square \\ \hline \end{array}_{\text{IR}}, \\
 \text{Level-3} \quad (6) \boxed{8} \oplus (6) \square_{\text{IR}} \oplus (2) \begin{array}{|c|} \hline \boxed{8} \\ \hline \end{array}_{\text{IR}}, \\
 \text{Level-4} \quad (6) \cdot \oplus (8) \square_{\text{IR}} \oplus (6) \begin{array}{|c|} \hline \square \\ \hline \end{array}_{\text{IR}} \oplus (6) \square_{\text{IR}} \oplus (9) \begin{array}{|c|} \hline \square \\ \hline \square \\ \hline \end{array}_{\text{IR}} \\
 \oplus (4) \begin{array}{|c|} \hline \square \\ \hline \square \\ \hline \end{array}_{\text{IR}} \oplus \begin{array}{|c|} \hline \square \\ \hline \square \\ \hline \end{array}_{\text{IR}} \oplus (3) \begin{array}{|c|} \hline \square \\ \hline \square \\ \hline \end{array}_{\text{IR}}, \\
 \text{Level-5} \quad (16) \boxed{8} \oplus (18) \square_{\text{IR}} \oplus (8) \begin{array}{|c|} \hline \boxed{8} \\ \hline \end{array}_{\text{IR}} \oplus (4) \begin{array}{|c|} \hline \boxed{8} \\ \hline \end{array}_{\text{IR}} \oplus (6) \square_{\text{IR}} \oplus (2) \begin{array}{|c|} \hline \square \\ \hline \square \\ \hline \end{array}_{\text{IR}}, \\
 \text{Level-6} \quad (6) \cdot \oplus (18) \square_{\text{IR}} \oplus (21) \begin{array}{|c|} \hline \square \\ \hline \end{array}_{\text{IR}} \oplus (9) \square_{\text{IR}} \oplus (15) \begin{array}{|c|} \hline \square \\ \hline \square \\ \hline \end{array}_{\text{IR}} \oplus (3) \square_{\text{IR}} \\
 \oplus (12) \begin{array}{|c|} \hline \square \\ \hline \square \\ \hline \end{array}_{\text{IR}} \oplus \begin{array}{|c|} \hline \square \\ \hline \square \\ \hline \end{array}_{\text{IR}} \oplus (12) \begin{array}{|c|} \hline \square \\ \hline \square \\ \hline \end{array}_{\text{IR}} \oplus (3) \begin{array}{|c|} \hline \square \\ \hline \square \\ \hline \end{array}_{\text{IR}} \oplus (3) \begin{array}{|c|} \hline \square \\ \hline \square \\ \hline \end{array}_{\text{IR}} \oplus \begin{array}{|c|} \hline \square \\ \hline \square \\ \hline \end{array}_{\text{IR}}, \\
 \text{Level-7} \quad (26) \boxed{8} \oplus (30) \square_{\text{IR}} \oplus (18) \begin{array}{|c|} \hline \boxed{8} \\ \hline \end{array}_{\text{IR}} \oplus (6) \begin{array}{|c|} \hline \boxed{8} \\ \hline \end{array}_{\text{IR}} \oplus (12) \square_{\text{IR}} \\
 \oplus (2) \square_{\text{IR}} \oplus (6) \begin{array}{|c|} \hline \square \\ \hline \square \\ \hline \end{array}_{\text{IR}} \oplus (2) \begin{array}{|c|} \hline \square \\ \hline \square \\ \hline \end{array}_{\text{IR}}, \\
 \text{Level-8} \quad (16) \cdot \oplus (19) \square_{\text{IR}} \oplus (21) \begin{array}{|c|} \hline \square \\ \hline \end{array}_{\text{IR}} \oplus (15) \square_{\text{IR}} \oplus (25) \begin{array}{|c|} \hline \square \\ \hline \square \\ \hline \end{array}_{\text{IR}} \oplus (4) \square_{\text{IR}} \\
 \oplus (17) \begin{array}{|c|} \hline \square \\ \hline \square \\ \hline \end{array}_{\text{IR}} \oplus (6) \begin{array}{|c|} \hline \square \\ \hline \square \\ \hline \end{array}_{\text{IR}} \oplus \square_{\text{IR}} \oplus (15) \begin{array}{|c|} \hline \square \\ \hline \square \\ \hline \end{array}_{\text{IR}} \oplus \begin{array}{|c|} \hline \square \\ \hline \square \\ \hline \end{array}_{\text{IR}} \\
 \oplus (3) \begin{array}{|c|} \hline \square \\ \hline \square \\ \hline \end{array}_{\text{IR}} \oplus (3) \begin{array}{|c|} \hline \square \\ \hline \square \\ \hline \end{array}_{\text{IR}} \oplus (4) \begin{array}{|c|} \hline \square \\ \hline \square \\ \hline \end{array}_{\text{IR}}, \\
 \vdots \quad \quad \quad \vdots
 \end{array} \right. \tag{5.6}$$

where Level-9 to Level-16 have exactly the same expressions as Level-7 to Level-0.

5.4 Index structures and irreducible conditions of component fields in 7D minimal scalar superfield

In this section, we will translate the irreducible bosonic and mixed Young Tableaux into field variables. We follow the same $\{\}$ -indices notation as well as “|” to separate indices in YT with different heights and “,” to separate indices in YT with the same heights.

The vector index \underline{a} runs from 0 to 6. The $\{\}$ -indices, irreducible bosonic Young Tableaux, and Dynkin Labels are equivalent and have the one-to-one correspondence.

The general expression is as below in equations (5.7) and (5.8),

$$\{\underline{a}_1, \dots, \underline{a}_p \mid \underline{b}_1 \underline{c}_1, \dots, \underline{b}_q \underline{c}_q \mid \underline{d}_1 \underline{e}_1 \underline{f}_1, \dots, \underline{d}_r \underline{e}_r \underline{f}_r\}$$

$$\begin{array}{cccccc}
 \boxed{\underline{a}_1} & \boxed{\underline{a}_p} & \begin{array}{|c|} \hline \underline{b}_1 \\ \hline \underline{c}_1 \\ \hline \end{array} & \begin{array}{|c|} \hline \underline{b}_q \\ \hline \underline{c}_q \\ \hline \end{array} & \begin{array}{|c|} \hline \underline{d}_1 \\ \hline \underline{e}_1 \\ \hline \underline{f}_1 \\ \hline \end{array} & \begin{array}{|c|} \hline \underline{d}_r \\ \hline \underline{e}_r \\ \hline \underline{f}_r \\ \hline \end{array} \\
 [p, 0, 0] & & [0, q, 0] & & [0, 0, 2r] &
 \end{array} \tag{5.7}$$

where above we have “disassembled” the YT to show how each column is affiliated with each type of subscript structure. Below we have assembled all the columns into a proper YT.

$$\begin{array}{|c|c|c|c|c|c|c|c|c|c|} \hline \underline{d}_1 & \dots & \underline{d}_r & \underline{b}_1 & \dots & \underline{b}_q & \underline{a}_1 & \dots & \underline{a}_p \\ \hline \underline{e}_1 & \dots & \underline{e}_r & \underline{c}_1 & \dots & \underline{c}_q & & & \\ \hline \underline{f}_1 & \dots & \underline{f}_r & & & & & & \\ \hline \end{array} \tag{5.8}$$

IR

[p, q, 2r]

As one moves from the YT’s shown in equation (5.7) to equation (5.8), it is clear the number of vertical boxes is tabulating the number of 1-forms, 2-forms, and 3-forms in the YT’s. These are the entries between the vertical | bars. These precisely correspond to the integers p , q , and r appeared in Dynkin Labels. An example of the correspondence between the subscript conventions, the affiliated YT, and Dynkin Label is shown in (5.9).

$$\{\underline{a}_2, \underline{a}_3 \mid \underline{a}_1 \underline{b}_1 \underline{c}_1\} \equiv \begin{array}{|c|c|c|} \hline \underline{a}_1 & \underline{a}_2 & \underline{a}_3 \\ \hline \underline{b}_1 \\ \hline \underline{c}_1 \\ \hline \end{array} \equiv [2, 0, 2]. \tag{5.9}$$

IR

The index structures as well as irreducible conditions of all bosonic and fermionic fields are identified below along with the level at which the fields occur in the adinkra of the scalar superfield. The spinor index α runs from 1 to 8.

- Level-0: $\Phi(x)$,
- Level-1: $(2) \Psi_\alpha(x)$,
- Level-2: $\Phi(x)$, $(3) \Phi_{\{\underline{a}_1\}}(x)$, $(3) \Phi_{\{\underline{a}_1 \underline{b}_1\}}(x)$, $\Phi_{\{\underline{a}_1 \underline{b}_1 \underline{c}_1\}}(x)$,
- Level-3: $(6) \Psi_\alpha(x)$, $(6) \Psi_{\{\underline{a}_1\}\alpha}(x) : (\gamma^{\underline{a}_1})_\beta{}^\alpha \Psi_{\{\underline{a}_1\}\alpha}(x) = 0$,
 $(2) \Psi_{\{\underline{a}_1 \underline{b}_1\}\alpha}(x) : (\gamma^{\underline{a}_1})_\beta{}^\alpha \Psi_{\{\underline{a}_1 \underline{b}_1\}\alpha}(x) = 0$,

- Level-4: (6) $\Phi(x)$, (8) $\Phi_{\{a_1\}}(x)$, (6) $\Phi_{\{a_1 b_1\}}(x)$, (6) $\Phi_{\{a_1, a_2\}}(x) : \eta^{a_1 a_2} \Phi_{\{a_1, a_2\}}(x) = 0$,
 (9) $\Phi_{\{a_1 b_1 c_1\}}(x)$, (4) $\Phi_{\{a_2 | a_1 b_1\}}(x) : \eta^{a_1 a_2} \Phi_{\{a_2 | a_1 b_1\}}(x) = 0$,
 $\Phi_{\{a_1 b_1, a_2 b_2\}}(x) : \begin{cases} \eta^{a_1 a_2} \Phi_{\{a_1 b_1, a_2 b_2\}}(x) = 0, \\ \eta^{a_1 a_2} \eta^{b_1 b_2} \Phi_{\{a_1 b_1, a_2 b_2\}}(x) = 0, \end{cases}$
 (3) $\Phi_{\{a_2 | a_1 b_1 c_1\}}(x) : \eta^{a_1 a_2} \Phi_{\{a_2 | a_1 b_1 c_1\}}(x) = 0$,
- Level-5: (16) $\Psi_\alpha(x)$, (18) $\Psi_{\{a_1\}\alpha}(x) : (\gamma^{a_1})_\beta \Psi_{\{a_1\}\alpha}(x) = 0$,
 (8) $\Psi_{\{a_1 b_1\}\alpha}(x) : (\gamma^{a_1})_\beta \Psi_{\{a_1 b_1\}\alpha}(x) = 0$,
 (4) $\Psi_{\{a_1 b_1 c_1\}\alpha}(x) : (\gamma^{a_1})_\beta \Psi_{\{a_1 b_1 c_1\}\alpha}(x) = 0$,
 $\Psi_{\{a_1, a_2\}\alpha}(x) : \begin{cases} (\gamma^{a_1})_\beta \Psi_{\{a_1, a_2\}\alpha}(x) \equiv \psi_{\{a_2\}\beta} = 0, \\ (\gamma^{a_2})_\gamma \psi_{\{a_2\}\beta} = 0, \end{cases}$
 $\Psi_{\{a_2 | a_1 b_1\}\alpha}(x) : \begin{cases} (\gamma^{b_1})_\beta \Psi_{\{a_2 | a_1 b_1\}\alpha}(x) \equiv \psi_{\{a_1, a_2\}\beta} = 0, \\ (\gamma^{a_2})_\beta \Psi_{\{a_2 | a_1 b_1\}\alpha}(x) \equiv \psi_{\{a_1 b_1\}\beta} = 0, \\ (\gamma^{b_1})_\gamma \psi_{\{a_1 b_1\}\beta} = 0, \end{cases}$
- Level-6: (6) $\Phi(x)$, (18) $\Phi_{\{a_1\}}(x)$, (21) $\Phi_{\{a_1 b_1\}}(x)$, (9) $\Phi_{\{a_1, a_2\}}(x) : \eta^{a_1 a_2} \Phi_{\{a_1, a_2\}}(x) = 0$,
 (15) $\Phi_{\{a_1 b_1 c_1\}}(x)$, (3) $\Phi_{\{a_1, a_2, a_3\}}(x) : \eta^{a_1 a_2} \Phi_{\{a_1, a_2, a_3\}}(x) = 0$,
 (12) $\Phi_{\{a_2 | a_1 b_1\}}(x) : \eta^{a_1 a_2} \Phi_{\{a_2 | a_1 b_1\}}(x) = 0$,
 $\Phi_{\{a_1 b_1, a_2 b_2\}}(x) : \begin{cases} \eta^{a_1 a_2} \Phi_{\{a_1 b_1, a_2 b_2\}}(x) = 0, \\ \eta^{a_1 a_2} \eta^{b_1 b_2} \Phi_{\{a_1 b_1, a_2 b_2\}}(x) = 0, \end{cases}$
 (12) $\Phi_{\{a_2 | a_1 b_1 c_1\}}(x) : \eta^{a_1 a_2} \Phi_{\{a_2 | a_1 b_1 c_1\}}(x) = 0$,
 $\Phi_{\{a_2, a_3 | a_1 b_1\}}(x) : \begin{cases} \eta^{a_2 a_3} \Phi_{\{a_2, a_3 | a_1 b_1\}}(x) = 0, \\ \eta^{b_1 a_3} \Phi_{\{a_2, a_3 | a_1 b_1\}}(x) = 0, \end{cases}$
 $\Phi_{\{a_2 b_2 | a_1 b_1 c_1\}}(x) : \begin{cases} \eta^{a_1 a_2} \Phi_{\{a_2 b_2 | a_1 b_1 c_1\}}(x) = 0, \\ \eta^{a_1 a_2} \eta^{b_1 b_2} \Phi_{\{a_2 b_2 | a_1 b_1 c_1\}}(x) = 0, \end{cases}$
 $\Phi_{\{a_2, a_3 | a_1 b_1 c_1\}}(x) : \begin{cases} \eta^{a_2 a_3} \Phi_{\{a_2, a_3 | a_1 b_1 c_1\}}(x) = 0, \\ \eta^{c_1 a_3} \Phi_{\{a_2, a_3 | a_1 b_1 c_1\}}(x) = 0, \end{cases}$
- Level-7: (26) $\Psi_\alpha(x)$, (30) $\Psi_{\{a_1\}\alpha}(x) : (\gamma^{a_1})_\beta \Psi_{\{a_1\}\alpha}(x) = 0$,
 (18) $\Psi_{\{a_1 b_1\}\alpha}(x) : (\gamma^{a_1})_\beta \Psi_{\{a_1 b_1\}\alpha}(x) = 0$,

$$\begin{aligned}
 & (6) \Psi_{\{a_1 b_1 c_1\} \alpha}(x) : (\gamma^{a_1})_{\beta}^{\alpha} \Psi_{\{a_1 b_1 c_1\} \alpha}(x) = 0, \\
 & (12) \Psi_{\{a_1, a_2\} \alpha}(x) : \begin{cases} (\gamma^{a_1})_{\beta}^{\alpha} \Psi_{\{a_1, a_2\} \alpha}(x) \equiv \psi_{\{a_2\} \beta} = 0, \\ (\gamma^{a_2})_{\gamma}^{\beta} \psi_{\{a_2\} \beta} = 0, \end{cases} \\
 & (2) \Psi_{\{a_1, a_2, a_3\} \alpha}(x) : \begin{cases} (\gamma^{a_1})_{\beta}^{\alpha} \Psi_{\{a_1, a_2, a_3\} \alpha}(x) \equiv \psi_{\{a_2, a_3\} \beta} = 0, \\ (\gamma^{a_2})_{\gamma}^{\beta} \psi_{\{a_2, a_3\} \beta} \equiv \psi_{\{a_3\} \gamma} = 0, \\ (\gamma^{a_3})_{\epsilon}^{\gamma} \psi_{\{a_3\} \gamma} = 0, \end{cases} \\
 & (6) \Psi_{\{a_2 | a_1 b_1\} \alpha}(x) : \begin{cases} (\gamma^{b_1})_{\beta}^{\alpha} \Psi_{\{a_2 | a_1 b_1\} \alpha}(x) \equiv \psi_{\{a_1, a_2\} \beta} = 0, \\ (\gamma^{a_2})_{\beta}^{\alpha} \Psi_{\{a_2 | a_1 b_1\} \alpha}(x) \equiv \psi_{\{a_1 b_1\} \beta} = 0, \\ (\gamma^{b_1})_{\gamma}^{\beta} \psi_{\{a_1 b_1\} \beta} = 0, \end{cases} \\
 & (2) \Psi_{\{a_2 | a_1 b_1 c_1\} \alpha}(x) : \begin{cases} (\gamma^{c_1})_{\beta}^{\alpha} \Psi_{\{a_2 | a_1 b_1 c_1\} \alpha}(x) \equiv \psi_{\{a_2 | a_1 b_1\} \beta} = 0, \\ (\gamma^{a_2})_{\beta}^{\alpha} \Psi_{\{a_2 | a_1 b_1 c_1\} \alpha}(x) \equiv \psi_{\{a_1 b_1 c_1\} \beta} = 0, \\ (\gamma^{c_1})_{\gamma}^{\beta} \psi_{\{a_1 b_1 c_1\} \beta} = 0, \end{cases} \\
 \bullet & \text{Level-8: } (16) \Phi(x), (19) \Phi_{\{a_1\}}(x), (21) \Phi_{\{a_1 b_1\}}(x), (15) \Phi_{\{a_1, a_2\}}(x) : \eta^{a_1 a_2} \Phi_{\{a_1, a_2\}}(x) = 0, \\
 & (25) \Phi_{\{a_1 b_1 c_1\}}(x), (4) \Phi_{\{a_1, a_2, a_3\}}(x) : \eta^{a_1 a_2} \Phi_{\{a_1, a_2, a_3\}}(x) = 0, \\
 & (17) \Phi_{\{a_2 | a_1 b_1\}}(x) : \eta^{a_1 a_2} \Phi_{\{a_2 | a_1 b_1\}}(x) = 0, \\
 & (6) \Phi_{\{a_1 b_1, a_2 b_2\}}(x) : \begin{cases} \eta^{a_1 a_2} \Phi_{\{a_1 b_1, a_2 b_2\}}(x) = 0, \\ \eta^{a_1 a_2} \eta^{b_1 b_2} \Phi_{\{a_1 b_1, a_2 b_2\}}(x) = 0, \end{cases} \\
 & \Phi_{\{a_1, a_2, a_3, a_4\}}(x) : \begin{cases} \eta^{a_1 a_2} \Phi_{\{a_1, a_2, a_3, a_4\}}(x) = 0, \\ \eta^{a_1 a_2} \eta^{a_3 a_4} \Phi_{\{a_1, a_2, a_3, a_4\}}(x) = 0, \end{cases} \\
 & (15) \Phi_{\{a_2 | a_1 b_1 c_1\}}(x) : \eta^{a_1 a_2} \Phi_{\{a_2 | a_1 b_1 c_1\}}(x) = 0, \\
 & \Phi_{\{a_1 b_1 c_1, a_2 b_2 c_2\}}(x) : \begin{cases} \eta^{a_1 a_2} \Phi_{\{a_1 b_1 c_1, a_2 b_2 c_2\}}(x) = 0, \\ \eta^{a_1 a_2} \eta^{b_1 b_2} \Phi_{\{a_1 b_1 c_1, a_2 b_2 c_2\}}(x) = 0, \\ \eta^{a_1 a_2} \eta^{b_1 b_2} \eta^{c_1 c_2} \Phi_{\{a_1 b_1 c_1, a_2 b_2 c_2\}}(x) = 0, \end{cases} \\
 & (3) \Phi_{\{a_2, a_3 | a_1 b_1\}}(x) : \begin{cases} \eta^{a_2 a_3} \Phi_{\{a_2, a_3 | a_1 b_1\}}(x) = 0, \\ \eta^{b_1 a_3} \Phi_{\{a_2, a_3 | a_1 b_1\}}(x) = 0, \end{cases} \\
 & (3) \Phi_{\{a_2 b_2 | a_1 b_1 c_1\}}(x) : \begin{cases} \eta^{a_1 a_2} \Phi_{\{a_2 b_2 | a_1 b_1 c_1\}}(x) = 0, \\ \eta^{a_1 a_2} \eta^{b_1 b_2} \Phi_{\{a_2 b_2 | a_1 b_1 c_1\}}(x) = 0, \end{cases}
 \end{aligned}$$

$$(4) \Phi_{\{a_2, a_3 | a_1 b_1 c_1\}}(x) : \begin{cases} \eta^{a_2 a_3} \Phi_{\{a_2, a_3 | a_1 b_1 c_1\}}(x) = 0, \\ \eta^{c_1 a_3} \Phi_{\{a_2, a_3 | a_1 b_1 c_1\}}(x) = 0, \end{cases}$$

5.5 (1, 0) multiplet decompositions

In seven spacetime dimensions, although we don't have chiral spinors, instead we have two copies of $[0, 0, 1]$ due to the $SU(2)$ -Majorana condition. Starting from one copy of $[0, 0, 1]$ spinor, we can construct a supermultiplet which is the subset of the one constructed from the minimal scalar superfield. We call it as $(1, 0)$ multiplet decomposition. Apply the Plethysm function and results are as below. Using branching rules for $\mathfrak{su}(8) \supset \mathfrak{so}(7)$ gives the same results. The projection matrix is presented in equation (B.8).

- Level-0: $[0, 0, 0]$ ($\{1\}$)
- Level-1: $[0, 0, 1]$ ($\{8\}$)
- Level-2: $[0, 1, 0]$ ($\{21\}$) \oplus $[1, 0, 0]$ ($\{7\}$)
- Level-3: $[1, 0, 1]$ ($\{48\}$) \oplus $[0, 0, 1]$ ($\{8\}$)
- Level-4: $[0, 0, 2]$ ($\{35\}$) \oplus $[2, 0, 0]$ ($\{27\}$) \oplus $[0, 0, 0]$ ($\{1\}$) \oplus $[1, 0, 0]$ ($\{7\}$)
- Level-5: $[1, 0, 1]$ ($\{48\}$) \oplus $[0, 0, 1]$ ($\{8\}$)
- Level-6: $[0, 1, 0]$ ($\{21\}$) \oplus $[1, 0, 0]$ ($\{7\}$)
- Level-7: $[0, 0, 1]$ ($\{8\}$)
- Level-8: $[0, 0, 0]$ ($\{1\}$)

Starting from the above decompositions, we can reproduce the minimal scalar superfield decompositions using the similar idea as when we construct 10D Type IIB scalar superfield from 10D Type I superfield. Basically we can label spinors as θ^α and θ^α both corresponding to the same irrep $[0, 0, 1]$. Then expand the scalar superfield only with respect to θ^α first. Namely,

$$\begin{aligned} \mathcal{V}(x, \theta^\alpha, \theta^\alpha) &= \mathcal{V}(x, \theta^\alpha) + \theta^\alpha \mathcal{V}_\alpha(x, \theta^\alpha) + \theta^\alpha \theta^\beta \mathcal{V}_{\alpha\beta}(x, \theta^\alpha) + \dots \\ &= \mathcal{V}^{(0)}(x) + \theta^\alpha \mathcal{V}_\alpha^{(1)}(x) + \theta^\alpha \theta^\beta \mathcal{V}_{\alpha\beta}^{(2)}(x) + \dots \\ &\quad + \theta^\alpha \left[\mathcal{V}_\alpha^{(0)}(x) + \theta^\alpha \mathcal{V}_{\alpha\alpha}^{(1)}(x) + \theta^\alpha \theta^\beta \mathcal{V}_{\alpha\alpha\beta}^{(2)}(x) + \dots \right] \\ &\quad + \theta^\alpha \theta^\beta \left[\mathcal{V}_{\alpha\beta}^{(0)}(x) + \theta^\alpha \mathcal{V}_{\alpha\beta\alpha}^{(1)}(x) + \theta^\alpha \theta^\beta \mathcal{V}_{\alpha\beta\alpha\beta}^{(2)}(x) + \dots \right] \\ &\quad + \dots \end{aligned} \tag{5.10}$$

which implies that for example, Level-2 in the scalar superfield decomposition is nothing but $(2) \{8\} \wedge \{8\} \oplus \{8\} \otimes \{8\} = \{1\} \oplus (3) \{7\} \oplus (3) \{21\} \oplus \{35\}$.

Last but not least, we can draw the adynkra and adinkra diagrams corresponding to the $(1, 0)$ multiplet, which are figures 9 and 10.

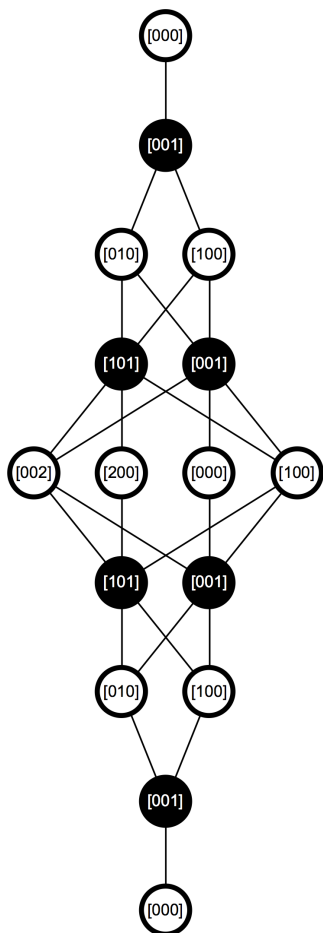

Figure 9. Adynkra Diagram for 7D (1,0) Multiplet.

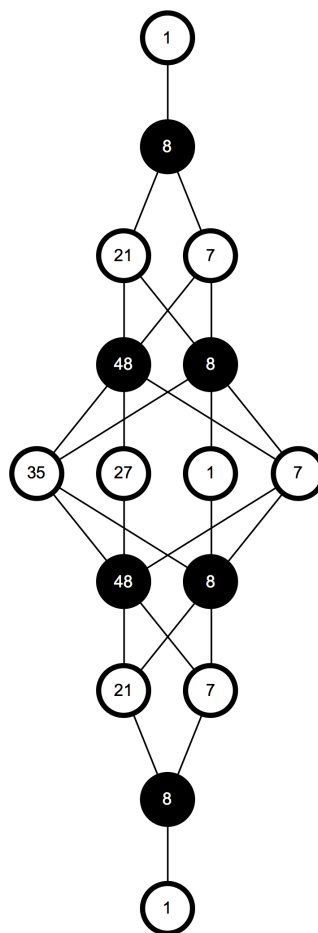

Figure 10. Adinkra Diagram for 7D (1,0) Multiplet.

6 6D minimal scalar superfield decomposition

6.1 Component decomposition results

The 6D minimal superfield component decomposition results by Dynkin Labels are listed below.

- Level-0: $[0, 0, 0]$
- Level-1: $[0, 1, 0] \oplus [0, 0, 1]$
- Level-2: $[0, 0, 0] \oplus (2)[1, 0, 0] \oplus [0, 1, 1]$
- Level-3: $(2)[0, 1, 0] \oplus (2)[0, 0, 1] \oplus [1, 0, 1] \oplus [1, 1, 0]$
- Level-4: $(3)[0, 0, 0] \oplus (2)[1, 0, 0] \oplus [0, 2, 0] \oplus [0, 0, 2] \oplus [0, 1, 1] \oplus [2, 0, 0]$
- Level-5: $(2)[0, 1, 0] \oplus (2)[0, 0, 1] \oplus [1, 0, 1] \oplus [1, 1, 0]$
- Level-6: $[0, 0, 0] \oplus (2)[1, 0, 0] \oplus [0, 1, 1]$

- Level-7: $[0, 1, 0] \oplus [0, 0, 1]$
- Level-8: $[0, 0, 0]$

And this is the component decomposition results by dimensions.

- Level-0: $\{1\}$
- Level-1: $\{4\} \oplus \{\bar{4}\}$
- Level-2: $\{1\} \oplus (2)\{6\} \oplus \{15\}$
- Level-3: $(2)\{4\} \oplus (2)\{\bar{4}\} \oplus \{20\} \oplus \{\bar{20}\}$
- Level-4: $(3)\{1\} \oplus (2)\{6\} \oplus \{10\} \oplus \{\bar{10}\} \oplus \{15\} \oplus \{20'\}$
- Level-5: $(2)\{4\} \oplus (2)\{\bar{4}\} \oplus \{20\} \oplus \{\bar{20}\}$
- Level-6: $\{1\} \oplus (2)\{6\} \oplus \{15\}$
- Level-7: $\{4\} \oplus \{\bar{4}\}$
- Level-8: $\{1\}$

6.2 6D minimal Adinkra diagram

The Adynkra and Adinkra diagrams for 6D minimal scalar superfield (up to Level-3) are figures 11 and 12. In six dimensions, we have two types of spinors having opposite chiralities. Thus we have two types of spinorial derivatives D_{α} and $D_{\bar{\alpha}}$. In figure 11 and 12 we use orange links to denote the supersymmetry transformations carried by D_{α} and green links for $D_{\bar{\alpha}}$.

6.3 Young Tableaux descriptions of component fields in 6D minimal scalar superfield

Consider the projection matrix for $\mathfrak{su}(6) \supset \mathfrak{so}(6)$ [9],

$$P_{\mathfrak{su}(6) \supset \mathfrak{so}(6)} = \begin{pmatrix} 1 & 0 & 0 & 0 & 1 \\ 0 & 1 & 0 & 1 & 0 \\ 0 & 1 & 2 & 1 & 0 \end{pmatrix}. \quad (6.1)$$

The highest weight of a specified irrep of $\mathfrak{su}(6)$ is a row vector $[p_1, p_2, p_3, p_4, p_5]$, where p_1 to p_5 are non-negative integers. Since the $\mathfrak{su}(6)$ YT with n vertical boxes is the conjugate of the one with $6 - n$ vertical boxes, we only need to consider the $p_4 = p_5 = 0$ case.

Starting from the weight vector $[p_1, p_2, p_3, 0, 0]$ in $\mathfrak{su}(6)$, we define its projected weight vector $[p_1, p_2, p_2 + 2p_3]$ in $\mathfrak{so}(6)$ as the Dynkin Label of the corresponding irreducible bosonic Young Tableau.

$$[p_1, p_2, p_2 + 2p_3] = [p_1, p_2, p_3, 0, 0] P_{\mathfrak{su}(6) \supset \mathfrak{so}(6)}^T. \quad (6.2)$$

Note that in 6D, duality condition needs to be considered for three-forms. Similar as the situation in 8D and 10D discussed in 4.3 and [3] respectively, the Dynkin Label $[p_1, p_2 + 2p_3, p_2]$

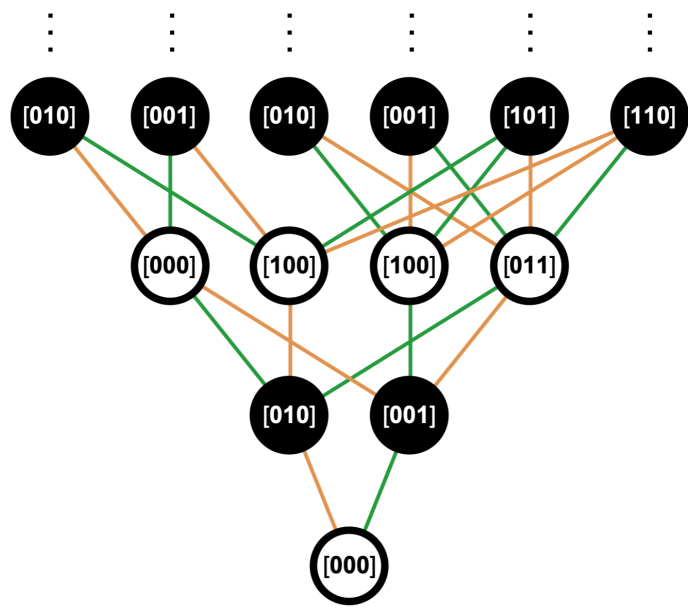

Figure 11. Adynkra Diagram for 6D minimal scalar superfield.

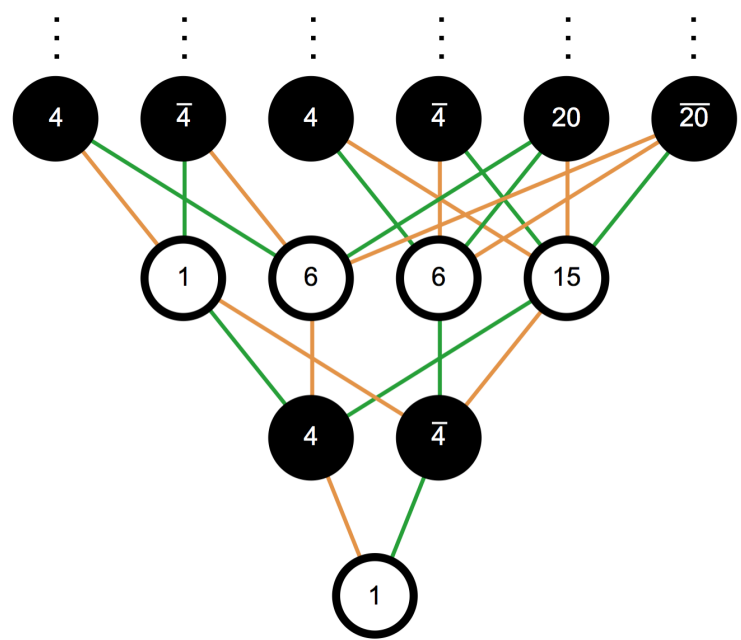

Figure 12. Adinkra Diagram for 6D minimal scalar superfield.

carries the same dimensionality and corresponds to the same YT shape as $[p_1, p_2, p_2 + 2p_3]$. Like in 10D, the three-form with Dynkin Label $[0, 0, 2]$ satisfies self-dual condition and the one with Dynkin Label $[0, 2, 0]$ satisfies anti-self-dual condition. Generally, the field/BYT corresponding to Dynkin Label $[p_1, p_2, p_2 + 2p_3]$ satisfies self-dual condition and the one with Dynkin Label $[p_1, p_2 + 2p_3, p_2]$ satisfies anti-self-dual condition.

Consider the congruence class of a representation with Dynkin Label $[a, b, c]$ in $\mathfrak{so}(6)$,

$$\begin{aligned} C_{c1}(R) &:= b + c \pmod{2}, \\ C_{c2}(R) &:= 2a + b + 3c \pmod{4}. \end{aligned} \tag{6.3}$$

Based on the above equation, there are totally four congruence classes in $\mathfrak{so}(6)$,

$$[C_{c1}, C_{c2}](R) = \begin{cases} [0, 0] \\ [0, 2] \\ [1, 1] \\ [1, 3] \end{cases} \tag{6.4}$$

$C_{c1}(R)$ actually classifies the bosonic irreps and spinorial irreps: $C_{c1}(R) = 0$ is bosonic and $C_{c1}(R) = 1$ is spinorial. Consequently, a bosonic irrep satisfies $|c - b| = 0 \pmod{2}$.

Given an irreducible bosonic Young Tableau with p_1 columns of one box, p_2 columns of two vertical boxes, and p_3 columns of three vertical boxes, the Dynkin Label of its corresponding bosonic irrep is $[p_1, p_2, p_2 + 2p_3]$ (or $[p_1, p_2 + 2p_3, p_2]$). Reversely, given a bosonic irrep with Dynkin Label $[a, b, c]$, its corresponding irreducible bosonic Young Tableau is composed of a columns of one box, $\min\{b, c\}$ columns of two vertical boxes, and $|c - b|/2$ columns of three vertical boxes.

The simplest examples, also the fundamental building blocks of an irreducible BYT, are given below.

$$\begin{aligned} \begin{array}{|c|} \hline \square \\ \hline \end{array}_{\text{IR}} &\equiv [1, 0, 0], & \begin{array}{|c|c|} \hline \square & \square \\ \hline \end{array}_{\text{IR}} &\equiv [0, 1, 1], \\ \begin{array}{|c|c|} \hline \square & \square \\ \hline \end{array}_{\text{IR},+} &\equiv [0, 0, 2], & \begin{array}{|c|c|c|} \hline \square & \square & \square \\ \hline \end{array}_{\text{IR},-} &\equiv [0, 2, 0]. \end{aligned} \tag{6.5}$$

For the YT satisfying self-dual condition, we use the subscript $\{\text{IR}, +\}$ to label it; and for the YT satisfying anti-self-dual condition, we use the subscript $\{\text{IR}, -\}$ to label it.

For spinorial irreps, the basic SYTs are defined by

$$\begin{aligned} \boxed{4} &\equiv [0, 1, 0], \\ \overline{\boxed{4}} &\equiv [0, 0, 1]. \end{aligned} \tag{6.6}$$

We could translate the Dynkin Label of any spinorial irrep to a mixed YT (which contains a BYT part and one of the basic SYTs above) with irreducible conditions by applying the same idea discussed in chapter five in [3].

Putting together the columns in (6.5) and (6.6) corresponds to adding their Dynkin Labels.

In summary, the irreducible Young Tableau descriptions of the 6D minimal scalar superfield decomposition is presented below.

$$\mathcal{V} = \left\{ \begin{array}{l} \text{Level } - 0 \quad \cdot, \\ \text{Level } - 1 \quad \boxed{4} \oplus \overline{\boxed{4}}, \\ \text{Level } - 2 \quad \cdot \oplus (2) \square_{\text{IR}} \oplus \begin{array}{|c|} \hline \square \\ \hline \end{array}_{\text{IR}}, \\ \text{Level } - 3 \quad (2) \boxed{4} \oplus (2) \overline{\boxed{4}} \oplus \begin{array}{|c|} \hline \square \\ \hline \end{array}_{\text{IR}} \oplus \begin{array}{|c|} \hline \square \\ \hline \end{array}_{\text{IR}}, \\ \text{Level } - 4 \quad (3) \cdot \oplus (2) \square_{\text{IR}} \oplus \begin{array}{|c|} \hline \square \\ \hline \square \\ \hline \end{array}_{\text{IR},-} \oplus \begin{array}{|c|} \hline \square \\ \hline \square \\ \hline \end{array}_{\text{IR},+} \oplus \begin{array}{|c|} \hline \square \\ \hline \end{array}_{\text{IR}} \oplus \begin{array}{|c|c|} \hline \square & \square \\ \hline \end{array}_{\text{IR}}, \\ \text{Level } - 5 \quad (2) \boxed{4} \oplus (2) \overline{\boxed{4}} \oplus \begin{array}{|c|} \hline \square \\ \hline \end{array}_{\text{IR}} \oplus \begin{array}{|c|} \hline \square \\ \hline \end{array}_{\text{IR}}, \\ \text{Level } - 6 \quad \cdot \oplus (2) \square_{\text{IR}} \oplus \begin{array}{|c|} \hline \square \\ \hline \end{array}_{\text{IR}}, \\ \text{Level } - 7 \quad \boxed{4} \oplus \overline{\boxed{4}}, \\ \text{Level } - 8 \quad \cdot. \end{array} \right. \quad (6.7)$$

6.4 Index structures and irreducible conditions of component fields in 6D minimal scalar superfield

In this section, we will translate the irreducible bosonic and mixed Young Tableaux into field variables. We follow the same $\{\}$ -indices notation as well as “|” to separate indices in YT with different heights and “,” to separate indices in YT with the same heights.

The vector index \underline{a} runs from 0 to 5. The $\{\}$ -indices, irreducible bosonic Young Tableaux, and Dynkin Labels are equivalent and have the one-to-one correspondence.

The general expression is as below in equations (6.8) and (6.9),

$$\{\underline{a}_1, \dots, \underline{a}_p \mid \underline{b}_1 \underline{c}_1, \dots, \underline{b}_q \underline{c}_q \mid \underline{d}_1 \underline{e}_1 \underline{f}_1, \dots, \underline{d}_r \underline{e}_r \underline{f}_r\}^{\pm}$$

$$\begin{array}{|c|} \hline \underline{a}_1 \\ \hline \end{array} \quad \begin{array}{|c|} \hline \underline{a}_p \\ \hline \end{array} \quad \begin{array}{|c|} \hline \underline{b}_1 \\ \hline \underline{c}_1 \\ \hline \end{array} \quad \begin{array}{|c|} \hline \underline{b}_q \\ \hline \underline{c}_q \\ \hline \end{array} \quad \begin{array}{|c|} \hline \underline{d}_1 \\ \hline \underline{e}_1 \\ \hline \underline{f}_1 \\ \hline \end{array} \quad \begin{array}{|c|} \hline \underline{d}_r \\ \hline \underline{e}_r \\ \hline \underline{f}_r \\ \hline \end{array} \quad (6.8)$$

$$\begin{array}{l} [\underline{p}, 0, 0] \quad [0, \underline{q}, \underline{q}] \quad [0, 0, 2r] \text{ with superscript } + \\ [0, 2r, 0] \text{ with superscript } - \end{array}$$

where above we have “disassembled” the YT to show how each column is affiliated with each type of subscript structure. Below we have assembled all the column into a proper YT.

$$\begin{array}{|c|c|c|c|c|c|} \hline \underline{d}_1 & \dots & \underline{d}_r & \underline{b}_1 & \dots & \underline{b}_q & \underline{a}_1 & \dots & \underline{a}_p \\ \hline \underline{e}_1 & \dots & \underline{e}_r & \underline{c}_1 & \dots & \underline{c}_q & & & \\ \hline \underline{f}_1 & \dots & \underline{f}_r & & & & & & \\ \hline \end{array} \quad \text{IR}, \pm \quad (6.9)$$

$$\begin{array}{l} [\underline{p}, \underline{q}, \underline{q} + 2r] \text{ with subscript } + \\ [\underline{p}, \underline{q} + 2r, \underline{q}] \text{ with subscript } - \end{array}$$

As one moves from the YT's shown in equation (6.8) to equation (6.9), it is clear the number of vertical boxes is tabulating the number of 1-forms, 2-forms, and 3-forms in the YT's. These are the entries between the vertical | bars. These precisely correspond to the integers p, q , and r appeared in Dynkin Labels. An example of the correspondence between the subscript conventions, the affiliated YT, and Dynkin Label is shown in (6.10).

$$\{a_2, a_3 | a_1 b_1\} \equiv \begin{array}{|c|c|c|} \hline a_1 & a_2 & a_3 \\ \hline b_1 & & \\ \hline \end{array} \underset{\text{IR}}{\equiv} [2, 1, 1]. \quad (6.10)$$

In 6D, we have two types of spinor indices corresponding to $\boxed{4}$ and $\overline{\boxed{4}}$ respectively. We define the field Ψ^α or $\Psi_{\dot{\alpha}}$ corresponds to $\boxed{4}$ and the field Ψ_α or $\Psi^{\dot{\alpha}}$ corresponds to $\overline{\boxed{4}}$. The spinor indices α and $\dot{\alpha}$ run from 1 to 4.

The index structures as well as irreducible conditions of all bosonic and fermionic fields are identified below along with the level at which the fields occur in the adinkra of the superfield.

- Level-0: $\Phi(x)$,
- Level-1: Ψ^α, Ψ_α ,
- Level-2: $\Phi(x), (2) \Phi_{\{a_1\}}(x), \Phi_{\{a_1 b_1\}}(x)$,
- Level-3: $(2) \Psi^\alpha, (2) \Psi_\alpha, \Psi_{\{a_1\}\alpha} : (\sigma^{a_1})^{\alpha\beta} \Psi_{\{a_1\}\alpha} = 0, \Psi_{\{a_1\}}^\alpha : (\sigma^{a_1})_{\alpha\beta} \Psi_{\{a_1\}}^\alpha = 0$,
- Level-4: $(3) \Phi(x), (2) \Phi_{\{a_1\}}(x), \Phi_{\{a_1 b_1 c_1\}^-}(x), \Phi_{\{a_1 b_1 c_1\}^+}(x), \Phi_{\{a_1 b_1\}}(x), \Phi_{\{a_1, a_2\}}(x) : \eta^{a_1 a_2} \Phi_{\{a_1, a_2\}}(x) = 0$.

Level-5 to Level-8 have exactly the same expressions as Level-3 to Level-0.

6.5 (1, 0) multiplet decompositions

Similarly as in 8D, in 6D spinors also split into two pieces: $[0, 1, 0] \oplus [0, 0, 1]$ ($\boxed{4} \oplus \overline{\boxed{4}}$). Therefore, we can study the subset of decomposition results which generated solely by $[0, 1, 0]$ or $[0, 0, 1]$. The results obtained by only considering $[0, 1, 0]$ ($\boxed{4}$) piece are as below, which are called (1, 0) multiplet decomposition.

- Level-0: $[0, 0, 0]$ ($\boxed{1}$)
- Level-1: $[0, 1, 0]$ ($\boxed{4}$)
- Level-2: $[1, 0, 0]$ ($\boxed{6}$)
- Level-3: $[0, 0, 1]$ ($\overline{\boxed{4}}$)
- Level-4: $[0, 0, 0]$ ($\boxed{1}$)

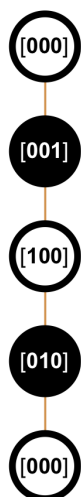

Figure 13. Adynkra Diagram for 6D (1,0) Multiplet.

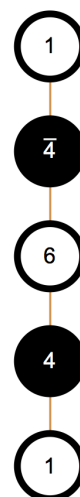

Figure 14. Adinkra Diagram for 6D (1,0) Multiplet.

Starting from the (1, 0) multiplet decomposition, we can reproduce the scalar superfield decomposition following the same procedures discussed in 8D. Basically we can label spinors as θ^α and $\theta^{\dot{\alpha}}$ corresponding to $[0, 1, 0]$ and $[0, 0, 1]$ respectively. Then expand the scalar superfield only with respect to $\theta^{\dot{\alpha}}$ first where the accompanying component fields are actually (1,0) superfields. For example, Level-2 in the scalar superfield decomposition is nothing but $\{4\} \wedge \{4\} \oplus \{4\} \wedge \{4\} \oplus \{4\} \otimes \{4\} = \{1\} \oplus (2)\{6\} \oplus \{15\}$.

Last but not least, we can draw the adynkra and adinkra diagrams corresponding to the (1,0) multiplet, which are figures 13 and 14.

7 5D minimal scalar superfield decomposition

7.1 Component decomposition results

The 5D minimal scalar superfield component decomposition results by Dynkin Labels are given below.

- Level-0: $[0, 0]$
- Level-1: $(2)[0, 1]$
- Level-2: $(3)[0, 0] \oplus (3)[1, 0] \oplus [0, 2]$
- Level-3: $(6)[0, 1] \oplus (2)[1, 1]$
- Level-4: $(6)[0, 0] \oplus (4)[1, 0] \oplus (3)[0, 2] \oplus [2, 0]$
- Level-5: $(6)[0, 1] \oplus (2)[1, 1]$
- Level-6: $(3)[0, 0] \oplus (3)[1, 0] \oplus [0, 2]$

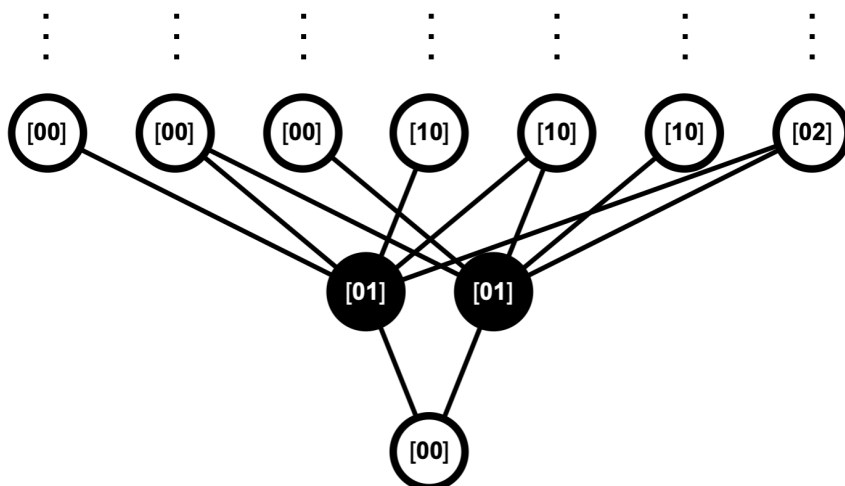

Figure 15. Adynkra Diagram for 5D minimal scalar superfield.

- Level-7: $(2)[0, 1]$
- Level-8: $[0, 0]$

The corresponding component decomposition results by dimensions are as follows.

- Level-0: $\{1\}$
- Level-1: $(2)\{4\}$
- Level-2: $(3)\{1\} \oplus (3)\{5\} \oplus \{10\}$
- Level-3: $(6)\{4\} \oplus (2)\{16\}$
- Level-4: $(6)\{1\} \oplus (4)\{5\} \oplus (3)\{10\} \oplus \{14\}$
- Level-5: $(6)\{4\} \oplus (2)\{16\}$
- Level-6: $(3)\{1\} \oplus (3)\{5\} \oplus \{10\}$
- Level-7: $(2)\{4\}$
- Level-8: $\{1\}$

7.2 5D minimal Adinkra diagram

The Adynkra and Adinkra diagrams for 5D minimal scalar superfield (up to Level-2) are figures 15 and 16.

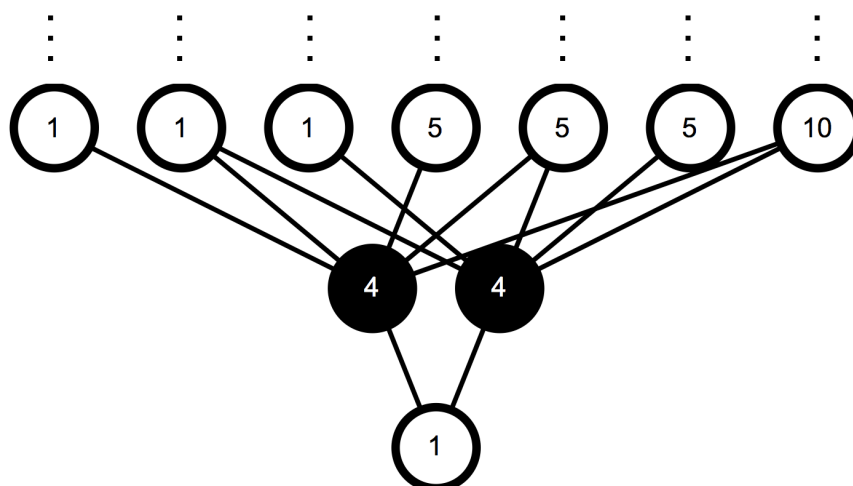

Figure 16. Adinkra Diagram for 5D minimal scalar superfield.

7.3 Young Tableaux descriptions of component fields in 5D minimal scalar superfield

Consider the projection matrix for $\mathfrak{su}(5) \supset \mathfrak{so}(5)$ [9],

$$P_{\mathfrak{su}(5) \supset \mathfrak{so}(5)} = \begin{pmatrix} 1 & 0 & 0 & 1 \\ 0 & 2 & 2 & 0 \end{pmatrix}. \tag{7.1}$$

The highest weight of a specified irrep of $\mathfrak{su}(5)$ is a row vector $[p_1, p_2, p_3, p_4]$, where p_1 to p_4 are non-negative integers. Since the $\mathfrak{su}(5)$ YT with n vertical boxes is the conjugate of the one with $5 - n$ vertical boxes, we need only consider the $p_3 = p_4 = 0$ case.

Starting from the weight vector $[p_1, p_2, 0, 0]$ in $\mathfrak{su}(5)$, we define its projected weight vector $[p_1, 2p_2]$ in $\mathfrak{so}(5)$ as the Dynkin Label of the corresponding irreducible bosonic Young Tableau.

$$[p_1, 2p_2] = [p_1, p_2, 0, 0] P_{\mathfrak{su}(5) \supset \mathfrak{so}(5)}^T. \tag{7.2}$$

The congruence class of a representation with Dynkin Label $[a, b]$ in $\mathfrak{so}(5)$ is

$$C_c(R) := b \pmod{2}, \tag{7.3}$$

which classifies the bosonic irreps and spinorial irreps: $C_c(R) = 0$ is bosonic and $C_c(R) = 1$ is spinorial.

Given an irreducible bosonic Young Tableau with p_1 columns of one box and p_2 columns of two vertical boxes, the Dynkin Label of its corresponding bosonic irrep is $[p_1, 2p_2]$. Reversely, given a bosonic irrep with Dynkin Label $[a, b]$, its corresponding irreducible bosonic Young Tableau is composed of a columns of one box and $b/2$ columns of two vertical boxes.

The simplest examples, also the fundamental building blocks of an irreducible BYT, are given below.

$$\square_{\text{IR}} \equiv [1, 0], \quad \begin{array}{|c|} \hline \square \\ \hline \square \\ \hline \end{array}_{\text{IR}} \equiv [0, 2]. \tag{7.4}$$

For spinorial irreps, the basic SYT is given by

$$\boxed{4} \equiv [0, 1]. \tag{7.5}$$

We could translate the Dynkin Label of any spinorial irrep to a mixed YT (which contains a BYT part and a basic SYT above) with irreducible conditions by applying the same idea discussed in chapter five in [3].

Putting together the columns in (7.4) and (7.5) corresponds to adding their Dynkin Labels.

In summary, the irreducible Young Tableau descriptions of the 5D minimal scalar superfield decomposition is presented below.

$$\mathcal{V} = \left\{ \begin{array}{ll} \text{Level } - 0 & \cdot, \\ \text{Level } - 1 & (2) \boxed{4}, \\ \text{Level } - 2 & (3) \cdot \oplus (3) \boxed{}_{\text{IR}} \oplus \boxed{}_{\text{IR}}, \\ \text{Level } - 3 & (6) \boxed{4} \oplus (2) \boxed{}_{\text{IR}}, \\ \text{Level } - 4 & (6) \cdot \oplus (4) \boxed{}_{\text{IR}} \oplus (3) \boxed{}_{\text{IR}} \oplus \boxed{}_{\text{IR}}, \\ \text{Level } - 5 & (6) \boxed{4} \oplus (2) \boxed{}_{\text{IR}}, \\ \text{Level } - 6 & (3) \cdot \oplus (3) \boxed{}_{\text{IR}} \oplus \boxed{}_{\text{IR}}, \\ \text{Level } - 7 & (2) \boxed{4}, \\ \text{Level } - 8 & \cdot. \end{array} \right. \tag{7.6}$$

7.4 Index structures and irreducible conditions of component fields in 5D minimal scalar superfield

In this section, we will translate the irreducible bosonic and mixed Young Tableaux into field representation. We follow the same {}-indices notation as well as “|” to separate indices in YT with different heights and “,” to separate indices in YT with the same heights.

The vector index \underline{a} runs from 0 to 4. The {}-indices, irreducible bosonic Young Tableaux, and Dynkin Labels are equivalent and have the one-to-one correspondence.

The general expression is as below in equations (7.7) and (7.8),

$$\{\underline{a}_1, \dots, \underline{a}_p \mid \underline{b}_1 \underline{c}_1, \dots, \underline{b}_q \underline{c}_q\}$$

$$\begin{array}{cccc} \boxed{\underline{a}_1} & \boxed{\underline{a}_p} & \boxed{\underline{b}_1} & \boxed{\underline{b}_q} \\ & & \boxed{\underline{c}_1} & \boxed{\underline{c}_q} \end{array} \tag{7.7}$$

$$[\underline{p}, 0] \qquad [0, 2q]$$

where above we have “disassembled” the YT to show how each column is affiliated with each type of subscript structure. Below we have assembled all the column into a proper YT.

$$\begin{array}{|c|c|c|c|c|} \hline \underline{b}_1 & \cdots & \underline{b}_q & \underline{a}_1 & \cdots & \underline{a}_p \\ \hline \underline{c}_1 & \cdots & \underline{c}_q & & & \\ \hline \end{array} \quad \text{IR} \tag{7.8}$$

$$[p, 2q]$$

As one moves from the YT’s shown in equation (7.7) to equation (7.8), it is clear the number of vertical boxes is tabulating the number of 1-forms and 2-forms in the YT’s. These are the entries between the vertical | bars. These precisely correspond to the integers p and q appeared in Dynkin Labels. An example of the correspondence between the subscript conventions, the affiliated YT, and Dynkin Label is shown in (7.9).

$$\{ \underline{a}_2, \underline{a}_3 | \underline{a}_1 \underline{b}_1 \} \equiv \begin{array}{|c|c|c|} \hline \underline{a}_1 & \underline{a}_2 & \underline{a}_3 \\ \hline \underline{b}_1 & & \\ \hline \end{array} \equiv [2, 2]. \tag{7.9}$$

The index structures as well as irreducible conditions of all bosonic and fermionic fields are identified below along with the level at which the fields occur in the adinkra of the superfield. The spinor index α runs from 1 to 4.

- Level-0: $\Phi(x)$,
- Level-1: $(2) \Psi_\alpha$,
- Level-2: $(3) \Phi(x)$, $(3) \Phi_{\{\underline{a}_1\}}(x)$, $\Phi_{\{\underline{a}_1 \underline{b}_1\}}(x)$,
- Level-3: $(6) \Psi_\alpha$, $(2) \Psi_{\{\underline{a}_1\}\alpha} : (\gamma^{\underline{a}_1})^{\alpha\beta} \Psi_{\{\underline{a}_1\}\alpha} = 0$,
- Level-4: $(6) \Phi(x)$, $(4) \Phi_{\{\underline{a}_1\}}(x)$, $(3) \Phi_{\{\underline{a}_1 \underline{b}_1\}}(x)$,
 $\Phi_{\{\underline{a}_1, \underline{a}_2\}}(x) : \eta^{\underline{a}_1 \underline{a}_2} \Phi_{\{\underline{a}_1, \underline{a}_2\}}(x) = 0$.

Level-5 to Level-8 have exactly the same expressions as Level-3 to Level-0.

7.5 (1, 0) multiplet decompositions

In five spacetime dimensions, the story is pretty similar as in seven dimensions since in both cases SU(2)-Majorana condition plays an important role. Consequently we have two copies of $[0, 1]$. Start from one copy of $[0, 1]$ spinor, we can also construct a supermultiplet called $(1, 0)$ multiplet which is the subset of the one constructed from the scalar superfield. Apply the Plethysm function and results are as below. Using branching rules for $\mathfrak{su}(4) \supset \mathfrak{so}(5)$ gives the same results. The projection matrix is presented in equation (B.10).

- Level-0: $[0, 0] \{1\}$
- Level-1: $[0, 1] \{4\}$
- Level-2: $[1, 0] \{5\} \oplus [0, 0] \{1\}$

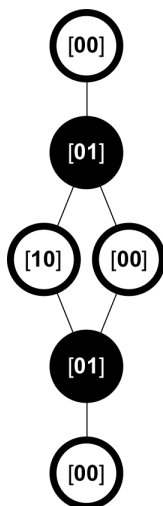

Figure 17. Adynkra Diagram for 5D (1,0) Multiplet.

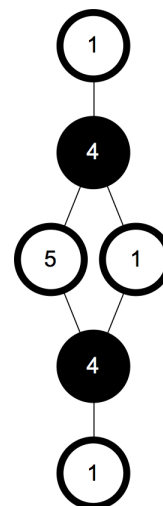

Figure 18. Adinkra Diagram for 5D (1,0) Multiplet.

- Level-3: $[0, 1]$ ($\{4\}$)
- Level-4: $[0, 0]$ ($\{1\}$)

Starting from the above decomposition and we can reproduce the scalar superfield decomposition using the similar idea as in 7D. Basically we can label spinors as θ^α and θ^α both corresponding to the same irrep $[0, 1]$. Then expand the scalar superfield only with respect to θ^α first. For example, Level-2 in the scalar superfield decomposition is nothing but $(2) \{4\} \wedge \{4\} \oplus \{4\} \otimes \{4\} = (3) \{1\} \oplus (3) \{5\} \oplus \{10\}$.

Last but not least, we can draw the adynkra and adinkra diagrams corresponding to the (1, 0) multiplet, which are figures 17 and 18.

8 4D minimal scalar superfield decomposition

8.1 Component decomposition results

The 4D minimal scalar superfield component decomposition results by Dynkin Labels is given as follows.

- Level-0: $[0, 0]$
- Level-1: $[1, 0] \oplus [0, 1]$
- Level-2: $(2)[0, 0] \oplus [1, 1]$
- Level-3: $[1, 0] \oplus [0, 1]$
- Level-4: $[0, 0]$

Here we also list the component decomposition results by dimensions.

- Level-0: $\{1\}$

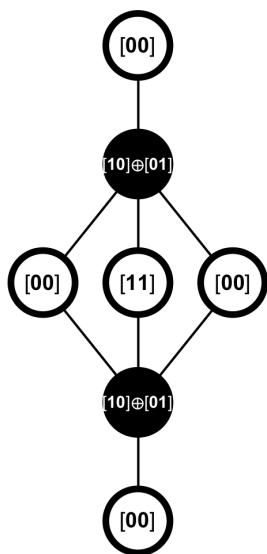

Figure 19. Adynkra Diagram for 4D minimal scalar superfield.

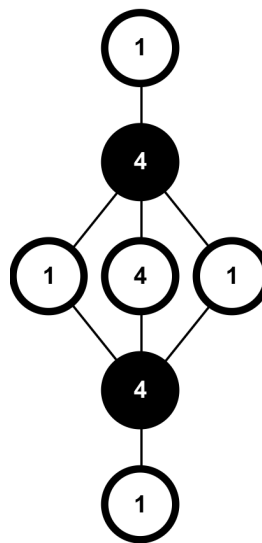

Figure 20. Adinkra Diagram for 4D minimal scalar superfield.

- Level-1: $\{2\} \oplus \{\bar{2}\}$
- Level-2: $(2)\{1\} \oplus \{4\}$
- Level-3: $\{2\} \oplus \{\bar{2}\}$
- Level-4: $\{1\}$

In table 1, we see that 4D is the only dimension there are two choices of spinor conventions, 2-component Weyl spinors or 4-component Majorana spinors. Here $\{2\} \oplus \{\bar{2}\}$ corresponds to two-component Weyl spinors ψ_α and $\bar{\psi}_{\dot{\alpha}}$, where $\alpha, \dot{\alpha} = 1, 2$ and the superspace takes the form $(x^a, \theta^\alpha, \bar{\theta}^{\dot{\alpha}})$. However, we could also adopt the Majorana spinor convention, where we put together the two 2-component Weyl spinors into one 4-component Majorana spinor. In that case, we have ψ_α that corresponds to $\{4\} = \{2\} \oplus \{\bar{2}\}$, and our superspace looks like (x^a, θ^α) with $\alpha = 1, \dots, 4$. If we choose the Majorana notation, the 4D results here agree with what appeared in our previous work [1]. In the rest of this section, we will stick to the Majorana spinor convention.

8.2 4D minimal Adinkra diagram

The Adynkra and Adinkra diagrams for 4D minimal scalar superfield are figures 19 and 20.

8.3 Young Tableaux descriptions of component fields in 4D minimal scalar superfield

Consider the projection matrix for $\mathfrak{su}(4) \supset \mathfrak{so}(4)$ [9],

$$P_{\mathfrak{su}(4) \supset \mathfrak{so}(4)} = \begin{pmatrix} 1 & 0 & 1 \\ 1 & 2 & 1 \end{pmatrix}. \tag{8.1}$$

The highest weight of a specified irrep of $\mathfrak{su}(4)$ is a row vector $[p_1, p_2, p_3]$, where p_1 to p_3 are non-negative integers. Since the $\mathfrak{su}(4)$ YT with n vertical boxes is the conjugate of the one with $4 - n$ vertical boxes, we only need to consider the $p_3 = 0$ case.

Starting from the weight vector $[p_1, p_2, 0]$ in $\mathfrak{su}(4)$, we define its projected weight vector $[p_1, p_1 + 2p_2]$ in $\mathfrak{so}(4)$ as the Dynkin Label of the corresponding irreducible bosonic Young Tableau.

$$[p_1, p_1 + 2p_2] = [p_1, p_2, 0] P_{\mathfrak{su}(4) \supset \mathfrak{so}(4)}^T. \tag{8.2}$$

Note that in 4D, duality condition needs to be considered for two-form. Similar as the situations in 6D, 8D and 10D discussed in 6.3, 4.3 and [3] respectively, the Dynkin Label $[p_1 + 2p_2, p_1]$ carries the same dimensionality and corresponds to the same YT shape as $[p_1, p_1 + 2p_2]$. Like in 10D, the two-form with Dynkin Label $[0, 2]$ satisfies self-dual condition and the one with Dynkin Label $[2, 0]$ satisfies anti-self-dual condition. Generally, the field/BYT corresponding to Dynkin Label $[p_1, p_1 + 2p_2]$ satisfies self-dual condition and the one with Dynkin Label $[p_1 + 2p_2, p_1]$ satisfies anti-self-dual condition.

Given an irreducible bosonic Young Tableau with p_1 columns of one box and p_2 columns of two vertical boxes, the Dynkin Label of its corresponding bosonic irrep is $[p_1, p_1 + 2p_2]$ (or $[p_1 + 2p_2, p_1]$). Reversely, given a bosonic irrep with Dynkin Label $[a, b]$, its corresponding irreducible bosonic Young Tableau is composed of $\min\{a, b\}$ columns of one box and $|b - a|/2$ columns of two vertical boxes.

The simplest examples, also the fundamental building blocks of an irreducible NYT, are given below.

$$\square_{\text{IR}} \equiv [1, 1], \quad \begin{array}{|c|} \hline \square \\ \hline \square \\ \hline \end{array}_{\text{IR},+} \equiv [0, 2], \quad \begin{array}{|c|} \hline \square \\ \hline \square \\ \hline \end{array}_{\text{IR},-} \equiv [2, 0]. \tag{8.3}$$

For spinorial irreps, by adopting the Majorana convention, the basic NYT is

$$\boxed{4} \equiv [1, 0] \oplus [0, 1]. \tag{8.4}$$

Putting together the columns in (8.3) and (8.4) corresponds to adding their Dynkin Labels.

In summary, if we adopt the 4-component Majorana notation, the irreducible Young Tableau descriptions of the 4D minimal scalar superfield decomposition can be presented as follows.

$$\mathcal{V} = \begin{cases} \text{Level } - 0 & \cdot, \\ \text{Level } - 1 & \boxed{4}, \\ \text{Level } - 2 & (2) \cdot \oplus \square_{\text{IR}}, \\ \text{Level } - 3 & \boxed{4}, \\ \text{Level } - 4 & \cdot. \end{cases} \tag{8.5}$$

8.4 Index structures and irreducible conditions of component fields in 4D minimal scalar superfield

In this section, we will translate the irreducible bosonic Young Tableaux into field representation. We follow the same $\{\}$ -indices notation as well as “|” to separate indices in YT with different heights and “,” to separate indices in YT with the same heights.

The vector index \underline{a} runs from 0 to 3. The $\{\}$ -indices, irreducible bosonic Young Tableaux, and Dynkin Labels are equivalent and have the one-to-one correspondence.

The general expression is as below in equations (8.6) and (8.7),

$$\{\underline{a}_1, \dots, \underline{a}_p \mid \underline{b}_1 \underline{c}_1, \dots, \underline{b}_q \underline{c}_q\}^\pm$$

$$\begin{array}{|c|} \hline \underline{a}_1 \\ \hline \end{array} \quad \begin{array}{|c|} \hline \underline{a}_p \\ \hline \end{array} \quad \begin{array}{|c|} \hline \underline{b}_1 \\ \hline \underline{c}_1 \\ \hline \end{array} \quad \begin{array}{|c|} \hline \underline{b}_q \\ \hline \underline{c}_q \\ \hline \end{array} \tag{8.6}$$

$$\begin{array}{l} [\mathbf{p}, \mathbf{p}] \\ [0, 2\mathbf{q}] \text{ with superscript } + \\ [2\mathbf{q}, 0] \text{ with superscript } - \end{array}$$

where above we have “disassembled” the YT to show how each column is affiliated with each type of subscript structure. Below we have assembled all the columns into a proper YT.

$$\begin{array}{|c|c|c|c|} \hline \underline{b}_1 & \dots & \underline{b}_q & \underline{a}_1 \dots \underline{a}_p \\ \hline \underline{c}_1 & \dots & \underline{c}_q & \\ \hline \end{array} \quad \text{IR}, \pm \tag{8.7}$$

$$\begin{array}{l} [\mathbf{p}, \mathbf{p} + 2\mathbf{q}] \text{ with superscript } + \\ [\mathbf{p} + 2\mathbf{q}, \mathbf{p}] \text{ with superscript } - \end{array}$$

As one moves from the YT’s shown in equation (8.6) to equation (8.7), it is clear the number of vertical boxes is tabulating the number of 1-forms and 2-forms in the YT’s. These are the entries between the vertical $|$ bars. These precisely correspond to the Dynkin Labels p and q . An example of the correspondence between the subscript conventions, the affiliated YT, and Dynkin Label is shown in (8.8).

$$\{\underline{a}_2, \underline{a}_3 \mid \underline{a}_1 \underline{b}_1\} \equiv \begin{array}{|c|c|c|} \hline \underline{a}_1 & \underline{a}_2 & \underline{a}_3 \\ \hline \underline{b}_1 & & \\ \hline \end{array} \quad \text{IR}, + \equiv [2, 4]. \tag{8.8}$$

The index structures as well as irreducible conditions of all bosonic and fermionic fields are identified below along with the level at which the fields occur in the adinkra of the superfield. The Majorana spinor index α runs from 1 to 4.

- Level-0: $\Phi(x)$,
- Level-1: $\Psi_\alpha(x)$,
- Level-2: $(2) \Phi(x)$, $\Phi_{\{\underline{a}_1\}}(x)$,
- Level-3: $\Psi^\alpha(x)$,
- Level-4: $\Phi(x)$.

9 Conclusion

In this work, we have established the basic libraries of adynkras that can be used to explore problems of embedding component fields into superfields in the context of spacetimes with Lorentzian signature and $D - 1$ spatial dimensions where $4 \leq D \leq 9$. In addition to minimal scalar superfields, we also explored $(1, 0)$ multiplets in several dimensions.

How to write the complete set of supersymmetry transformations for these component fields is an important question. In every adynkra diagram we draw, the supersymmetry transformations are determined by a sufficient but not necessary condition as stated in section 8.3 of [3]. A fully satisfactory answer would require the construction of supercovariant derivative operators acting on adynkrafields. We will discuss the 4D case in a paper in preparation and its generalizations deserve further study.

The importance of the adynkra libraries is that for the first time in the history of the subject of supersymmetry, these will support the creation of algorithms that solve the embedding problem. One can now start with *any* spectrum of on-shell component fields in these various dimensions and algorithmically *derive* the minimal dimension superfield representation (as well as alternatives) that contains this specified component field spectrum. The technique for this has been christened as an “adynkra digital analysis” (ADA) scan as described in the work of [13].

I am thinking about something much more important than bombs. I am thinking about computers.”

John von Neumann

Acknowledgments

The research of S.J.G., Y. Hu, and S.-N. Mak is supported in part by the endowment of the Ford Foundation Professorship of Physics at Brown University and they gratefully acknowledge the support of the Brown Theoretical Physics Center. The authors highly appreciate the reviewer’s insightful and helpful feedback on our manuscript.

A Irreducible representations

Here we list parts of irreducible representations by both Dynkin labels and dimensionalities of Lorentz algebras in 9D to 4D [9].

Dynkin label	Dimension
[0,0,0,0]	1
[1,0,0,0]	9
[0,0,0,1]	16
[0,1,0,0]	36
[2,0,0,0]	44
[0,0,1,0]	84
[0,0,0,2]	126
[1,0,0,1]	128
[3,0,0,0]	156
[1,1,0,0]	231
[0,1,0,1]	432
[4,0,0,0]	450
[0,2,0,0]	495
[2,0,0,1]	576
[1,0,1,0]	594
[0,0,0,3]	672
[0,0,1,1]	768
[2,1,0,0]	910
[1,0,0,2]	924

Table 2. $\mathfrak{so}(9)$ irreducible representations #1 [9].

Dynkin label	Dimension
[5,0,0,0]	1122
[0,1,1,0]	1650
[3,0,0,1]	1920
[0,0,2,0]	1980
[2,0,1,0]	2457
[6,0,0,0]	2508
[1,1,0,1]	2560
[1,2,0,0]	2574
[0,1,0,2]	2772
[0,0,0,4]	2772'
[3,1,0,0]	2772''
[2,0,0,2]	3900
[0,3,0,0]	4004
[0,0,1,2]	4158
[1,0,0,3]	4608
[0,2,0,1]	4928
[1,0,1,1]	5040

Table 3. $\mathfrak{so}(9)$ irreducible representations #2 [9].

Dynkin label	Dimension
[0,0,0,0]	1
[1,0,0,0]	8_v
[0,0,0,1]	8_s
[0,0,1,0]	8_c
[0,1,0,0]	28
[2,0,0,0]	35_v
[0,0,2,0]	35_c
[0,0,0,2]	35_s
[0,0,1,1]	56_v
[1,0,1,0]	56_s
[1,0,0,1]	56_c
[3,0,0,0]	112_v
[0,0,0,3]	112_s
[0,0,3,0]	112_c
[1,1,0,0]	160_v
[0,1,0,1]	160_s
[0,1,1,0]	160_c
[1,0,2,0]	224_{cv}
[1,0,0,2]	224_{sv}
[2,0,0,1]	224_{vs}
[0,0,2,1]	224_{cs}
[2,0,1,0]	224_{vc}
[0,0,1,2]	224_{sc}
[4,0,0,0]	294_v
[0,0,4,0]	294_c
[0,0,0,4]	294_s

Table 4. $\mathfrak{so}(8)$ irreducible representations #1 [9].

Dynkin label	Dimension
[0,2,0,0]	300
[1,0,1,1]	350
[2,1,0,0]	567 _v
[0,1,2,0]	567 _c
[0,1,0,2]	567 _s
[0,0,3,1]	672 _{cs}
[0,0,1,3]	672 _{sc}
[3,0,1,0]	672 _{vc}
[1,0,3,0]	672 _{cv}
[3,0,0,1]	672 _{vs}
[1,0,0,3]	672 _{sv}
[5,0,0,0]	672' _v
[0,0,0,5]	672' _s
[0,0,5,0]	672' _c
[0,1,1,1]	840 _v
[1,1,1,0]	840 _s
[1,1,0,1]	840 _c
[2,0,2,0]	840' _s
[2,0,0,2]	840' _c
[0,0,2,2]	840' _v
[2,0,1,1]	1296 _v
[1,0,1,2]	1296 _s
[1,0,2,1]	1296 _c

Table 5. $\mathfrak{so}(8)$ irreducible representations #2 [9].

Dynkin label	Dimension
[0,0,0]	1
[1,0,0]	7
[0,0,1]	8
[0,1,0]	21
[2,0,0]	27
[0,0,2]	35
[1,0,1]	48
[3,0,0]	77
[1,1,0]	105
[0,1,1]	112
[0,0,3]	112'
[2,0,1]	168
[0,2,0]	168'
[4,0,0]	182
[1,0,2]	189
[0,0,4]	294
[2,1,0]	330
[0,1,2]	378
[5,0,0]	378'
[3,0,1]	448
[1,1,1]	512
[1,0,3]	560
[2,0,2]	616

Table 6. $\mathfrak{so}(7)$ irreducible representations [9].

Dynkin label	Dimension
[0,0,0]	1
[0,1,0]	4
[0,0,1]	$\bar{4}$
[1,0,0]	6
[0,2,0]	10
[0,0,2]	$\bar{10}$
[0,1,1]	15
[1,0,1]	20
[1,1,0]	$\bar{20}$
[2,0,0]	20'
[0,0,3]	20''
[0,3,0]	$\bar{20}''$

Table 7. $\mathfrak{so}(6)$ irreducible representations [9].

Dynkin label	Dimension
[0,0]	1
[0,1]	4
[1,0]	5
[0,2]	10
[2,0]	14
[1,1]	16

Table 8. $\mathfrak{so}(5)$ irreducible representations [9].

Dynkin label	Dimension
[0,0]	1
[1,0]	2
[0,1]	$\bar{2}$
[2,0]	3
[0,2]	$\bar{3}$
[1,1]	4
[4,0]	5
[0,4]	$\bar{5}$
[1,2]	6
[2,1]	$\bar{6}$

Table 9. $\mathfrak{so}(4)$ irreducible representations [9].

B Projection matrices for branching rules

Here we list the projection matrices for the branching rules we used to obtain both the Lorentz component contents of minimal scalar superfields and (1, 0) superfields from 9D to 5D.

B.1 Minimal scalar superfield decompositions

The relevant branching rules for decomposing minimal scalar superfields are $\mathfrak{su}(d) \supset \mathfrak{so}(D)$, where d is the number of real components of Grassman coordinates and D is the space-time dimension.

For 9D,

$$\begin{aligned}
 P_{\mathfrak{su}(16) \supset \mathfrak{so}(9)} &= P_{\mathfrak{so}(10) \supset \mathfrak{so}(9)} P_{\mathfrak{su}(16) \supset \mathfrak{so}(10)} \\
 &= \begin{pmatrix} 0 & 0 & 0 & 0 & 1 & 0 & 1 & 0 & 1 & 0 & 1 & 0 & 0 & 0 & 0 \\ 0 & 0 & 1 & 2 & 1 & 1 & 0 & 0 & 0 & 1 & 1 & 2 & 1 & 0 & 0 \\ 0 & 1 & 0 & 0 & 0 & 0 & 1 & 2 & 1 & 0 & 0 & 0 & 0 & 1 & 0 \\ 1 & 0 & 1 & 0 & 1 & 2 & 1 & 0 & 1 & 2 & 1 & 0 & 1 & 0 & 1 \end{pmatrix}. \tag{B.1}
 \end{aligned}$$

For 8D,

$$\begin{aligned}
 P_{\mathfrak{su}(16) \supset \mathfrak{so}(8)} &= P_{\mathfrak{so}(9) \supset \mathfrak{so}(8)} P_{\mathfrak{so}(10) \supset \mathfrak{so}(9)} P_{\mathfrak{su}(16) \supset \mathfrak{so}(10)} \\
 &= \begin{pmatrix} 0 & 1 & 0 & 0 & 0 & 0 & 1 & 2 & 1 & 0 & 0 & 0 & 0 & 1 & 0 \\ 0 & 0 & 1 & 2 & 1 & 1 & 0 & 0 & 0 & 1 & 1 & 2 & 1 & 0 & 0 \\ 0 & 0 & 0 & 0 & 1 & 0 & 1 & 0 & 1 & 0 & 1 & 0 & 0 & 0 & 0 \\ -1 & -2 & -3 & -4 & -4 & -4 & -4 & -4 & -4 & -4 & -4 & -4 & -3 & -2 & -1 \end{pmatrix}. \tag{B.2}
 \end{aligned}$$

For 7D,

$$\begin{aligned}
 P_{\mathfrak{su}(16) \supset \mathfrak{so}(7)} &= P_{\mathfrak{so}(8) \supset \mathfrak{so}(7)} P_{\mathfrak{so}(9) \supset \mathfrak{so}(8)} P_{\mathfrak{so}(10) \supset \mathfrak{so}(9)} P_{\mathfrak{su}(16) \supset \mathfrak{so}(10)} \\
 &= \begin{pmatrix} 0 & 1 & 0 & 0 & 0 & 0 & 1 & 2 & 1 & 0 & 0 & 0 & 0 & 1 & 0 \\ 0 & 0 & 1 & 2 & 1 & 1 & 0 & 0 & 0 & 1 & 1 & 2 & 1 & 0 & 0 \\ -1 & -2 & -3 & -4 & -3 & -4 & -3 & -4 & -3 & -4 & -3 & -4 & -3 & -2 & -1 \end{pmatrix}. \tag{B.3}
 \end{aligned}$$

For 6D,

$$\begin{aligned}
 P_{\mathfrak{su}(8) \supset \mathfrak{so}(6)} &= P_{\mathfrak{so}(7) \supset \mathfrak{so}(6)} P_{\mathfrak{so}(8) \supset \mathfrak{so}(7)} P_{\mathfrak{su}(8) \supset \mathfrak{so}(8)}^{(\text{spinor})} \\
 &= \begin{pmatrix} 0 & 1 & 0 & 0 & 0 & 1 & 0 \\ 0 & 0 & 1 & 0 & 1 & 0 & 0 \\ -1 & -2 & -2 & -2 & -2 & -2 & -1 \end{pmatrix}. \tag{B.4}
 \end{aligned}$$

For 5D,

$$\begin{aligned}
 P_{\mathfrak{su}(8) \supset \mathfrak{so}(5)} &= P_{\mathfrak{so}(6) \supset \mathfrak{so}(5)} P_{\mathfrak{so}(7) \supset \mathfrak{so}(6)} P_{\mathfrak{so}(8) \supset \mathfrak{so}(7)} P_{\mathfrak{su}(8) \supset \mathfrak{so}(8)}^{(\text{spinor})} \\
 &= \begin{pmatrix} 0 & 1 & 0 & 0 & 0 & 1 & 0 \\ -1 & -2 & -1 & -2 & -1 & -2 & -1 \end{pmatrix}. \tag{B.5}
 \end{aligned}$$

For 4D,

$$P_{\mathfrak{su}(4) \supset \mathfrak{so}(4)}^{(\text{spinor})} = \begin{pmatrix} 0 & 1 & 0 \\ 1 & 1 & 1 \end{pmatrix}. \tag{B.6}$$

We will discuss $P_{\mathfrak{su}(8) \supset \mathfrak{so}(8)}^{(\text{spinor})}$ and $P_{\mathfrak{su}(4) \supset \mathfrak{so}(4)}^{(\text{spinor})}$ in the section B.3.

B.2 (1, 0) superfield decompositions

For 8D, 7D, 6D and 5D, the dimensions of the spinor representations in $\mathfrak{so}(D)$ are one-halves of the numbers of real components of Grassman coordinates d . Therefore, we could write down the component contents of the (1, 0) superfields by utilizing the branching rules $\mathfrak{su}(\frac{d}{2}) \supset \mathfrak{so}(D)$.

For 8D,

$$P_{\mathfrak{su}(8) \supset \mathfrak{so}(8)}^{(\text{spinor})} = \begin{pmatrix} 0 & 0 & 1 & 0 & 1 & 0 & 0 \\ 0 & 1 & 0 & 0 & 0 & 1 & 0 \\ 0 & 0 & 1 & 2 & 1 & 0 & 0 \\ 1 & 0 & 0 & 0 & 0 & 0 & 1 \end{pmatrix}. \tag{B.7}$$

For 7D,

$$\begin{aligned}
 P_{\mathfrak{su}(8) \supset \mathfrak{so}(7)} &= P_{\mathfrak{so}(8) \supset \mathfrak{so}(7)} P_{\mathfrak{su}(8) \supset \mathfrak{so}(8)}^{(\text{spinor})} \\
 &= \begin{pmatrix} 0 & 0 & 1 & 0 & 1 & 0 & 0 \\ 0 & 1 & 0 & 0 & 0 & 1 & 0 \\ 1 & 0 & 1 & 2 & 1 & 0 & 1 \end{pmatrix}.
 \end{aligned} \tag{B.8}$$

For 6D,

$$P_{\mathfrak{su}(4) \supset \mathfrak{so}(6)} = \begin{pmatrix} 0 & 1 & 0 \\ 1 & 0 & 0 \\ 0 & 0 & 1 \end{pmatrix}. \tag{B.9}$$

For 5D,

$$P_{\mathfrak{su}(4) \supset \mathfrak{so}(5)} = \begin{pmatrix} 0 & 1 & 0 \\ 1 & 0 & 1 \end{pmatrix}. \tag{B.10}$$

B.3 A note on the projection matrices of $\mathfrak{su}(8) \supset \mathfrak{so}(8)$ and $\mathfrak{su}(4) \supset \mathfrak{so}(4)$

Speaking of the projection matrix for $\mathfrak{su}(8) \supset \mathfrak{so}(8)$, one may recall our discussions on translating $\mathfrak{so}(8)$ Dynkin labels to BYTs in section 4.3. In equation (4.1), we have such an expression for the projection matrix,

$$P_{\mathfrak{su}(8) \supset \mathfrak{so}(8)}^{(\text{vector})} = \begin{pmatrix} 1 & 0 & 0 & 0 & 0 & 0 & 1 \\ 0 & 1 & 0 & 0 & 0 & 1 & 0 \\ 0 & 0 & 1 & 0 & 1 & 0 & 0 \\ 0 & 0 & 1 & 2 & 1 & 0 & 0 \end{pmatrix}, \tag{B.11}$$

which is different than that in equation (B.7) above. Similarly, the projection matrix for $\mathfrak{su}(4) \supset \mathfrak{so}(4)$ for BYTs in equation (8.1) in section 8.3 is

$$P_{\mathfrak{su}(4) \supset \mathfrak{so}(4)}^{(\text{vector})} = \begin{pmatrix} 1 & 0 & 1 \\ 1 & 2 & 1 \end{pmatrix}, \tag{B.12}$$

which also differs with that in equation (B.6). Note that we put the superscripts (vector) and (spinor) for these two projection matrices. The reasons are as follows.

Recall the definition of a projection matrix $P_{\mathfrak{g} \supset \mathfrak{h}}$,

$$v_{\mathfrak{h}}^T = P_{\mathfrak{g} \supset \mathfrak{h}} w_{\mathfrak{g}}^T, \tag{B.13}$$

where $w_{\mathfrak{g}}$ and $v_{\mathfrak{h}}$ are weight vectors in \mathfrak{g} and \mathfrak{h} respectively. In the discussion of $\mathfrak{so}(8)$ BYTs, we want the fundamental representation $\{8\}$ in $\mathfrak{su}(8)$ projected to the vector in $\mathfrak{so}(8)$, i.e.

$$\{8\} = [1, 0, 0, 0, 0, 0, 0] \longrightarrow \{8_v\} = [1, 0, 0, 0], \tag{B.14}$$

hence we call it $P_{\mathfrak{su}(8) \supset \mathfrak{so}(8)}^{(\text{vector})}$. In the discussion of the 8D (1,0) superfield decompositions though, we want the $\{8\}$ in $\mathfrak{su}(8)$ to correspond to the $\{8_s\}$ spinor in $\mathfrak{so}(8)$, i.e.

$$\{8\} = [1, 0, 0, 0, 0, 0, 0] \longrightarrow \{8_s\} = [0, 0, 0, 1], \tag{B.15}$$

hence we call it $P_{\mathfrak{su}(8) \supset \mathfrak{so}(8)}^{(\text{spinor})}$. One quick way to distinguish between two projection matrices is to look at their first column — if it is $[1, 0, 0, 0]^T$ then it is (vector), and if it is $[0, 0, 0, 1]^T$ then it is (spinor).

Similarly, in the discussion of $\mathfrak{so}(4)$ BYTs, we project the fundamental representation $\{4\}$ in $\mathfrak{su}(4)$ to the vector in $\mathfrak{so}(4)$, i.e.

$$\{4\} = [1, 0, 0] \longrightarrow \{4\} = [1, 1], \tag{B.16}$$

then we obtain $P_{\mathfrak{su}(4) \supset \mathfrak{so}(4)}^{(\text{vector})}$. In decomposing the superfield components though, we project the $\{4\}$ to the spinor representation $\{4\} = \{2\} \oplus \{\bar{2}\}$ in $\mathfrak{so}(4)$, i.e.

$$\{4\} = [1, 0, 0] \longrightarrow \{4\} = \{2\} \oplus \{\bar{2}\} = [1, 0] \oplus [0, 1], \tag{B.17}$$

then we get $P_{\mathfrak{su}(4) \supset \mathfrak{so}(4)}^{(\text{spinor})}$.

We conclude by saying that the coincidence of both vector and spinor having d.o.f. = 8 in 8D, or the triality of $\mathfrak{so}(8)$, creates the opportunity of writing two $P_{\mathfrak{su}(8) \supset \mathfrak{so}(8)}$ matrices while we think of them as descending from the same fundamental irrep $\{8\}$ in $\mathfrak{su}(8)$, since there is no vectorial / spinorial distinction of irreps in $\mathfrak{su}(8)$. The same is true for $\mathfrak{su}(4) \supset \mathfrak{so}(4)$, as both vector and spinor in 4D have a total number of 4 components. Therefore, two versions of $P_{\mathfrak{su}(8) \supset \mathfrak{so}(8)}$ serve two different purposes, and so do the two versions of $P_{\mathfrak{su}(4) \supset \mathfrak{so}(4)}$, and there is no contradiction.

B.4 A note on isomorphisms

In [9] and [10], the discussions or the programming tools for calculations of some particular algebras such as $\mathfrak{so}(6)$, $\mathfrak{so}(5)$ and $\mathfrak{so}(4)$ are absent. This is because they are isomorphic to some other simple lie algebras,

$$\mathfrak{so}(6) \cong \mathfrak{su}(4), \tag{B.18}$$

$$\mathfrak{so}(5) \cong \mathfrak{usp}(4), \tag{B.19}$$

$$\mathfrak{so}(4) \cong \mathfrak{su}(2) \times \mathfrak{su}(2). \tag{B.20}$$

In particular, the representations of two isomorphic algebras should have 1-1 correspondences.

$$\begin{array}{l} \mathfrak{so}(6) \cong \mathfrak{su}(4) \\ [a, b, c] \cong [b, a, c] \end{array} \tag{B.21}$$

$$\begin{array}{l} \mathfrak{so}(5) \cong \mathfrak{usp}(4) \\ [a, b] \cong [b, a] \end{array} \tag{B.22}$$

$$\begin{array}{l} \mathfrak{so}(4) \cong \mathfrak{su}(2) \times \mathfrak{su}(2) \\ [a, b] \cong [a] \times [b] \end{array} \tag{B.23}$$

Their Weyl dimension formulas, weight systems for each pair of isomorphic representations, and etc. are exactly the same with the appropriate changes in Dynkin labels. Two

isomorphic algebras are subalgebras of each other. Therefore, it does not hurt to define the following projection matrices,

$$P_{\mathfrak{so}(6) \supset \mathfrak{su}(4)} = P_{\mathfrak{su}(4) \supset \mathfrak{so}(6)} = \begin{pmatrix} 0 & 1 & 0 \\ 1 & 0 & 0 \\ 0 & 0 & 1 \end{pmatrix}, \quad (\text{B.24})$$

$$P_{\mathfrak{so}(5) \supset \mathfrak{usp}(4)} = P_{\mathfrak{usp}(4) \supset \mathfrak{so}(5)} = \begin{pmatrix} 0 & 1 \\ 1 & 0 \end{pmatrix}, \quad (\text{B.25})$$

$$P_{\mathfrak{so}(4) \supset \mathfrak{su}(2) \times \mathfrak{su}(2)} = P_{\mathfrak{su}(2) \times \mathfrak{su}(2) \supset \mathfrak{so}(4)} = \begin{pmatrix} 1 & 0 \\ 0 & 1 \end{pmatrix}, \quad (\text{B.26})$$

which helps us translate between Dynkin labels of isomorphic algebras.

Open Access. This article is distributed under the terms of the Creative Commons Attribution License ([CC-BY 4.0](https://creativecommons.org/licenses/by/4.0/)), which permits any use, distribution and reproduction in any medium, provided the original author(s) and source are credited.

References

- [1] S. James Gates Jr., Y. Hu and S.N.H. Mak, *Superfield Component Decompositions and the Scan for Prepotential Supermultiplets in 10D Superspaces*, *JHEP* **02** (2020) 176 [[arXiv:1911.00807](https://arxiv.org/abs/1911.00807)] [[INSPIRE](#)].
- [2] S. James Gates Jr., Y. Hu and S.N.H. Mak, *Adinkra foundation of component decomposition and the scan for superconformal multiplets in 11D, $\mathcal{N} = 1$ superspace*, *JHEP* **09** (2020) 089 [[arXiv:2002.08502](https://arxiv.org/abs/2002.08502)] [[INSPIRE](#)].
- [3] S.J. Gates Jr., Y. Hu and S.N.H. Mak, *Advening to Adynkrafields: Young Tableaux to Component Fields of the 10D, $N = 1$ Scalar Superfield*, [arXiv:2006.03609](https://arxiv.org/abs/2006.03609) [[INSPIRE](#)].
- [4] M. Faux and S.J. Gates Jr., *Adinkras: A graphical technology for supersymmetric representation theory*, *Phys. Rev. D* **71** (2005) 065002 [[hep-th/0408004](https://arxiv.org/abs/hep-th/0408004)] [[INSPIRE](#)].
- [5] R. Slansky, *Group Theory for Unified Model Building*, *Phys. Rept.* **79** (1981) 1 [[INSPIRE](#)].
- [6] H. Georgi, *Lie Algebras In Particle Physics: from Isospin To Unified Theories (Frontiers in Physics)*, Westview Press (1999), ISBN-10: 0738202339, ISBN-13: 978-0738202334.
- [7] A. Salam and J.A. Strathdee, *Supergauge Transformations*, *Nucl. Phys. B* **76** (1974) 477 [[INSPIRE](#)].
- [8] M. Cederwall, U. Gran, M. Nielsen and B.E.W. Nilsson, *Manifestly supersymmetric M-theory*, *JHEP* **10** (2000) 041 [[hep-th/0007035](https://arxiv.org/abs/hep-th/0007035)] [[INSPIRE](#)].
- [9] N. Yamatsu, *Finite-Dimensional Lie Algebras and Their Representations for Unified Model Building*, [arXiv:1511.08771](https://arxiv.org/abs/1511.08771) [[INSPIRE](#)].
- [10] R.M. Fonseca, *Calculating the renormalisation group equations of a SUSY model with Susyno*, *Comput. Phys. Commun.* **183** (2012) 2298 [[arXiv:1106.5016](https://arxiv.org/abs/1106.5016)] [[INSPIRE](#)].
- [11] R. Feger and T.W. Kephart, *LieART — A Mathematica application for Lie algebras and representation theory*, *Comput. Phys. Commun.* **192** (2015) 166 [[arXiv:1206.6379](https://arxiv.org/abs/1206.6379)] [[INSPIRE](#)].
- [12] M. Rausch de Traubenberg, *Clifford algebras in physics*, [hep-th/0506011](https://arxiv.org/abs/hep-th/0506011) [[INSPIRE](#)].
- [13] S.J. Gates Jr., Y. Hu and S.N.H. Mak, *Weyl covariance, and proposals for superconformal prepotentials in 10D superspaces*, *JHEP* **03** (2021) 074 [[arXiv:2007.05097](https://arxiv.org/abs/2007.05097)] [[INSPIRE](#)].