

OMNIPOWER direct and CT meters

Technical Description



Contents

1	Disclaimer	7
1.1	Copyright information	7
1.2	Third parties	7
2	Introduction to OMNIPOWER	8
3	Technical specification	9
3.1	Electrical specifications.....	9
3.1.1	Technical Data for OMNIPOWER direct meters.....	10
3.1.2	Technical Data for OMNIPOWER CT meters	11
3.2	Mechanical specifications.....	12
3.3	Type number overview	14
3.4	Approvals.....	14
3.5	Connection diagrams.....	15
3.6	Terminal numbering	17
4	How to use OMNIPOWER meters	19
4.1	Installation and power-up	19
4.2	Power-up/Start-up sequence	19
4.2.1	Display functions	20
4.2.2	Push-button functionalities	20
4.2.3	Tamper	21
4.2.4	Meter status logger (1.1.99.98.2.255).....	21
4.3	Time management.....	21
4.3.1	Backup	21
4.3.2	Hour counters.....	21
4.3.3	Calendar and daylight saving time plan	21
4.3.4	RTC setting and adjustment using pushbutton.....	22
4.3.5	RTC adjustment logger (1.1.99.98.3.255).....	22
4.4	Power and energy measurements.....	23
4.4.1	Power measurements.....	23
4.4.2	Energy registration	24
4.4.3	Calculation methods of an OMNIPOWER three-phase meter	26
4.4.4	Mean power values	28

4.4.5	Peak power values	28
4.4.6	Energy tariff registers	29
4.5	Data loggers.....	31
4.5.1	Load profile (1.1.99.1.0.255)	31
4.5.2	Monthly debiting logger (1.1.98.1.0.255).....	32
4.5.3	Daily/weekly/monthly debiting logger (1.1.98.2.0.255)	33
4.5.4	Analysis logger (1.1.99.1.1.255).....	33
4.6	Meter readout	35
4.6.1	Manual display readout.....	35
4.6.2	9-digit value field	35
4.6.3	Protocols.....	37
4.6.4	Local readout via optical interface – METERTOOL OMNIPOWER.....	38
4.6.5	Integrated OMNICON radio mesh connectivity	38
4.6.6	Integrated OMNICON point-to-point connectivity	38
4.6.7	Full encryption on all interfaces	39
4.6.8	M-Bus and RS-485 connectivity.....	39
4.7	Modularity options	39
4.7.1	Primary modules.....	39
4.7.2	CCC modules.....	39
4.8	Disconnect functionality (1.1.128.0.11.255).....	40
4.8.1	Disconnect function in the meter	41
4.8.2	Manual disconnection and reconnection	41
4.8.3	Remote disconnection from a smart metering system	42
4.8.4	Smart disconnect.....	42
4.8.5	Disconnection basis	42
4.8.6	Current-controlled disconnection	42
4.8.7	Power-controlled disconnection.....	42
4.8.8	Delayed disconnection	42
4.8.9	Reconnection.....	43
4.8.10	Overvoltage disconnection	43
4.8.11	Disconnection on meters with APS.....	44

OMNIPOWER direct and CT meters

4.8.12	Event logger for disconnect/connect history (1.1.99.98.5.255)	45
4.8.13	Prepayment	45
4.8.14	Prepayment principle	45
4.9	Power quality measurements	47
4.9.1	Frequency measurements	47
4.9.2	Voltage variations	47
4.9.3	Voltage outage	48
4.9.4	Configuration of power voltage measurements	49
4.9.5	Rapid voltage change	50
4.9.6	Supply voltage unbalance	50
4.9.7	Total harmonic distortion (THD)	51
4.9.8	Readout of the power quality measurements	51
4.9.9	Power factor	53
4.9.10	Neutral fault detection	53
4.10	Other smart grid functionalities	56
4.10.1	Firmware upload	56
4.10.2	Alarm handling/push alarms	56
4.10.3	All phase power outage alarm	56
4.10.4	Control of external load relays	56
4.10.5	Multi-utility options	57
4.10.6	Miscellaneous use	58
4.10.7	Pulse inputs in the module area	58
4.10.8	Examples of pulse input from an electricity meter	59
4.10.9	Pulse outputs in module area	59
4.10.10	S0 output	59
4.10.11	Auxiliary power supply (APS)	60
5	Ordering specification	62
5.1	Meter configuration	62
5.2	Hardware configuration	63
5.3	Software configuration	65
5.4	Display configuration	70
5.5	Tariff control configuration	73

5.6	Load control configuration	73
5.7	Smart disconnect setup	73
5.8	Sealable push-button configuration	73
5.9	1107 protocol configuration.....	73
5.10	Packing.....	74
5.10.1	Box solution	74
5.10.2	Pallet solution	75
5.11	Customer labels	75
5.12	Sealing	76
5.13	Accessories	77

OMNIPOWER direct and CT meters

Revisions history:

Document revision	Description	Meter software revision
A1	First release of the technical description for OMNIPOWER direct meters. Does not include OMNIPOWER CT.	OMNIPOWER direct meters: - SW no: 5098736, rev. B1 → P1
A2	Update of the section with power quality measurements.	OMNIPOWER direct meters: - SW no: 5098736, rev. B1 → P1
A3	Includes OMNIPOWER ST variant. (Symmetric terminals)	OMNIPOWER direct meter: - SW no: 5098736, rev. P1 → P1
B1	Includes OMNIPOWER CT	OMNIPOWER direct meters: - SW no: 5098736, rev. Q1 OMNIPOWER CT meter: - SW no: 50981040, rev. Q1
C1	Includes new overvoltage disconnect functionality.	OMNIPOWER direct meters: - SW no: 5098736, rev. R1, S1, T1, U1 OMNIPOWER CT meter: - SW no: 50981040, rev. R1, S1, T1, U1
D1	Includes new OMNIPOWER variant with Last gasp and encryption.	OMNIPOWER direct meters: - SW no: 5098736, rev. R1, S1, T1, U1 - SW no. 50981173 rev. D1, E1 (No DLMS) - SW no. 50981165 rev. D1 (No DLMS) OMNIPOWER CT meter: - SW no: 50981040, rev. R1, S1, T1, U1

1 Disclaimer

Although the information and recommendations in this document are presented in good faith and believed to be correct, Kamstrup makes no representations or warranties as to the completeness or accuracy of the information.

Information is supplied upon the condition that the persons receiving same will make their own determination as to its suitability for their purposes prior to use. In no event will Kamstrup be responsible for damages of any nature whatsoever resulting from the use of or reliance upon information from this site or the products to which the information refers.

Kamstrup does not warrant the accuracy or timeliness of the information in this document and has no liability for any errors or omissions in the document.

This document is provided on an “as is” basis. No representations or warranties, either express or implied, of merchantability, fitness for a particular purpose or of any other nature are made hereunder with respect to information or the products to which information refers.

1.1 Copyright information

Copyright © Kamstrup A/S
Industrivej 28
Stilling
DK-8660 Skanderborg, Denmark
All Rights Reserved

The graphics and content in this document are the copyrighted work of Kamstrup and contain proprietary trademarks and trade names of the Company. Kamstrup hereby authorizes copying of documents for non-commercial use or for educational research only. The above copyright notice must appear on every such copy. No right or license is granted under any copyright, patent or trademark of Kamstrup to any other party.

1.2 Third parties

This document may contain links to other parties. Kamstrup makes no warranty or representation regarding any linked information appearing therein. Such links do not constitute an endorsement by Kamstrup of any such information and are provided only as a convenience. Kamstrup is not responsible for the content or links displayed by third parties.

2 Introduction to OMNIPOWER

Kamstrup OMNIPOWER meters are prepared for the future demands, required by smart grid implementations. It provides a detailed insight into consumption patterns at the low-voltage part of the power grid and is also a grid sensor for collection of relevant power quality information. OMNIPOWER offers a list of features e.g.:

- Optimized functionalities for smart metering systems
- Communication for smart home applications
- Security against tampering
- Ultra-low power consumption
- Remote firmware update; approved according to WELMEC 7.2.

From the factory, the meter can be configured to measure both imported and exported energy. Measurements are saved in a permanent memory. As default, the OMNIPOWER meter can generate load profiles in all four quadrants. A load profile provides detailed information about consumed and produced energy. An additional logger with 16 channels contains data for analysis purposes.

Part of OMNIA Suite

OMNIPOWER with integrated OMNICON radio communication is an essential part of Kamstrup’s OMNIA Suite all-comprising smart grid platform, shown in the figure, which offers a full line of smart technology, support and knowledge.

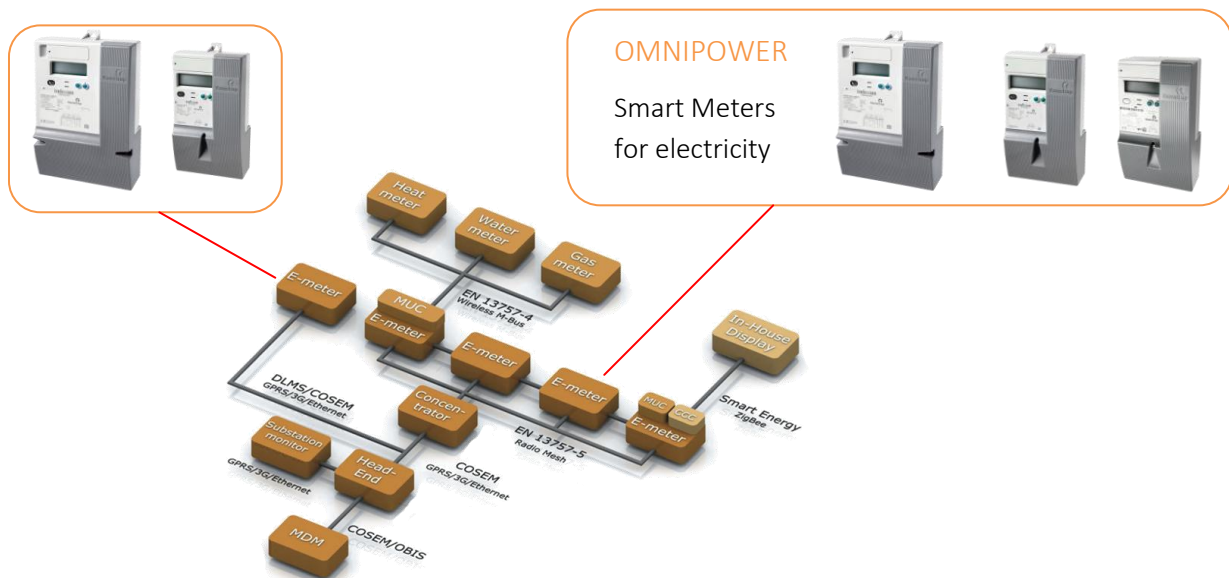

Figure 1: OMNIA Suite overview.

As part of OMNIA Suite, OMNIPOWER can be used as the gateway for collecting other consumption types such as water, gas, heating and cooling. It is also prepared for Home Area Network (HAN) communication via a Consumer Communication Channel (CCC) module which can be inserted by the consumer on the meter front.

3 Technical specification

OMNIPOWER provides a long range of technical and mechanical features with high performance and reliability. The following technical specifications are both valid for OMNIPOWER direct and CT meters.

3.1 Electrical specifications

OMNIPOWER meters are constructed with independent and galvanically separated measuring systems (the number of measuring systems depends on the meter type). This ensures a correct measurement irrespective of how many and which measurement systems are used.

A switch mode supply feeds measuring circuits and the main processor with voltage. Furthermore, the switch mode supply in combination with varistors and power resistors functions as an excellent transient protection.

The use of shunt and switch mode supply also makes sure that OMNIPOWER direct meters are immune to magnetic influence. Measured and calculated data is safely stored in an integrated non-volatile memory (EEPROM).

Technical data:

Nominal frequency, f_n	50 or 60 Hz \pm 5 %
Phase displacement	Unlimited
Data storage	EEPROM; > 10 years without voltage
Display	LCD, 7 mm digit height (value field) LCD, 5 mm digit height (identification readings) LCD, 3 mm digit height (voltage readings)
Real-time clock (RTC)	
Accuracy	Typically 5 ppm at 23°C
Backup battery lifetime	> 10 years at normal operation
Supercap lifetime	> 10 years at normal operation
Supercap backup time	7 days at fully charged

OMNIPOWER direct and CT meters

3.1.1 Technical Data for OMNIPOWER direct meters

Measuring principle:

Current: One-phase current measurement via current shunt
 Voltage: One-phase voltage measurement via voltage divider

Nominal voltage, Un
 3x230 VAC -20 % - +15 % (for Aron meter only)
 1x230 VAC -20 % - +15 %
 2x230/400 VAC -20 % - +15 %
 3x230/400 VAC -20 % - +15 %

Current, Itr - Ib (Imax)

OMNIPOWER three-phase and single-phase meter	
Without breaker	With breaker
0.25-5(60)A	0.25-5(60)A
0.25-5(80)A	0.25-5(80)A
0.25-5(100)A	0.25-5(100)A

Accuracy class,

Active energy MID: Class A, Class B
 IEC: Class 2, Class 1
Reactive energy IEC: Class 3, Class 2

Own consumption (per phase)¹

OMNIPOWER three-phase	Without breaker	With breaker
Current circuit	0.01 VA	0.01 VA
Voltage circuit	0.4 VA	0.4 VA
	0.1 W	0.1 W
OMNIPOWER single-phase	Without breaker	With breaker
Current circuit	0.01 VA	0.01 VA
Voltage circuit	0.6 VA	0.6 VA
	0.2 W	0.2 W

Meter constant 1000 imp/kWh

S0 pulse diode 1000 imp/kWh, kvarh
 Pulse time 30 ms ± 10 %

S0 pulse output 1000 imp/kWh
 Pulse time 30 ms ± 10 %

¹ Measured on phase L1 according to MID type-approval.

3.1.2 Technical Data for OMNIPOWER CT meters

Measuring principle:

Current: One-phase current measurement via current transformers

Voltage: One-phase voltage measurement via voltage divider

Nominal voltage, U_n 3x230 VAC -20 % - +15 % (for Aron meter only)
3x230/400 VAC -20 % - +15 %

Current, I_{min} - I_n (I_{max})

OMNIPOWER CT meter
0.01-1(6)A
0.05-5(6)A

Accuracy class,

Active energy MID: Class B, Class C

IEC: Class 1, Class 0.5

Reactive energy IEC: Class 2

Own consumption (per phase)²

OMNIPOWER CT meter	
Current circuit	0.02 VA
Voltage circuit	0.2 VA
	0.1 W

Meter constant 10000 imp/kWh

S0 pulse diode 10000 imp/kWh, kvarh
Pulse time 30 ms ± 10 %

S0 pulse output 5000 imp/kWh
Pulse time 30 ms ± 10 %

² Measured on phase L1 according to MID type-approval.

OMNIPOWER direct and CT meters

3.2 Mechanical specifications

The meter is designed as a two-piece plastic construction, consisting of housing and meter cover, both made of fire resistant plastic. The housing is constructed in such a way that it protects the metrological functions. It is not possible to open the housing without breaking the metrological seal.

Technical data:

Operating temperature	-40°C - +70°C
Storage temperature	-40 °C - +85 °C
Protection class	IP54
Protection class	II
Relative humidity	< 75 % year's average at 21 °C
☒	< 95 % less than 30 days/year, at 25 °C

Weight

OMNIPOWER	Without breaker	With breaker
Single-phase meter	600g	700g
Three-phase meter	900g	1200g
CT meter	900g	NA

Application area Indoor or outdoor in suitable meter cabinet

Materials Glass reinforced polycarbonate

Dimensions:

The dimensions for the OMNIPOWER meters can be seen in Figure 2 and Figure 3.

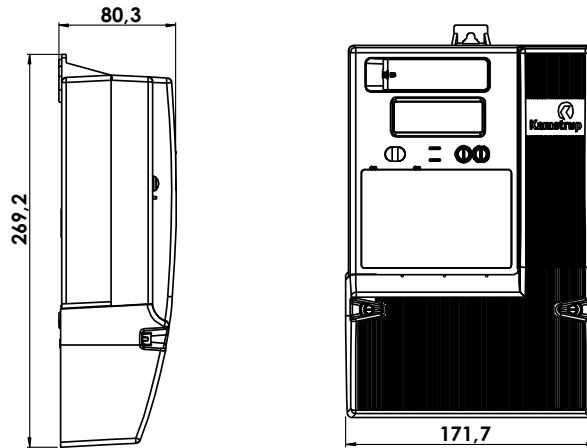

Figure 2: Dimensional sketch of OMNIPOWER CT and three-phase meter with/without breaker.

OMNIPOWER single-phase

OMNIPOWER single-phase ST-meter

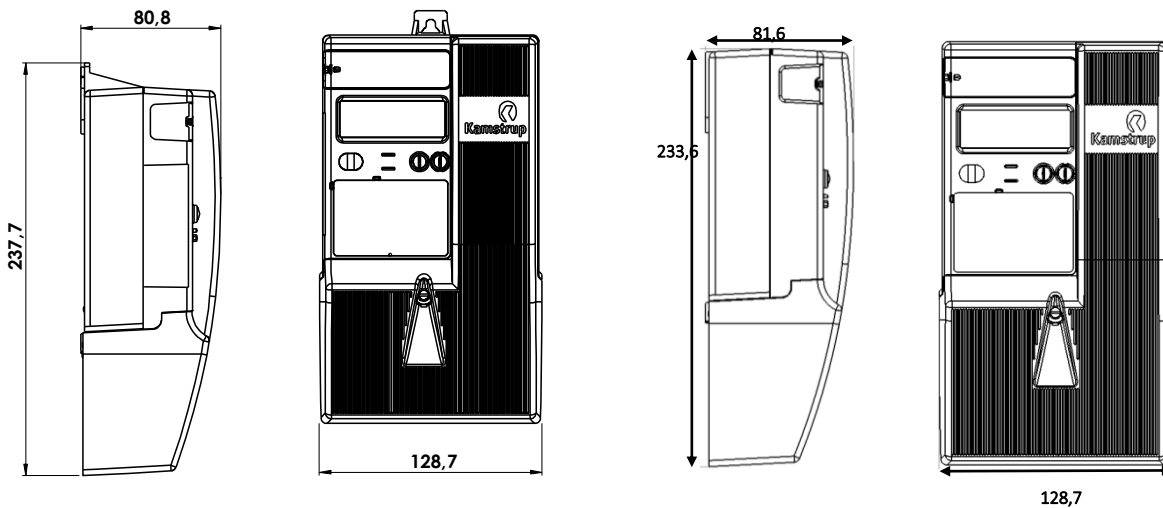

Figure 3: Dimensional sketch of OMNIPOWER single-phase meter with/without breaker.

The meter cover can be ordered with different lengths. A short version allows pre-mounted terminal-pins or wires to be mounted, while the longer version covers the terminal inputs and outputs.

OMNIPOWER direct and CT meters

3.3 Type number overview

OMNIPOWER is available with a range of optional hardware features depending on the application for which they are used. The meters can e.g. be delivered with internal disconnect function for disconnection and connection of the consumer's supply, configured for the measurement of energy in all 4 quadrants, with integrated radio transceiver and auxiliary power supply (APS). The choice between these options defines the meter type number. The type number of OMNIPOWER meters consists of 18 characters that describe the configuration of the meter regarding hardware and mechanical options. The type numbers for the different OMNIPOWER meters have the following structure:

OMNIPOWER Three-phase meter	Three-phase, 4-wire meter	684-1X-3XX-NxX-XXXX-XXX.
OMNIPOWER Three-phase meter	Three-phase, 3-wire meter	684-1X-2XX-NxX-XXXX-XXX.
OMNIPOWER Single-phase meter	Single-phase, 2-wire meter	686-1X-1XX-NxX-XXXX-XXX.
OMNIPOWER CT meter	Three-phase, 4-wire meter	685-11-3XX-DxX-0X11-XXX.
OMNIPOWER CT meter	Three-phase, 3-wire meter	685-11-2XX-DxX-0X11-XXX.

See "Ordering specification", p. 62 for the complete configuration of the OMNIPOWER type number.

3.4 Approvals

OMNIPOWER is type approved according to the Measuring Instruments Directive (MID) for active positive energy and according to the national requirements for other energy types, where required.

Type approval	Norm
<ul style="list-style-type: none">Active energy	EN 50470-1 EN 50470-3
<ul style="list-style-type: none">Reactive energy and active energy	IEC 62052-11 IEC 62053-21 IEC 62053-22 IEC 62053-23
Various	Norm
<ul style="list-style-type: none">Terminal	DIN 43857 BS 7856
<ul style="list-style-type: none">S0 pulse output	DIN 43864
<ul style="list-style-type: none">Optical reading	EN 62056-21 mode C
<ul style="list-style-type: none">OBIS/EDIS codes	IEC 62056-61
<ul style="list-style-type: none">Breaker	EN 62055-31, Annex C

3.5 Connection diagrams

The valid connection diagram appears from the type label on the front of the meter.

OMNIPOWER Three-phase, four-wire (S0)

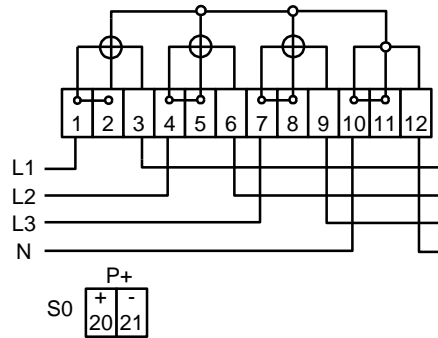

OMNIPOWER Three-phase, four-wire (APS version)

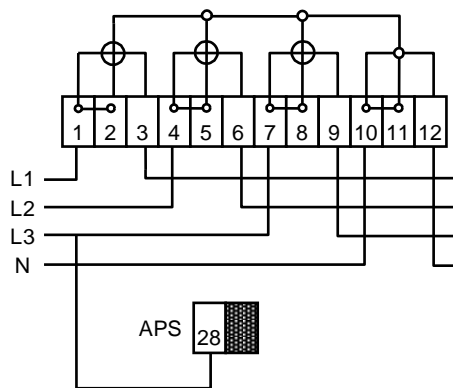

OMNIPOWER Three-phase, three-wire (Aron)

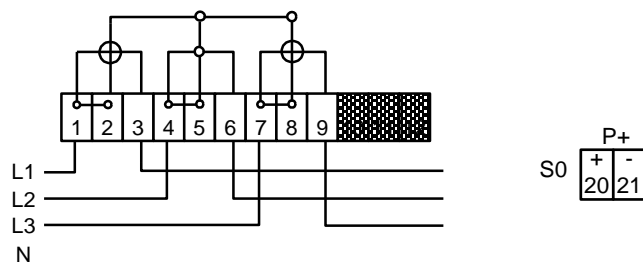

OMNIPOWER direct and CT meters

OMNIPOWER Single-phase, two-wire

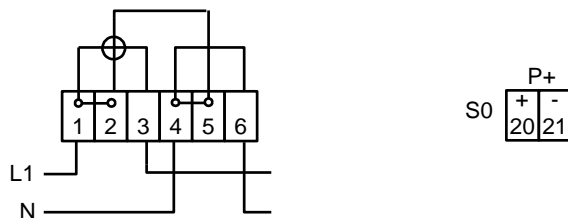

OMNIPOWER Single-phase, two-wire – Symetric terminals – ST-meter

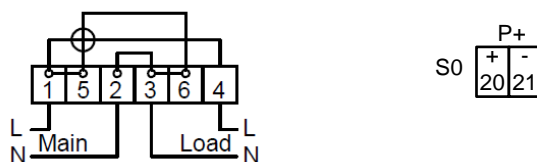

OMNIPOWER CT 3-phase, 4-wire

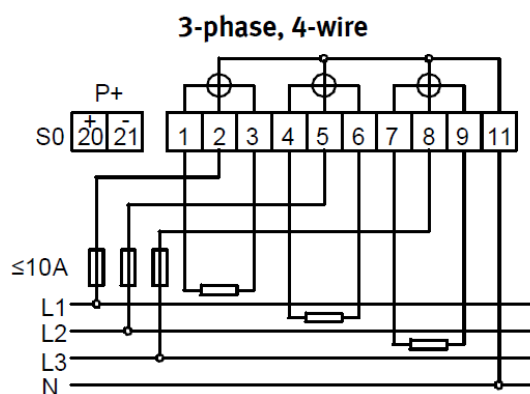

OMNIPOWER CT 3-phase, 3-wire (Aron)

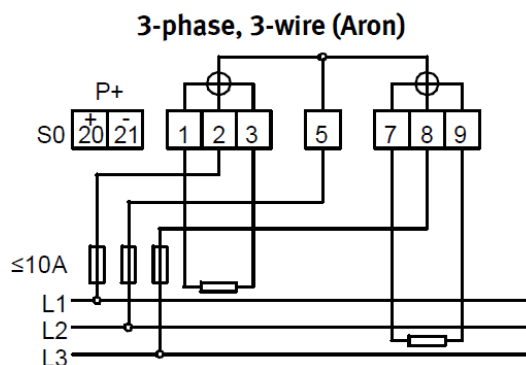

Connect the meter in accordance with the installation diagram on the meter's type label.

3.6 Terminal numbering

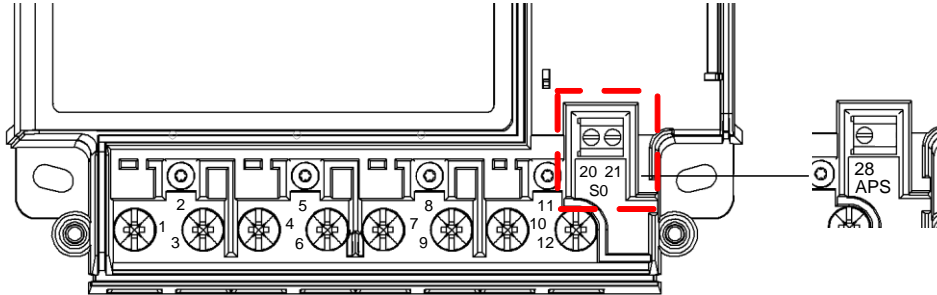

Figure 4: Terminal numbering for OMNIPOWER three-phase meter with S0 or APS.

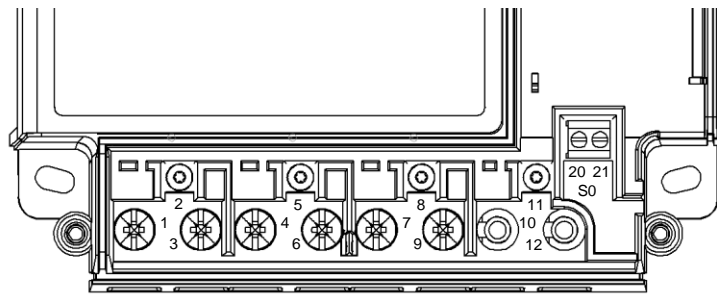

Figure 5: Terminal numbering for OMNIPOWER three-phase meter with S0.

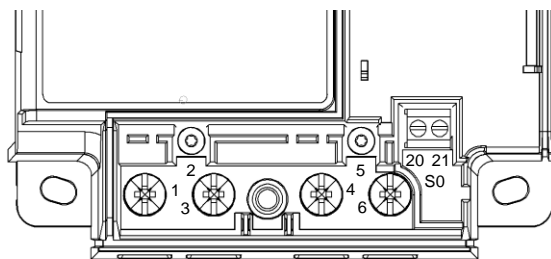

Figure 6: Terminal numbering for OMNIPOWER single-phase meter with S0.

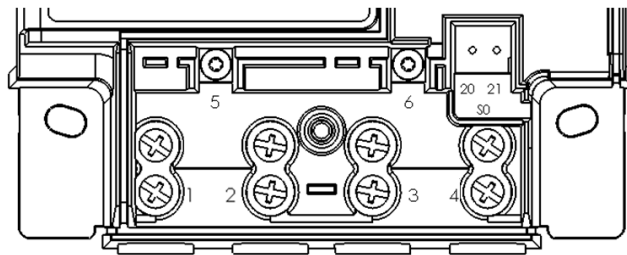

Figure 7: Terminal numbering for OMNIPOWER single-phase ST-meter with S0

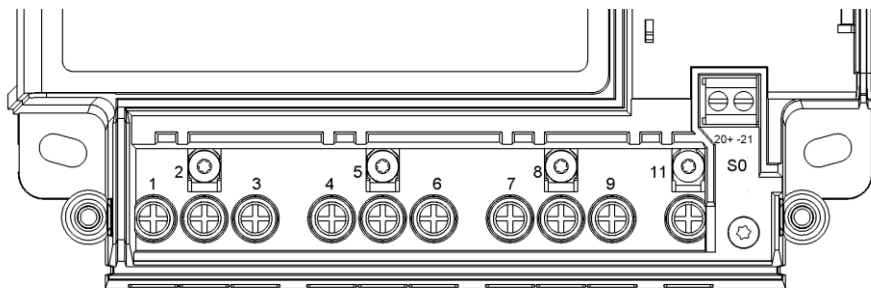

Figure 8: Terminal numbering for OMNIPOWER CT-meter

4 How to use OMNIPOWER meters

This chapter describes in details the use of OMNIPOWER, the features implemented and not least the benefits which the meter provides to the users.

4.1 Installation and power-up

It is essential that the meter is installed and connected as described in Kamstrup installation manuals. See previous section for connection diagrams of the specific meter types.

4.2 Power-up/Start-up sequence

The display power-up sequence is shown in Figure 9.

In the first five seconds after connecting OMNIPOWER, the ROM checksum is displayed with its corresponding OBIS code.

In the next five seconds, the meter shows its software type number and revision number. The value field describes the software number while the software revision is shown in the text field in the upper right corner of the display.

The phase indicators L1, L2 and L3 show whether voltage is applied to each phase. The arrows indicate any direction of the power flow for each phase. Also the phase sequence is indicated. The sequence is defined in Table 1.

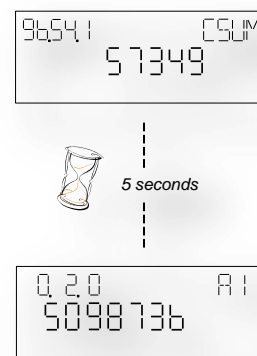

Figure 9: Start-up sequence in display.

Symbol	Phase sequence
	L1-L2-L3
	L1-L3-L2

Table 1: Phase sequence.

After additional 5 seconds, the meter starts operational mode and begins displaying its automatic display list.

If the meter is part of OMNIA Suite, the integrated radio module starts searching for a network. This is indicated by the antenna symbol that flashes. When a network is located and the meter is in contact and recognized by a concentrator, the symbol will be constantly “On”.

It is possible to delay the start up of the integrated radio for 5 minutes if the left push button is pushed for approximately 5 seconds immediately after power is applied to the meter. The RF symbol will turn off to indicate that the start-up is delayed.

The radio will automatically start searching for a radio network when the 5 minutes are passed, or immediately after a re-power of the meter.

OMNIPOWER direct and CT meters

4.2.1 Display functions

The OMNIPOWER provides the possibility for up to four display lists to which a number of meter values/parameters can be attached. Table 2 gives an overview of the available display lists.

Display view	Description	Shifting	Maximum values
Automatic display list	A list of registers that is shown automatically in the display.	Automatically – 10 seconds (fixed)	16
Manual consumer display list	A list of registers that can be seen by pushing the left push-button on the meter front.	Manually – via left push-button	30
Manual utility display list	As manual consumer display list, but this list can only be seen by pushing the sealable push-button.	Manually – via right push-button	16
Supply backup display list	In case the meter is disconnected from the main supply, this display list still allows the user to read out a number of meter values. The display is only activated by pushing the left push-button.	Manually – via left push-button	8

Table 2: Available display lists in OMNIPOWER.

Each list can be customized at ordering, and can also be reconfigured after installation. OMNIA Suite also provides the possibility to update the display lists remotely.

4.2.2 Push-button functionalities

Two push-buttons are available on OMNIPOWER meters as shown in Figure 10. The left push-button is used for manual display scrolling and manual connect/disconnect of internal breakers if the meter is configured for this. The right push-button is sealable, and the following functionalities can be enabled via configuration:

- Set time and date
- Adjust time
- Execute debiting stop
- Disable/enable optical port
- Change meter number
- Set tariff plan and load control plan
- Test load control relays.



Figure 10: OMNIPOWER pushbuttons.

Each function can be enabled independently in the setup. Configuration of the sealable push-button must be done at the time of ordering the meter.

The right push-button can only be activated when the slot is in a vertical position. The button can be locked by turning it 90° to horizontal position and then mount a sealing as shown in Figure 11.



Figure 11: Release of sealable pushbutton.

4.2.3 Tamper

An OMNIPOWER meter has registration of magnetic field detection and meter cover tampering. Any registration can be accompanied by indication in the display. This indication can be configurable to be temporary (i.e. it disappears when the source to tamper disappears), or permanent until a tamper release command is received either from a smart metering system or by activating the sealable push-button.

With OMNIPOWER meters implemented in OMNIA Suite, it is also possible to receive tamper registrations as push alarms to the meter data management (MDM) system.

4.2.4 Meter status logger (1.1.99.98.2.255)

The meter has a status logger which contains information about the meters status events. A registration in the logger can be triggered by following events:

- EEPROM access failure
- ROM checksum fail
- Tamper detection
- Magnetic field detection
- Meter reset

The meter status logger is circular and will therefore contain the 200 newest meter status events.

4.3 Time management

The meter has an integrated real-time clock (RTC) to provide measured data with an accurate time stamp (typically 5 ppm at 23 °C). The RTC is used to generate time stamps on load profile values and event registrations and to keep any tariff and load control plans on track.

4.3.1 Backup

In case of power supply outage, the RTC function is supplied by either a battery or rechargeable backup unit (supercap). The backup time of the battery depends on the period of time the meter is without mains supply, and in addition, the battery gives access to further functions such as display views despite lack of mains supply.

The lifetime of the backup unit also depends on the mains voltage supply to the meter and the ambient temperature.

4.3.2 Hour counters

As the RTC manage the date and time in the meter, an hour counter register manages the number of operating hours of the meter, i.e. number of hours where main voltage are supplied to the meter.

As a supplement to the total hour counter, the meter also contains separate counters for all 8 tariffs available in the meter.

4.3.3 Calendar and daylight saving time plan

It is possible to set up a calendar plan useable for tariff and load control. The calendar plan can contain up to 4 different seasons, and each season can have different weekly plans. How a weekly plan is divided into working days, non-working days and holidays is described in "Internal tariff plan in the meter", p. 29.

OMNIPOWER direct and CT meters

In addition to the “regular” calendar plan, a list of exceptions days can be added to the calendar. The list can contain up to 200 days 20 years ahead in time. Exceptions days will have the same tariff plan as holidays.

Finally, OMNIPOWER also have an option for a daylight saving time plan which can be programmed in the meter with corresponding configuration of start and end dates for up to 20 years ahead in time. However, all time stamps in data loggers and event loggers are done in normal time and does not take eventually daylight light saving time into account.

4.3.4 RTC setting and adjustment using pushbutton

It is possible to configure the meter to enable RTC setting/adjustment using the right pushbutton. The guideline on how to do this is described in 5514xxxx.

4.3.5 RTC adjustment logger (1.1.99.98.3.255)

The time is adjustable via the configuration program METERTOOL or via a smart metering system like OMNIA Suite. Changes are registred in a dedicated RTC adjustment logger, and if needed, the registration can be filtered to avoid insignifcant adjustments, e.g. less than 7 seconds, to fill the log.

4.4 Power and energy measurements

Energy consumption is calculated as an expression of the current compared to the phase voltage and time. The energy registration per measuring system is communicated to the meter's legal processor via the meter's own internal bus system and is summed in the meter's main registers.

4.4.1 Power measurements

OMNIPOWER are constructed as 4-quadrant meters, which means active, reactive and apparent power and energy measurements in the flow directions shown in Figure 12.

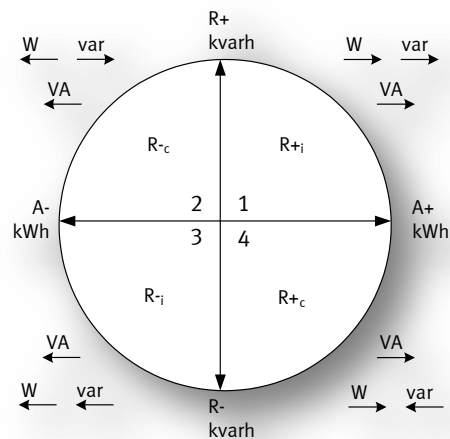

Figure 12: Energy and power measurement in 4 quadrants.

The available power registers in OMNIPOWER are listed in Table 3 with the corresponding OBIS codes according to EN 62056-61.

Designation	Quadrant illustration	Description	Unit	Display OBIS code
P+ P14		Active positive power consists of active power from quadrants 1 and 4.	kW	1.7.0
P- P23		Active negative power consists of active power from quadrants 2 and 3.	kW	2.7.0
Q+ Q12		Reactive positive power consists of positive inductive power from quadrant 1 and positive capacitive power from quadrant 2.	kvar	3.7.0
Q- Q34		Reactive negative power consists of negative inductive power from quadrant 3 and negative capacitive power from quadrant 4.	kvar	4.7.0
S+ S14		Positive apparent power from quadrant 1 and 4.	kVA	9.7.0
S- S23		Negative apparent power from quadrant 2 and 3.	kVA	10.7.0

Table 3: Main power registers in OMNIPOWER.

OMNIPOWER direct and CT meters

All values in Table 3 are instantaneous values. They have an update frequency of 1 Hz. Additional to these instantaneous power registers, OMNIPOWER also contains a range of derived power registers, e.g. mean values and peak values. These different values are described in section 4.4.4 and 4.4.5.

4.4.2 Energy registration

The OMNIPOWER is available as an import/export meter for active, reactive and apparent energy. The possible energy registers are described in Table 4 with the corresponding OBIS code according to EN 62056-61.











Designation	Quadrant illustration	Description	Unit	Display OBIS code ³
A+ A14		Active positive energy consists of active energy from quadrants 1 and 4.	kWh	1.8.0 1.8.x (tariff)
A- A23		Active negative energy consists of active energy from quadrants 2 and 3.	kWh	2.8.0 2.8.x (tariff)
R+ R12		Reactive positive energy consists of positive inductive energy from quadrant 1 and positive capacitive energy from quadrant 2.	kvarh	3.8.0 3.8.x (tariff)
R- R34		Reactive negative energy consists of negative inductive energy from quadrant 3 and negative capacitive energy from quadrant 4.	kvarh	4.8.0 4.8.x (tariff)
R1 R+ _i		Positive inductive energy from quadrant 1.	kvarh	5.8.0
R2 R+ _c		Positive capacitive energy from quadrant 2.	kvarh	6.8.0
R3 R- _i		Negative inductive energy from quadrant 3.	kvarh	7.8.0
R4 R- _c		Negative capacitive energy from quadrant 4.	kvarh	8.8.0
E+ E14		Positive apparent energy from quadrant 1 and 4.	kVAh	9.8.0 9.8.x (tariff)
E- E23		Negative apparent energy from quadrant 2 and 3.	kVAh	10.8.0 10.8.x (tariff)

Table 4: Main energy registers in OMNIPOWER.

Some of the energy registers in the table are used as the legal energy registration in OMNIPOWER. Configuration of the meter decides which energy registers to be legal.

³ The x indicates the corresponding tariff for the energy type.

The legal energy registers are automatically used as values for the load profile data logger, which is described in detail in “Load profile”, p. 31.

In addition to energy registers a number of deviated energy registers are also available in the meter. These are listed in Table 5.

For OMNIPOWER CT meters registers 1.8.x, 2.8.x, 3.8.x, 4.8.x, 5.8.0 and 8.8.0 are available as both secondary and primary values. The secondary values can be configured for use in display and load profile logger.

Designation	Description	Unit	Display OBIS code
A1234	This register sums the active positive and negative energy numerically. Can be used as a control register for a one-way (A+) meter.	kWh	1.15.8
A+ trip	Resettable trip counter. Accumulates total active positive energy and resets via left push button (6 sec).	kWh	1.1.128
A- Trip	Resettable trip counter. Accumulates total active positive energy and resets via left push button (6 sec).	kWh	2.1.128
R+ trip	Resettable trip counter. Accumulates total active positive energy and resets via left push button (6 sec).	kvarh	3.1.128
R- Trip	Resettable trip counter. Accumulates total active positive energy and resets via left push button (6 sec).	kvarh	4.1.128
E+ trip	Resettable trip counter. Accumulates total apparent positive energy and resets via left push button (6 sec).	kVAh	9.1.128
E- Trip	Resettable trip counter. Accumulates total apparent negative energy and resets via left push button (6 sec).	kVAh	10.1.128
A-net = A+ - A-	Net calculation register. Counts backwards if A- > A+ . The register is useable as infomative register in the display, for installations with microgeneration, e.g. solar cells. The register is not available as a legal register in the load profile logger.	kWh	1.16.8
A ⁴ _{prepayment}	Prepayment register that counts down the kWh value which is preset in the register. Used to disconnect the internal breaker when it reaches zero.	kWh	0.130.0
A ⁴ _{prepayment,credit}	Used as a credit register in case the exception time is active in the prepayment functionality. Can only be reset by adding kWhs to the meter.	kWh	0.130.1

Table 5: Additional energy registers in OMNIPOWER.

⁴ Register is Not available in OMNIPOWER CT meters.

OMNIPOWER direct and CT meters

The resolution by which all the energy readings are shown in the display can be set to following:

Display resolution	Single-phase and three-phase meters	CT meters
6.1 (000000.0) kWh/kvarh	✓	-
6.3 (000000.000) kWh/kvarh	✓	-
7.0 (0000000) kWh/kvarh	✓	✓
7.1 (0000000.0) kWh/kvarh	-	✓
7.2 (0000000.00) kWh/kvarh	✓	✓

Table 6: Resolution for energy registers in OMNIPOWER.

Furthermore, it is possible to select or deselect leading zeroes. The configuration of the display resolution and leading zeros are done when ordering the meter and cannot be reconfigured afterwards due to legal requirements.

Alle secondary energy registers in OMNIPOWER CT are shown with display resolution 5.2 (00000.00) kWh/kvarh.

4.4.3 Calculation methods of an OMNIPOWER three-phase meter

OMNIPOWER provides three methods for calculating the energy in three-phase meters. Three similar meters can therefore obtain different results for energy measurement depending on the configuration of calculation method.

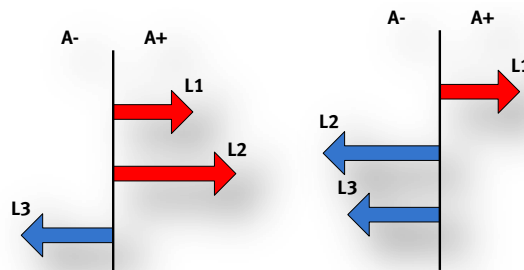

Figure 13: Two examples of energy consumption in a three-phase meter.

If energy is imported on phases L1 and L2 (shown as red), and energy is exported on phase L3 (shown as blue) as shown to the left in Figure 13, the calculation can be made according to the methods described below.

Table 7 describes the different calculation methods of the total energy dependent on the applied calculation method.

Calculation method	Three-phase examples		Description
	Phase energy consumption	Total energy registration	
Individual import/export			Individual import/export calculation method has one register for the positive contributions and one for the negative contributions.
			
Vector summation			When using vector summation, the positive contributions are added and the negative contributions are subtracted in the same way as by electromechanical meters. Contributions from e.g. solar energy installations will be set off in the total energy calculation. This calculation method is sensitive to incorrect installation and manipulation.
			
Total summation			Total summation adds all contributions to the positive register whether one or more phases contributes with negative energy.
			

Table 7: Calculation methods in OMNIPOWER.

The configuration of the energy calculation method must be done when ordering the meter and **cannot** be reconfigured afterwards due to legal requirements.

OMNIPOWER direct and CT meters

4.4.4 Mean power values

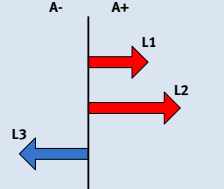
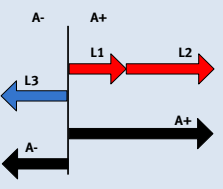
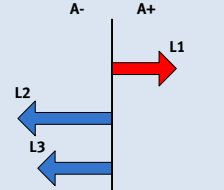
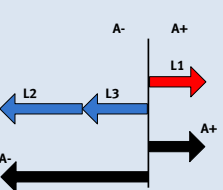
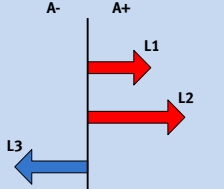
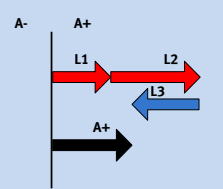
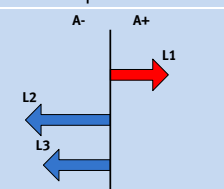
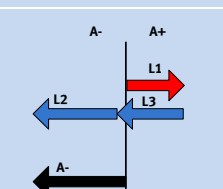
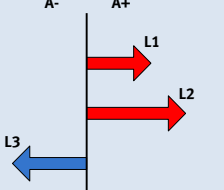
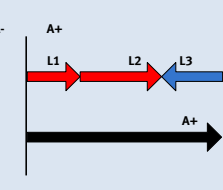
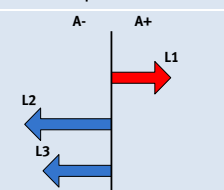
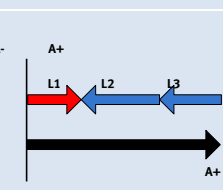
In Table 3, the instantaneous values for different power registers in OMNIPOWER are listed. Some of these values are also available as mean values. The values are either averaged during the corresponding integration time for the load profile or during the configurable log interval for the analysis logger.

Designation	Description	Unit	Display OBIS codes
P+mean	Mean value of the positive active power during the legal integration period.	kW	1.25.0
P-mean	Mean value of the negative active power during the legal integration period.	kW	2.25.0
Q+mean	Mean value of the positive reactive power during the legal integration period.	kvar	3.25.0
Q-mean	Mean value of the negative reactive power during the legal integration period.	kvar	4.25.0
S+mean	Mean value of the positive apparent power during the legal integration period.	kVA	9.25.0
S-mean	Mean value of the negative apparent power during the legal integration period.	kVA	10.25.0

Table 8: Mean power values in OMNIPOWER.

The above mean values are also available for each phase L1-3, see Analysis logger p.33.

4.4.5 Peak power values

The meter also registers the peak value for the power measurements. The measuring period of the peak calculation follows the load profile integration period. For every integration period, the mean power is calculated and then compared to the present peak value. If the new value exceeds the present value, it replaces the present value.

Designation	Description	Unit	Display OBIS codes
P+max	Active positive power consists of active power from quadrants 1 and 4.	kW	1.6.0 1.6.x (tariff)
P-max	Active negative power consists of active power from quadrants 2 and 3 (incl. Tariff 1 & 2).	kW	2.6.0 2.6.1 2.6.2
Q+max	Reactive positive power consists of positive inductive power from quadrant 1 and positive capacitive power from quadrant 2.	kvar	3.6.0 3.6.x (tariff)
Q-max	Reactive negative power consists of negative inductive power from quadrant 3 and negative capacitive power from quadrant 4 (incl. Tariff 1 & 2).	kvar	4.6.0 4.6.1 4.6.2
S+max	Positive apparent powery from quadrants 1 and 4.	kVA	9.6.0 9.6.x (tariff)
S-max	Negative apparent power from quadrants 2 and 3.	kVA	10.6.0

Table 9: Peak power values in OMNIPOWER.

The peak power values are reset at every debiting stop executed in the meter. See “Monthly debiting logger”, p. 32 for further information about debiting stop and the debiting logger.

4.4.6 Energy tariff registers

OMNIPOWER contains for each main energy registers; A+, A-, R+, R-, E+ and E-, up to 8 deviated tariff registers. The use of tariff registers enables the possibility for time-segmentation of the total energy consumption, relevant when electricity is prize differentiated according to the time of use during a day, week or season. Which tariff that is to be active, can be controlled in three different ways:

- by hardware using a 230 VAC input signal
- by an on demand remote command sent from a smart metering system
- by an internal tariff plan configuration in the meter

These options are described in the following sections.

4.4.6.1 Hardware-controlled – 230 VAC input

A list of available Kamstrup modules for OMNIPOWER includes a 230 VAC input that provides a 2- or 4-tariff control option. The modules are:

- Tariff stand alone (4-tariff)
- M-Bus module (2-tariff)
- RS485 module (2-tariff)

Module I/O-controlled tariffs use the ports of the module connector for changing the tariffs, e.g. if a tariff control module prepared for 230 VAC is connected to 230 VAC. The inverted function can also be selected. The control table is shown in Table 10.

Port 1: Terminals 13 and 15	Port 2: Terminals 33 and 15	Active tariff	Active tariff inverted
0 VAC	0 VAC	T1	T4
230VAC	0 VAC	T2	T3
0 VAC	230VAC	T3	T2
230VAC	230VAC	T4	T1

Table 10: Tariff control table.

Whether or not the active tariff is inverted, it is configured as part of the meter order form (SW-software configuration parameter Z3).

4.4.6.2 On demand – system-controlled

With OMNIPOWER connected to a smart metering system, the actual tariff can be set by a single remote command.

4.4.6.3 Internal tariff plan in the meter

An OMNIPOWER meter can contain up to three different tariff plans which can be selected on-site via the user interface (i.e. the sealable push-button) or remotely e.g. via OMNIA Suite.

OMNIPOWER direct and CT meters

Each tariff plan can have one, two, three or four different season plans available. In one year, the meter can shift up to 8 times between the available season plans. Each season plan consists of one, two or three types of days:

- Working days,
- Non-working days,
- Holidays.

A daily tariff plan can finally be made individually for each of the three different types of days. The tariff plan setup is illustrated in Figure 14.

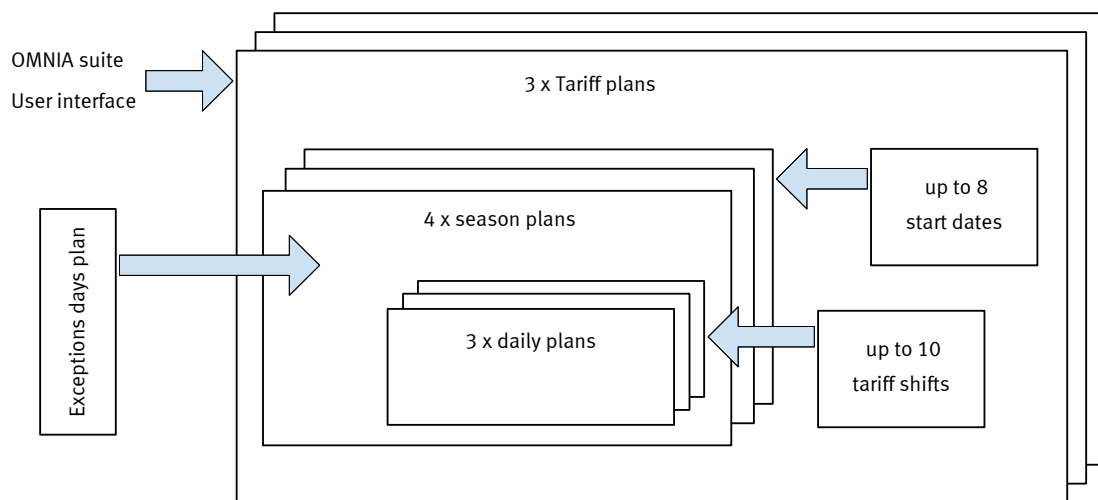

Figure 14: Tariff plan setup for OMNIPOWER.

A daily tariff plan in the meter can contain up to 10 tariff shifts per day and the resolution of the shifting is 1 minute.

4.5 Data loggers

OMNIPOWER has a number of different data loggers:

- Load profile logger (15 minutes, half-hourly or hourly energy logger)
- Monthly debiting logger
- daily, weekly or monthly debiting logger
- Analysis logger.

The loggers are different regarding the number of registers to be logged, the time interval between logs and the configuration possibilities. Each logger is described in the following.

Notice!! All time stamps in data loggers are done in normal time and **does not** take eventually daylight light saving time into account.

4.5.1 Load profile (1.1.99.1.0.255)

The load profile logger is based on energy readings where the types of energy to be logged are based on the meter configuration selected when ordering the meter. The load profile in OMNIPOWER is implemented according to WELMEC software guide 11.2.

The integration period of the meter is changeable and can be set to 15, 30 or 60 minutes. The period can be reconfigured after installation.

Depending on the chosen integration period and the number of energy types to be measured, OMNIPOWER contains a number of log entries which are converted to a number of days and listed in Table 11.

For OMNIPOWER CT meters the meter can be ordered to register either secondary or primary values in the load profile logger. This cannot be reconfigured afterwards.

Integration period \ Energy type	15 min. [Days]	30 min. [Days]	60 min. [Days]
A+	275	550	1100
A+/A-	231	462	924
A+/R+	231	462	924
A+/R1	231	462	924
A+/A-/R+/R-	175 ⁵	350	700

Table 11: Logging depth of load profile logger.

Each log entry is also marked with a status marking, which is also implemented according to WELMEC 11.2. It contains information regarding the quality of each specific log entry, e.g. any voltage outage, over voltages and under voltages and any eventually RTC adjustments executed during the integration period.

⁵ Variant 2 meters has extended logging depth of 180 days of 15 min values.

OMNIPOWER direct and CT meters

4.5.2 Monthly debiting logger (1.1.98.1.0.255)

OMNIPOWER has a debiting logger where the instantaneous values of a number of predefined registers are logged every time a debiting stop is executed. The predefined registers that are part of the debiting logger are listed in Table 12.

Various	OBIS codes	Energy registers	OBIS codes	Power registers	OBIS codes
RTC w/Quality	0.1.1.0.0.255	Active energy A+	1.1.1.8.0.255	P+max	1.1.1.6.0.255
		Active energy A-	1.1.2.8.0.255	P+max RTC	1.1.1.6.0.255
Hour counter	0.1.96.8.0.255	Reactive energy R+	1.1.3.8.0.255	Accumulated P+max	1.1.1.2.0.255
Number of debiting periods	1.1.0.1.0.255	Reactive energy R-	1.1.4.8.0.255	Accumulated P+max Tariff 1	1.1.1.2.1.255
Power threshold counter	1.1.96.51.2.255	A+ Tariff 1 - 4	1.1.1.8.x.255	Accumulated P+max Tariff 2	1.1.1.2.2.255
Pulse input	1.1.0.128.1.255	R+ Tariff 1 – 4	1.1.3.8.x.255	Q+max	1.1.3.6.0.255
Current transformer ratio ⁶	1.1.0.4.2.255	Apparent energy E+	1.1.9.8.0.255	Q+max RTC	1.1.3.6.0.255
		Apparent energy E-	1.1.10.8.0.255	Accumulated Q+max	1.1.3.2.0.255
				P+max Tariff 1	1.1.1.6.1.255
				P+max Tariff 1 RTC	1.1.1.6.1.255
				P+max Tariff 2	1.1.1.6.2.255
				P+max Tariff 2 RTC	1.1.1.6.2.255
				Q+max Tariff 1	1.1.3.6.1.255
				Q+max Tariff 1 RTC	1.1.3.6.1.255
				Q+max Tariff 2	1.1.3.6.2.255
				Q+max Tariff 2 RTC	1.1.3.6.2.255
				S+max	1.1.9.6.0.255
				S+max RTC	1.1.9.6.0.255
				S-max	1.1.10.6.0.255
				S-max RTC	1.1.10.6.0.255

Table 12: Registers stored in debiting logger.

The interval between each debiting stop/debiting log can be controlled by the meter and can be set to make an automatic log of the registers every month, every second month, every third month, every half year or once a year. The debiting stop can also be done on request, either by a command from an MDM system like OMNISOFTE VisionAir or manually by using the sealable push-button if the meter is configured accordingly. The maximum number of log entries in the meter is 36. When this number of logs has been reached, the meter overwrites the oldest entries.

⁶ Register in OMNIPOWER CT meter only.

4.5.3 Daily/weekly/monthly debiting logger (1.1.98.2.0.255)

In the same way, OMNIPower also contains a daily or weekly based debiting logger. The registers that are logged are listed in table 13.

Various	OBIS codes	Energy registers	OBIS codes
RTC w/Quality info	0.1.1.0.0.255	Active energy A+	1.1.1.8.0.255
		Active energy A-	1.1.2.8.0.255
Hour counter	0.1.96.8.0.255	Reactive energy R+	1.1.3.8.0.255
		Reactive energy R-	1.1.4.8.0.255
		Active energy A+ Tariff 1 - 4	1.1.1.8.x.255
		Active energy A- Tariff 1 - 4	1.1.2.8.x.255
		Reactive energy R+ Tariff 1 - 4	1.1.3.8.x.255
		Reactive energy R- Tariff 1 - 4	1.1.4.8.x.255

Table 13: Registers stored in debiting logger 2.

The interval between each debiting stop is controlled by the meter and must be set to either daily or weekly logging. There are no possibilities for executing a debiting stop on request for this logger. The maximum number of entries in the logger is 175.

4.5.4 Analysis logger (1.1.99.1.1.255)

The analysis logger allows you to configure the registers to be logged and the log interval:

- Up to 16 different registers
- Changeable log intervals: 5, 15, 30 or 60 minutes – independent of load profile settings.

Registers	OBIS Codes	Registers	OBIS Codes	Registers	OBIS Codes
Pulse input	1.1.0.128.1.255	P _{L1} ,	1.1.21.25.0.255	I _{L1} ,	1.1.31.25.0.255
Hour counter	0.1.96.8.0.255	P _{L2} ,	1.1.41.25.0.255	I _{L2} ,	1.1.51.25.0.255
Active energy A+	1.1.1.8.0.255	P _{L3} ,	1.1.61.25.0.255	I _{L3}	1.1.71.25.0.255
Active energy A-	1.1.2.8.0.255	P _{-L1} ,	1.1.22.25.0.255	U _{L1} ,	1.1.32.25.0.255
Reactive energy R+	1.1.3.8.0.255	P _{-L2} ,	1.1.42.25.0.255	U _{L2} ,	1.1.52.25.0.255
Reactive energy R-	1.1.4.8.0.255	P _{-L3}	1.1.62.25.0.255	U _{L3}	1.1.72.25.0.255
Reactive energy R1	1.1.5.8.0.255	Q _{+L1} ,	1.1.23.25.0.255	PF _{L1} ,	1.1.33.25.0.255
Reactive energy R2	1.1.6.8.0.255	Q _{+L2} ,	1.1.43.25.0.255	PF _{L2} ,	1.1.53.25.0.255
Reactive energy R3	1.1.7.8.0.255	Q _{+L3}	1.1.63.25.0.255	PF _{L3}	1.1.73.25.0.255
Reactive energy R4	1.1.8.8.0.255	Q _{-L1} ,	1.1.24.25.0.255	THDU _{L1} ,	1.1.32.24.124.255
A+ Tariff 1-8	1.1.1.8.x.255	Q _{-L2} ,	1.1.44.25.0.255	THDU _{L2} ,	1.1.52.24.124.255
A- Tariff 1-8	1.1.2.8.x.255	Q _{-L3}	1.1.64.25.0.255	THDU _{L3}	1.1.72.24.124.255
R+ Tariff 1 -8	1.1.3.8.x.255	S _{+L1} ,	1.1.29.25.0.255	THDI ⁷ _{L1} ,	1.1.31.24.124.255
R- Tariff 1-8	1.1.4.8.x.255	S _{+L2} ,	1.1.49.25.0.255	THDI ⁷ _{L2} ,	1.1.51.24.124.255
Active energy A1423	1.1.15.8.0.255	S _{+L3}	1.1.69.25.0.255	THDI ⁷ _{L3}	1.1.71.24.124.255
Active energy A+Net	1.1.16.8.0.255	S _{-L1} ,	1.1.30.25.0.255	Frequency	1.1.14.25.0.255
Apparent energy E+	1.1.9.8.0.255	S _{-L2} ,	1.1.50.25.0.255		
Apparent energy E-	1.1.10.8.0.255	S _{-L3}	1.1.70.25.0.255		
Actual power P+	1.1.1.7.0.255	Cut-off state	1.1.128.0.0.255		
Actual power P-	1.1.2.7.0.255	P+ max, daily	1.1.1.16.0.255		
Actual power Q+	1.1.3.7.0.255	P+ min., daily	1.1.1.13.0.255		
Actual power Q-	1.1.4.7.0.255	P+ max, daily – RTC	1.1.1.16.0.255		
Power Factor Avg	1.1.13.25.0.255	P- min.,daily – RTC	1.1.1.13.0.255		

Table 14: Registers available for analysis logger.

⁷ Not in OMNIPower CT meters

The logging depth of the analysis logger depends on the log interval and the number of registers in the analysis logger. The meter is preconfigured from factory regarding the registers to be logged and the interval by which they are logged, but these settings can be reconfigured. The log interval is default set to 15 min. An example of the default setup of the analysis logger can be seen in Table 15.

Meter type	OMNIPOWER single-phase				OMNIPOWER three-phase			
Registers in the load profile logger	1 register	2 registers		4 registers	1 register	2 registers		4 registers
Default registers in the analysis logger	A+	A+/A	A+/R+	A+/A-/R+/R-	A+	A+/A	A+/R+	A+/A-/R+/R-
Actual power P+	x	x	x	x	x	x	x	x
Actual power P-		x		x		x		x
Actual power Q+			x	x			x	x
Actual power Q-				x				x
Average voltage L1	x	x	x	x	x	x	x	x
Average voltage L2					x	x	x	x
Average voltage L3					x	x	x	x
Average current L1	x	x	x	x	x	x	x	x
Average current L2					x	x	x	x
Average current L3					x	x	x	x
Logging depth of analysis logger [Days]	--	--	--	--	--	--	--	--

Table 15: Default setup for analysis logger.

Mean phase voltage and mean phase current are calculated as the mean value during the log interval period configured for the analysis logger.

Phase currents are shown as absolute values without indicating the direction of the current.

4.6 Meter readout

The OMNIPOWER meters offer a range of options regarding meter data readout. It spans from simple display reading to advanced remote readout for smart metering systems.

4.6.1 Manual display readout

The display can show all relevant meter data, e.g. power and energy, phase currents and voltages, meter number etc. etc. Even the load profile and the debiting logger can be read out in the display. The complete design of available segments in the display is shown in Figure 15.

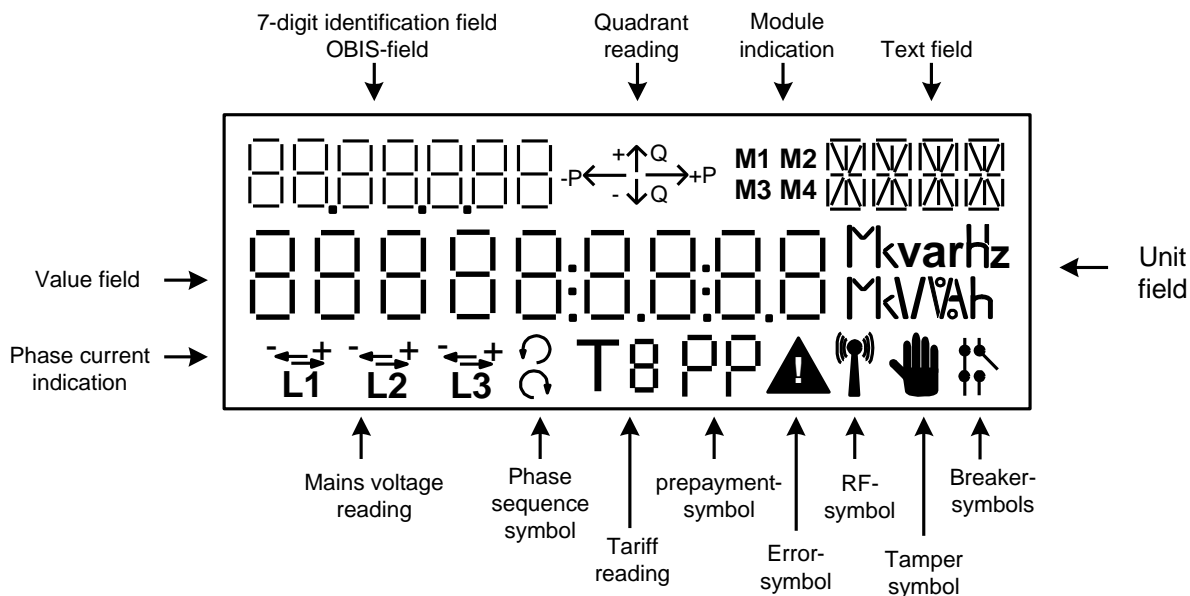

Figure 15: OMNIPOWER display.

In the following sections, the different display segments are described.

4.6.2 9-digit value field

This field is used for displaying all kind of register values. Meter energy is stated in [6.1], [6.3] [7.0] or [7.2] format with either “kWh” or “kvar” as unit. Power is shown with [2.3] format (00.000) and either “kW” or “kvar” as unit. Date/time can also be shown in the display and is stated according to the formats YYYY:MM:DD and HH:MM:SS respectively. In both cases without any units shown.

Register values like meter number, special data, etc. are indicated by 8 digits also without any unit. The value field can be configured to display leading zeroes of all energy readings.

What to be shown in the value fields depends on the configuration of the display. The configuration of the display is explained further in section 5.4. The display showing can also be remotely updated after installation of the meter with the OMNISOFT VisionAir MDM system.

4.6.2.1 Unit field

The unit field is used for displaying the units of registers in the value field.

OMNIPOWER direct and CT meters

4.6.2.2 Object identification field

Field for identifying the value in the value field. OBIS codes are used in connection with the identification.

4.6.2.3 Quadrant reading

The total current load is indicated by the arrows for +P (imported active power), -P (exported active power), +Q (inductive reactive power) and -Q (capacitive reactive power), respectively.

The quadrant reading is an instantaneous total value for all three phases. The reading is not active when the load is below the minimum limit of 10 mA RMS.

It is configurable whether the quadrant indication shall be visible in the display.

4.6.2.4 Text field

The text field is used either for additional information about the unit field regarding values in the value field or for text information. In the latter case, text messages are shown as scrolling text in the field.

4.6.2.5 Module indication

Indicates whether a module is communicating with the meter, and in this case which module, e.g. internal radio, primary module or CCC-module (However, this feature is not yet activated).

4.6.2.6 Error symbol

Only used internally by Kamstrup.

4.6.2.7 Breaker symbol⁸

If the meter is configured with an internal breaker, the position of the breaker is indicated as either connected or disconnected. However, if the smart disconnect functionality is disabled, both symbols are off.

4.6.2.8 Tamper symbol

Indicates either a magnetic field near the meter or if the meter cover has been removed from the meter.

4.6.2.9 Radio network symbol

If a meter is to be used in an OMNICON Radio Mesh Network, the symbol indicates the meter's connection status with the network.

4.6.2.10 Prepayment symbol⁸

The symbol indicates whether the prepayment functionality is activated.

4.6.2.11 Tariff indication

The tariff indicator can show T1, T2, T3, T4, T5, T6, T7 and T8 to indicate the currently active tariff. The tariff reading is updated every 10 sec., i.e. it may take up to 10 seconds from a tariff shift has been carried out until the current tariff is displayed.

The tariff indication is switched off if display configuration without tariff reading has been selected.

⁸ Not available for OMNIPOWER CT meters

4.6.2.12 Mains voltage reading

The mains voltage readings per phase L1, L2 and L3 indicate whether voltage is applied to the individual phase input terminal or not.

Indications L1, L2, L3	Indicate
On	The voltage is above minimum limit (160VAC).
Off	The voltage is below minimum limit (160VAC).

Table 16: Main phase voltage indication.

The minimum voltage limit is 160 VAC ±5 %. If the voltage remains below minimum limit for more than 1 second in all phases, the processor shuts down and the meter is reset.

4.6.2.13 Phase current indication

The direction of the current for each phase is shown with these indicators. It can be useful when checking if inputs and outputs have been installed correctly.

Indications 	Indicate
On	The load is above minimum limit.
Off	The load is below minimum limit.

Table 17: Phase current indication.

The minimum load limit for phase current indication is approx. 2.3 W (0.6W for OMNIPower CT meters). If the phase current is lower than this value, energy registration stops, and the phase current indication turns off in the display.

4.6.2.14 Phase sequence indication

This shows the phase sequence of the input phases. If both symbols are off, this indicates that no sequence could be clearly recognized. The reason could be that one or two phases are missing on the input.

4.6.3 Protocols

A number of communication protocols are available with OMNIPower.

- Kamstrup Meter Protocol
- DLSP/COSEM
- EN 62056-21 (1107) Mode A & C

4.6.3.1 Kamstrup Meter Protocol (KMP)

KMP is a communication protocol that is suited for communication with OMNIPower. It gives access to all registers in the meter and enables programming and setup. Please contact Kamstrup A/S for further information about this protocol.

The communication module can be delivered pre-mounted in the meter, or it can be mounted after the meter is installed. The post-mounting of the modules can be done without removing the power to the meter terminal connection.

4.6.7 Full encryption on all interfaces

OMNIPOWER meters with SW no. 55981173 or 50981165 introduce full data encryption on all communication interfaces including the primary module port, CCC module port and the optical interface. The encryption method used is AES 128-bit and it covers read out of all consumption/production data, read and write possibilities of configuration parameters and control commands like disconnect/reconnect of the internal breaker.

Kamstrup OMNIA Suite supports full read out, configuration and control of encrypted OMNIPOWER meters. For 3rd party MDM systems to be able to support encrypted meters, it is required that the systems connect to Kamstrups KMS (Key Management Service), which will allow the MDM to access all unique encryption keys for the relevant meters.

For more information about encrypted meters and KMS, please contact Kamstrup A/S.

4.6.8 M-Bus and RS-485 connectivity

Meters can be delivered with M-Bus or RS-485 connectivity modules. The M-Bus module communicates through the EN13757-2/3 protocol. The RS-485 module can be used with the KMP, DLMS and 1107 protocols.

4.7 Modularity options

OMNIPOWER meters have two independent module areas available for communication. Both module areas are per default available on all OMNIPOWER meter types.

4.7.1 Primary modules

The primary module area can be used for communication modules as described in the previous section, but it can also be used for tariff control modules, load control modules, etc.

4.7.2 CCC modules

The second module area, which is shown in Figure 17, offers access to the Consumer Communication Channel (CCC).



Figure 17: CCC-module area in OMNIPOWER.

OMNIPOWER direct and CT meters

CCC-modules are intended for in-home communication as shown in Figure 18. The communication can be one way to e.g. an in-home display, or it can be two-way for intelligent control of e.g. relays in the home. CCC-modules also enable the utilities to send consumer-related information, e.g. price signals to in-home displays directly from their MDM or other business systems.

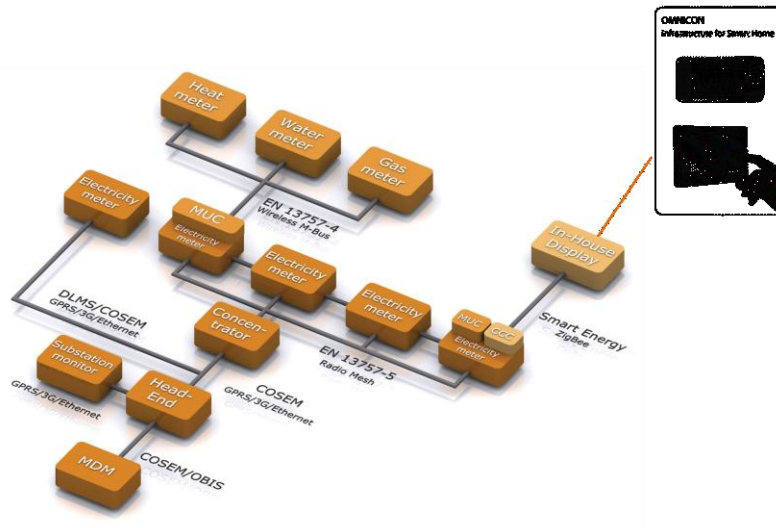

Figure 18: CCC-module in OMNIA Suite.

A suitable technology for in-home communication is ZigBee® Smart Energy or similar.

4.8 Disconnect functionality (1.1.128.0.11.255)

The following description applies to OMNIPOWER direct meters with integrated breakers. Meters with integrated breakers can disconnect and reconnect the consumer’s supply. All meters with integrated breaker are marked on the front of the meter as shown in the figure.

The breaker is controlled by the meter’s main processor and is bistable, i.e. it maintains its status, i.e. connected/disconnected, independently of the main supply status of the meter.

The integrated breaker disconnects all the output phases in the meter while the neutral connection is not disconnected.

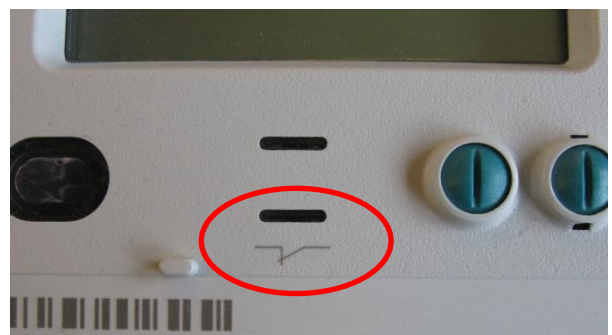

Note!! The breaker must **not** be used for safety cut-off.

For both OMNIPOWER three-phase and OMNIPOWER single-phase meters, the integrated breakers are approved according to EN 62055-31, Annex C for UC3 breaking capabilities. This means that the meter fulfills following:

- 10.000 makes-and-breaks cycles @ 100A (5.000 @ PF=1.0 and 5.000 @ PF=0.5 inductive)
- Shortcircuit current carrying capacity 6kA/3kA (Test1/Test2)

The UC3 approval documents can be handed out by Kamstrup on request.

4.8.1 Disconnect function in the meter

The meter can be delivered with integrated breakers. It is possible to disconnect the breaker in four ways:

- Manually by activating the left push-button
- Remotely from a smart metering system
- By smart disconnect – intelligent disconnection when voltage, current or power exceeds a preconfigured limit
- By the integrated prepayment option.

When the breaker is disconnected, it is possible to reconnect the breaker in four ways:

- Manually by activating the left push-button
- Remotely via a release command and an additional reconnect command
- With a combination of a release command sent from a smart metering system and a manual reconnect on the push-button.
- Automatically after current and power level are back to normal or credit (if prepayment is activated) is restored.

Independently of the way of reconnect, the reconnection time is minimum 5 seconds. It is configurable which of these options are available in a meter. In the following sections, the different control options are described in details.

4.8.2 Manual disconnection and reconnection

It is possible to disconnect the breakers manually. This is done in the following way:

1. On the meter, select the shown display reading by activating the left push-button.
2. Activate the left push-button for approx. 6 seconds. This disconnects the relays, and the red LED turns on.

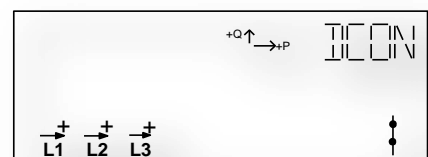

Manual reconnection is done in the following way:

3. On the meter, select the primary display reading when the red LED is flashing.
4. Activate the left push-button for 6 seconds until the relays are connected and the red LED turns off.

OMNIPOWER direct and CT meters

4.8.3 Remote disconnection from a smart metering system

OMNIPOWER meters with integrated breakers can also have their breakers disconnected, released and reconnected remotely. As a safety precaution, the remote disconnect functionality in OMNIA Suite is encrypted by encrypted communication.

4.8.4 Smart disconnect

The meter includes a smart disconnect feature that disconnects the breakers if either the total current or power exceeds a preconfigured limit.

4.8.5 Disconnection basis

The choice of “disconnection basis” setup decides if smart disconnect is enabled or disabled, and on which basis the smart disconnect is effected if enabled. It is possible to select:

- **No function:** The smart disconnect function is disabled.
- **Current-controlled:** Smart disconnect is effected when a configured current limit is exceeded.
- **Power-controlled:** Smart disconnect is effected when a configured power limit is exceeded.
- **Voltage controlled:** Smart disconnect is effected when a configured phase voltage limit is exceeded.
- **Prepayment:** The prepayment function controls the disconnection.

The disconnection basis is selected as part of the smart disconnect configuration. Per default, the meter is provided with the smart disconnect functionality disabled. If the function is to be used, it can be enabled from the factory at delivery, it can be activated remotely or locally with METERTOOL OMNIPOWER.

4.8.6 Current-controlled disconnection

Current-controlled disconnection is based on RMS current with average calculation every 1 second. Disconnection is effected if one of the phase currents I_{L1} , I_{L2} or I_{L3} exceeds the limit $I_d \cdot k_x$ for a configured time period; t_1 , t_1+t_2 or $t_1+t_2+t_3$.

4.8.7 Power-controlled disconnection

Power-controlled disconnection is based on the total power in all phases. Disconnection is effected if the total phase power exceeds the limit $I_d \cdot k_x$ for a configured time period; t_1 , t_1+t_2 or $t_1+t_2+t_3$.

At smart disconnect configuration, the disconnect current $I_{disconnect}$ (I_d) or the disconnect power $P_{disconnect}$ (P_d) is set, and it must be determined whether the smart disconnect is to be based on either current or power. The breaker then disconnects the supply when I_d or P_d is exceeded.

OBIS Code	Register	Min. value	Max value
1.1.128.0.13.255	$I_{disconnect}$	0 A	80 A
1.1.128.0.13.255	$P_{disconnect}$	0 kW	80 kW

Table 18: Configuration limits for smart disconnect.

4.8.8 Delayed disconnection

The meter can be configured to delay the disconnection and to differentiate the disconnection characteristics. This is done with configurable multiplication factors for both time : t_1 , t_2 , t_3 and current/power factors: k_1 , k_2 , k_3 .

OBIS Code	Register	Min. value	Max value
1.1.128.0.2.255	k_1 ,	0	9.9
1.1.128.0.3.255	k_2 ,		
1.1.128.0.4.255	k_3		
1.1.128.0.5.255	t_1 ,	0	65535
1.1.128.0.6.255	t_2 ,		
1.1.128.0.7.255	t_3 [sec.]		

Table 19: Multiplication factors for smart disconnect.

The following conditions for the factors must be met at configuration:

$$t_1 \leq t_2 \leq t_3 \text{ and } k_3 \leq k_2 \leq k_1$$

The meter disconnects the supply if one of the below conditions is met for current or power, respectively.

Current			Power		
$I > I_d * k_3$	and	$t > t_1 + t_2 + t_3$	$P > P_d * k_3$	and	$t > t_1 + t_2 + t_3$
$I > I_d * k_2$	and	$t > t_1 + t_2$	$P > P_d * k_2$	and	$t > t_1 + t_2$
$I > I_d * k_1$	and	$t > t_1$	$P > P_d * k_1$	and	$t > t_1$

Table 20: Disconnect conditions for OMNIPOWER.

The condition in Table 20 is also illustrated in Figure 19.

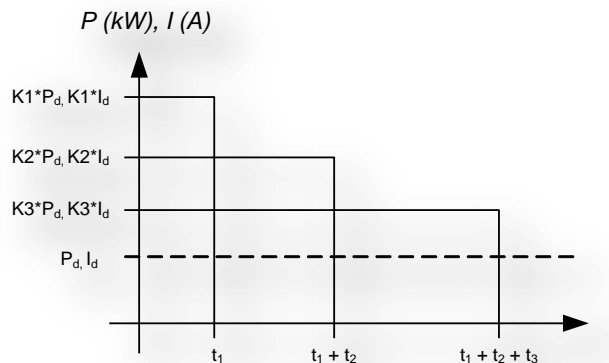

Figure 19: Differentiation of smart disconnection.

4.8.9 Reconnection

Reconnection can be configured to be either manual or automatic. In OMNIPOWER meters that are part of a smart metering system, the meters can be configured to allow manual reconnection – provided that the meter is first released for manual reconnection by the utility. The meter is released by sending a remote command to the meter.

4.8.10 Overvoltage disconnection

In addition to the smart disconnect functionality, OMNIPOWER meters also offers an option for automatic disconnect in case of an overvoltage on one or more phases. The overvoltage disconnect and reconnect are based on average values of the phase voltages and the activations can therefore be delayed by configuration of the

OMNIPOWER direct and CT meters

sample time parameters called “Sample-time disconnect” and “Sample-time reconnect”. Also the voltage thresholds for disconnect and reconnect are configurable.

In the example showed in figure 20 the four configuration parameters are set to following values.

- Over voltage disconnect level: 270V
- Over voltage reconnect level: 260V
- Over voltage sample-time for disconnect: 2 sec.
- Over voltage sample-time for reconnect: 5 sec.

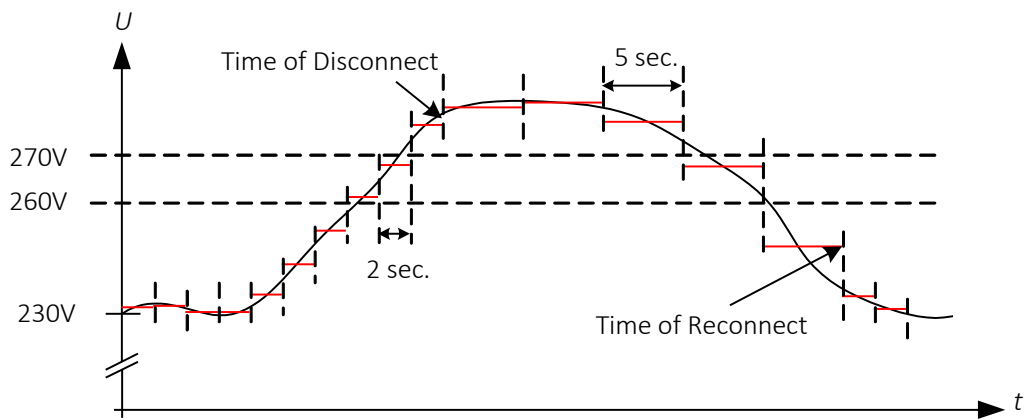

Figure 20: Example of over voltage disconnect and reconnect.

The configurations parameters have the range and resolution as given in tTable 21.

OBIS Code	Parameter	Value range (resolution)	Default value
1.1.128.0.19.255	Over voltage disconnect threshold	260-320V (1 V)	285V
1.1.128.0.20.255	Over voltage sample time for disconnect	1 – 3600 sec (1 sec)	1 sec
1.1.128.0.21.255	Overvoltage reconnect threshold	250-270V (1 V)	265V
1.1.128.0.22.255	Over voltage sampletime for reconnect	1 – 3600 sec (1 sec)	60 sec

Table 21: Overvoltage disconnect configuration parameters .

The overvoltage disconnect functionality is per default deactivated and can be activated using an AMR system or using METERTOL OMNIPOWER.

4.8.11 Disconnection on meters with APS

On an OMNIPOWER meter with auxiliary power supply (APS), the disconnection functionality differs from the description in the previous chapters.

If an OMNIPOWER meter with APS is supplied by main terminals L1, L2 and L3, the functionality is the same as mentioned earlier, but when this meter is supplied from the APS input, no breaker activation is possible, neither disconnection nor reconnection.

4.8.12 Event logger for disconnect/connect history (1.1.99.98.5.255)

A meter with breaker includes a logger that registers all events that are related to the disconnect functionality. For each event, that be a disconnection, a release or a reconnection, the meter logs an ID, a timestamp, the disconnect state and the connection feedback.

The size of this logger is 200 logs.

4.8.13 Prepayment

The prepayment functionality is to be used with a smart metering system. Prepayment is only possible for meters with internal breaker and will not work together with tariffs. The prepayment function is per default disabled, but can be activated and deactivated as required.

4.8.14 Prepayment principle

Prepayment is based on the specific prepayment register $A_{14\text{prepayment}}$. When enabling the prepayment functionality, $A_{14\text{prepayment}}$ must be “loaded” with a number of kWh. This can only be done by using a system that supports the functionality.

As soon as the register contains a number of kWh and the functionality is enabled in the meter, the register starts counting down as the energy is consumed.

When $A_{14\text{prepayment}}$ has reached 0 kWh, the supply is disconnected, and a new value for the register must be programmed.

When prepayment is activated, the prepayment register $A_{14\text{prepayment}}$ must be activated in the display settings by activating a display setup that includes the prepayment register. If a display setup with the prepayment register is activated, the register is however only shown when prepayment is enabled.

When prepayment is activated in the meter, the “PP” symbol is indicated in the display as shown in figure.



Figure 21: The “PP” symbol shown in the meter display.

The unit in the display is “kWh”, and “PAY” is shown in the text field.

The prepayment is based on total energy consumption and do not support tariffs. Therefore, the functionality is disregarded if the meter is configured for tariffs.

$A_{14\text{prepayment}}$ can be configured to disconnect only on working days, i.e. not on non-working days, holidays or exception days. It is also possible to set a time slot, e.g. from 10:00 PM to 8:00 AM the following day where disconnection will not happen.

If $A_{14\text{prepayment}}$ reaches zero within one of the above mentioned exceptions, the disconnection happens on the next working day. In the meantime, the credit register $A_{14\text{prepayment,credit}}$ starts registering the energy that is consumed until disconnection takes place. When adding new kWh to the meter, the meter takes any consumption in the

OMNIPOWER direct and CT meters

credit register into account. The meter subtracts the value in $A_{14\text{prepayment,credit}}$ from the added amount of kWh and put the remaining kWh in $A_{14\text{prepayment}}$.

If $A_{14\text{prepayment}}$ has reached 0 kWh, and the breakers are disconnected, it is possible to reconnect under certain conditions. First, the load must be decreased below a defined limit called $I_{\text{exception}}$ or $P_{\text{exception}}$. The limits are configurable within the range given in Table 22.

After the load is limited, it is possible to reconnect the meter and by that still be able to use a minimum of power. Be sure to keep the consumption below the limit, or the meter will disconnect again. The duration in which the exception for current and power, respectively, can be active is however limited by a configurable number called $t_{\text{prepayment}}$. When the limit is exceeded, the consumer is disconnected until new kWh are added to the meter. In the intervening period, the consumed energy is also registered in $A_{14\text{prepayment,credit}}$.

OBIS Code	Register	Min. value	Max value
1.1.128.0.12.255	$I_{\text{exception}}$	0 A	80 A
1.1.128.0.12.255	$P_{\text{exception}}$	0 kW	80 kW
1.1.128.0.9.255	$t_{\text{prepayment}}$	0	255 days

Table 22: Configurable parameters for smart disconnect.

4.9 Power quality measurements

OMNIPOWER meters are equipped with a supply power quality measurement tool. It is based on the requirements in EN50160 regarding power quality delivered from utilities and includes the measurement of the following:

- Frequency variations
- Long-term and short-term over voltage and under voltage
- Power outages
- Rapid voltage change
- Supply voltage unbalance
- Total harmonic distortion (THD)
- Neutral fault detection
- Power factor.

In the following, these quality measurements are described. Power quality detection and registration in OMNIPOWER is based on events, i.e. information is only registered if an unexpected situation appears. Some events are registered with detailed information like time stamp and voltage level information, while other events are registered as a counting number in an occurrence counter.

4.9.1 Frequency measurements

Normally, frequency variations will not be relevant as most grids are synchronous connected to an interconnected grid-system, but in special cases where the grid is isolated, frequency measurements are relevant.

OMNIPOWER measures a 10-second mean value of the line frequency and compares this value with the boundaries given in EN50160. The total number of events where this 10-second mean value is outside the boundaries is registered in the occurrence counter in the meter.

It is also possible to include the line frequency in the analysis logger, where the meter will log an average value according to the log interval configured for the analyses logger.

4.9.2 Voltage variations

OMNIPOWER continuously (every second) updates the supply voltages at each phase and detects and registers any deviations from a set of user defined voltage limits, i.e. a deviation can be either an over voltage or an under voltage.

4.9.2.1 Long-term deviations

Long-term deviations are related to a mean value of the phase voltage. Therefore it is also called mean time deviation. The average time, $U_{\text{time-period,mean}}$ is configurable in the span from 10 seconds and up to 30 minutes. The mean value is calculated for every window and for each time the value is outside the boundaries, i.e. $>U_{\text{high,mean}}$ or $<U_{\text{low,mean}}$, the event is registered in the voltage quality logger. Figure 22 shows an example of a phase voltage that varies in time. In this period the average time is set to 10 seconds and the first and the third period is registered as deviations.

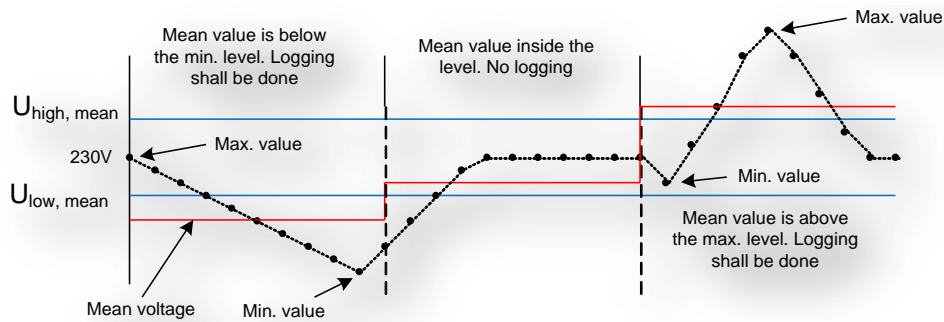

Figure 22: Example of long-term voltage deviation. Average time period is 10 second.

A long-term deviation is registered in the voltage quality logger in form of a time stamp (start time), a mean value, a maximum value and a minimum value for the period.

4.9.2.2 Short-term deviations

OMNIPOWER also detect and register deviations that last shorter than the average time for mean value deviations, described in section 4.9.2.1. This is described as short-term or single value deviation. Three examples of short-term voltage deviations are shown in Figure 23. In a case where the voltage is out of boundaries for several seconds the first value, the maximum/minimum value and the last value is registered. Every value is registered with a time stamp.

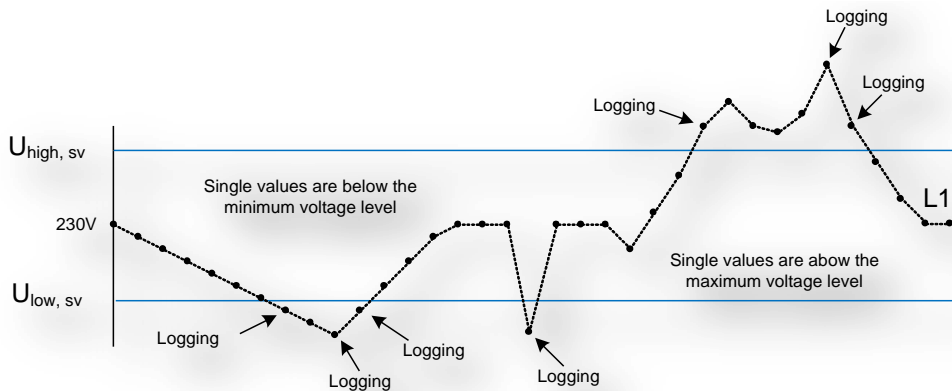

Figure 23: Example of short-term voltage deviations.

Deviations that last shorter than 1 second is registered as sags and swells, which is described in section 4.9.4.1.

4.9.3 Voltage outage

OMNIPOWER detects all voltage outages, whether they are happening on one, two or three phases and all events are registered in the voltage quality logger as two events; one for outage of the voltage and one for reestablishment of the voltage. The voltage detection level depends on the event. If the outage is on one or two phases (i.e. the meter is still powered by the third phase) the registration level is a configurable value between 50-160 V. If the power outage is all phases, the detection level is approximately 160 V. The detection levels are illustrated in Figure 24.

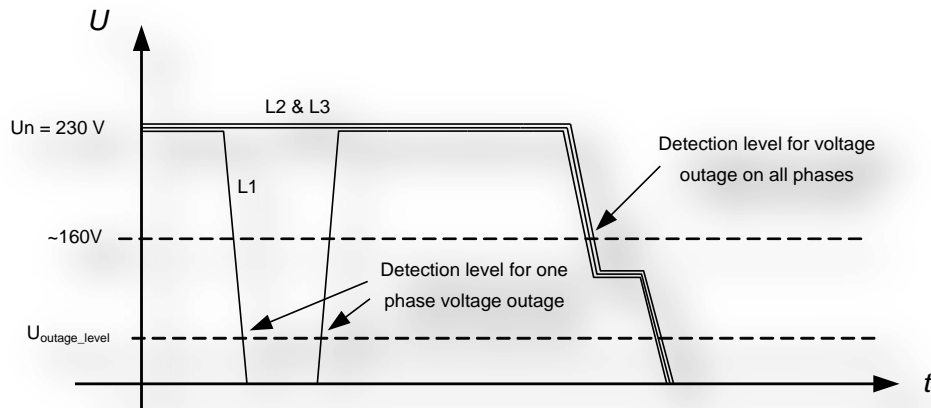

Figure 24: Detection levels for one phase and three phase voltage outage.

It is possible to configure the time the voltage outage shall be present before the event is logged. The value can be configured in the interval 0 second – 30 minutes.

All detected voltage outages are also registered in one of two occurrence counters that register the number of voltage outages. According to EN50160, voltage outages are divided into short voltage outages (≤ 3 minutes) and long voltage outages (> 3 minutes) and every voltage outage is registered in one of the two categories.

4.9.4 Configuration of power voltage measurements

The voltage quality measurements requires, as described in the previous sections, that a list of configurable parameters are set. The list is given in Table 23 and Figure 25 shows the visual function of the parameters.

Parameter	Description	Maximum value	Minimum value	Default value
$U_{high,mean}$	Voltage level for over voltage detection according to mean voltage deviation (in +% of nominal voltage).	276 V +20%	232.3 V +1%	253 V +10%
$U_{low,mean}$	Voltage level for under voltage detection according to mean voltage deviation (in % of nominal voltage).	227.7 V -1%	184 V - 20%	207 V -10%
$U_{time-period,mean}$	The time period for calculating the mean voltage.	10 sec.	30 min.	10 min.
$U_{low,sv}$	Voltage level for over voltage detection according to short-term deviation (in +% of nominal voltage).	276 V +20%	232.3 V +1%	253 V +10%
$U_{low,sv}$	Voltage level for under voltage detection according to short-term deviation (in -% of nominal voltage).	227.7 V -1%	184 V - 20%	207 V -10%
$U_{outagelevel}$	The voltage level for a voltage outage that happens on one or two phases (for three-phase meters)	160 V	50 V	50 V
$U_{outage,timethreshold}$	The time that a voltage outage has to be present before it is registered in the voltage quality logger.	0 sec.	30 min.	10 sec.

Table 23: Configurable parameters for voltage quality measurements.

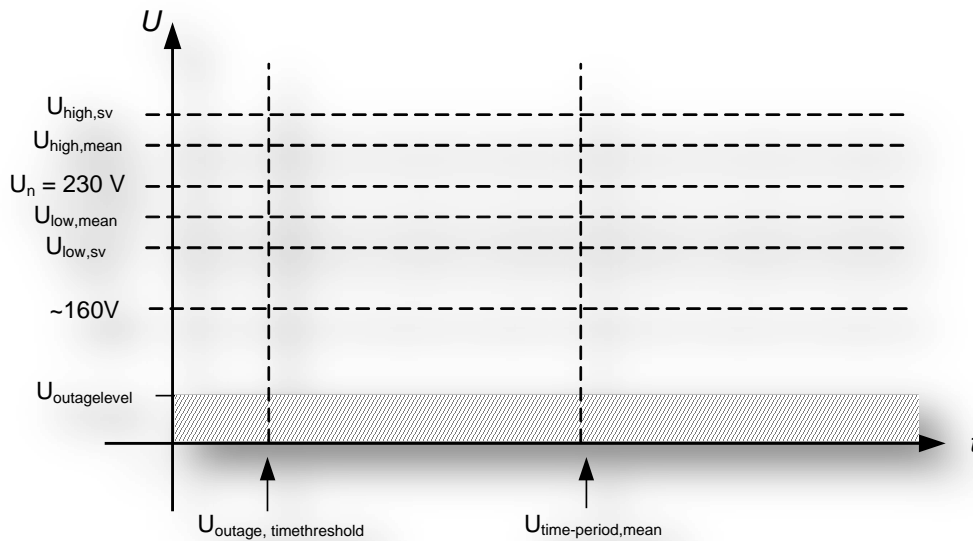

Figure 25: Configurable parameters for voltage quality measurements.

The parameters can be configured remote using an AMR system or locally using METERTOOL OMNIPOWER.

4.9.4.1 Voltage sags and swells with a duration 100 ms – 1 second.

OMNIPOWER also detects and registers the number of voltage sags (or dips) and voltage swells, which are events where phase voltage drops below 20% of U_n or rise above 20% of U_n for a period shorter than 1 minute. Sags and swells that last for more than 1 second are registered in the voltage quality logger as described in section 4.9.2.2. Sags and swells that last from 100 milliseconds to 1 second are detected and registered in one of two occurrence registers.

Voltage sags and swell are not registered with time stamp or any indication of voltage level. Instead the number of each event is registered in the meter. OMNIPOWER can only register 1 sag and swell per second.

4.9.5 Rapid voltage change

A rapid voltage change is defined as a change in the phase voltage within the boundaries set for over voltage and under voltage detection. For OMNIPOWER a rapid voltage change is defined as a change of %5 or more, between two subsequent samples of the phase voltage i.e. $\Delta V > 11.5\text{ V}$. Every rapid voltage change is registered in an occurrence counter register and this register is logged in the occurrence counter logger.

4.9.6 Supply voltage unbalance

Supply voltage unbalance is a number for the balance between the three phase voltage according to voltage level for each phase and the phase shift between the three voltages. EN50160 describes that the supply voltage unbalance must not exceed 2 % when calculated as a 10-minute mean value.

The OMNIPOWER meter continuously measures the supply voltage unbalance, and if the mean value exceeds the limit, the event is registered in an occurrence counter register and the register is logged in the occurrence counter logger.

4.9.7 Total harmonic distortion (THD)

The OMNIPOWER meters also measures the THD (current THDI⁹ and voltage THDU) for each phase. According to EN50160, a 10-minute mean value for THDU for each phase is calculated, and if one of these values exceeds 8 %, which is the maximum limit in EN50160, the event is registered in an occurrence counter register for the specific phase. The calculation of THD includes up to the 40th harmonics.

In total OMNIPOWER have 6 occurrences counter registers for THD, one for THDU and one for THDI for each phase. All six registers are logged in the occurrence counter logger.

Both THDU and THDI is also available in the analysis logger for continuously logging of the mean value according to the integration period for the analysis logger.

4.9.8 Readout of the power quality measurements

As described in the last sections, the OMNIPOWER meter continuously make a number of power quality measurements. The result of the measurements are registered in two loggers,

1. A voltage quality logger: Logs over voltage, under voltage and voltage outage events.
2. An occurrence counter logger: Logs the number of events of different power quality parameters.

In this section is given some examples on the information that the two loggers provide when they are read out from the meter.

4.9.8.1 Voltage quality logger (1.1.99.98.16.255)

To show what and how the information is registered in the power quality logger, some figures from earlier sections are reused. In Figure 26 is shown how the mean voltage is calculated in terms of a 10-second sample period. Normally the sample period will be higher, e.g. 1 minute or 10 minute.

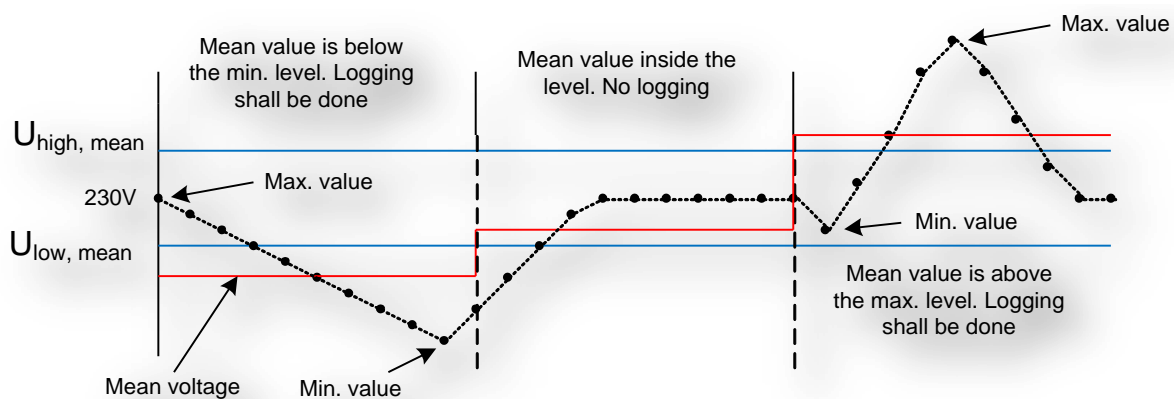

Figure 26: Example of long-term voltage deviations.

⁹ THDI is Not available in OMNIPOWER CT meters.

OMNIPOWER direct and CT meters

For the example in Figure 26 the corresponding information in the logger is given in Table 24. For every period the mean value is outside the boundaries, there is a log entry.

Log ID	Time	Phase	Event	Mean Value	Max Value	Min Value
1	13:50:10 (Start time)	1 (L1)	0 (Under voltage)	215	230	204
2	13:50:30 (Start time)	1 (L1)	1 (Over voltage)	244	260	220

Table 24: Examples of a registration of long time voltage deviations in the voltage quality logger.

Similar we can see at different short-term voltage deviations in Figure 27.

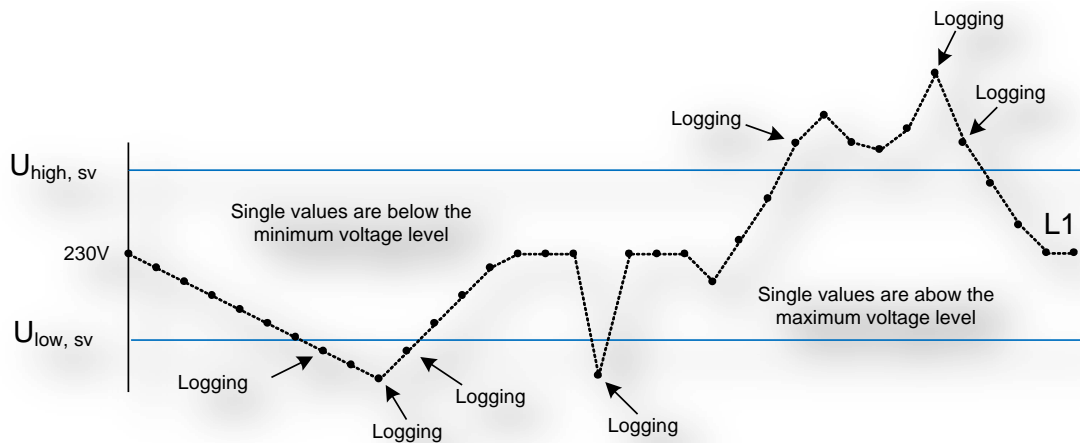

Figure 27: Example of short-term voltage deviations.

An example of the corresponding information in the read out is given in Table 25. For every period where several values are outside the boundaries, the first value, the minimum/maximum value and the last value is registered.

Log ID	Time	Phase	Event	Mean Value	Max Value	Min Value
3	14:32:17	1 (L1)	6 (Single value min Start)	0	0	210
4	14:32:19	1 (L1)	2 (Single value min Peak)	0	0	204
5	14:32:20	1 (L1)	7 (Single value min Stop)	0	0	208
6	14:32:27	1 (L1)	6 (Single value min Start)	0	0	204
7	14:32:34	1 (L1)	8 (Single value max Start)	0	253	0
8	14:32:39	1 (L1)	3 (Single value max Peak)	0	262	0
9	14:32:40	1 (L1)	9 (Single value max Stop)	0	252	0

Table 25: Examples of a registration of short time voltage deviations in the voltage quality logger.

4.9.8.2 Occurrence counter logger (1.1.99.98.17.255)

A large number of occurrence counter registers are described in the previous sections. In Table 26 they are all listed in an example of a read out of the occurrence counter logger with a log interval of one day. I.e. every midnight, the numbers in the occurrence counter registers are logged. With this information it is possible to calculate the total percentage of time that conditions has been out of the boundaries given in EN 50160. Table 26 shows these calculations to the right. In the example it can be seen that the THDU_L2 is above the requirements (THDI higher than 8% for more than 5 % of the time in a week).

Log ID (Daily)	1	2	3	4	5	6	7	No. of events in a week.	Total time in a week.
RTC (example with daily log interval)	22/01/2014	23/01/2014	24/01/2014	25/01/2014	26/01/2014	27/01/2014	28/01/2014		
VQ_Counter_F1 (50Hz – 2%)	0	0	0	0	0	0	0	0	0
VQ_Counter_F2 (50Hz + 2%)	0	0	0	0	0	0	0	0	0
VQ_Counter_VoltageVariation_Low1 (<10% of U _n for a 10 minute mean value)	2	3	5	2	9	6	4	31	3.1 %
VQ_Counter_VoltageVariation_Low2 (<15% of U _n for a 10 minute mean value)	0	0	0	0	1	0	1	2	0.2 %
VQ_Counter_VoltageVariation_High (>10% of U _n for a 10 minute mean value)	1	1	2	1	1	2	1	9	0.9 %
VQ_Counter_RapidVoltageChanges	3	4	4	5	1	2	2	21	
VQ_Counter_Voltage_Unbalance	1	1	2	7	2	1	1	15	1.5 %
VQ_Counter_Interupts_Long	0	0	0	0	0	0	0	0	
VQ_Counter_Interupts_Short	0	0	0	1	2	0	0	3	
VQ_Counter_THD_U_L1	2	3	1	2	3	2	2	15	1.5 %
VQ_Counter_THD_U_L2	9	8	12	8	14	7	10	68	6.7 %
VQ_Counter_THD_U_L3	1	1	4	3	1	2	1	13	1.3 %
VQ_Counter_THD_I_L1	4	2	1	2	1	1	2	13	1.3 %
VQ_Counter_THD_I_L2	2	1	2	2	3	4	1	15	1.5 %
VQ_Counter_THD_I_L3	1	2	3	1	2	2	1	12	1.2 %
VQ_Counter_Sags	6	7	4	1	5	7	3	33	
VQ_Counter_Swells	0	1	2	1	1	0	2	7	

Table 26: An example of read out of the occurrence counter logger.

The interval of logging can be configured to daily, weekly or monthly.

4.9.9 Power factor

The OMNIPOWER meter also measures the power factor for each phase. The values are available for display readout and the instantaneously values can also be read on request. Finally it is possible to add power factor measurement in the analysis logger.

4.9.10 Neutral fault detection

OMNIPOWER is able to detect if the neutral connection (N) on the supply side is disconnected. This is also called neutral fault. The purpose of the neutral fault detection is to register if the attached electronic equipment could be exposed to overvoltage which can damage the equipment and/or cause injury. Neutral fault detection only applies to the three-phase, 4-wire meter type.

In Figure 28, it is illustrated how the OMNIPOWER meter detects neutral faults related to the supply side, but not on the demand (or consumer) side.

OMNIPOWER direct and CT meters

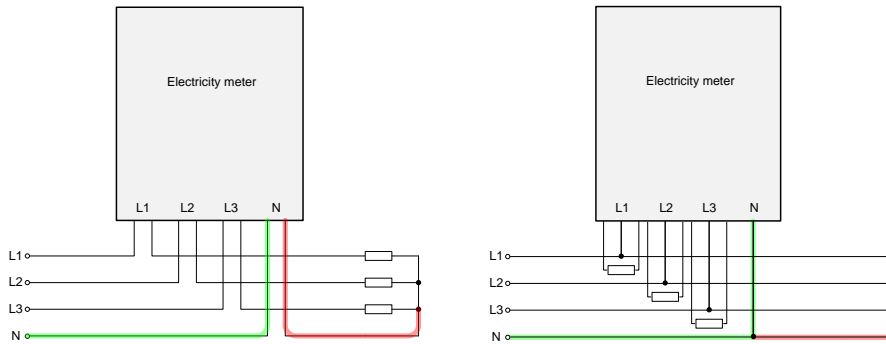

Figure 28: Neutral fault detection for three-phase and CT meters.

The functionality behind the neutral fault detection is based on voltage measurements and voltage thresholds, which is described in the following.

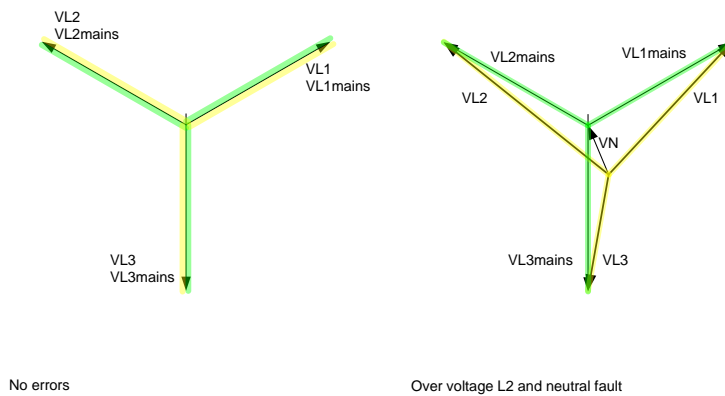
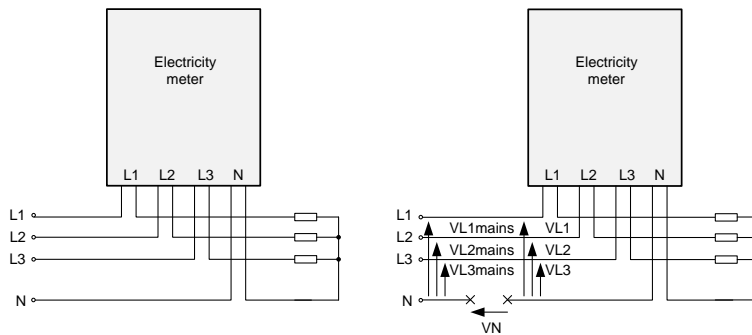

Figure 29: Neutral fault measurement principle.

Figure 29 shows a situation without neutral fault and one with neutral fault. When the neutral fault is present, the load is asymmetric, and the neutral fault voltage V_N occurs. The green vectors indicate the phase voltages on the grid. The yellow vectors indicate the phase voltages measured by the meter.

The neutral fault is detected when the following three conditions are present:

- 1) Two of the phase voltages V_{L1} , V_{L2} and V_{L3} must be above the threshold voltage V_{LhiTh} . The default value is 253 V.
- 2) One of the phase voltages V_{L1} , V_{L2} and V_{L3} must be below the threshold voltage V_{LloTh} . V_{LloTh} is equal to $230V - V_{NTh}$, where V_{NTh} is set to 40, i.e. $V_{LloTh} = 190$ V.
- 3) Condition 1 and 2 must be present in a time period longer than the time period called "neutral fault time". The default value is 60 seconds.

Under some conditions, a neutral fault is not detected. In a situation with symmetric load, the neutral fault voltage V_N will theoretically be zero volts and neutral fault will not be detected, even if the neutral is missing. In Figure 30, a neutral fault is not detected in the white areas.

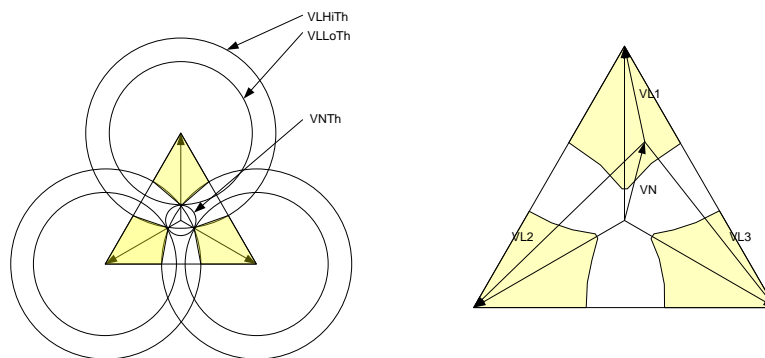

Figure 30: Neutral fault detection range.

To the left in Figure 30, the yellow areas indicate when the neutral fault will be detected. To the right in Figure 30, a situation is shown where the neutral fault is not detected since the conditions are as follows:

- $V_{L1} < V_{LloTh}$
- $V_{L2} > V_{LhiTh}$
- $V_{L3} > V_{LhiTh}$

The parameters V_{NTh} , V_{LhiTh} and the neutral fault time can be configured with the registers (shown with default values):

- V_{NTh} = 40 VAC
- V_{LhiTh} = 253 VAC
- NeutralFaultTime = 60 seconds

4.9.10.1 Neutral fault logger (1.1.99.98.12.255)

OMNIPower has a logger for neutral faults event where every event is registered with a timestamp. The neutral fault event logger has a depth of 45 log entries.

In a smart metering system, it is possible for the meter, in case of a neutral fault, to send a push alarm to the MDM system and in this way to warn the utility of the situation as quickly as possible.

OMNIPOWER direct and CT meters

In meters with integrated breakers, there is furthermore the possibility to disconnect the breaker in the meter in case of neutral fault detection.

4.10 Other smart grid functionalities

OMNIPOWER is developed to meet the future smart grid requirements. This is underlined by the power quality measurements, but also by a number of additional functionalities such as meter firmware upload, integration of push alarms, and control of in-home relays and the implementation of Multi-Utility Controller in the meter.

The functions are described in this section.

4.10.1 Firmware upload

It is possible to upload new meter firmware remotely with Kamstrup's OMNIA Suite. This functionality is developed according to WELMEC Software guide 7.2 and is approved in accordance with the MID type approval of the meter. Please contact Kamstrup for further information regarding the firmware upload functionality.

4.10.2 Alarm handling/push alarms

The meter can be configured to give an alarm when specific events are registered by the meter. As the alarm is pushed from the meter, the term "push alarm" is used. Events that can be configured to generate push alarms are:

- Magnetic detection
- Tamper detection
- Internal meter error
- Undervoltage and overvoltage detection
- Missing phase voltage detection
- Neutral fault detection.

The alarms are transmitted through the OMNICON communication network or to the module port. For further details about alarms and configuration, please contact Kamstrup.

4.10.3 All phase power outage alarm

Additional to previous section, Variant 2 OMNIPOWER meters introduce an alarm notification, also called "Last gasp" in case of a total power outage, i.e. a power outage on all phases on the grid side of the meter.

In case of an all phase power outage, affected OMNIPOWER meters with internal radio will broadcast a "last gasp" alarm, which is relayed through the radio network to the OMNIA System. However, a meter which is affected itself by the power outage will not be able to repeat "Last gasp" alarms from nearby located meters.

4.10.4 Control of external load relays

As an option, it is possible to install a two-relay load control module in the meter. The load control relays can be used to control the consumer's installation. The control of the relays on the module can be done in two ways:

- By predefined (configurable) load control plans managed by the meter. The plan can be set independently for each meter and can also be set to follow a specific tariff plan. Load control plans can be remotely updated from the OMNISOFT VisionAir MDM.¹⁰
- By remote commands, sent from a smart metering system. The system must send a command to the meter to switch the relays on and off “on demand”.

For more details about how to configure the load control, see “Load control configuration”, p. 73.

4.10.5 Multi-utility options

It is possible to install a Multi-Utility Controller (MUC) module in OMNIPOWER meters. With this, it is possible to read out consumption data from nearby flow meters as heat, water or gas meters, and afterwards send the data to OMNISOFT VisionAir using the OMNICON network. The setup is shown in figure 31.

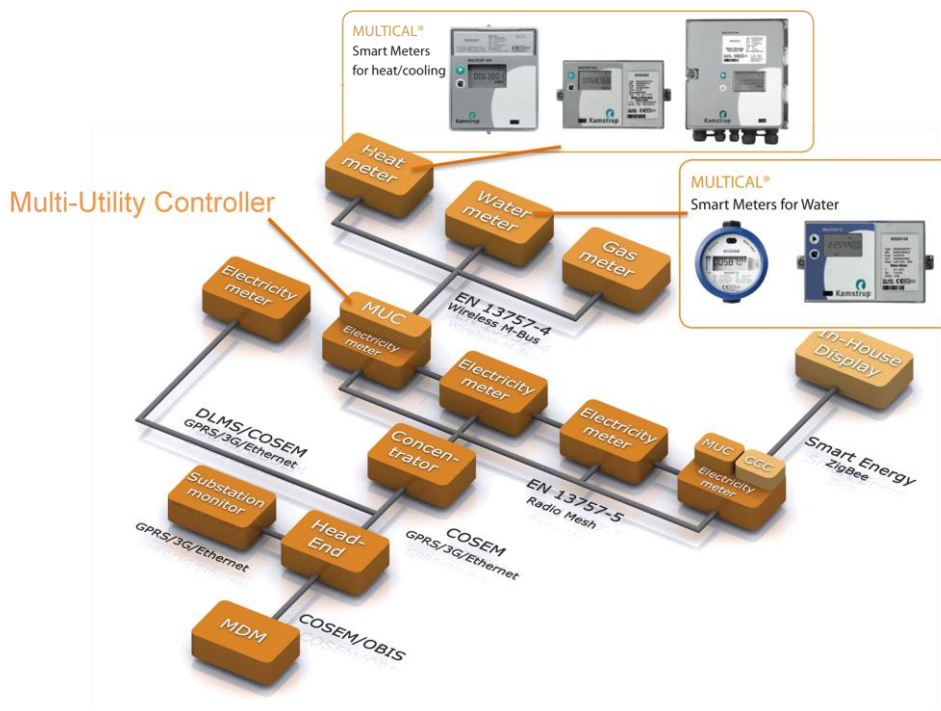

Figure 31: Multi-Utility Controller in OMNIPOWER.

For more information about the MUC module and the flow meter data which can be accessed, please contact Kamstrup A/S.

¹⁰Due to an eventually preprogrammed delay in the meter on the relay-shift, it is important to restart the meter (on/off) when the time is set correctly in the meter. This places the relays in the correct position and stops the delay timer.

OMNIPOWER direct and CT meters

4.10.6 Miscellaneous use

As default, the meter has an S0 pulse output (described in "S0 output", p. 59) and two available I/O (input/output) ports on the module interface. The use of one or both I/O ports in the module area requires that the meter is equipped with a module that supports the wanted functionality.

4.10.7 Pulse inputs in the module area

The pulse inputs in the module area (module I/O) can be configured for the following functionalities:

- Tariff control, see also Table 10
- Pulse input from other units
- Alarm input for the registration of an external alarm.

The pulse input accumulates pulses in the pulse input register. If this register is shown in the display, it is updated every 10 seconds. It is possible to scale the reading of the pulse input by a "pulse division factor" in the range from 0.100 to 1000.000 units per pulse.

The maximum permissible frequency for input pulses is 25 Hz.

In relation to the pulse input register, the unit for the register can be set to the following.

- kWh
- m³
- l
- "None"

4.10.7.1 Example of pulse input from a water meter

A water meter emits 1 pulse per 25 l. The required reading in the electricity meter's display is m³ without decimals. 1000 l = 1 m³, 1000 / 25 = 40 ⇒ pulse division factor to be set to 40.

The electricity meter count will be incremented by one at every 40 pulses, i.e. indication in m³ without decimals.

The most frequently used pulse values appear from Table 27.

Pulse value l/Imp	Pulse value Imp/m ³	Pulse division factor Display indication in "m ³ "	Pulse division factor Display indication in "l"
100	10	10	-
50	20	20	-
25	40	40	-
10	100	100	0.1
5.0	200	200	5
2.5	400	400	2.5
1.0	1000	1000	1
1000	1	1	1000

Table 27: Pulse values for water meters.

4.10.8 Examples of pulse input from an electricity meter

Table 28 shows a similar list of pulse values for electricity meters.

Pulse value Wh/imp	Pulse value Imp/kWh	Pulse division factor Display indication in kWh
100000	0.01	-
10000	0.1	0.1
1000	1	1
16.67	60	60
13.33	75	75
8.333	120	120
4.167	240	240
2.941	340	340
2.083	480	480
1.667	600	600
1.000	1000	1000
0.100	10000	-

Table 28: Pulse values for electricity meters.

4.10.9 Pulse outputs in module area

The pulse outputs in the module area can be configured for pulse outputs for both active and reactive energy. As standard, the pulse outputs send 1pulses/kWh, but can be configured between 1 – 1000 pulse/kWh. In addition, the pulse width can be configured for 30 or 80 msecs.

When selecting pulse/kWh-factor and pulse width, be aware that the number of pulses at max load is not exceeding the number which the meter is able to send via the pulse output.

Pulse value Imp/kWh, Imp/kvar	Pulse duration/ pulse pause	
	30 msecs.	80 msecs.
1	100A	100A
10	100A	100A
100	100A	100A
1000	86A	32A

Table 29: Maximum load current at different pulse/kWh values.

4.10.10 S0 output

OMNIPOWER direct and CT meters

The S0 output provides pulses/kWh permanently, and the pulses are synchronized with the S0 LED. See Electrical specifications p.9 for number of pulses/kWh.

The S0 output is specified according to the DIN 43864 standard, and Figure 32 shows the placement of the S0 output connector.

The maximum voltage that can be connected to the S0 output is 27 V DC (at 1 k Ω), and the maximum current through the output is 27 mA.

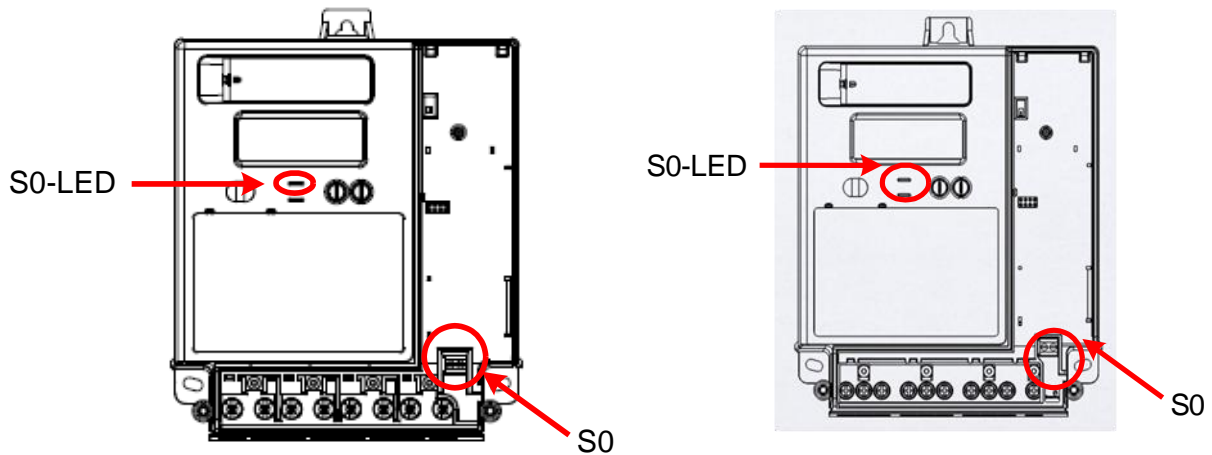

Figure 32: The S0 output on a three-phase and a CT meter.

The S0-LED will in normal operation always flash according to the consumption, i.e. A+. However, it can change if the meter switches to verification mode. Then it will follow the activated quadrant.

Table 30 lists the technical specification for the S0 output.

The status of the pulse sensor	Test conditions		Test data
	Supply voltage	Internal resistance	
	U_B	R_V	Current through the S0 output
On (active)	18 V DC	1 k Ω	$i > 10$ mA
Off (inactive)	27 V DC	1 k Ω	$i < 2$ mA

Table 30: S0 technical specification.

On the three-phase direct meter with auxiliary power supply (APS), the S0 output is not available. S0 output can then only be achieved as a module interface.

4.10.11 Auxiliary power supply (APS)

The three-phase direct meter can optionally be configured with an APS functionality. The function allows to supply the meter with 230VAC on a separate input as shown in Figure 33. The functionality is useful when an external breaker is installed before the meter in an installation.

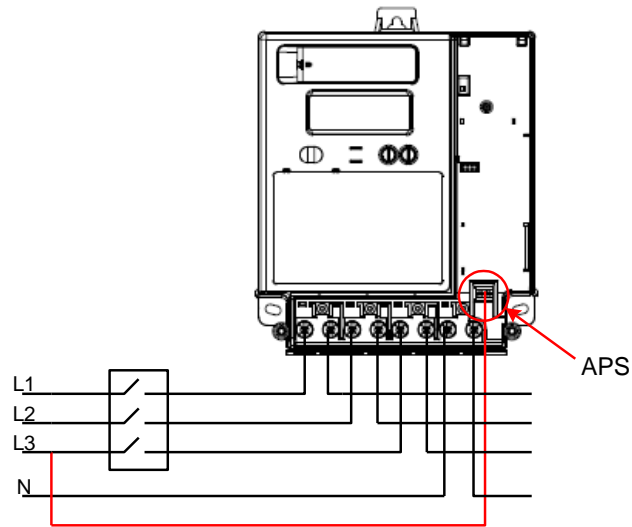

Figure 33: APS functionality.

Note!! It is important that the APS is connected to phase L3.

When the meter is configured for APS, it does not have an S0 output as the connector is used for the 230 V APS.

5 Ordering specification

This section contains order information on all aspects of the OMNIPOWER meter including hardware, software and all other relevant configurations such as customer label, sealing, packaging, etc.

5.1 Meter configuration

The meter configuration is divided into two main parts:

- **Hardware configuration:** Specifies the meter regarding number of phases, current specification, internal breaker, integrated radio, etc. The hardware configuration also defines the meter type number which is printed on the meter front.
- **Software configuration:** Specifies the configurable setup and meter variables including display setup, smart disconnect settings, tariff and load control plans, voltage quality parameters, etc.

Regarding the software configuration, a number of related extended configuration options are available. Each of them has a related separate order form. This relates to the following parameters:

- Display setup
- Tariff setup
- Load control setup
- Smart disconnect
- Sealable push-button setup
- Analysis logger setup
- 1107 setup.

The different order forms are shown in the following sections.

5.2 Hardware configuration

	X1	X2	X3	X4	X5	X6	X7	X8	X9	X10	X11	X12	X13	X14	X15	X16
68	<input type="checkbox"/>	<input type="checkbox"/>	<input type="checkbox"/>	<input type="checkbox"/>	<input type="checkbox"/>	<input type="checkbox"/>	<input type="checkbox"/>	<input type="checkbox"/>	<input type="checkbox"/>	<input type="checkbox"/>	<input type="checkbox"/>	<input type="checkbox"/>	<input type="checkbox"/>	<input type="checkbox"/>	<input type="checkbox"/>	<input type="checkbox"/>
X1 – Meter type																
OMNIPOWER single-phase	6															
OMNIPOWER CT	5															
OMNIPOWER three-phase	4															
X2 – Type no. version																
OMNIPOWER		1														
X3 – Housing																
Standard			1													
ST-meter (BS7856) Single-phase			2													
X4 – Measuring systems																
1 system				1												
2 systems (Aron)				2												
3 systems				3												
X5 – Current range																
Direct meters CT meters																
5(100)A					1											
5(65)A					4											
					5											
10(60)A					6											
10(80)A					7											
5(80)A					8											
X6 – Accuracy class																
Direct meters CT meters																
Class A								A								
Class B								B								
								C								
Class 2								2								
Class 1								1								
								5								
X7 – Generation																
Generation D ¹²								D								
Generation N ¹³								N								
X8 – Variant																
1 st Variant									1							
2 nd variant ¹¹									2							
X9 – Energy type																
A+										1						
A+/A-										2						
A+/R+ ¹²										3						
A+/A-/R+/R-										4						
X10 – Breaker																
No breaker																0
Dual breaker ¹³ (single-phase only)																2

¹¹ Does not support DLMS or 1107 communication protocol.

¹² OMNIPOWER CT meter only.

¹³ OMNIPOWER direct meters only.

OMNIPOWER direct and CT meters

Standard breaker ¹³	3			
X11 – Communication				
No radio		0		
Radio (<i>For OMNIA</i>)		1		
X12 – Supply backup				
Supercap ¹³			0	
Supercap + battery			1	
X13 – Interface				
S0 output				1
APS ¹³				2
X14X15X16 – Country code				
Denmark				010
Denmark				011
Denmark				012
Russia				025
Spain				031
Turkey				035
Croatia				036
Serbia				037
Norway				040
Slovakia				042
Czech Republic				043
Hungary				044
Latvia				045
Lithuania				049
United Kingdom				050
Austria				055
Austria				056
Switzerland (Italian part)				059
Estonia				061
Switzerland (German part)				063
Poland				064
Switzerland (French part)				065
Iceland				067
Germany				070
Belgium				078
The Netherlands				080
Finland				084
Finland (Aland island)				086
Sweden				090
Saudi Arabia				110
South Africa				120
Ghana				121
Chile				151

5.3 Software configuration

		Z1	Z2	Z3	Z4
Z1 – Decimals in display					
Direct meters	CT meters				
7.0	7.0	1			
6.1	7.1	2			
7.2	7.2	3			
6.3	NA	4			
Z2 – LED configuration					
LED off at no consumption		1			
LED on at no consumption		2			
Z3 – Primary module configuration					
	I/O 1	I/O 2			
No function	-	-	00		
4-tariff	Input	Input	01		
4-tariff inverted	Input	Input	02		
Pulse in / Alarm in	Input	Input	03		
Pulse in / Alarm in inverted	Input	Input	04		
Pulse in / A+ out	Input	Output	05		
R+ out / A+ out	Output	Output	06		
2-tariff / Alarm in	Input	Input	07		
2-tariff inverted / Alarm in	Input	Input	08		
2-tariff / Alarm in inverted	Input	Input	09		
2-tariff inverted / Alarm in inverted	Input	Input	10		
2-tariff / A+ out	Input	Output	11		
2-tariff inverted / A+ out	Input	Output	12		
Pulse in / 2-tariff	Input	Input	13		
Pulse in / 2-tariff inverted	Input	Input	14		
Debiting stop pulse / -	Input	-	15		
A- out / A+ out	Output	Output	16		
Load control load / Status control	Input	Output	17		
Pulse in / Load tariff sync	Input	Output	18		
Pulse in inv. / Load tariff sync	Input	Output	19		
Pulse in / Load tariff sync inverted	Input	Output	20		
Pulse in inv. / Load tariff sync inverted	Input	Output	21		
4-tariff sync load control	Input	Input	22		
4-tariff sync load control inverted	Input	Input	23		
Load control 1 / Load control 2	Output	Output	26		
Pulse in / Load control	Input	Output	27		
Pulse in / Toggle Load control 1 & 2	Input	Output	28		
Earth fault ⁹	I2C	I2C	29		
Z4 - Integration period / load profile period					
15 min.				2	
30 min.				3	
60 min.				4	

OMNIPOWER direct and CT meters

	Z5	Z6	Z7	Z8
Z5 - Display configuration				
See the display order form or contact Kamstrup				
Z6 - Debiting stop date				
1.		01		
2.		02		
3.		03		
4.		04		
5.		05		
23.		23		
24.		24		
25.		25		
26.		26		
27.		27		
28.		28		
Z7 - Debiting logging interval				
None (externally controlled)			00	
Monthly			01	
Every second month, January			02	
Every second month, February			03	
Every third month, January			04	
Every third month, February			05	
Every third month, March			06	
Every six month, January			07	
Every six month, February			08	
Every six month, March			09	
Every six month, April			10	
Every six month, May			11	
Every six month, June			12	
Yearly, January			13	
Yearly, February			14	
Yearly, March			15	
Yearly, April			16	
Yearly, May			17	
Yearly, June			18	
Yearly, July			19	
Yearly, August			20	
Yearly, September			21	
Yearly, October			22	
Yearly, November			23	
Yearly, December			24	
Z8 - Pulse out length / alarm input				
30 ms pulse length / alarm input deactivated				1
30 ms pulse length / alarm input active				2
80 ms pulse length / alarm input deactivated				3
80 ms pulse length / alarm input active				4

	Z9	Z10	Z11	Z12
Z9 - Disconnect setup				
See the disconnect order form or contact Kamstrup				
No disconnect setup	000			
Default setup	001			
Z10 - Analysis logger setup				
See the analysis logger order form or contact Kamstrup				
Default setup		000		
Z11 - GMT				
0 London time			00	
1 + 1 Hour (DK/NO/SE/DE/FR/ES)			01	
2 + 2 Hours (FI)			02	
3 + 3 Hours			03	
4 + 4 Hours			04	
5 + 5 Hours			05	
6 + 6 Hours			06	
7 + 7 Hours			07	
8 + 8 Hours			08	
9 + 9 Hours			09	
10 + 10 Hours			10	
11 + 11 Hours			11	
12 + 12 Hours			12	
-11 - 11 Hours			13	
-10 - 10 Hours			14	
-9 - 9 Hours			15	
-8 - 8 Hours			16	
-7 - 7 Hours			17	
-6 - 6 Hours			18	
-5 - 5 Hours			19	
-4 - 4 Hours			20	
-3 - 3 Hours			21	
-2 - 2 Hours			22	
-1 - 1 Hours			23	
Z12 - Unit pulse input				
None				00
kWh				01
m3				02
L				03

OMNIPOWER direct and CT meters

	Z13	Z14	Z15	Z16	Z17	Z18	Z19	Z20
Z13 - Tariff control plan								
See the tariff order form or contact Kamstrup								
Tariff disabled	000							
Module port Control (<i>used for 230VAC input tariff control</i>)	001							
Register control	002							
Tariff control table	xxx							
Z14 – Load control plan								
See the load control order form or contact Kamstrup								
Load control disabled		000						
Register control		001						
Load control table		xxx						
Z15 - Daylight saving time / summer/winter time table								
None								
EU			000					
			001					
Z16 - Frequency code protocol								
None (<i>only for meters without Radio</i>)								
CH 318 RF				000				
EU 319 RF				318				
SE 326 RF				319				
SE 328 RF				326				
SE 329 RF				328				
NO 338 RF				329				
NO 339 RF				338				
DK 348 RF				339				
DK 349 RF				348				
FI 359 RF				349				
PL 369 RF				359				
AT 379 RF				369				
				379				
Z17 – Push-button 2 setup								
See the PB2 order form or contact Kamstrup								
No PB2 setup					000			
Z18 - 1107 configuration								
See the 1107 order form or contact Kamstrup								
Disabled						000		
Mode A and C, UD1						001		
Mode A and C, UD2						002		
Z19 - Breaker position								
Undefined (<i>only for meters without breakers</i>)								
Connected							0	
Disconnected							1	
							2	
Z20 – Calendar Setup								
See Calendar setup order form or contact Kamstrup								
No exception days								000
Exception day setup								xxx

Z21 Transformer ratio¹⁴					
5A / 5A	1A / 1A	001			
10A / 5A	2A / 1A	002			
15A / 5A	3A / 1A	003			
20A / 5A	4A / 1A	004			
50A / 5A	10A / 1A	010			
75A / 5A	15A / 1A	015			
100A / 5A	20A / 1A	020			
120A / 5A	24A / 1A	024			
150A / 5A	30A / 1A	030			
160A / 5A	32A / 1A	032			
200A / 5A	40A / 1A	040			
300A / 5A	60A / 1A	060			
500A / 5A	100A / 1A	100			
1000A / 5A	200A / 1A	200			
1500A / 5A	300A / 1A	300			
2000A / 5A	400A / 1A	400			
3000A / 5A	600A / 1A	600			
Z22 Transformer ratio (unlocked / locked)¹⁴					
Unlocked			1		
Locked			2		
Z23 Load profile, based on¹⁴					
Primary energy				1	
Secondary energy				2	
Z24 Pulse output (module)¹⁴					
Based on secondary energy					0
Based on primary energy					1
Z25 Debiting 2 interval					
Daily					1
Weekly					2
Monthly					3

¹⁴ OMNIPower CT meter only.

OMNIPOWER direct and CT meters

5.4 Display configuration

The possible display readings depend on the chosen energy. In addition, it must be considered if leading zeroes should be indicated in the energy display, and if OBIS/EDIS codes and actual quadrant indication are required. Display readings are shown with OBIS codes.

Description		OBIS	Auto scroll	Manual scroll	Battery	Manual Utility
Active positive energy	A+	1.8.0				
Active negative energy	A-	2.8.0				
Reactive positive energy	R+	3.8.0				
Reactive negative energy	R-	4.8.0				
A+, A- active energy numerical (A1423)	-	15.8.0				
Nett active energy(A+ - A-)	NET	16.8.0				
Reactive energy R1	R1	5.8.0				
Reactive energy R2	R2	6.8.0				
Reactive energy R3	R3	7.8.0				
Reactive energy R4	R4	8.8.0				
Apparent positive energy	E+	9.8.0				
Apparent negative energy	E-	10.8.0				
Active positive energy, T1	A+/T1	1.8.1				
Active positive energy, T2	A+/T2	1.8.2				
Active positive energy, T3	A+/T3	1.8.3				
Active positive energy, T4	A+/T4	1.8.4				
Active positive energy, T5	A+/T5	1.8.5				
Active positive energy, T6	A+/T6	1.8.6				
Active positive energy, T7	A+/T7	1.8.7				
Active positive energy, T8	A+/T8	1.8.8				
Active negative energy, T1	A-/T1	2.8.1				
Active negative energy, T2	A-/T2	2.8.2				
Active negative energy, T3	A-/T3	2.8.3				
Active negative energy, T4	A-/T4	2.8.4				
Active negative energy, T5	A-/T5	2.8.5				
Active negative energy, T6	A-/T6	2.8.6				
Active negative energy, T7	A-/T7	2.8.7				
Active negative energy, T8	A-/T8	2.8.8				
Reactive positive energy, T1	R+/T1	3.8.1				
Reactive positive energy, T2	R+/T2	3.8.2				
Reactive positive energy, T3	R+/T3	3.8.3				
Reactive positive energy, T4	R+/T4	3.8.4				
Reactive positive energy, T5	R+/T5	3.8.5				
Reactive positive energy, T6	R+/T6	3.8.6				
Reactive positive energy, T7	R+/T7	3.8.7				
Reactive positive energy, T8	R+/T8	3.8.8				
Reactive negative energy, T1	R-/T1	4.8.1				
Reactive negative energy, T2	R-/T2	4.8.2				
Reactive negative energy, T3	R-/T3	4.8.3				
Reactive negative energy, T4	R-/T4	4.8.4				
Reactive negative energy, T5	R-/T5	4.8.5				
Reactive negative energy, T6	R-/T6	4.8.6				
Reactive negative energy, T7	R-/T7	4.8.7				
Reactive negative energy, T8	R-/T8	4.8.8				
Resettable counter, Active positive energy	A+/TRIP	1.128.0				
Resettable counter, Active negative energy	A-/TRIP	2.128.0				
Resettable counter, Reactive pos. energy	R+/TRIP	3.128.0				
Resettable counter, Reactive neg. energy	R-/TRIP	4.128.0				
Resettable counter, Apparent pos. energy	E+/TRIP	9.128.0				
Resettable counter, Apparent neg. energy	E-/TRIP	10.128.0				
Active positive energy phase L1	A+/L1	21.8.0				
Active positive energy phase L2	A+/L2	41.8.0				
Active positive energy phase L3	A+/L3	51.8.0				
Active negative energy phase L1	A-/L1	22.8.0				
Active negative energy phase L2	A-/L2	42.8.0				

Description		OBIS	Auto scroll	Manual scroll	Battery	Manual Utility
Active negative energy phase L3	A-/L3	52.8.0				
Actual active positive power	P+	1.7.0				
Actual active negative power	P-	2.7.0				
Actual reactive positive power	Q+	3.7.0				
Actual reactive negative power	Q-	4.7.0				
Apparent positive power	S+	9.7.0				
Apparent negative power	S-	10.7.0				
Active positive max power	P+M	1.6.0				
Time stamp active positive max power	TIME/DATE	1.6.0				
Active negative max power	P-M	2.6.0				
Reactive positive max power	Q+M	3.6.0				
Time stamp reactive positive max power	TIME/DATE	3.6.0				
Reactive negative max power	Q-M	4.6.0				
Active positive max power tariff 1	P+M/T1	1.6.1				
Time stamp active positive max power tariff 1	TIME/DATE	1.6.1				
Active positive max power tariff 2	P+M/T2	1.6.2				
Time stamp active positive max power tariff 2	TIME/DATE	1.6.2				
Reactive positive max power, T1	Q+M/T1	3.6.1				
Time stamp reactive pos. max power, T1	TIME/DATE	3.6.1				
Reactive positive max power, T2	Q+M/T2	3.6.2				
Time stamp reactive pos. max power, T2	TIME/DATE	3.6.2				
Accumulated active positive max power	P+M/ACC	1.2.0				
Accumulated active negative max power	P-M/ACC	2.2.0				
Accumulated reactive positive max power	Q+M/ACC	3.2.0				
Accumulated reactive negative max power	Q-M/ACC	4.2.0				
Accumulated active positive max power tariff 1	P+M1/ACC	1.2.1				
Accumulated active positive max power tariff 2	P+M2/ACC	1.2.2				
Pulse input	-	0.128.1				
Display test	-	-				
Meter number 1	NUM/1	0.0.1				
Meter number 2	NUM/2	0.0.2				
Meter number 3	NUM/3	0.0.3				
Meter serial number	SER/NUM	96.1.0				
Special data 1	SPC/1	0.130.1				
Actual voltage phase L1	U-L1	32.7.0				
Actual voltage phase L2	U-L2	52.7.0				
Actual voltage phase L3	U-L3	72.7.0				
Actual current phase L1	I-L1	31.7.0				
Actual current phase L2	I-L2	51.7.0				
Actual current phase L3	I-L3	71.7.0				
Date and Time	TIME/DATE	1.0.0				
Number of debiting periods	RST	0.1.0				
Actual positive power phase L1	P+/L1	21.7.0				
Actual positive power phase L2	P+/L2	41.7.0				
Actual positive power phase L3	P+/L3	61.7.0				
Historical data	-	98.1.0				
Load profile data	-	99.1.0				
Power threshold value	PTH	96.51.1				
Power threshold counter	PTH/CNT	95.51.2				
Hour counter	HRS	96.8.0				
Call	CALL	-				
ROM checksum	CSUM	96.54.1				
Software number		0.2.0				
Meter status	INFO	97.97.0				
Active positive max. power per day.	MAX	1.16.0				
RTC active positive max. power per day.	TIME/DATE	1.16.0				
Active positive min. power per day.	MIN	1.13.0				
RTC active positive min. power per day.	TIME/DATE	1.13.0				
Load profile event status		-				
Power factor L1	PF-1	33.7.0				
Power factor L2	PF-2	53.7.0				
Power factor L3	PF-3	73.7.0				
Power factor Total	PF	13,7.0				
Frequency	FREQ	14.7.0				
Total harmonic distortion, Voltage L1	THD/U-L1	32.7.124				

OMNIPOWER direct and CT meters

Description		OBIS	Auto scroll	Manual scroll	Battery	Manual Utility
Total harmonic distortion, Voltage L2	THD/U-L2	52.7.124				
Total harmonic distortion, Voltage L3	THD/U-L3	72.7.124				
For direct meters only						
Manual disconnect						
Active positive energy Prepayment		130.0.0				
Active positive energy Prepayment - credit		130.0.1				
Total harmonic distortion, Current L1	THD/I-L1	31.7.124				
Total harmonic distortion, Current L2	THD/I-L2	51.7.124				
Total harmonic distortion, Current L3	THD/I-L3	71.7.124				
For CT meters only						
Transformer ratio	CTR	0.4.2				
Secondary active positive energy	A+ S	1.8.0				
Secondary active negative energy	A- S	2.8.0				
Secondary reactive positive energy	R+ S	3.8.0				
Secondary reactive negative energy	R- S	4.8.0				
Secondary reactive energy R1	R1 S	5.8.0				
Secondary reactive energy R4	R4 S	8.8.0				
Secondary active positive energy, T1	A+ S/T1	1.8.1				
Secondary active positive energy, T2	A+ S/T2	1.8.2				
Secondary active positive energy, T3	A+ S/T3	1.8.3				
Secondary active positive energy, T4	A+ S/T4	1.8.4				
Secondary active positive energy, T5	A+ S/T5	1.8.5				
Secondary active positive energy, T6	A+ S/T6	1.8.6				
Secondary active positive energy, T7	A+ S/T7	1.8.7				
Secondary active positive energy, T8	A+ S/T8	1.8.8				
Secondary active negative energy, T1	A- S/T1	2.8.1				
Secondary active negative energy, T2	A- S/T2	2.8.2				
Secondary active negative energy, T3	A- S/T3	2.8.3				
Secondary active negative energy, T4	A- S/T4	2.8.4				
Secondary active negative energy, T5	A- S/T5	2.8.5				
Secondary active negative energy, T6	A- S/T6	2.8.6				
Secondary active negative energy, T7	A- S/T7	2.8.7				
Secondary active negative energy, T8	A- S/T8	2.8.8				
Secondary reactive positive energy, T1	R+ S/T1	3.8.1				
Secondary reactive positive energy, T2	R+ S/T2	3.8.2				
Secondary reactive positive energy, T3	R+ S/T3	3.8.3				
Secondary reactive positive energy, T4	R+ S/T4	3.8.4				
Secondary reactive positive energy, T5	R+ S/T5	3.8.5				
Secondary reactive positive energy, T6	R+ S/T6	3.8.6				
Secondary reactive positive energy, T7	R+ S/T7	3.8.7				
Secondary reactive positive energy, T8	R+ S/T8	3.8.8				
Secondary reactive negative energy, T1	R- S/T1	4.8.1				
Secondary reactive negative energy, T2	R- S/T2	4.8.2				
Secondary reactive negative energy, T3	R- S/T3	4.8.3				
Secondary reactive negative energy, T4	R- S/T4	4.8.4				
Secondary reactive negative energy, T5	R- S/T5	4.8.5				
Secondary reactive negative energy, T6	R- S/T6	4.8.6				
Secondary reactive negative energy, T7	R- S/T7	4.8.7				
Secondary reactive negative energy, T8	R- S/T8	4.8.8				

Table 31: List of available display readings (5811-2371 Rev D1).

5.5 Tariff control configuration

Please contact Kamstrup A/S for further information about configuration of tariffs.

5.6 Load control configuration

Please contact Kamstrup A/S for further information about configuration of load control.

5.7 Smart disconnect setup

Please contact Kamstrup A/S for further information about configuration of Smart Disconnect.

5.8 Sealable push-button configuration

As described in details in the document 5514XXXX the meter pushbutton has a number of functionalities. The right side positioned pushbutton can be configured regarding which functions are enabled or not. The configuration must be done in relation with the ordering of the meter. The configuration options for right side-positioned sealable push-button are listed in table 32.

Description	Enabled	Disabled
PB2 functionality		
Sub functions		
Debiting stop		
Set date and time		
Adjust time		
Set optical interface		
View manual utility display list		
Set meter number		
Release permanent tamper		
Module installation mode		
Manual selection of tariff plan		
Manual selection of load control plan		
Test of load control plan		

Remember to configure the display list

This function is for future use and is not available yet

This function is for future use and is not available yet

Table 32: List of available functions attached to the sealable push-button

This list is part of the OMNIPower meter configuration order form.

5.9 1107 protocol configuration

Please contact Kamstrup A/S for further information about configuration of 1107 protocol.

Finally there are a number of additional choices to be made regarding the ordering of the meter. These are described in the final sections.

OMNIPOWER direct and CT meters

5.10 Packing

The meters can be delivered in three ways:

- Boxes – 1 meter per box
- Boxes – 4 meters per box
- Pallets – 160 Three-phase meters or 250 Single-phase meters on a pallet.

5.10.1 Box solution

The meters are packed in boxes with either 1 or 4 in each box. 4pcs-boxed are placed on pallets with 40 boxes on each as shown.



5.10.2 Pallet solution



5.11 Customer labels

The label consists of two parts: a meter label describing the choices made under type number, and a customer label created on basis of the customer's wishes, and which the customer must approve before an order can be created to the customer.

Both label parts are engraved with laser on front of the meter.

Four standard customer labels without customer logo are available.

These standard customer labels are:

- 2019000 No bar code No meter number
- 2019001 Code 128 Meter number = serial number
- 2019002 2 of 5 interleaved Meter number = serial number
- 2019003 Code 39 Meter number = serial number

The following information is required for the creation of a new customer label:

Customer logo must be provided to the Kamstrup Electricity Product Group. The logo must be in black/white and in one of the following formats: JPG, WMF.

Information about the bar code type to use and its content, serial number, meter number, installation number, and the position of numbers and bar code must also be provided.

When all information is available, a draft is prepared which must be approved by the customer. The bar code should also be read by the customer in order to secure that his bar code reading device can read the bar code.

After approval, a customer label no. 2019XXX is selected, and the number is released in the Kamstrup ordering systems.

OMNIPOWER direct and CT meters

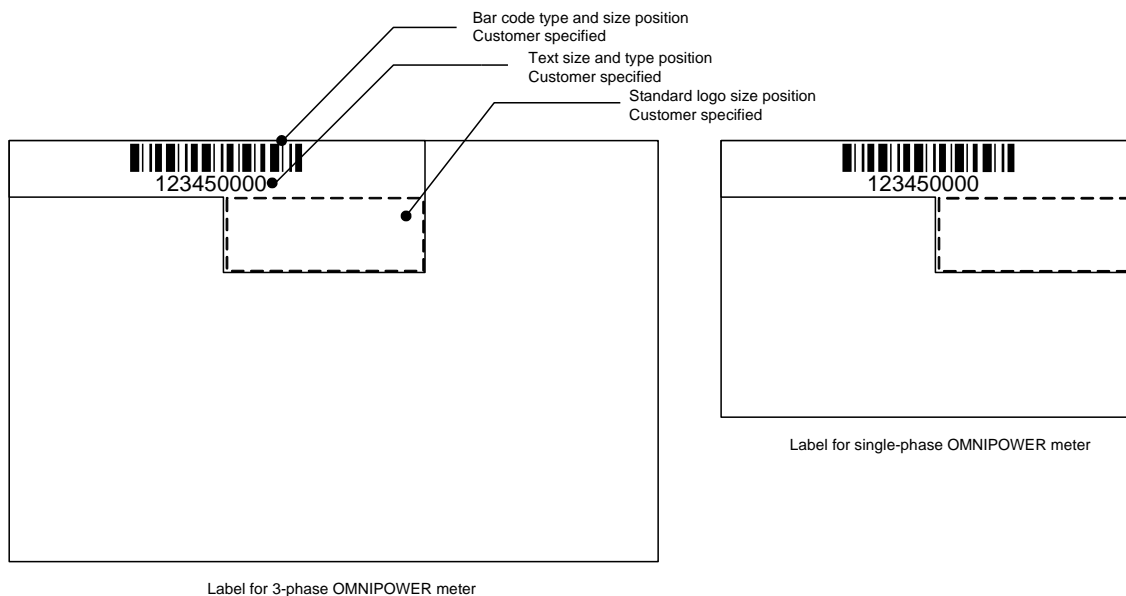

Figure 34: The customer label 2019xxx for OMNIPOWER three-phase and single-phase meters.

The customer label 2019xxx is of the same size on all meter types. This means that the same customer label can be used both on the single-phase and the three-phase meters.

5.12 Sealing

The meter is or can be sealed on different levels. The verification cover is “lifetime” sealed, i.e. the cover cannot be unsealed without damaging the cover and meter. The meter cover can be sealed by the utility as can the CCC module slot. Finally, the right push-button also offers sealing of its push action. Only authorized personnel is allowed to break the utility sealing.

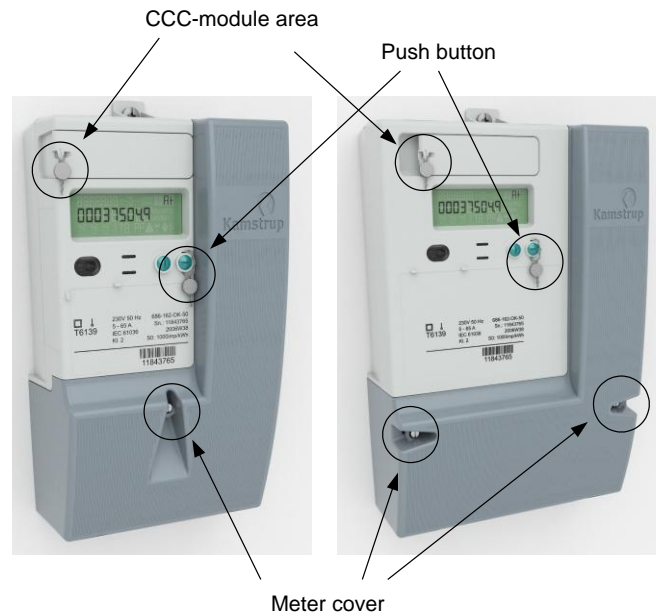

Figure 35: Sealing options for OMNIPOWER single-phase and three-phase meter.

5.13 Accessories

SOFTWARE TOOL

Configuration software, METERTOOL OMNIPOWER 68 99 570

VARIOUS

Three-phase covers

Standard meter cover (for three-phase meters) 59 60 315

Long meter cover, 60 mm (for three-phase meters) 59 60 316

Extra long meter cover, 100 mm (for three-phase meters) 59 60 317

Single-phase covers

Standard meter cover (for single-phase meters) 59 60 322

Long meter cover, 60 mm (for single-phase meters) 59 60 323

Extra long meter cover, 100 mm (for single-phase meters) 59 60 xxx (*not available yet*)

Single-phase covers for ST-meter

Standard meter cover (for single-phase meters) 59 60 617

Long meter cover, 60 mm (for single-phase meters) 59 60 323

OMNIPOWER direct and CT meters



Optical reading head with USB connector	66 99 099
Optical reading head with 9-pole D-sub connector	66 99 102
METERTOOL OMNIPOWER kit (RS232 module with USB connector)	68 30 017
Pins, 50 pcs.	68 50 102
Cable sockets, 50 pcs.	68 50 103