

8

7

6

5

4

3

2

1

NOTES: (UNLESS OTHERWISE SPECIFIED)

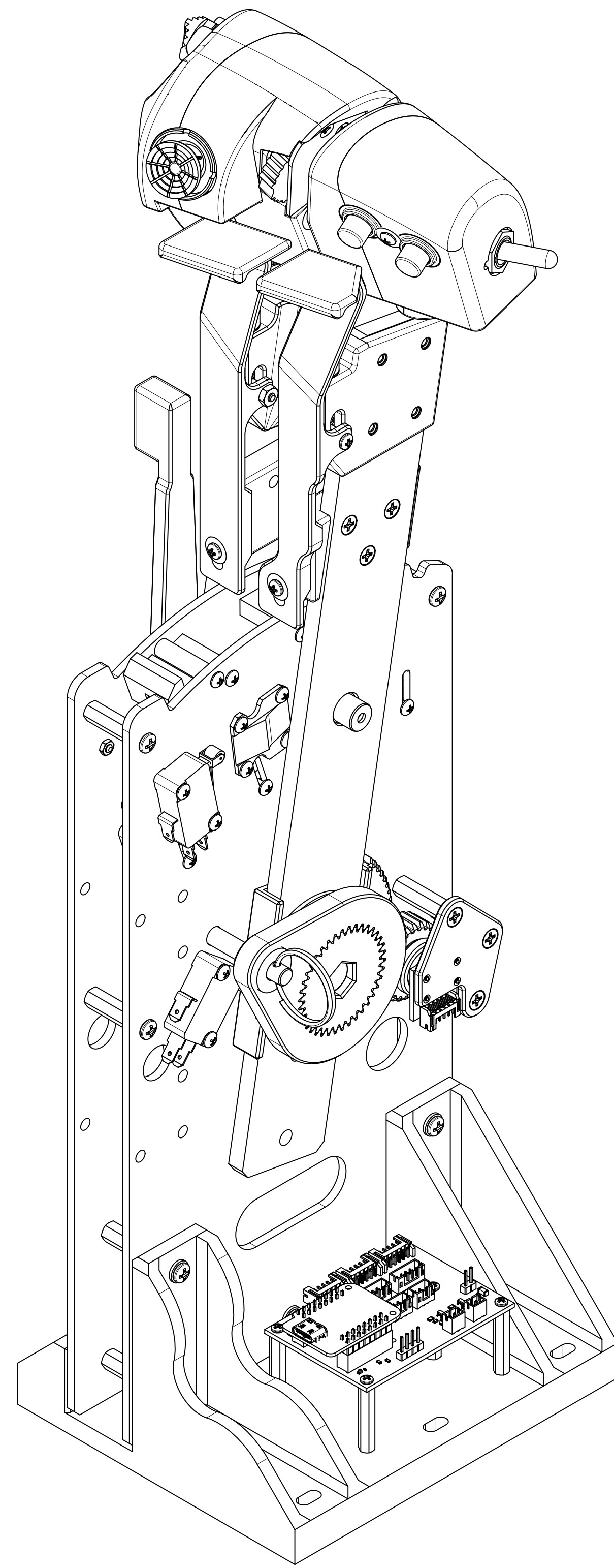

- 1. SPECIFICATIONS AND DOCUMENTS:
 - 1.1. ELECTRICAL CONNECTIONS SHALL BE IAW OH-INTERCONNECT.
- 2. ALL ITEMS NOT EXPLICITLY DEFINED IN THIS DRAWING ARE DEFINED BY THE MASTER CAD MODELS. ALL DIMENSIONS NOT DEFINED ON THIS DRAWING ARE CONTAINED WITHIN THE FOLLOWING MANUFACTURING FILES:
 - 2.1. FLAT PARTS: <MATERIAL>_<MATERIAL COLOR, IF APPLICABLE>_<THICKNESS, IN DECIMAL INCHES>_<PN>_<DESCRIPTION>_<REV>_V<VERSION NUMBER OF MODEL>.SVG
 - 2.2. FDM 3D PRINTED PARTS: FDM_<PN>_<DESCRIPTION>_<REV>_V<VERSION # OF MODEL>.3MF
 - 2.3. RESIN 3D PRINTED PARTS: RESN_<PN>_<DESCRIPTION>_<REV>_V<VERSION # OF MODEL>.3MF
 - 2.4. MACHINED OR BENT PARTS: <PN>_<DESCRIPTION>_<REV>_V<VERSION # OF MODEL>.STEP
 - 2.5. DECALS: <PN>_<DESCRIPTION>_<REV>_V<VERSION # OF MODEL>.PDF
- 3. FN 27 & 28 ARE INCLUDED WITH THEIR RESPECTIVE COMPONENTS, AND SHOULD NOT BE ORDERED SEPARATELY.
- 4. PRINT FN 5, 17 & 18 WITH A HIGH STRENGTH PRINT CONFIGURATION. (6X WALLS, 45% INFIL SUGGESTED.)
- 5. ALL MANUFACTURED PARTS OF FN 6 & 7 ASSYS AND THEIR SUBASSEMBLIES SHALL BE FINISHED IAW FED-STD-595, FS37038, BLACK.

REVISION HISTORY			
REV	DESCRIPTION	DATE	APPROVED
-	INITIAL RELEASE	5/10/2023	



-1 ASSY

PARTS LIST ON SHEET 2

UNLESS OTHERWISE SPECIFIED: DIMENSIONS ARE IN INCHES. DUAL DIMENSIONS ARE IN MILLIMETERS AND ENCLOSED IN SQUARE BRACKETS. INTERPRET DRAWING IAW ASME Y14.100-2017. INTERPRET DIM AND TOL IAW ASME Y14.5-2009. REMOVE ALL BURRS AND SHARP EDGES TO .05 MAX. DIMENSIONS APPLY BEFORE FINISH.	UOS INCH TOLERANCES ARE: DECIMALS: X ± .1 .XX ± .03 .XXX ± .010 ANGLES: MACHINED ± 5° LOCATING ± 5° FORMED ± 2° CHAMFERS ± 5° DRILLED HOLE DIAMETERS: .0135 - .125: +.004/- .001 .126 - .250: +.005/- .001 .251 - .500: +.006/- .001 .501 - .750: +.008/- .001 .751 - 1.000: +.010/- .001 1.001 - 2.000: +.012/- .001	 OPEN HORNET https://www.OpenHornet.com	TITLE	SIZE	DWG NO	REV
			ASSY, THROTTLE QUADRANT LEFT CONSOLE	D	OH4A9-1	-
DESIGNED J. STEENSEN 05/10/2023 CHECKED DRAWN J. STEENSEN 05/10/2023		SCALE 1:1.25 DO NOT SCALE DWG	SHEET 1/15			

8

7

6

5

4

3

2

1

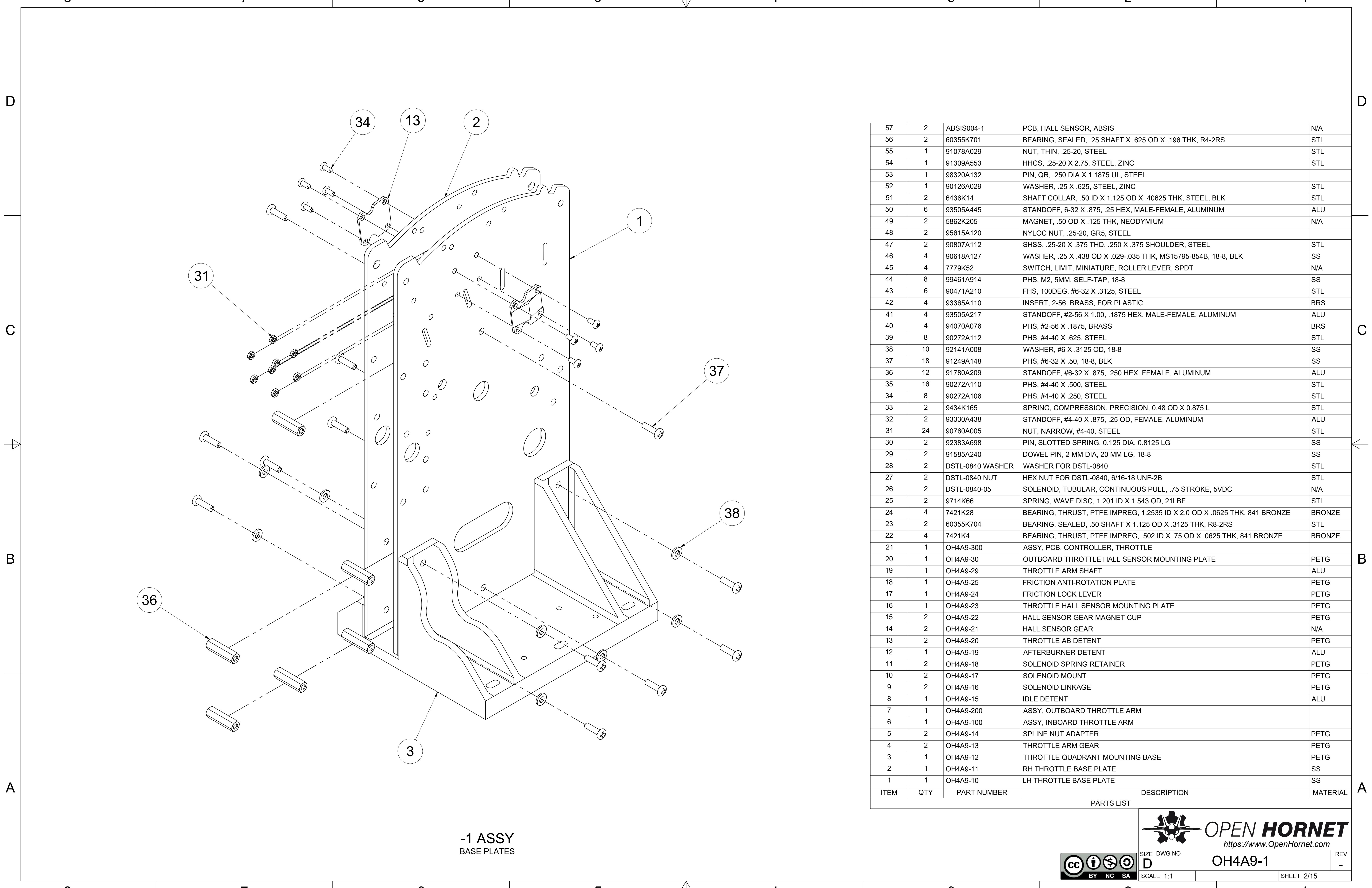

-1 ASSY
BASE PLATES

ITEM	QTY	PART NUMBER	DESCRIPTION	MATERIAL
57	2	ABSIS004-1	PCB, HALL SENSOR, ABSIS	N/A
56	2	60355K701	BEARING, SEALED, .25 SHAFT X .625 OD X .196 THK, R4-2RS	STL
55	1	91078A029	NUT, THIN, .25-20, STEEL	STL
54	1	91309A553	HHCS, .25-20 X 2.75, STEEL, ZINC	STL
53	1	98320A132	PIN, QR, .250 DIA X 1.1875 UL, STEEL	
52	1	90126A029	WASHER, .25 X .625, STEEL, ZINC	STL
51	2	6436K14	SHAFT COLLAR, .50 ID X 1.125 OD X .40625 THK, STEEL, BLK	STL
50	6	93505A445	STANDOFF, 6-32 X .875, .25 HEX, MALE-FEMALE, ALUMINUM	ALU
49	2	5862K205	MAGNET, .50 OD X .125 THK, NEODYMIUM	N/A
48	2	95615A120	NYLOC NUT, .25-20, GR5, STEEL	
47	2	90807A112	SHSS, .25-20 X .375 THD, .250 X .375 SHOULDER, STEEL	STL
46	4	90618A127	WASHER, .25 X .438 OD X .029-.035 THK, MS15795-854B, 18-8, BLK	SS
45	4	7779K52	SWITCH, LIMIT, MINIATURE, ROLLER LEVER, SPDT	N/A
44	8	99461A914	PHS, M2, 5MM, SELF-TAP, 18-8	SS
43	6	90471A210	FHS, 100DEG, #6-32 X .3125, STEEL	STL
42	4	93365A110	INSERT, 2-56, BRASS, FOR PLASTIC	BRS
41	4	93505A217	STANDOFF, #2-56 X 1.00, .1875 HEX, MALE-FEMALE, ALUMINUM	ALU
40	4	94070A076	PHS, #2-56 X .1875, BRASS	BRS
39	8	90272A112	PHS, #4-40 X .625, STEEL	STL
38	10	92141A008	WASHER, #6 X .3125 OD, 18-8	SS
37	18	91249A148	PHS, #6-32 X .50, 18-8, BLK	SS
36	12	91780A209	STANDOFF, #6-32 X .875, .250 HEX, FEMALE, ALUMINUM	ALU
35	16	90272A110	PHS, #4-40 X .500, STEEL	STL
34	8	90272A106	PHS, #4-40 X .250, STEEL	STL
33	2	9434K165	SPRING, COMPRESSION, PRECISION, 0.48 OD X 0.875 L	STL
32	2	93330A438	STANDOFF, #4-40 X .875, .25 OD, FEMALE, ALUMINUM	ALU
31	24	90760A005	NUT, NARROW, #4-40, STEEL	STL
30	2	92383A698	PIN, SLOTTED SPRING, 0.125 DIA, 0.8125 LG	SS
29	2	91585A240	DOWEL PIN, 2 MM DIA, 20 MM LG, 18-8	SS
28	2	DSTL-0840 WASHER	WASHER FOR DSTL-0840	STL
27	2	DSTL-0840 NUT	HEX NUT FOR DSTL-0840, 6/16-18 UNF-2B	STL
26	2	DSTL-0840-05	SOLENOID, TUBULAR, CONTINUOUS PULL, .75 STROKE, 5VDC	N/A
25	2	9714K66	SPRING, WAVE DISC, 1.201 ID X 1.543 OD, 21LBF	STL
24	4	7421K28	BEARING, THRUST, PTFE IMPREG, 1.2535 ID X 2.0 OD X .0625 THK, 841 BRONZE	BRONZE
23	2	60355K704	BEARING, SEALED, .50 SHAFT X 1.125 OD X .3125 THK, R8-2RS	STL
22	4	7421K4	BEARING, THRUST, PTFE IMPREG, .502 ID X .75 OD X .0625 THK, 841 BRONZE	BRONZE
21	1	OH4A9-300	ASSY, PCB, CONTROLLER, THROTTLE	
20	1	OH4A9-30	OUTBOARD THROTTLE HALL SENSOR MOUNTING PLATE	PETG
19	1	OH4A9-29	THROTTLE ARM SHAFT	ALU
18	1	OH4A9-25	FRICTION ANTI-ROTATION PLATE	PETG
17	1	OH4A9-24	FRICTION LOCK LEVER	PETG
16	1	OH4A9-23	THROTTLE HALL SENSOR MOUNTING PLATE	PETG
15	2	OH4A9-22	HALL SENSOR GEAR MAGNET CUP	PETG
14	2	OH4A9-21	HALL SENSOR GEAR	N/A
13	2	OH4A9-20	THROTTLE AB DETENT	PETG
12	1	OH4A9-19	AFTERBURNER DETENT	ALU
11	2	OH4A9-18	SOLENOID SPRING RETAINER	PETG
10	2	OH4A9-17	SOLENOID MOUNT	PETG
9	2	OH4A9-16	SOLENOID LINKAGE	PETG
8	1	OH4A9-15	IDLE DETENT	ALU
7	1	OH4A9-200	ASSY, OUTBOARD THROTTLE ARM	
6	1	OH4A9-100	ASSY, INBOARD THROTTLE ARM	
5	2	OH4A9-14	SPLINE NUT ADAPTER	PETG
4	2	OH4A9-13	THROTTLE ARM GEAR	PETG
3	1	OH4A9-12	THROTTLE QUADRANT MOUNTING BASE	PETG
2	1	OH4A9-11	RH THROTTLE BASE PLATE	SS
1	1	OH4A9-10	LH THROTTLE BASE PLATE	SS



OPEN HORNET
<https://www.OpenHornet.com>

SIZE D	DWG NO OH4A9-1	REV -
SCALE 1:1	SHEET 2/15	

8

7

6

5

4

3

2

1

D

C

B

A

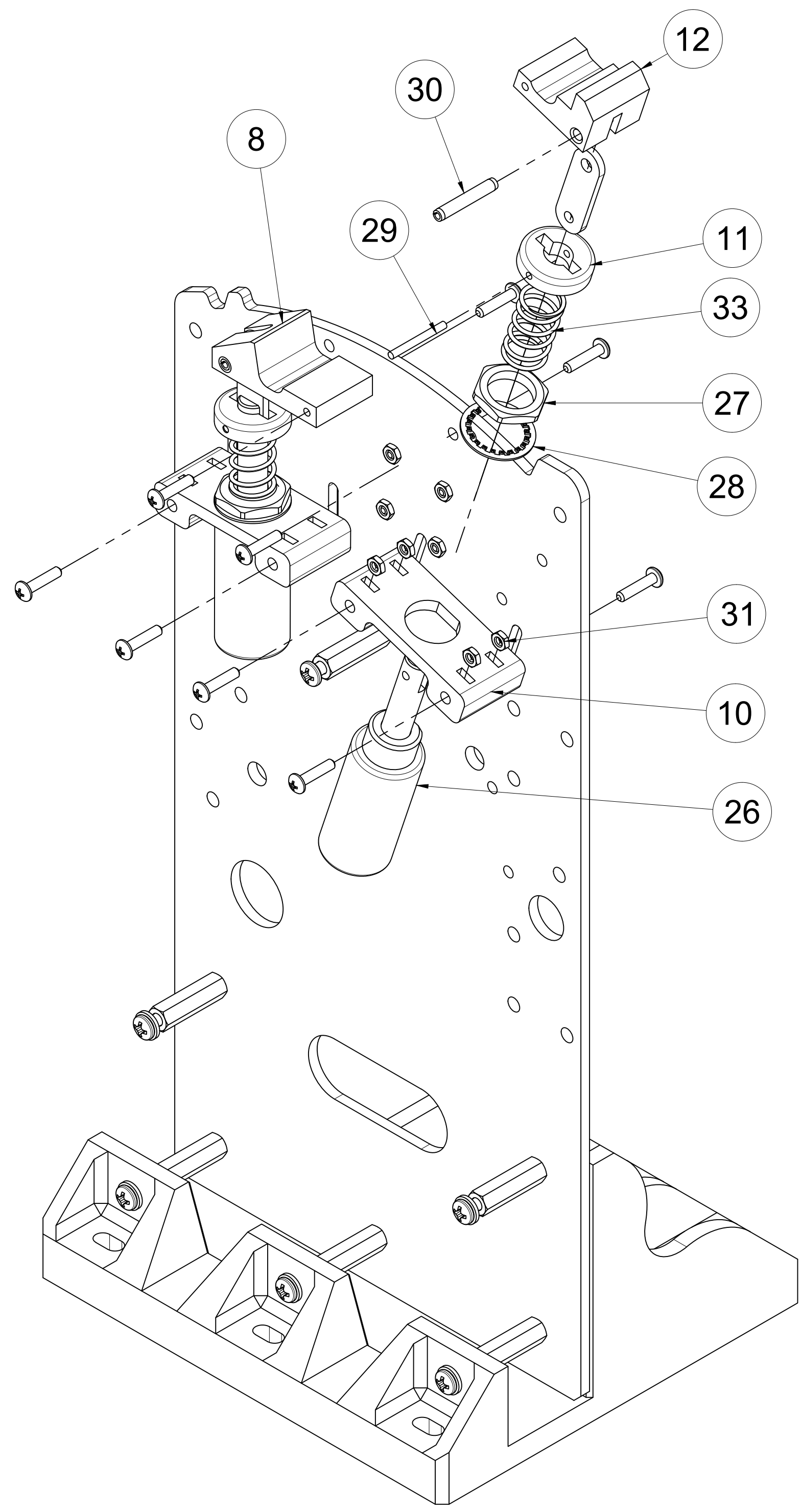

-1 ASSY
DETENT INSTALLATION
(FN 2 HIDDEN FOR CLARITY)

8

7

6

5

4

3

2

1

D

C

B

A

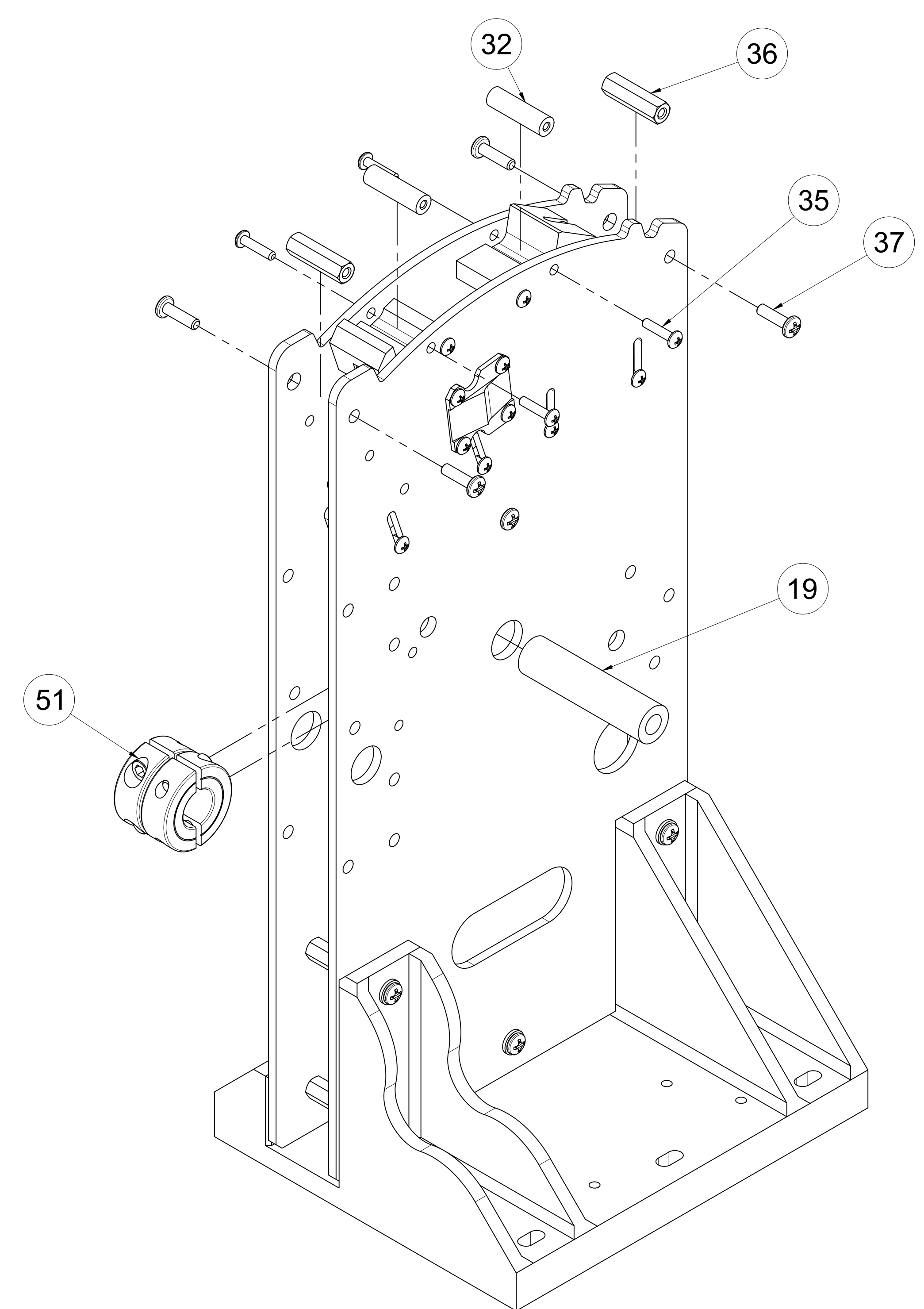

-1 ASSY
MAIN AXLE &
DETENT STOP
INSTALLATION



 OPEN HORNET https://www.OpenHornet.com		SIZE	DWG NO	REV
		D	OH4A9-1	-
SCALE 1:1		SHEET 3/15		

8

7

6

5

4

3

2

1

D

D

C

C

B

B

A

A

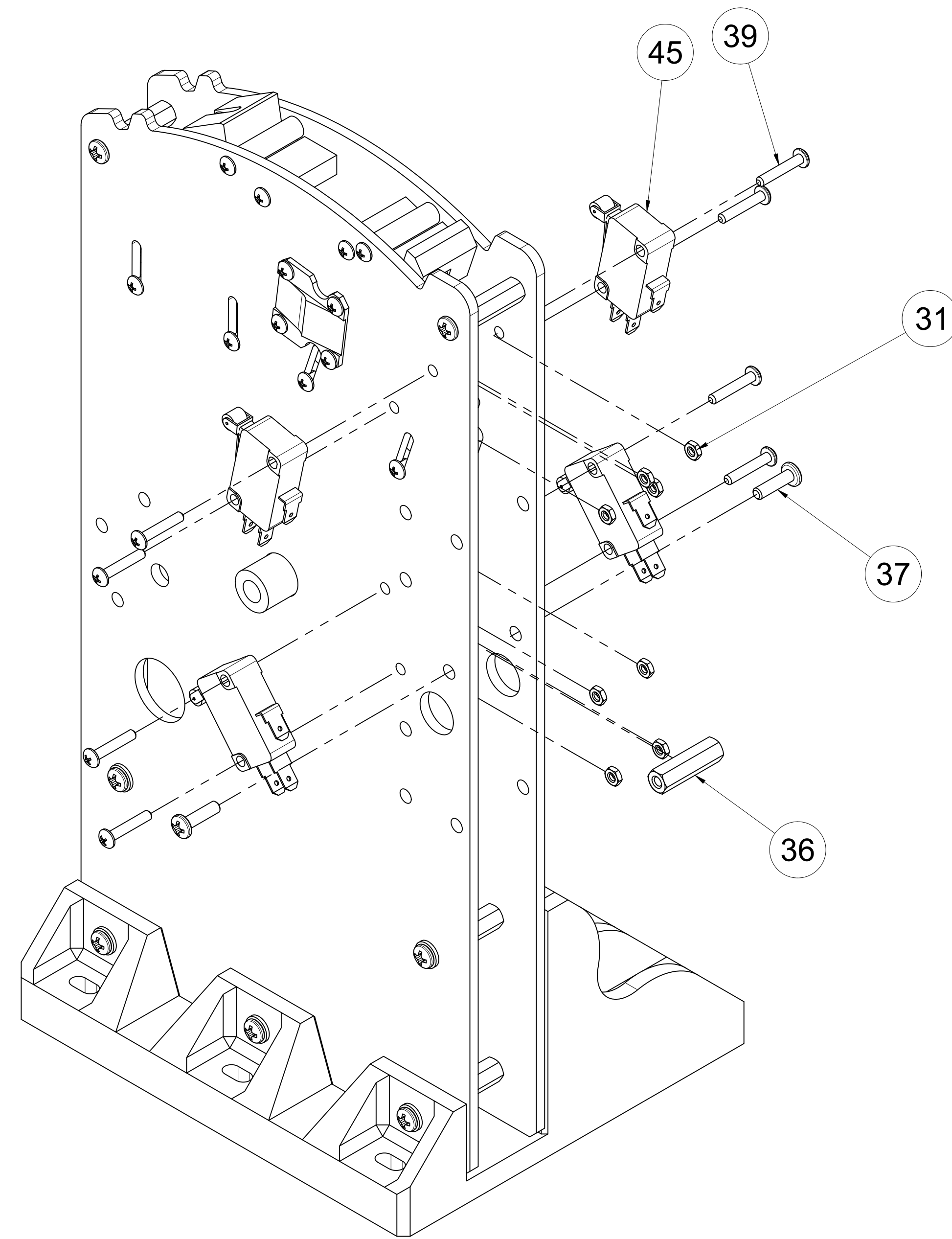

-1 ASSY
OFF/MAX LIMIT
SWITCH
INSTALLATION

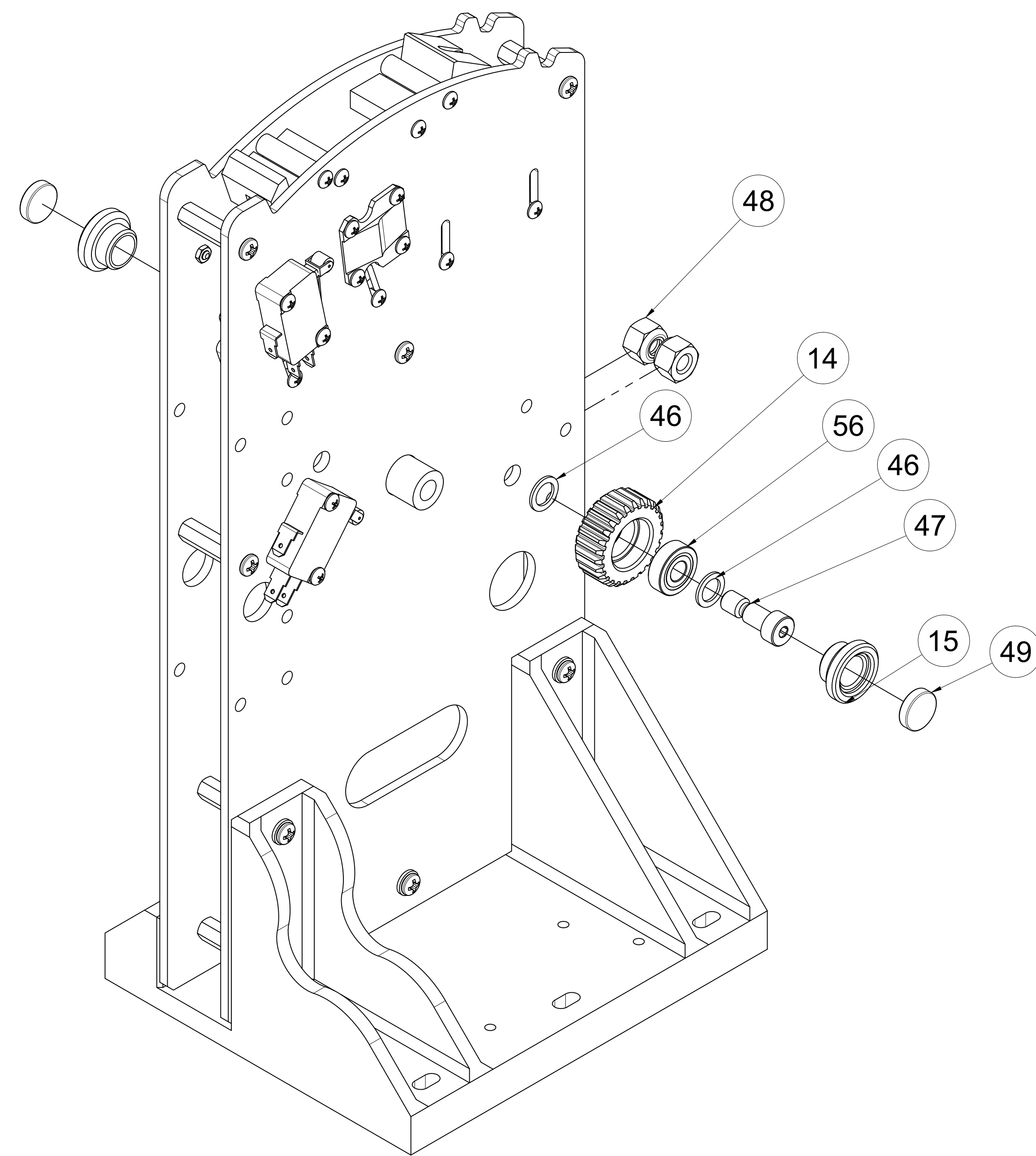

-1 ASSY
MAGNET CUP AND
POSITION GEAR
INSTALLATION



SIZE	DWG NO	REV
D	OH4A9-1	-
SCALE 1:1	SHEET 4/15	

8

7

6

5

4

3

2

1

8

7

6

5

4

3

2

1

D

D

C

C

B

B

A

A

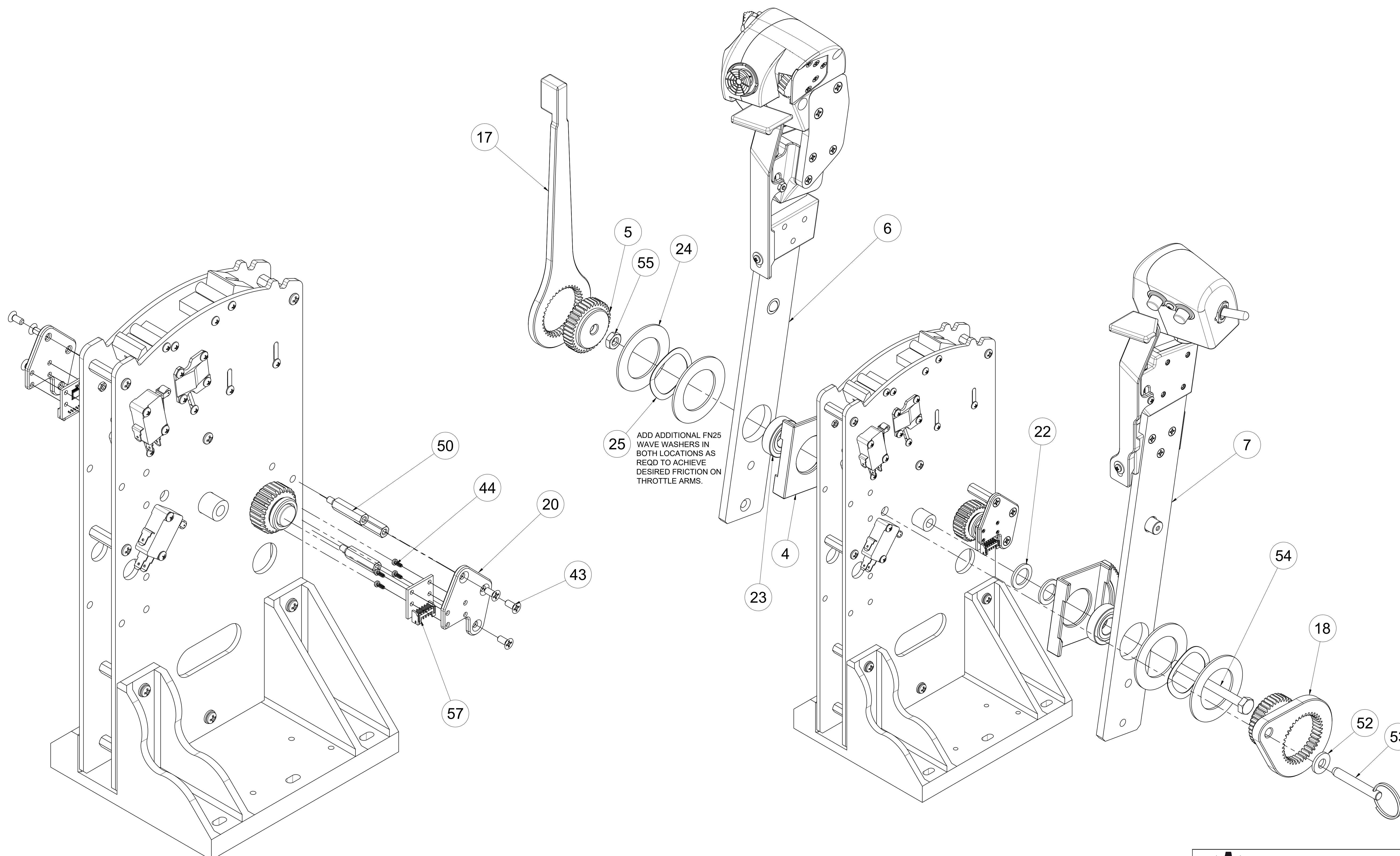

-1 ASSY
HALL SENSOR
INSTALLATION

-1 ASSY
MAIN AXES
ASSEMBLY



SIZE	D	DWG NO	OH4A9-1	REV	-
SCALE	1:1	SHEET 5/15			

8

7

6

5

4

3

2

1



SIZE	DWG NO	REV
D	OH4A9-29	-
SCALE 4:1		SHEET 6/15

8

7

6

5

4

3

2

1

D

D

C

C

B

B

A

A

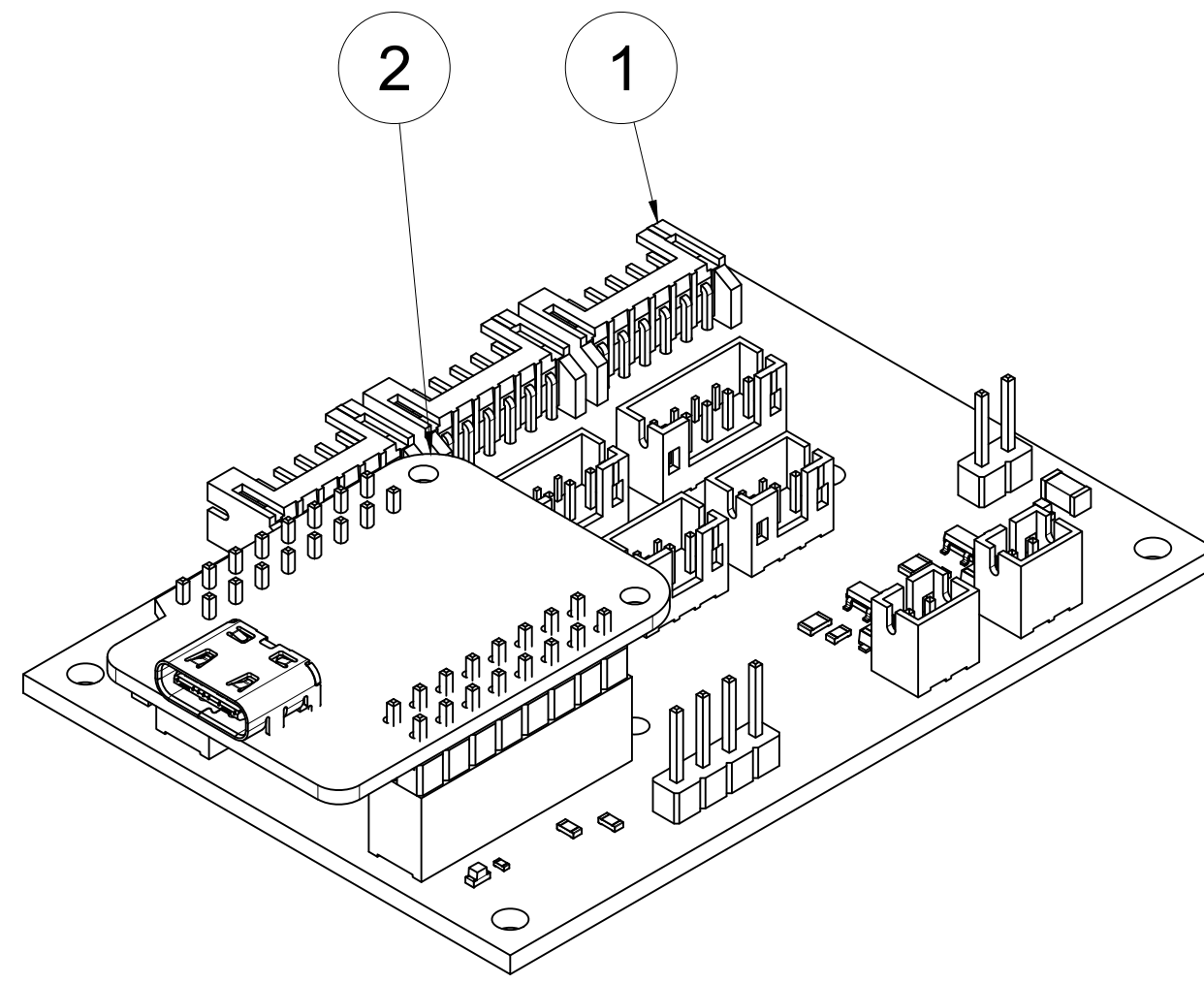

2	1	S2 MINI	MCR, WEMOS S2 MINI, ESP32-S2	
1	1	OH4A9-301	PCB, CONTROLLER, THROTTLE	N/A
ITEM	QTY	PART NUMBER	DESCRIPTION	MATERIAL

PARTS LIST



OPEN HORNET
<https://www.OpenHornet.com>

SIZE	DWG NO	REV
D	OH4A9-300	-

SCALE 2:1 SHEET 7/15

8

7

6

5

4

3

2

1

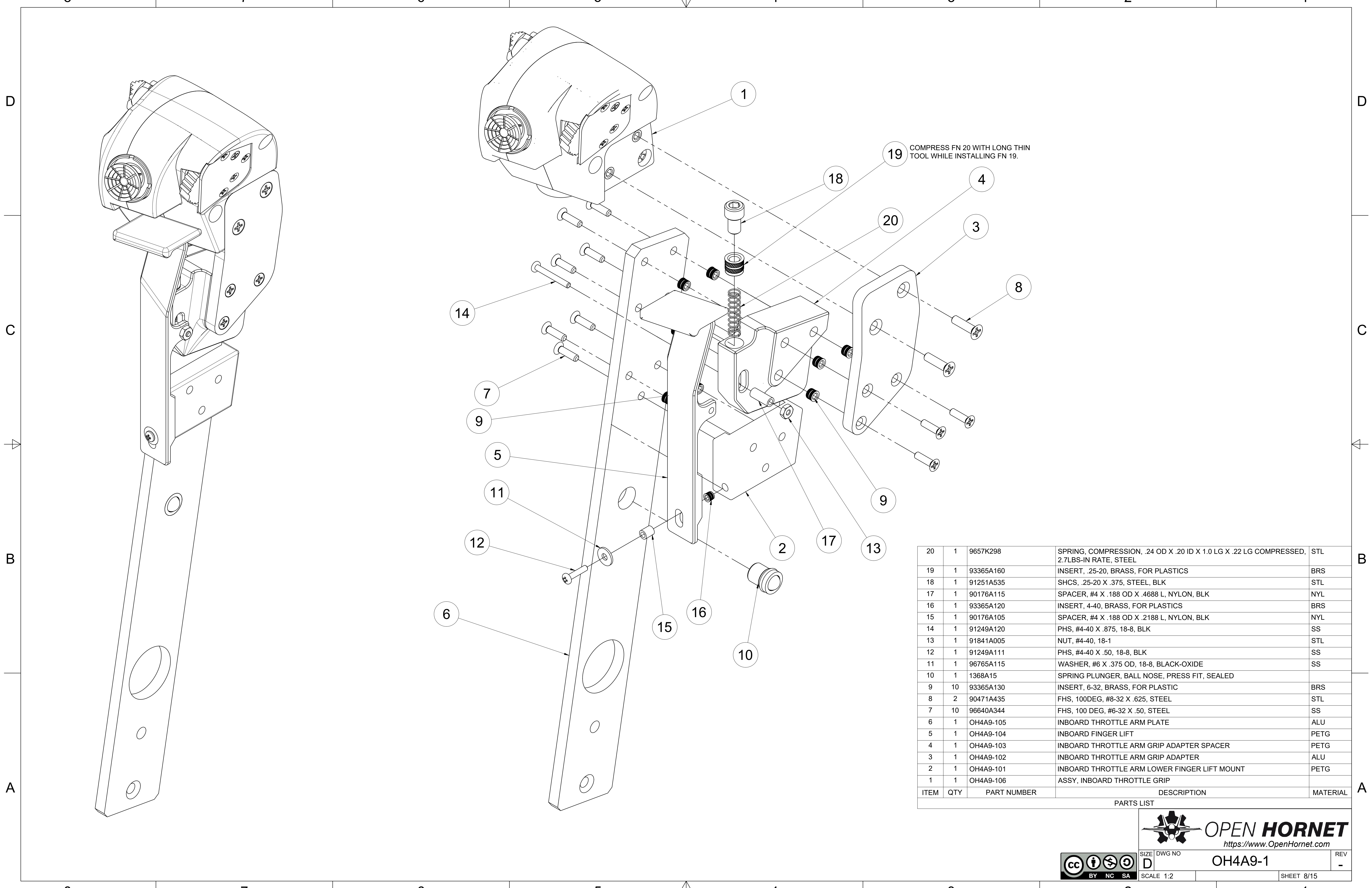

19 COMPRESS FN 20 WITH LONG THIN TOOL WHILE INSTALLING FN 19.

ITEM	QTY	PART NUMBER	DESCRIPTION	MATERIAL
20	1	9657K298	SPRING, COMPRESSION, .24 OD X .20 ID X 1.0 LG X .22 LG COMPRESSED, 2.7LBS-IN RATE, STEEL	STL
19	1	93365A160	INSERT, .25-20, BRASS, FOR PLASTICS	BRS
18	1	91251A535	SHCS, .25-20 X .375, STEEL, BLK	STL
17	1	90176A115	SPACER, #4 X .188 OD X .4688 L, NYLON, BLK	NYL
16	1	93365A120	INSERT, 4-40, BRASS, FOR PLASTICS	BRS
15	1	90176A105	SPACER, #4 X .188 OD X .2188 L, NYLON, BLK	NYL
14	1	91249A120	PHS, #4-40 X .875, 18-8, BLK	SS
13	1	91841A005	NUT, #4-40, 18-1	STL
12	1	91249A111	PHS, #4-40 X .50, 18-8, BLK	SS
11	1	96765A115	WASHER, #6 X .375 OD, 18-8, BLACK-OXIDE	SS
10	1	1368A15	SPRING PLUNGER, BALL NOSE, PRESS FIT, SEALED	
9	10	93365A130	INSERT, 6-32, BRASS, FOR PLASTIC	BRS
8	2	90471A435	FHS, 100DEG, #8-32 X .625, STEEL	STL
7	10	96640A344	FHS, 100 DEG, #6-32 X .50, STEEL	SS
6	1	OH4A9-105	INBOARD THROTTLE ARM PLATE	ALU
5	1	OH4A9-104	INBOARD FINGER LIFT	PETG
4	1	OH4A9-103	INBOARD THROTTLE ARM GRIP ADAPTER SPACER	PETG
3	1	OH4A9-102	INBOARD THROTTLE ARM GRIP ADAPTER	ALU
2	1	OH4A9-101	INBOARD THROTTLE ARM LOWER FINGER LIFT MOUNT	PETG
1	1	OH4A9-106	ASSY, INBOARD THROTTLE GRIP	

PARTS LIST



SIZE: D DWG NO: OH4A9-1 REV: -
 SCALE: 1:2 SHEET: 8/15

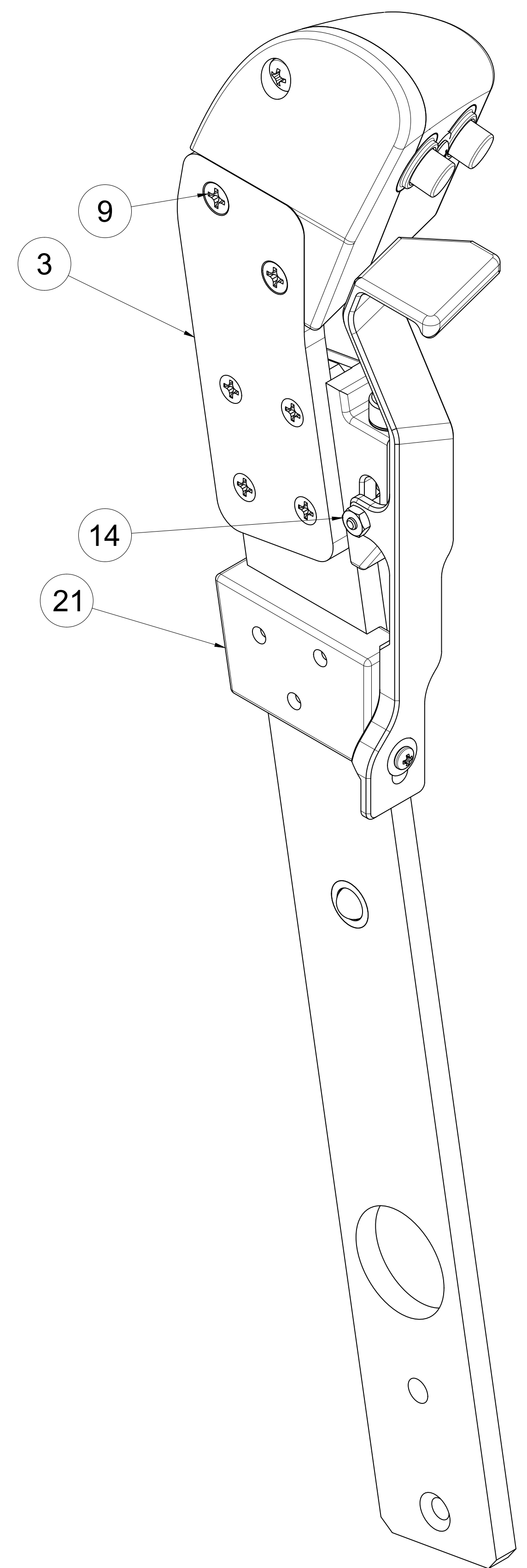
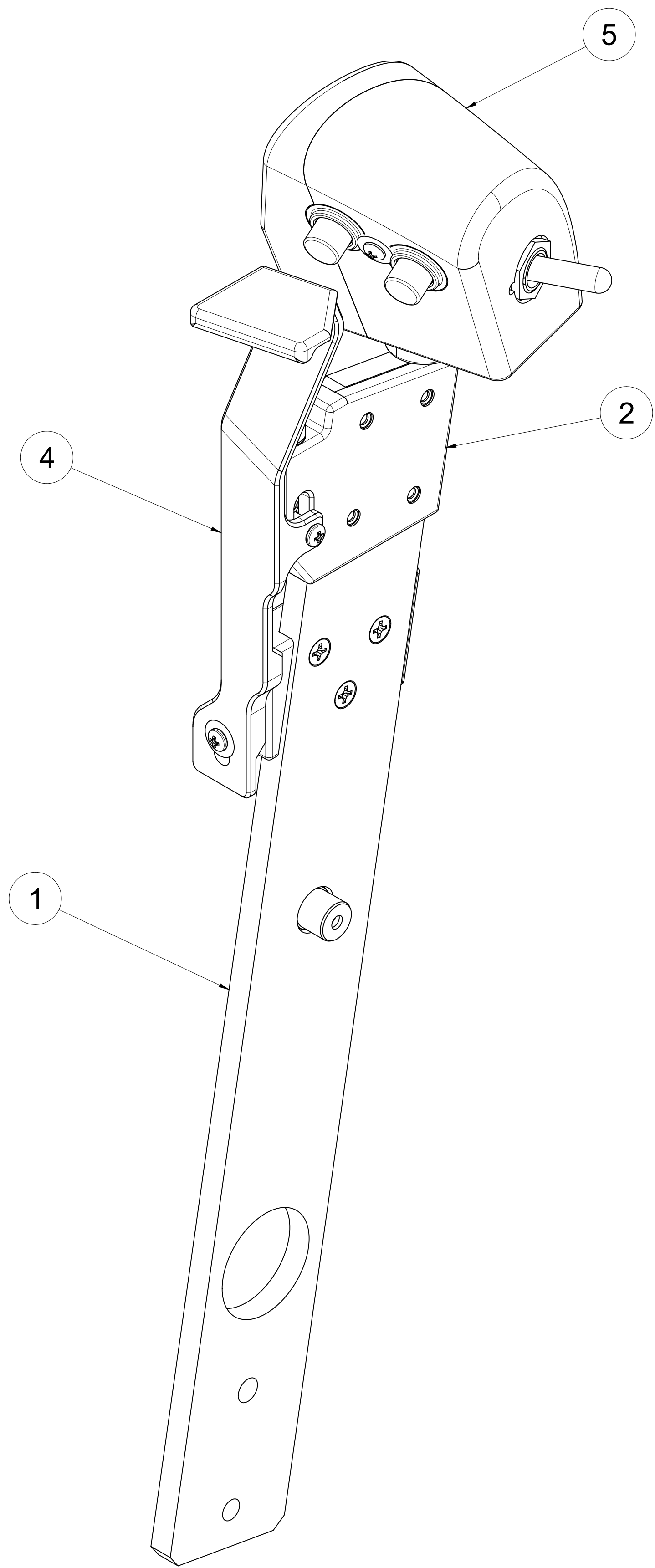

-200 ASSEMBLY IS
SAME AS -100, EXCEPT
AS NOTED.

ITEM	QTY	PART NUMBER	DESCRIPTION	MATERIAL
21	1	OH4A9-208	OUTBOARD THROTTLE ARM LOWER FINGERLIFT ADAPTER	PETG
20	1	9657K298	SPRING, COMPRESSION, .24 OD X .20 ID X 1.0 LG X .22 LG COMPRESSED, 2.7LBS-IN RATE, STEEL	STL
19	1	93365A160	INSERT, .25-20, BRASS, FOR PLASTICS	BRS
18	1	91251A535	SHCS, .25-20 X .375, STEEL, BLK	STL
17	1	90176A115	SPACER, #4 X .188 OD X .4688 L, NYLON, BLK	NYL
16	1	90176A105	SPACER, #4 X .188 OD X .2188 L, NYLON, BLK	NYL
15	1	93365A120	INSERT, 4-40, BRASS, FOR PLASTICS	BRS
14	1	91841A005	NUT, #4-40, 18-1	STL
13	1	91249A120	PHS, #4-40 X .875, 18-8, BLK	SS
12	1	96765A115	WASHER, #6 X .375 OD, 18-8, BLACK-OXIDE	SS
11	1	91249A111	PHS, #4-40 X .50, 18-8, BLK	SS
10	7	93365A130	INSERT, 6-32, BRASS, FOR PLASTIC	BRS
9	2	90471A435	FHS, 100DEG, #8-32 X .625, STEEL	STL
8	4	93085A628	FHS, 100DEG, #6-32 X .625, 18-8, BLK	SS
7	3	96640A344	FHS, 100 DEG, #6-32 X .50, STEEL	SS
6	1	1368A15	SPRING PLUNGER, BALL NOSE, PRESS FIT, SEALED	
5	1	OH4A9-205	ASSY, OUTBOARD THROTTLE GRIP	
4	1	OH4A9-204	OUTBOARD FINGER LIFT	PETG
3	1	OH4A9-203	OUTBOARD THROTTLE ARM GRIP ADAPTER	ALU
2	1	OH4A9-202	OUTBOARD THROTTLE ARM GRIP ADAPTER SPACER	PETG
1	1	OH4A9-201	OUTBOARD THROTTLE ARM PLATE	ALU



SIZE DWG NO REV
D OH4A9-1 -
SCALE 1:2 SHEET 9/15

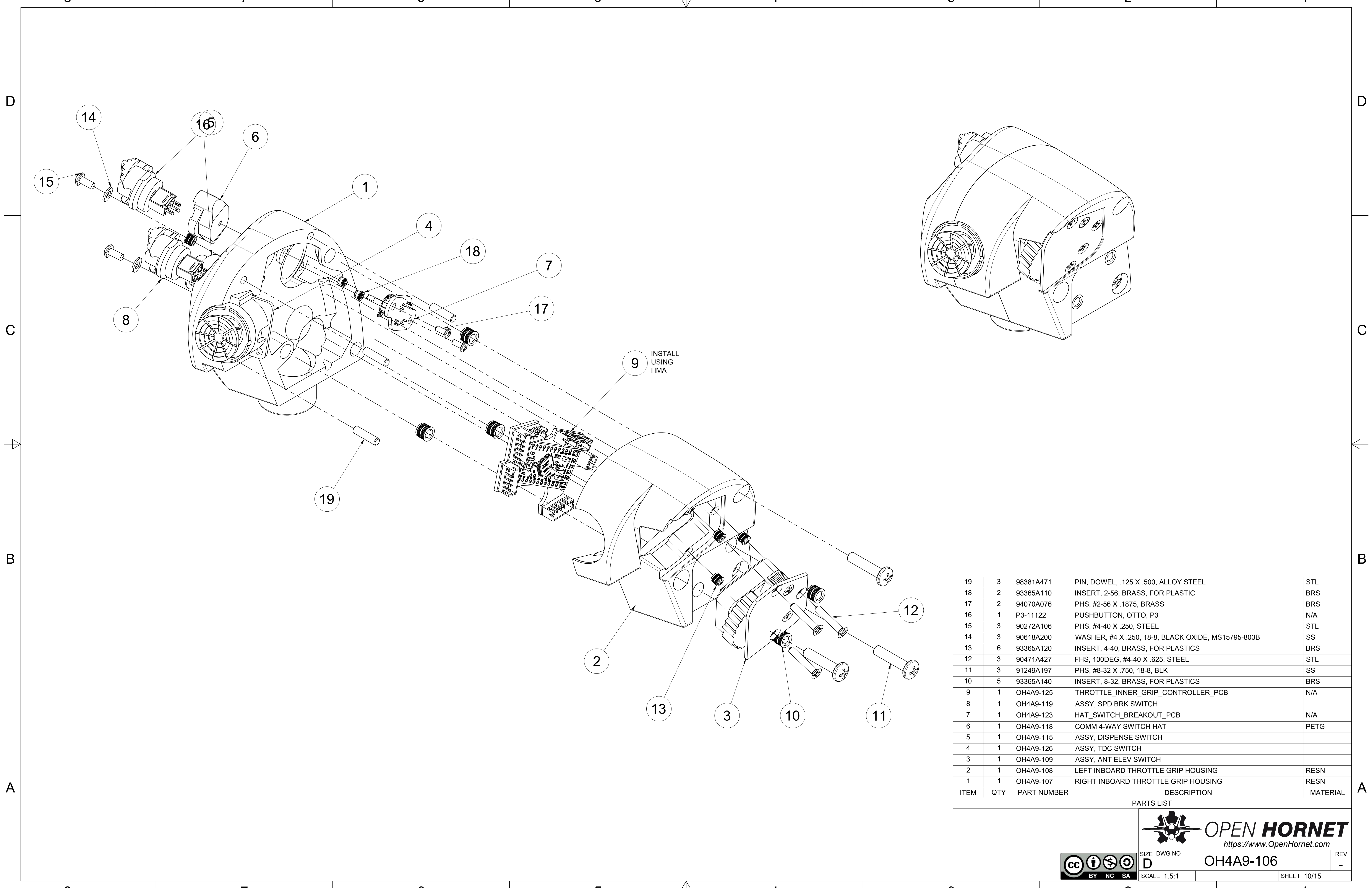

ITEM	QTY	PART NUMBER	DESCRIPTION	MATERIAL
19	3	98381A471	PIN, DOWEL, .125 X .500, ALLOY STEEL	STL
18	2	93365A110	INSERT, 2-56, BRASS, FOR PLASTIC	BRS
17	2	94070A076	PHS, #2-56 X .1875, BRASS	BRS
16	1	P3-11122	PUSHBUTTON, OTTO, P3	N/A
15	3	90272A106	PHS, #4-40 X .250, STEEL	STL
14	3	90618A200	WASHER, #4 X .250, 18-8, BLACK OXIDE, MS15795-803B	SS
13	6	93365A120	INSERT, 4-40, BRASS, FOR PLASTICS	BRS
12	3	90471A427	FHS, 100DEG, #4-40 X .625, STEEL	STL
11	3	91249A197	PHS, #8-32 X .750, 18-8, BLK	SS
10	5	93365A140	INSERT, 8-32, BRASS, FOR PLASTICS	BRS
9	1	OH4A9-125	THROTTLE_INNER_GRIP_CONTROLLER_PCB	N/A
8	1	OH4A9-119	ASSY, SPD BRK SWITCH	
7	1	OH4A9-123	HAT_SWITCH_BREAKOUT_PCB	N/A
6	1	OH4A9-118	COMM 4-WAY SWITCH HAT	PETG
5	1	OH4A9-115	ASSY, DISPENSE SWITCH	
4	1	OH4A9-126	ASSY, TDC SWITCH	
3	1	OH4A9-109	ASSY, ANT ELEV SWITCH	
2	1	OH4A9-108	LEFT INBOARD THROTTLE GRIP HOUSING	RESN
1	1	OH4A9-107	RIGHT INBOARD THROTTLE GRIP HOUSING	RESN



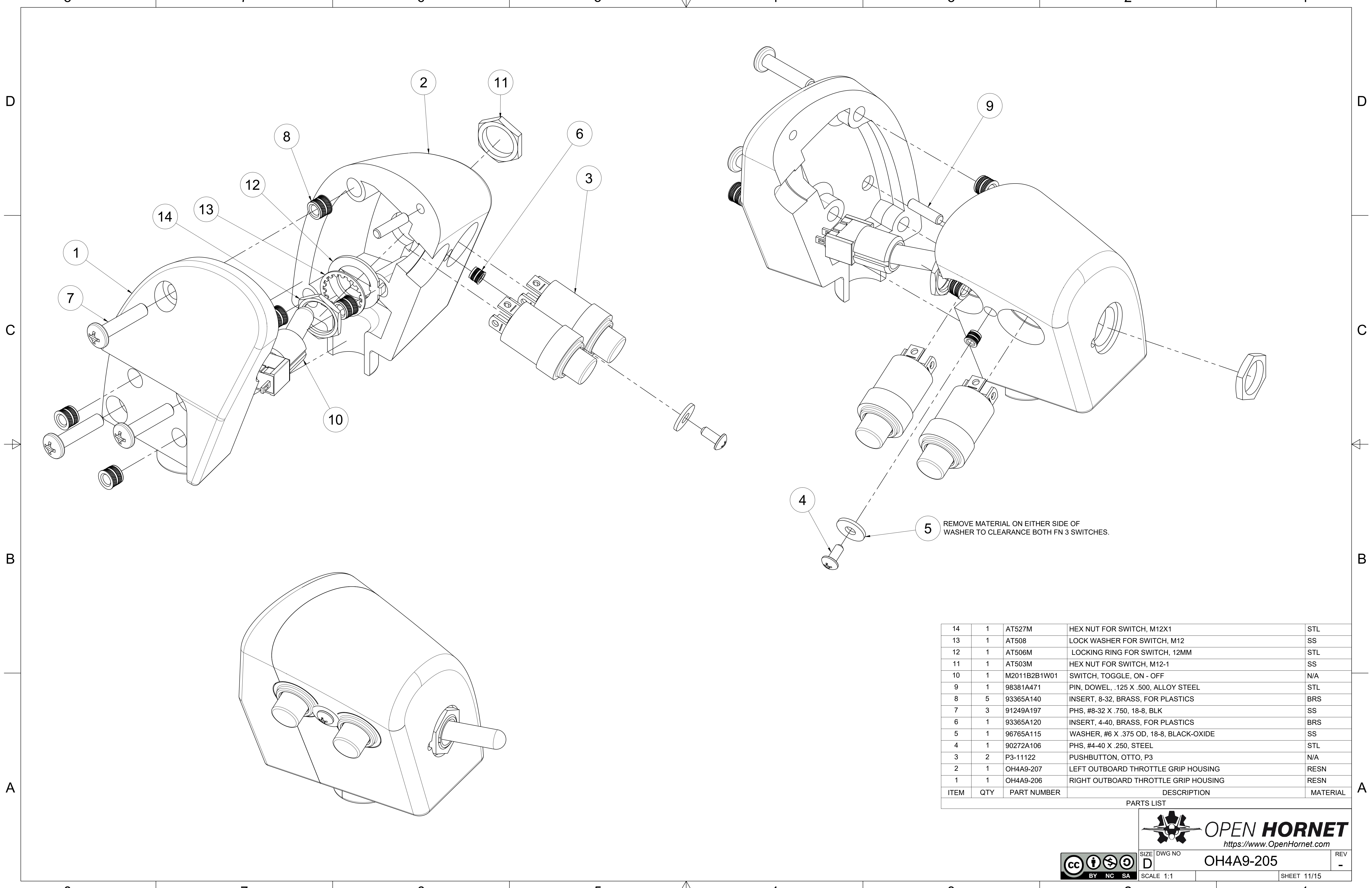

ITEM	QTY	PART NUMBER	DESCRIPTION	MATERIAL
14	1	AT527M	HEX NUT FOR SWITCH, M12X1	STL
13	1	AT508	LOCK WASHER FOR SWITCH, M12	SS
12	1	AT506M	LOCKING RING FOR SWITCH, 12MM	STL
11	1	AT503M	HEX NUT FOR SWITCH, M12-1	SS
10	1	M2011B2B1W01	SWITCH, TOGGLE, ON - OFF	N/A
9	1	98381A471	PIN, DOWEL, .125 X .500, ALLOY STEEL	STL
8	5	93365A140	INSERT, 8-32, BRASS, FOR PLASTICS	BRS
7	3	91249A197	PHS, #8-32 X .750, 18-8, BLK	SS
6	1	93365A120	INSERT, 4-40, BRASS, FOR PLASTICS	BRS
5	1	96765A115	WASHER, #6 X .375 OD, 18-8, BLACK-OXIDE	SS
4	1	90272A106	PHS, #4-40 X .250, STEEL	STL
3	2	P3-11122	PUSHBUTTON, OTTO, P3	N/A
2	1	OH4A9-207	LEFT OUTBOARD THROTTLE GRIP HOUSING	RESN
1	1	OH4A9-206	RIGHT OUTBOARD THROTTLE GRIP HOUSING	RESN



SIZE D DWG NO OH4A9-205 REV -
 SCALE 1:1 SHEET 11/15

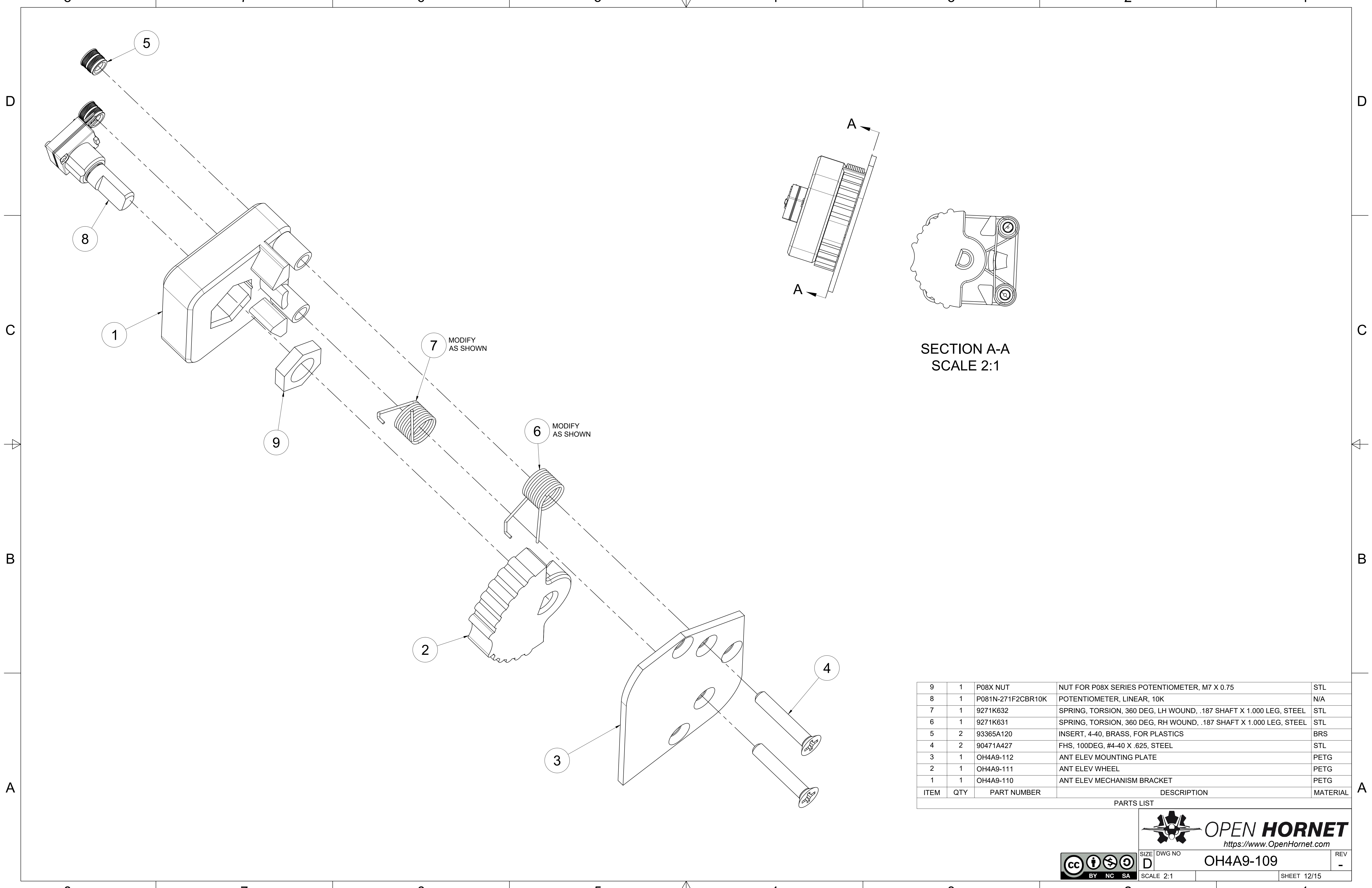

SECTION A-A
SCALE 2:1

ITEM	QTY	PART NUMBER	DESCRIPTION	MATERIAL
9	1	P08X NUT	NUT FOR P08X SERIES POTENTIOMETER, M7 X 0.75	STL
8	1	P081N-271F2CBR10K	POTENTIOMETER, LINEAR, 10K	N/A
7	1	9271K632	SPRING, TORSION, 360 DEG, LH WOUND, .187 SHAFT X 1.000 LEG, STEEL	STL
6	1	9271K631	SPRING, TORSION, 360 DEG, RH WOUND, .187 SHAFT X 1.000 LEG, STEEL	STL
5	2	93365A120	INSERT, 4-40, BRASS, FOR PLASTICS	BRS
4	2	90471A427	FHS, 100DEG, #4-40 X .625, STEEL	STL
3	1	OH4A9-112	ANT ELEV MOUNTING PLATE	PETG
2	1	OH4A9-111	ANT ELEV WHEEL	PETG
1	1	OH4A9-110	ANT ELEV MECHANISM BRACKET	PETG



SIZE	DWG NO	REV
D	OH4A9-109	-
SCALE 2:1		SHEET 12/15

8

7

6

5

4

3

2

1

D

D

C

C

B

B

A

A

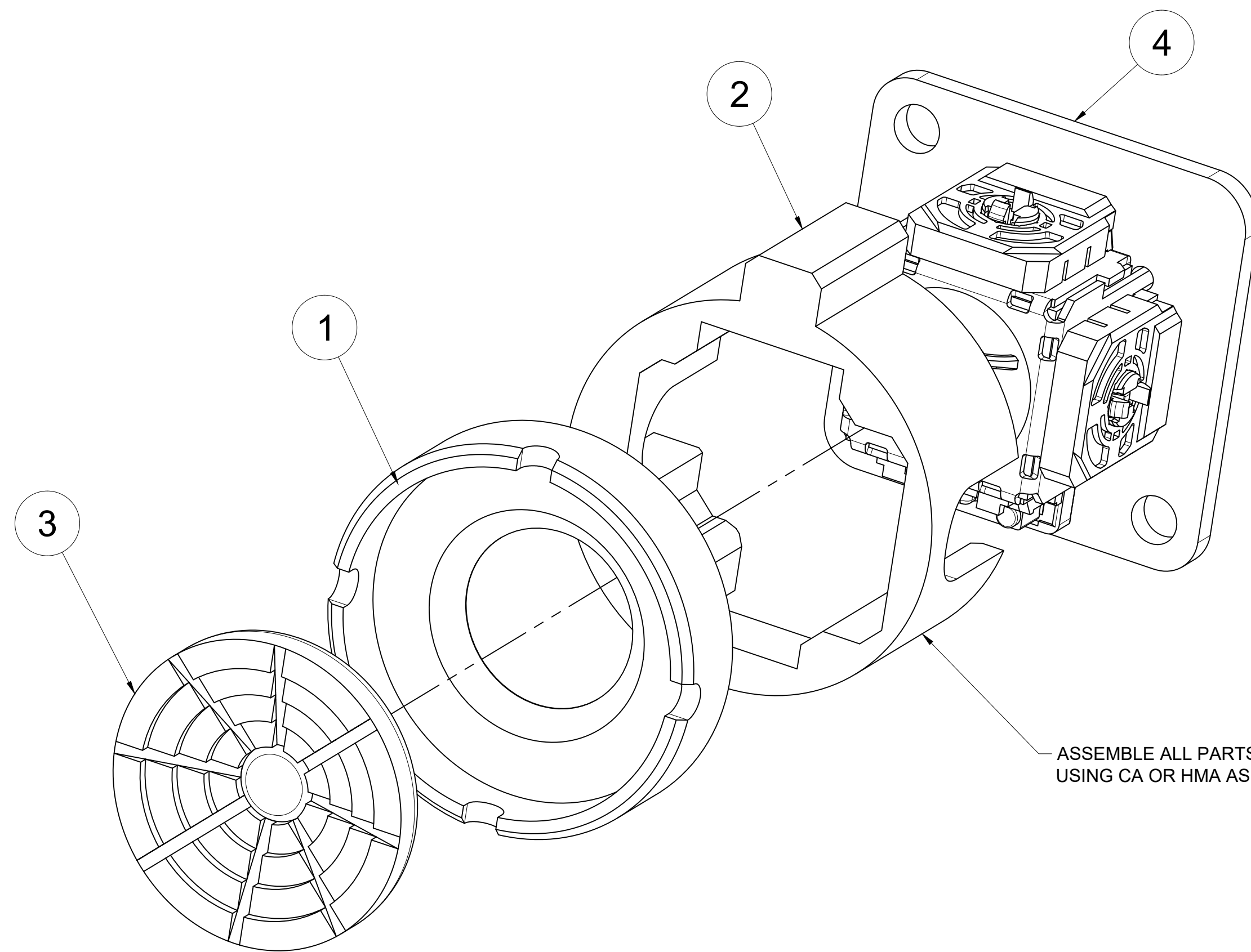
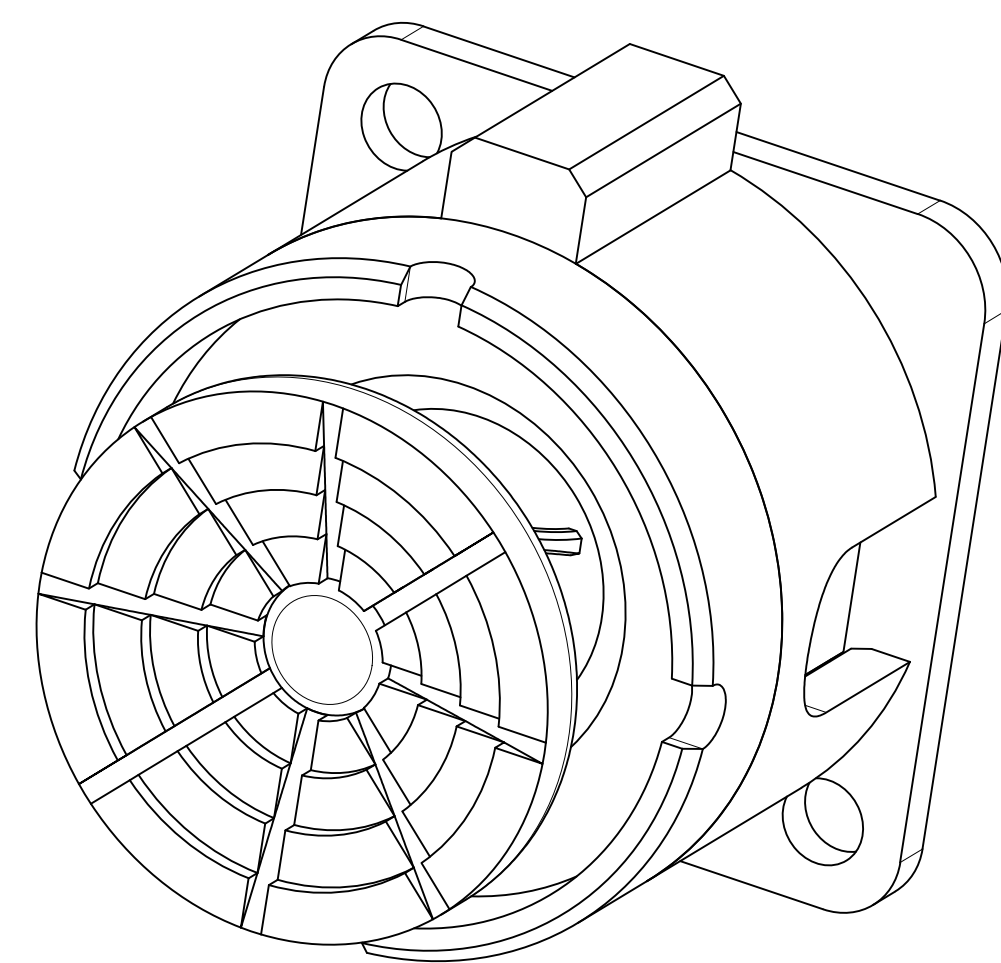

ASSEMBLE ALL PARTS
USING CA OR HMA AS REQD.

ITEM	QTY	PART NUMBER	DESCRIPTION	MATERIAL
4	1	OH4A9-121	ANALOG_STICK_BREAKOUT_PCB	N/A
3	1	OH4A9-120	TDC SWITCH CAP	PETG
2	1	OH4A9-114	LOWER TDC SWITCH BODY	PETG
1	1	OH4A9-113	TDC SWITCH BODY	PETG

PARTS LIST



SIZE	D	DWG NO	OH4A9-126	REV	-
SCALE	1:1			SHEET 13/15	

8

7

6

5

4

3

2

1

8

7

6

5

4

3

2

1

D

D

C

C

B

B

A

A

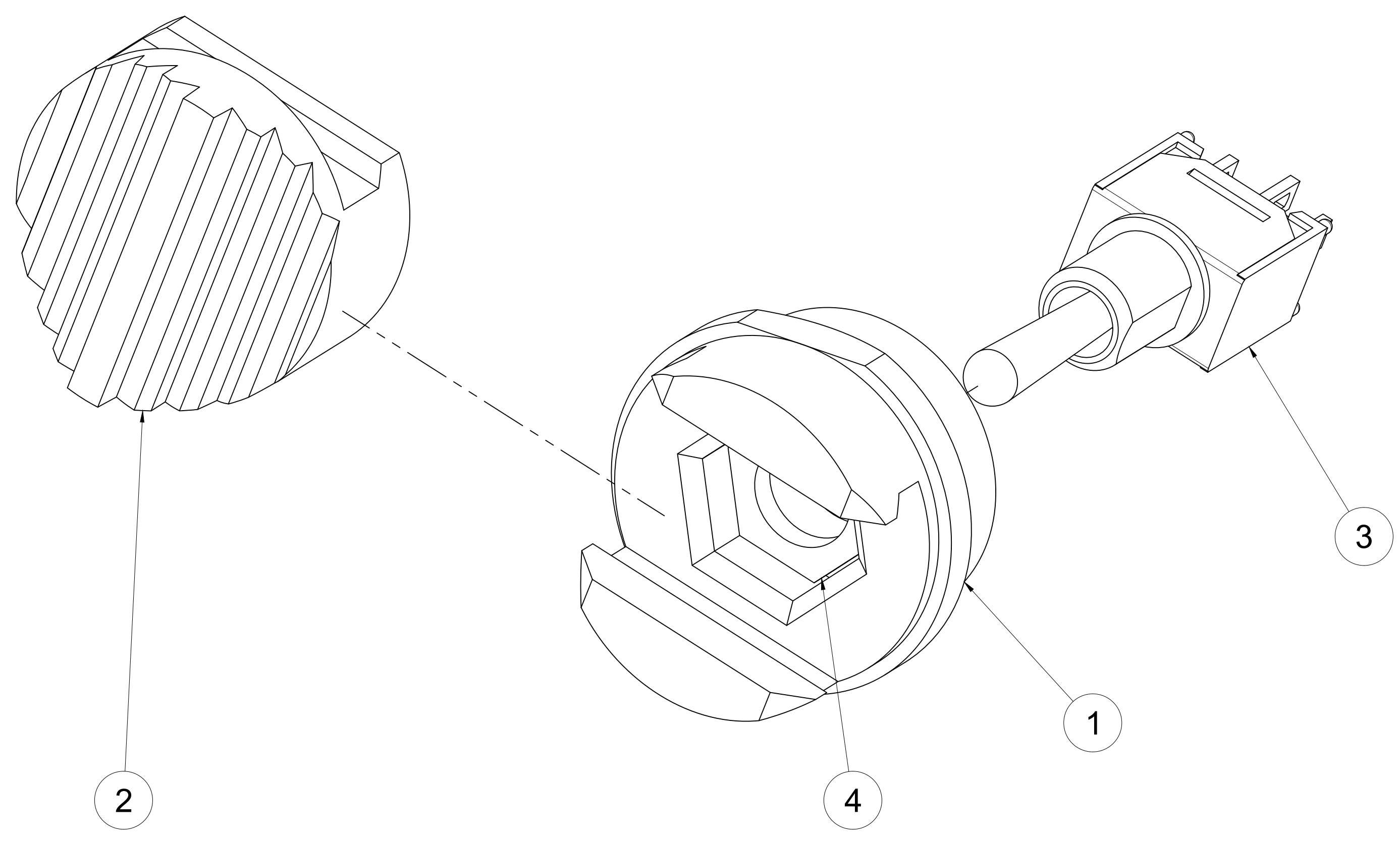

ITEM	QTY	PART NUMBER	DESCRIPTION	MATERIAL
4	1	HDW211048UNSHENUT		N/A
3	1	200MSP4T1B1M1QE	SWITCH, TOGGLE, SUB-MINIATURE, 3-POS, (ON)-OFF-(ON)	N/A
2	1	OH4A9-117	SPD BRK SWITCH CAP	RESN
1	1	OH4A9-122	SPD BRK SWITCH BODY	RESN

PARTS LIST



SIZE	DWG NO	REV
D	OH4A9-115	-

8

7

6

5

4

3

2

1

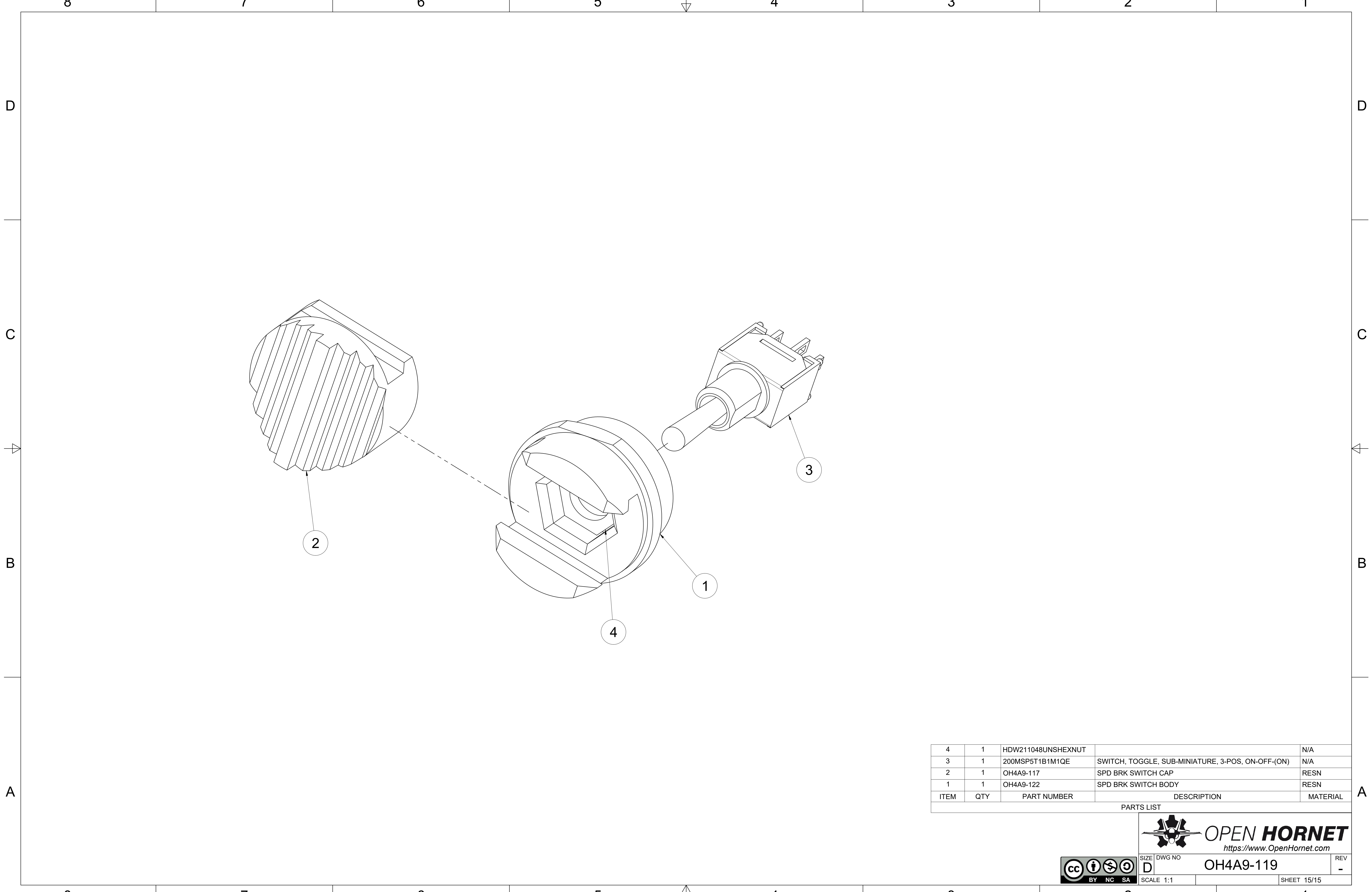

ITEM	QTY	PART NUMBER	DESCRIPTION	MATERIAL
4	1	HDW211048UNSHENUT		N/A
3	1	200MSP5T1B1M1QE	SWITCH, TOGGLE, SUB-MINIATURE, 3-POS, ON-OFF-(ON)	N/A
2	1	OH4A9-117	SPD BRK SWITCH CAP	RESN
1	1	OH4A9-122	SPD BRK SWITCH BODY	RESN



SIZE	D	DWG NO	OH4A9-119	REV	-
SCALE	1:1			SHEET 15/15	