

clean. quiet. powerful.

white on white. a sense of mystery. nothing extraneous. polite, but not meek.

georgia.

lowercase. ampersands. *colored italics*, never bold, never underlined. left aligned. type hierarchy built through size, and also through color: creamy blue, flat black, & white.

images.

energetic. cold. blue, white, black. reflect the movement of water rather than the life inside of it. implicit rather than explicit.

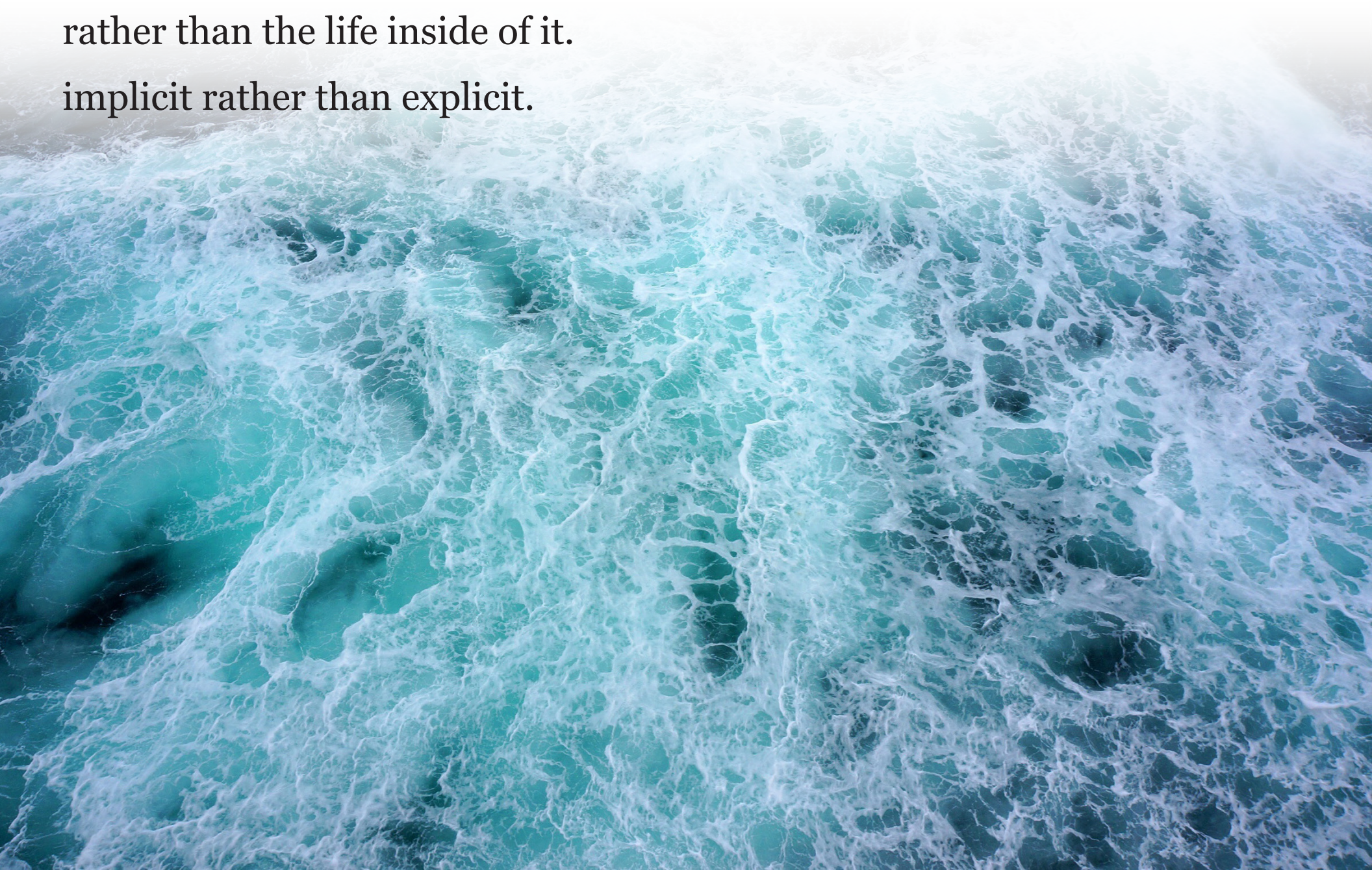

clean. quiet. powerful.

white on white. a sense of mystery. nothing extraneous. polite, but not meek.

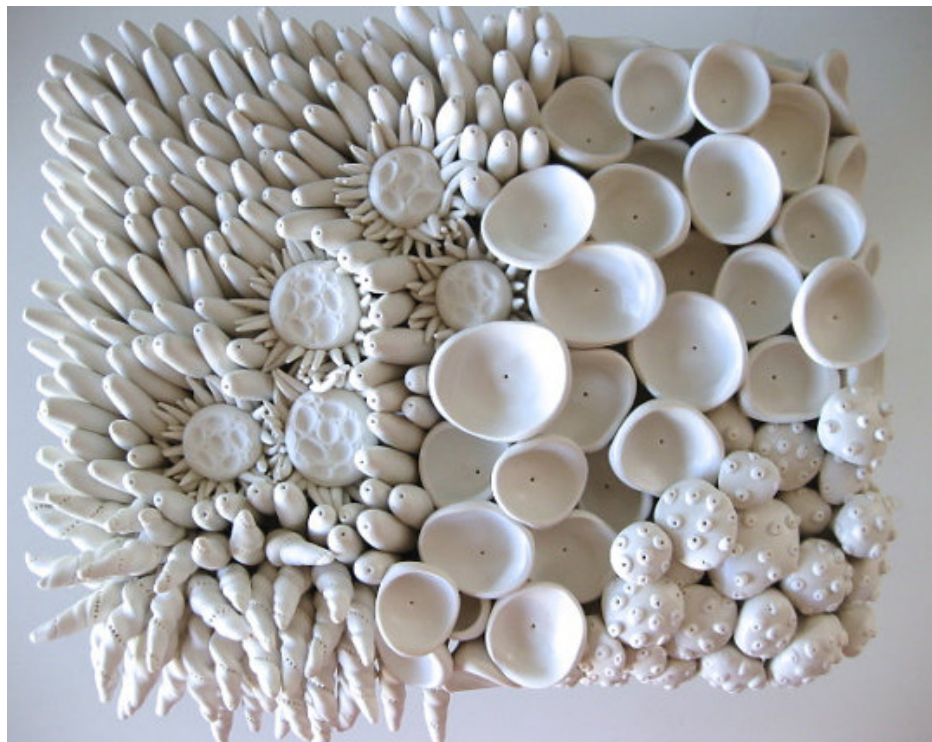
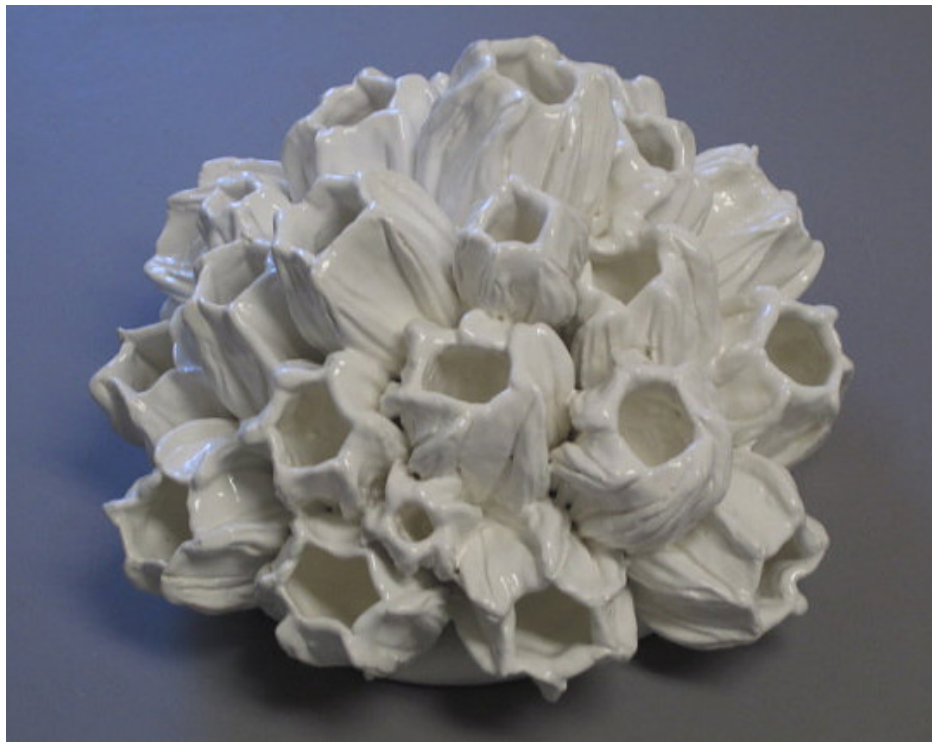

angela schwer



johnson tsang



ruth asawa



bioluminescent plankton

MECHANICAL

Transparency; curiosity; hardware; industrial

Raleway

Clear & easy to read; intersecting lines; **bold**, *italic*, **colored**. Left-aligned, dividing lines, hierarchy built through size and weight. Color scheme in grayscale with **pops of red**.

Images

Technical but friendly, inspiration from diagramming. Educational vibe. Embraces industry and machinery instead of hiding it.

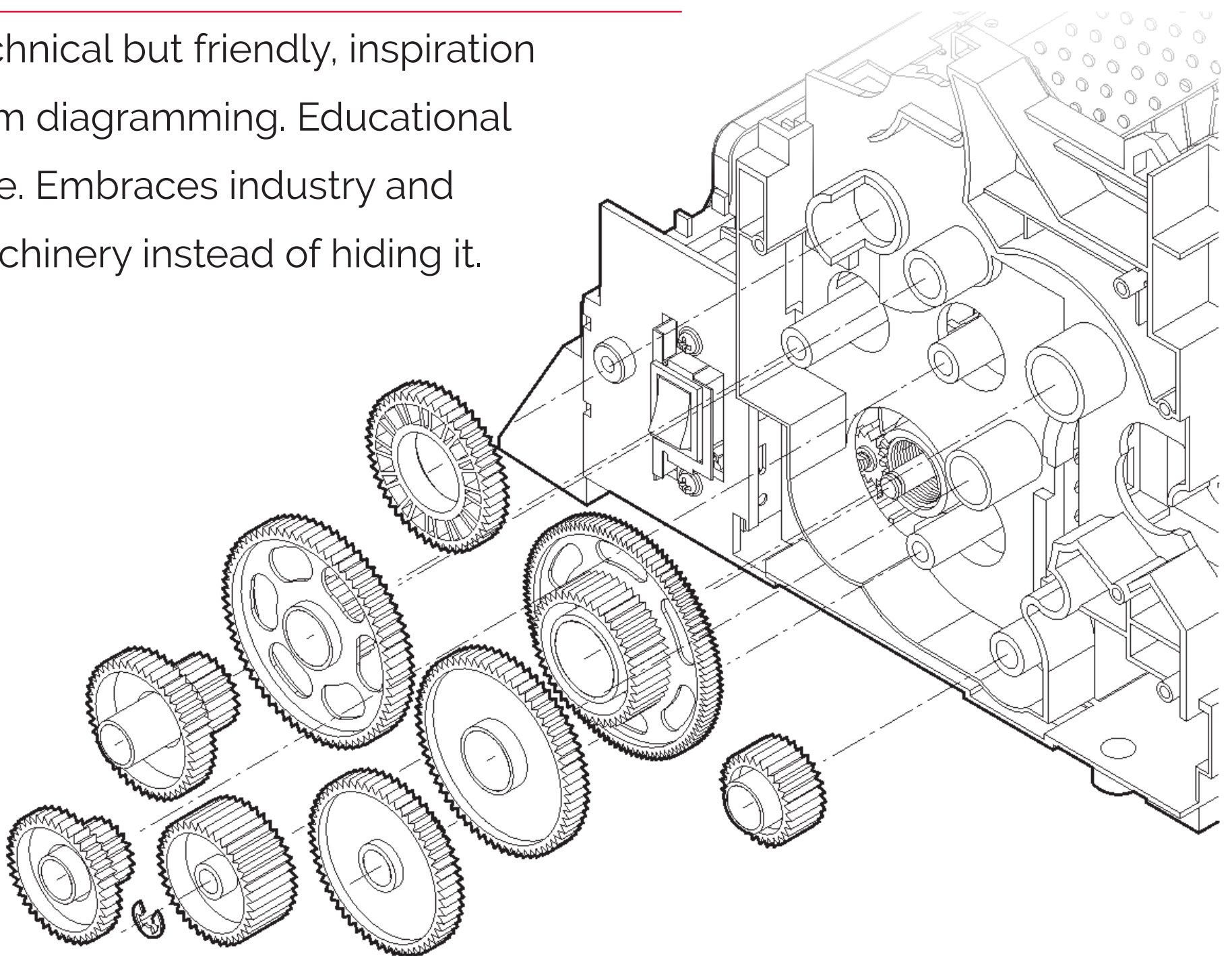

MECHANICAL

Transparency; curiosity; hardware; industrial

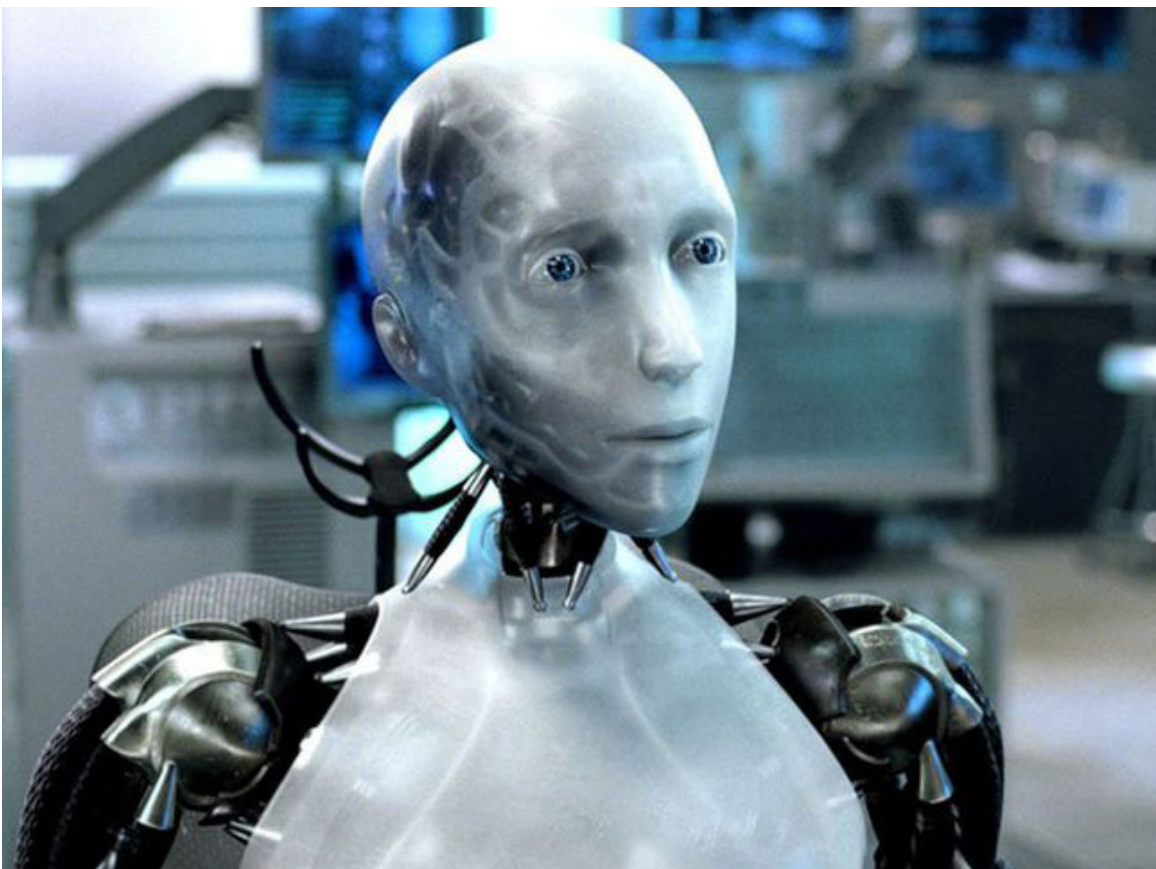
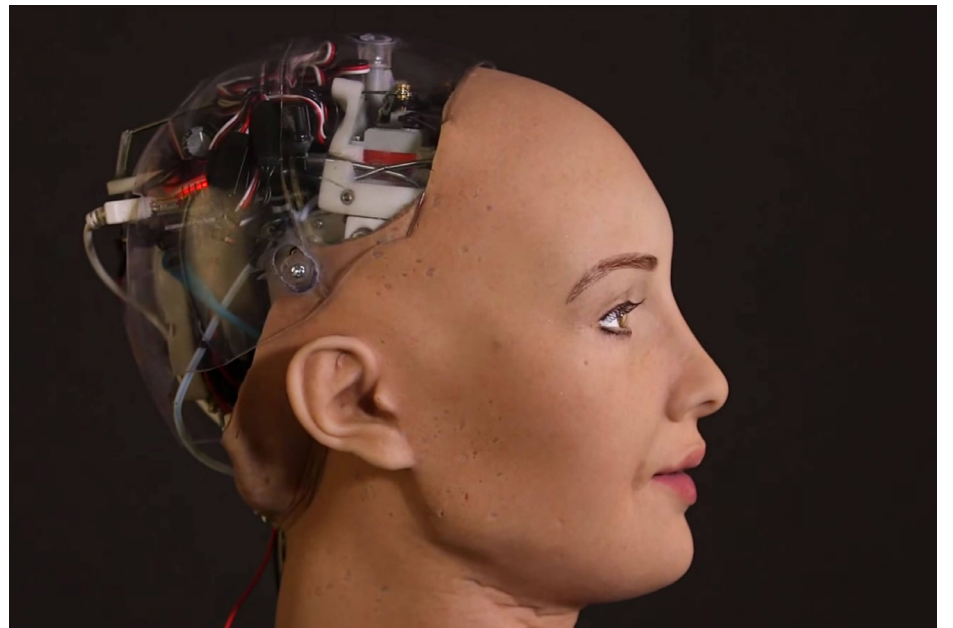
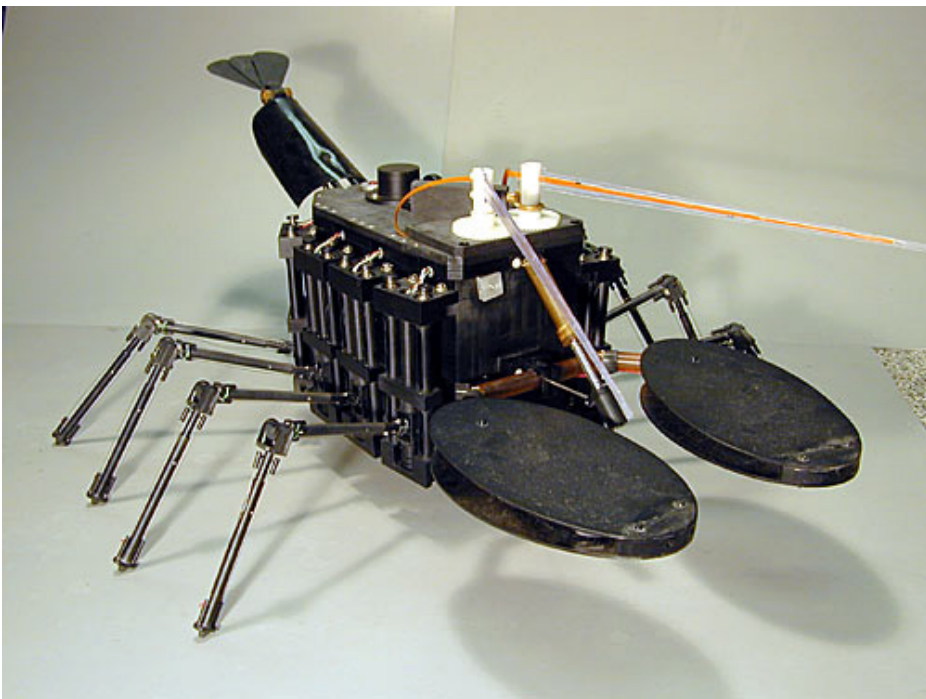
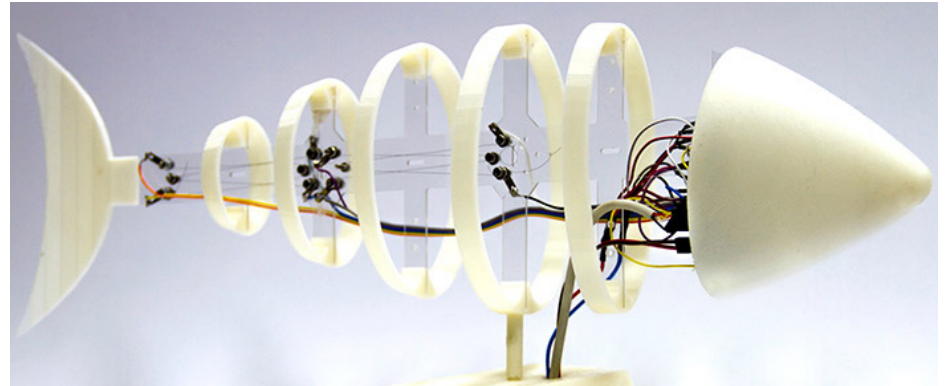
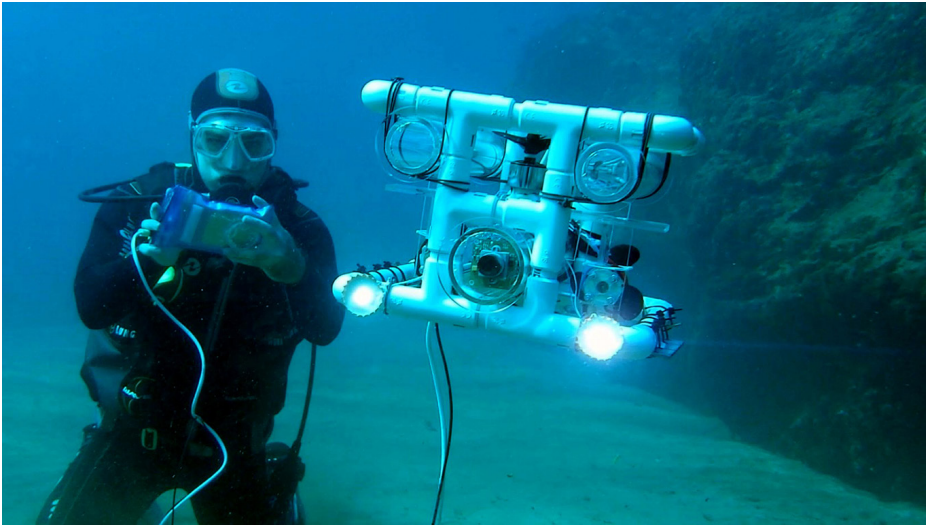

proces/prototypes

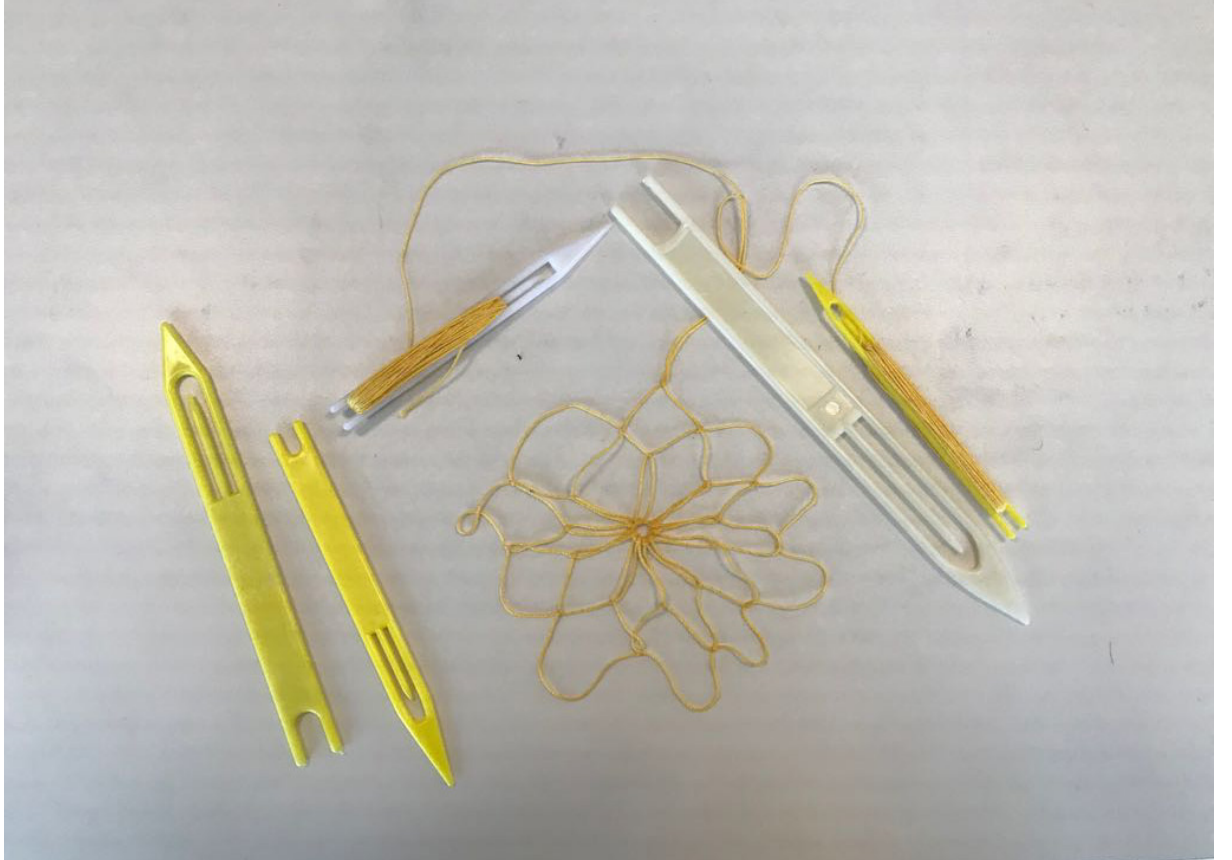
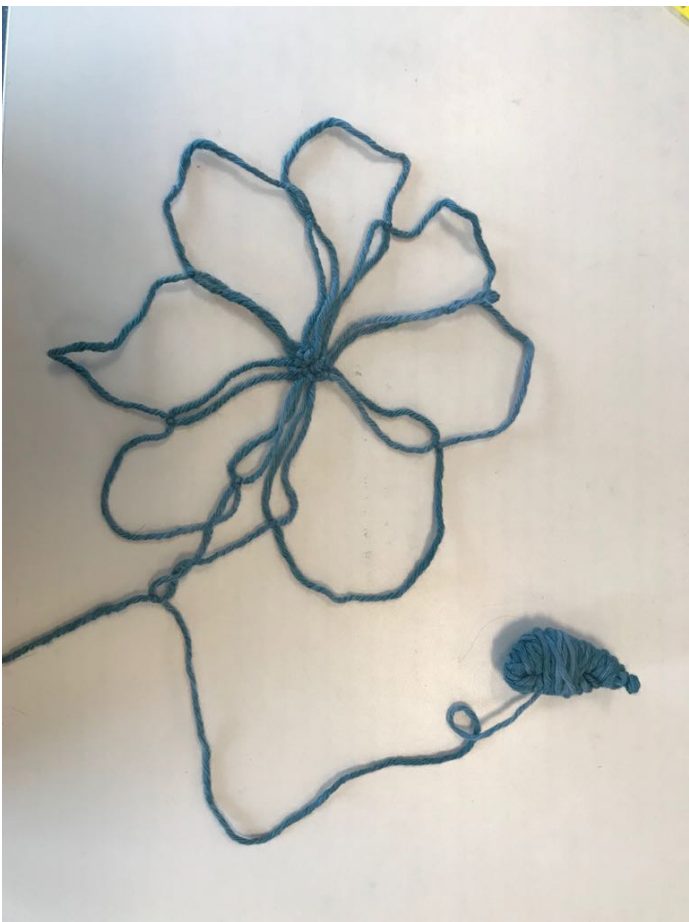

left top: first net, straight

left: first circular net

right top: current WIP for near full scale prototype in cotton; circular; also includes netting shuttles

left bottom: gallery 360 corner (install location)

right bottom: gallery 360 corner ceiling

