

睿智皓天（成都）信息技术有限公司

File Name	Specification For HINK 2.13" EPD	Module Number	LCMEN2R13EFC1
Version	A0	Page Number	1 of 44

Specification For HINK 2.13"EPD

Model NO.: LCMEN2R13EFC1

Product VER:A0

Customer Approval

Customer	
Approval By	
Date Of Approval	

It will be agreed by the receiver,if not sign back the Specification within 15days.

Prepared By	Checked By	Approval By

睿智皓天（成都）信息技术有限公司

File Name	Specification For HINK 2.13" EPD	Module Number ""	LCMEN2R13EFC1
Version	A0	Page Number	2 of 44

Version	Content	Date	Producer
A0	New release	2021/06/05	WXB

睿智皓天（成都）信息技术有限公司

File Name	Specification For HINK 2.13" EPD	Module Number ""	LCMEN2R13EFC1
Version	A0	Page Number	3 of 44

CONTENTS

1. GENERAL DESCRIPTION.....	3
2.FEATURES	3
3. APPLICATION	4
4. MECHANICAL SPECIFICATIONS	4
5. MECHANICAL DRAWING OF EPD MODULE.....	4
6. INPUT/OUTPUT TERMINALS	5
7.COMMAND DESCRIPTION	6
8 .HOST INTERFACES.....	32
9. POWER ON/OFF SEQUENCE.....	34
10. REFERENCE CIRCUIT.....	36
11. ABSOLUTE MAXIMUM RATINGS.....	38
12. DC CHARACTERISTICS.....	38
13. AC CHARACTERISTICS.....	39
14. POWER CONSUMPTION.....	41
15.OPTICAL CHARACTERISTICS	41
16. HANDLING, SAFETY AND ENVIROMENTAL REQUIREMENTS.....	43
17. RELIABILITY TEST	45
18. BLOCK DIAGRAM.....	46
19.PARTA/PARTB SPECIFICATION	46
20.POINT AND LINE STANDARD	47
?? HYPERLINK \L "_TOC67410655" 21.BARCODE.....	49
22.PACKING.....	50

睿智皓天（成都）信息技术有限公司

File Name	Specification For HINK 2.13" EPD	Module Number	LCMEN2R13EFC1
Version	A0	Page Number	4 of 44

1. General Description

LCMEN2R13EFC1 is an Active Matrix Electrophoretic Display (AMEPD), with interface and a reference system design. The 2.13" active area contains 122×250 pixels, and has 1-bit B/W full display capabilities. An integrated circuit contains gate buffer, source buffer, interface, timing control logic, oscillator, DC-DC, SRAM, LUT, VCOM and border are supplied with each panel.

2. Features

- 122×250 pixels display
- High contrast
- High reflectance
- Ultra wide viewing angle
- Ultra low power consumption
- Pure reflective mode
- Bi-stable display
- Commercial temperature range
- Landscape, portrait modes
- Hard-coat antiglare display surface
- Ultra Low current deep sleep mode
- On chip display RAM
- Serial peripheral interface available
- On-chip oscillator
- On-chip booster and regulator control for generating VCOM, Gate and Source driving voltage
- I2C signal master interface to read external temperature sensor I2C / built-in temperature sensor

3. Application

Electronic Shelf Label System

4. Mechanical Specifications

Parameter	Specifications	Unit	Remark
Screen Size	2.13	Inch	
Display Resolution	122(H)×250(V)	Pixel	Dpi:130
Active Area	23.71(H)×48.55(V)	mm	
Pixel Pitch	0.194×0.194	mm	
Pixel Configuration	Rectangle		
Outline Dimension	29.2(H)×59.2 (V) ×0.9(D)	mm	Without masking film
Weight	3±0.5	g	

睿智皓天（成都）信息技术有限公司

File Name	Specification For HINK 2.13" EPD	Module Number	LCMEN2R13EFC1
Version	A0	Page Number	5 of 44

5. Mechanical Drawing of EPD module

A0 confirmed	Signature	Date	REV	DESCRIPTION	REVISED DATE
			A0	initial version	WXB 20211017

FRONT VIEW

SIDE VIEW

BOTTOM VIEW

PIN	SIGNAL
1	NC
2	GDR
3	RESF
4	NC
5	VSH2
6	TSCL
7	TSDA
8	BST
9	BUSY
10	RES#
11	DC#
12	CS#
13	SCL
14	SDA
15	VDDIO
16	VCI
17	VSS
18	VDD
19	VPP
20	VSH1
21	VGH
22	VSL
23	VGL
24	VCOM

WISEVAST

ALL UNITS: mm	DATE	MODEL NUMBER:	SHEET: 1
DESIGN:			DATE: 20211017
CHK:	Ps:	P/N	PROJECTION
APP:			

1. DISPLAY MODE 2.13" ARRAY FOR EPD;

2. DRIVE IC: JD79656;

3. RESOLUTION: 122source X 250gate;

4. pixel size: 0.1943mm X 0.1942mm;

5. dpi: 130

6. Unspecified Tolerance: ±0.20;

7. Material conform to the ROHS&REACH standard;

8. * as the focus control size

睿智皓天（成都）信息技术有限公司

File Name	Specification For HINK 2.13" EPD	Module Number ""	LCMEN2R13EFC1
Version	A0	Page Number	6 of 44

6. Input/Output Terminals

Pin #	Single	Description	Remark
1	NC	No connection and do not connect with other NC pins	Keep Open
2	GDR	This pin is N-MOS gate control.	
3	RESE	Current sense input for control loop.	
4	NC	No connection and do not connect with other NC pins	Keep Open
5	VSHR	Positive source voltage for Red	
6	TSCL	I2C clock for external temperature sensor	Note 6-6
7	TSDA	I2C data for external temperature sensor	Note 6-6
8	BS	Input interface setting.	Note 6-5
9	BUSY_N	This pin indicates the driver status.	Note 6-4
10	RST_N	Global reset pin	Note 6-3
11	DC	Serial communication Command/Data input	Note 6-2
12	CSB	Serial communication chip select.	Note 6-1
13	SCL	Serial communication clock input.	
14	SDA	Serial communication data input.	
15	VDDIO	IO voltage supply	
16	VDD	Digital/Analog power.	
17	VSS	Digital ground	
18	VDD 15V	1.5V voltage input & output	
19	VMTP	MTP program power (10V)	
20	VSH	Positive source voltage	
21	VGH	Positive gate voltage	
22	VSL	Negative source voltage.	
23	VGL	Negative gate voltage.	
24	VCOM	VCOM driving voltage	

Note 6-1: This pin (CSB) is the chip select input connecting to the MCU. The chip is enabled for MCU communication: only when CSB is pulled LOW.

Note 6-2: This pin (DC) is Data/Command control pin connecting to the MCU.

L: Command H: data (default) Connect to VDD if BS=High.

Note 6-3: This pin (RST_N) is Global reset pin. Low reset. (normal pull high). When RST_N become low, driver will reset. All register will reset to default value. all driver function will disable. SD output and VCOM will be released to floating.

Note 6-4: This pin (BUSY_N) is Busy state output pin.

BUSY_N= "0" : Driver is busy, data/VCOM is transforming.

BUSY_N= "1" : non-busy. Host side can send command/data to driver.

Note 6-5: This pin (BS) is for 3-line SPI or 4-line SPI selection. When it is "Low", 4-line SPI is selected. When it is "High", 3-line SPI (9 bits SPI) is selected.

Note 6-6: If customer don't want to use external temperature sensors, please make TSCL and TSDA to be ground ,not NC.

睿智皓天（成都）信息技术有限公司

File Name	Specification For HINK 2.13" EPD	Module Number ""	LCMEN2R13EFC1
Version	A0	Page Number	7 of 44

7.COMMAND DESCRIPTION

R/W: 0: Write Cycle 1: Read Cycle D/CX: 0: Command / 1: Data D7-D0: -: Don't Care

1) R00H (PSR): Panel setting Register

R00H	Bit										
Inst/Para	R/W	D/CX	D7	D6	D5	D4	D3	D2	D1	D0	Code
PSR	W	0	0	0	0	0	0	0	0	0	00h
1 st Parameter	W	1	RES[1]	RES[0]	REG_EN	BWR	UD	SHL	SHD_N	RST_N	0Fh
2 nd Parameter	W	1	-	-		VCMZ	TS_AUTO	VGLTIEG	NORG	VC_LUTZ	09h

NOTE: "-" Don't care, can be set to VDD or GND level

Description	-The command defines as :										
	1st parameter										
	Bit	Name	Description								
	0	RST_N	RST_N function 1: no effect. (default) 0: Booster OFF, Register data are set to their default values, and SEG/BG/VCOM:floating								
	1	SHD_N	SHD_N function 0 : Booster OFF, register data are kept, and SEG/BG/VCOM are kept floating. 1 : Booster on. (default)								
	2	SHL	SHL function 0: Shift left; First data=Sn→Sn-1 →...→S2→Last data=S1. 1: Shift right: First data=S1→S2 →...→Sn-1→Last data=Sn. (default)								
	3	UD	UD function 0:Scan down; First line=Gn→Gn-1 →...→G2→Last line=G1. 1:Scan up; First line=G1→G2 →...→Gn-1→Last line=Gn. (default)								
	4	BWR	Color selection setting 0: Pixel with B/W/Red. Run both LU1 and LU2. (default) 1: Pixel with B/W. Run LU1 only								
	5	REG_EN	LUT selection setting 0 : Using LUT from MTP(default) 1 : Using LUT from register								
	7-6	RES[1,0]	Resolution setting 00: Display resolution is 32x250, S0~S31, G0~G249 (default) 01: Display resolution is 64x250, S0~S63, G0~G249 10: Display resolution is 96x250, S0~S95, G0~G249 11: Display resolution is 128x250, S0~S127, G0~G249								
	Notes:										
	1. When SHD_N become low, DCDC will turn off. Register and SRAM data will keep until VDD turn off. SD output and VCOM will base on previous condition and keep floating.										
	2. When RST_N become low, driver will reset. All register will reset to default value. All of the driver's functions will disable. SD output and VCOM will base on previous condition and keep floating.										

睿智皓天（成都）信息技术有限公司

File Name	Specification For HINK 2.13" EPD	Module Number ""	LCMEN2R13EFC1
Version	A0	Page Number	8 of 44

2 nd parameter	Bit	Name	Description
	0	VC_LUTZ	VCOM status function 0 : Display off, VCOM keep to power off 1 : Display off, VCOM is set to floating (default)
	1	NORG	VCOM status function 0 : No effect (default) 1 : Expect refreshing display, VCOM is tied to GND
	2	VGLTIEG	VGL power off status function 0 : Power off, VGL will be floating (default) 1 : Power off, VGL will be tied to GND
	3	TS_AUTO	Temperature sensing will be activated automatically one time 0 : Before enabling refresh, temperature sensing on 1 : Before enabling booster, temperature sensing on (default)
	4	VCMZ	VCOM status function 0 : No effect (default) 1 : VCOM is always floating
	Priority of VCOM setting: VCMZ > NORG > VC_LUTZ		
Restriction			

睿智皓天（成都）信息技术有限公司

File Name	Specification For HINK 2.13" EPD	Module Number ""	LCMEN2R13EFC1
Version	A0	Page Number	9 of 44

2) R01H (PWR): Power setting Register

R01H	Bit										
Inst/Para	R/W	D/CX	D7	D6	D5	D4	D3	D2	D1	D0	Code
PWR	W	0	0	0	0	0	0	0	0	1	01h
1 st Parameter	W	1	-	-	-	-	-	-	VDS_EN	VDG_EN	03h
2 nd Parameter	W	1	-	-	-	VCOM_HV	VGHL_LV[3]	VGHL_LV[2]	VGHL_LV[1]	VGHL_LV[0]	00h
3 rd Parameter	W	1	-	-	VSH [5]	VSH [4]	VSH [3]	VSH [2]	VSH [1]	VSH [0]	3Fh
4 th Parameter	W	1	-	-	VSL [5]	VSL [4]	VSL [3]	VSL [2]	VSL [1]	VSL [0]	3Fh
5 th Parameter	W	1	OPTEN	VSHR [6]	VSHR [5]	VSHR [4]	VSHR [3]	VSHR [2]	VSHR [1]	VSHR [0]	0Dh

NOTE: "-" Don't care, can be set to VDD or GND level

Description	-The command defines as :		
	1st Parameter:		
	Bit	Name	Description
	0	VDG_EN	Gate power selection. 0 : External VDNS power from VGH/VGL pins. (VDNG_EN open) 1 : Internal DCDC function for generate VGH/VGL. (default)
	1	VDS_EN	Source power selection. 0 : External source power from VSH/VSL/VSHR pins. 1 : Internal DC/DC function for generate VSH/VSL/VSHR (default)
	2nd Parameter:		
	Bit	Name	Description
	3-0	VGHL_LV	VGHL LV Voltage Level. code VGH/VGL Voltage 0000 VGH=20V,VGL=-20V(default) 0001 VGH=19V,VGL=-19V 0010 VGH=18V,VGL=-18V 0011 VGH=17V,VGL=-17V 0100 VGH=16V,VGL=-16V 0101 VGH=15V,VGL=-15V 0110 VGH=14V,VGL=-14V 0111 VGH=13V,VGL=-13V 1000 VGH=12V,VGL=-12V 1001 VGH=11V,VGL=-11V 1010 VGH=10V,VGL=-10V 1011 VGH=21V,VGL=-21V 1100 VGH=22V,VGL=-22V 1101 1110 1111 NA
	4	VCOM_HV	VCOM Voltage Level 0: VCOMH=VSH+VCOMDC ,VCOML=VSL+VCOMDC(Default) 1: VCOMH=VGH,VCOML=VGL
	3rd Parameter: Internal VSH power selection for B/W LUT. (Default value: 11111b)		
Bit	Name	Description	
5-0	VSH	Internal VSH power selection.	

睿智皓天（成都）信息技术有限公司

File Name	Specification For HINK 2.13" EPD	Module Number	LCMEN2R13EFC1
Version	A0	Page Number	10 of 44

VSH[5:0]	Voltage(V)	VSH[5:0]	Voltage(V)	VSH[5:0]	Voltage(V)
000000	00h	2.4	010110	16h	6.8
000001	01h	2.6	010111	17h	7
000010	02h	2.8	011000	18h	7.2
000011	03h	3	011001	19h	7.4
000100	04h	3.2	011010	1Ah	7.6
000101	05h	3.4	011011	1Bh	7.8
000110	06h	3.6	011100	1Ch	8
000111	07h	3.8	011101	1Dh	8.2
001000	08h	4	011110	1Eh	8.4
001001	09h	4.2	011111	1Fh	8.6
001010	0Ah	4.4	100000	20h	8.8
001011	0Bh	4.6	100001	21h	9
001100	0Ch	4.8	100010	22h	9.2
001101	0Dh	5	100011	23h	9.4
001110	0Eh	5.2	100100	24h	9.6
001111	0Fh	5.4	100101	25h	9.8
010000	10h	5.6	100110	26h	10
010001	11h	5.8	100111	27h	10.2
010010	12h	6	101000	28h	10.4
010011	13h	6.2	101001	29h	10.6
010100	14h	6.4	101010	2Ah	10.8
010101	15h	6.6	101011	2Bh	11

4th Parameter: Internal VSL power selection for B/W LUT. **Default value: 111111b)**

Bit	Name	Description								
5-0	VSL	Internal VSL power selection.								
		VSL[5:0]	Voltage(V)	VSL[5:0]	Voltage(V)	VSL[5:0]	Voltage(V)	VSL[5:0]	Voltage(V)	
		000000	00h	-2.4	010110	16h	-6.8	101100	2Ch	-11.2
		000001	01h	-2.6	010111	17h	-7	101101	2Dh	-11.4
		000010	02h	-2.8	011000	18h	-7.2	101110	2Eh	-11.6
		000011	03h	-3	011001	19h	-7.4	101111	2Fh	-11.8
		000100	04h	-3.2	011010	1Ah	-7.6	110000	30h	-12
		000101	05h	-3.4	011011	1Bh	-7.8	110001	31h	-12.2
		000110	06h	-3.6	011100	1Ch	-8	110010	32h	-12.4
		000111	07h	-3.8	011101	1Dh	-8.2	110011	33h	-12.6
		001000	08h	-4	011110	1Eh	-8.4	110100	34h	-12.8
		001001	09h	-4.2	011111	1Fh	-8.6	110101	35h	-13
		001010	0Ah	-4.4	100000	20h	-8.8	110110	36h	-13.2
		001011	0Bh	-4.6	100001	21h	-9	110111	37h	-13.4
		001100	0Ch	-4.8	100010	22h	-9.2	111000	38h	-13.6
		001101	0Dh	-5	100011	23h	-9.4	111001	39h	-13.8
		001110	0Eh	-5.2	100100	24h	-9.6	111010	3Ah	-14
		001111	0Fh	-5.4	100101	25h	-9.8	111011	3Bh	-14.2
		010000	10h	-5.6	100110	26h	-10	111100	3Ch	-14.4
		010001	11h	-5.8	100111	27h	-10.2	111101	3Dh	-14.6
		010010	12h	-6	101000	28h	-10.4	111110	3Eh	-14.8
		010011	13h	-6.2	101001	29h	-10.6	111111	3Fh	-15
		010100	14h	-6.4	101010	2Ah	-10.8			
		010101	15h	-6.6	101011	2Bh	-11			

5th Parameter: Internal VSHR power selection for Red LUT. (Default value: 00001111b)

OPTEN=1:enable step =0.1 voltage selection(2.4~15V)

Internal VSHR power selection for Red LUT.

Bit	Name	Description
5-0	VSHR	Internal VSHR power selection.

睿智皓天（成都）信息技术有限公司

File Name	Specification For HINK 2.13" EPD				Module Number				LCMEN2R13EFC1			
Version	A0				Page Number				11 of 44			
	VSHR[6.0]	Voltage (V)	VSHR[6.0]	Voltage (V)	VSHR[6.0]	Voltage (V)	VSHR[6.0]	Voltage (V)	VSHR[6.0]	Voltage (V)		
	0000000	00h	2.4	0100000	20h	5.6	1000000	40h	8.8	1100000	60h	12
	0000001	01h	2.5	0100001	21h	5.7	1000001	41h	8.9	1100001	61h	12.1
	0000010	02h	2.6	0100010	22h	5.8	1000010	42h	9	1100010	62h	12.2
	0000011	03h	2.7	0100011	23h	5.9	1000011	43h	9.1	1100011	63h	12.3
	0000100	04h	2.8	0100100	24h	6	1000100	44h	9.2	1100100	64h	12.4
	0000101	05h	2.9	0100101	25h	6.1	1000101	45h	9.3	1100101	65h	12.5
	0000110	06h	3	0100110	26h	6.2	1000110	46h	9.4	1100110	66h	12.6
	0000111	07h	3.1	0100111	27h	6.3	1000111	47h	9.5	1100111	67h	12.7
	0001000	08h	3.2	0101000	28h	6.4	1001000	48h	9.6	1101000	68h	12.8
	0001001	09h	3.3	0101001	29h	6.5	1001001	49h	9.7	1101001	69h	12.9
	0001010	0Ah	3.4	0101010	2Ah	6.6	1001010	4Ah	9.8	1101010	6Ah	13
	0001011	0Bh	3.5	0101011	2Bh	6.7	1001011	4Bh	9.9	1101011	6Bh	13.1
	0001100	0Ch	3.6	0101100	2Ch	6.8	1001100	4Ch	10	1101100	6Ch	13.2
	0001101	0Dh	3.7	0101101	2Dh	6.9	1001101	4Dh	10.1	1101101	6Dh	13.3
	0001110	0Eh	3.8	0101110	2Eh	7	1001110	4Eh	10.2	1101110	6Eh	13.4
	0001111	0Fh	3.9	0101111	2Fh	7.1	1001111	4Fh	10.3	1101111	6Fh	13.5
	0010000	10h	4	0110000	30h	7.2	1010000	50h	10.4	1110000	70h	13.6
	0010001	11h	4.1	0110001	31h	7.3	1010001	51h	10.5	1110001	71h	13.7
	0010010	12h	4.2	0110010	32h	7.4	1010010	52h	10.6	1110010	72h	13.8
	0010011	13h	4.3	0110011	33h	7.5	1010011	53h	10.7	1110011	73h	13.9
	0010100	14h	4.4	0110100	34h	7.6	1010100	54h	10.8	1110100	74h	14
	0010101	15h	4.5	0110101	35h	7.7	1010101	55h	10.9	1110101	75h	14.1
	0010110	16h	4.6	0110110	36h	7.8	1010110	56h	11	1110110	76h	14.2
	0010111	17h	4.7	0110111	37h	7.9	1010111	57h	11.1	1110111	77h	14.3
	0011000	18h	4.8	0111000	38h	8	1011000	58h	11.2	1111000	78h	14.4
	0011001	19h	4.9	0111001	39h	8.1	1011001	59h	11.3	1111001	79h	14.5
	0011010	1Ah	5	0111010	3Ah	8.2	1011010	5Ah	11.4	1111010	7Ah	14.6
	0011011	1Bh	5.1	0111011	3Bh	8.3	1011011	5Bh	11.5	1111011	7Bh	14.7
	0011100	1Ch	5.2	0111100	3Ch	8.4	1011100	5Ch	11.6	1111100	7Ch	14.8
	0011101	1Dh	5.3	0111101	3Dh	8.5	1011101	5Dh	11.7	1111101	7Dh	14.9
	0011110	1Eh	5.4	0111110	3Eh	8.6	1011110	5Eh	11.8	1111110	7Eh	15
	0011111	1Fh	5.5	0111111	3Fh	8.7	1011111	5Fh	11.9	others		

OPTEN=1:enable step0.2 voltage selection(2.4~15V)
 Internal VSHR power selection for Red LUT.

Bit	Name	Description

睿智皓天（成都）信息技术有限公司

File Name	Specification For HINK 2.13" EPD	Module Number""	LCMEN2R13EFC1
Version	A0	Page Number	12 of 44

6-0	VSHR	Internal VSHR power selection.							
		VSHR[5:0]	Voltage (V)	VSHR[5:0]	Voltage (V)	VSHR[5:0]	Voltage (V)	VSHR[5:0]	Voltage (V)
000000	00h	2.4	010110	16h	6.8	101100	2Ch	11.2	
000001	01h	2.6	010111	17h	7.0	101101	2Dh	11.4	
000010	02h	2.8	011000	18h	7.2	101110	2Eh	11.6	
000011	03h	3.0	011001	19h	7.4	101111	2Fh	11.8	
000100	04h	3.2	011010	1Ah	7.6	110000	30h	12	
000101	05h	3.4	011011	1Bh	7.8	110001	31h	12.2	
000110	06h	3.6	011100	1Ch	8.0	110010	32h	12.4	
000111	07h	3.8	011101	1Dh	8.2	110011	33h	12.6	
001000	08h	4	011110	1Eh	8.4	110100	34h	12.8	
001001	09h	4.2	011111	1Fh	8.6	110101	35h	13	
001010	0Ah	4.4	100000	20h	8.8	110110	36h	13.2	
001011	0Bh	4.6	100001	21h	9.0	110111	37h	13.4	
001100	0Ch	4.8	100010	22h	9.2	111000	38h	13.6	
001101	0Dh	5.0	100011	23h	9.4	111001	39h	13.8	
001110	0Eh	5.2	100100	24h	9.6	111010	3Ah	14	
001111	0Fh	5.4	100101	25h	9.8	111011	3Bh	14.2	
010000	10h	5.6	100110	26h	10.0	111100	3Ch	14.4	
010001	11h	5.8	100111	27h	10.2	111101	3Dh	14.6	
010010	12h	6.0	101000	28h	10.4	111110	3Eh	14.8	
010011	13h	6.2	101001	29h	10.6	111111	3Fh	15	
010100	14h	6.4	101010	2Ah	10.8				
010101	15h	6.6	101011	2Bh	11.0				

Note:1.VSH>VSHR

睿智皓天（成都）信息技术有限公司

File Name	Specification For HINK 2.13" EPD	Module Number ""	LCMEN2R13EFC1
Version	A0	Page Number	13 of 44

3) R02H (POF): Power OFF Command

R02H	Bit										
Inst/Para	R/W	D/CX	D7	D6	D5	D4	D3	D2	D1	D0	Code
POF	W	0	0	0	0	0	0	0	1	0	02H

NOTE: “-” Don’t care, can be set to VDD or GND level

Description	<p>-The command defines as :</p> <ul style="list-style-type: none"> ● After power off command, driver will power off base on power off sequence. ● After power off command, BUSY_N signal will drop from high to low. When finish the power off sequence, BUSY_N signal will rise from low to high. ● Power off command will turn off charge pump, T-con, source driver, gate driver, VCOM, temperature sensor, but register and SRAM data will keep until VDD off. ● SD output and VCOM will keep floating.
Restriction	

4) R03H (PFS): Power off Sequence Setting Register

R03H	Bit										
Inst/Para	R/W	D/CX	D7	D6	D5	D4	D3	D2	D1	D0	Code
PFS	W	0	0	0	0	0	0	0	1	1	03H
1 st Parameter	W	1	-	-	T_VDS_OFF [1]	T_VDS_OFF [0]	T_VSHR_OFF [1]	T_VSHR_OFF [0]	-	-	00h

NOTE: “ - ” Don’ t care, can be set to VDD or GND level

Description	<p>-The command defines as :</p> <p>1stParameter:</p> <table border="1"> <thead> <tr> <th>Bit</th> <th>Name</th> <th>Description</th> </tr> </thead> <tbody> <tr> <td>5-4</td> <td>T_VDS_OFF</td> <td>00: 1 frame (default) 01: 2 frame 10: 3 frame 11: 4 frame</td> </tr> <tr> <td>3-2</td> <td>T_VSHR_OFF</td> <td>00: 1 frame (default) 01: 2 frame 10: 3 frame 11: 4 frame</td> </tr> </tbody> </table>	Bit	Name	Description	5-4	T_VDS_OFF	00: 1 frame (default) 01: 2 frame 10: 3 frame 11: 4 frame	3-2	T_VSHR_OFF	00: 1 frame (default) 01: 2 frame 10: 3 frame 11: 4 frame
Bit	Name	Description								
5-4	T_VDS_OFF	00: 1 frame (default) 01: 2 frame 10: 3 frame 11: 4 frame								
3-2	T_VSHR_OFF	00: 1 frame (default) 01: 2 frame 10: 3 frame 11: 4 frame								
Restriction										

5) R04H (PON): Power ON Command

R04H	Bit										
Inst/Para	R/W	D/CX	D7	D6	D5	D4	D3	D2	D1	D0	Code
PON	W	0	0	0	0	0	0	1	0	0	04H

NOTE: “ - ” Don’ t care, can be set to VDD or GND level

Description	<p>-The command defines as :</p> <ul style="list-style-type: none"> ● After power on command, driver will power on base on power on sequence. ● After power on command, BUSY_N signal will drop from high to low. When finishing the power on sequence, BUSY_N signal will rise from low to high.
Restriction	This command only active when BUSY_N = “1”.

睿智皓天（成都）信息技术有限公司

File Name	Specification For HINK 2.13" EPD	Module Number ""	LCMEN2R13EFC1
Version	A0	Page Number	14 of 44

6) R05H (PMES): Power ON Measure Command

R05H	Bit										
Inst/Para	R/W	D/CX	D7	D6	D5	D4	D3	D2	D1	D0	Code
PMES	W	0	0	0	0	0	0	1	0	1	05H

NOTE: " -" Don' t care, can be set to VDD or GND level

Description	-The command defines as : ●If user wants to read temperature sensor or detect low power in power off mode, user has to send this command. After power on measure command, driver will switch on relevant commend with Low Power detection (R51H) and temperature measurement. (R40H).
Restriction	This command only active when BUSY_N = "1".

7) R06H (BTST): Booster Soft Start Command

R06H	Bit										
Inst/Para	R/W	D/CX	D7	D6	D5	D4	D3	D2	D1	D0	Code
BTST	W	0	0	0	0	0	0	1	1	0	06H
1 st Parameter	W	1	BT_PHA[7]	BT_PHA[6]	BT_PHA[5]	BT_PHA[4]	BT_PHA[3]	BT_PHA[2]	BT_PHA[1]	BT_PHA[0]	17h
2 nd Parameter	W	1	BT_PHB[7]	BT_PHB[6]	BT_PHB[5]	BT_PHB[4]	BT_PHB[3]	BT_PHB[2]	BT_PHB[1]	BT_PHB[0]	17h
3 rd Parameter	W	1	-	-	BT_PHC[5]	BT_PHC[4]	BT_PHC[3]	BT_PHC[2]	BT_PHC[1]	BT_PHC[0]	17h
4 th Parameter	W	1	1	0	1	0	0	1	0	1	A5h
5 th Parameter	W	1	FT_PHC[3]	FT_PHC[2]	FT_PHC[1]	FT_PHC[0]	FT_PHB[3]	FT_PHB[2]	FT_PHB[1]	FT_PHB[0]	00h

NOTE: " -" Don' t care, can be set to VDD or GND level

睿智皓天（成都）信息技术有限公司

File Name	Specification For HINK 2.13" EPD	Module Number	LCMEN2R13EFC1
Version	A0	Page Number	15 of 44

Description

-This command only active when BUSY_N = " 1" .

-The command define as follows:

1st Parameter:

Bit	Name	Description
2-0	Driving strength of phase A	000: period 1
		001: period 2
		010: period 3
		011: period 4
		100: period 5
		101: period 6
		110: period 7
		111: period 8 (default)
5-3		000: Strength 1
		001: Strength 2
		010: Strength 3 (default)
		011: Strength 4
		100: Strength 5
		101: Strength 6
		110: Strength 7
		111: Strength 8
7-6	Soft start period of phase A	00: 10mS (default)
		01: 20mS
		10: 30mS
		11: 40mS

2nd Parameter:

Bit	Name	Description
2-0	Driving strength of phase B	000: period 1
		001: period 2
		010: period 3
		011: period 4
		100: period 5
		101: period 6
		110: period 7
		111: period 8 (default)
5-3		000: Strength 1
		001: Strength 2
		010: Strength 3 (default)
		011: Strength 4
		100: Strength 5
		101: Strength 6
		110: Strength 7
		111: Strength 8
7-6	Soft start period of phase B	00: 10mS (default)
		01: 20mS
		10: 30mS
		11: 40mS

3rd Parameter:

Bit	Name	Description
-----	------	-------------

睿智皓天（成都）信息技术有限公司

File Name	Specification For HINK 2.13" EPD		Module Number	LCMEN2R13EFC1															
Version	A0		Page Number	16 of 44															
	2-0	Minimum OFF time setting of GDR in phase C	000: period 1 001: period 2 010: period 3 011: period 4 100: period 5 101: period 6 110: period 7 111: period 8 (default)																
	5-3	Driving strength of phase C	000: Strength 1 001: Strength 2 010: Strength 3 (default) 011: Strength 4 100: Strength 5 101: Strength 6 110: Strength 7 111: Strength 8																
<p>4th Parameter: This parameter is a check code. The command would be excited if check code = 0xA5, and the 5th Parameter would be available.</p> <p>5th Parameter:</p> <table border="1"> <thead> <tr> <th>Bit</th> <th>Name</th> <th>Description</th> </tr> </thead> <tbody> <tr> <td>1-0</td> <td>Minimum OFF time setting of GDR in phase B</td> <td>00: period sel 1 (default) 01: period sel 2 10: period sel 3 11: period sel 4</td> </tr> <tr> <td>3-2</td> <td>Driving strength of phase B</td> <td>00: Strength sel 1 01: Strength sel 2 10: Strength sel 3 11: Strength sel 4</td> </tr> <tr> <td>5-4</td> <td>Minimum OFF time setting of GDR in phase C</td> <td>00: period sel 1 (default) 01: period sel 2 10: period sel 3 11: period sel 4</td> </tr> <tr> <td>7-6</td> <td>Driving strength of phase C</td> <td>00: Strength sel 1 01: Strength sel 2 10: Strength sel 3 11: Strength sel 4</td> </tr> </tbody> </table>					Bit	Name	Description	1-0	Minimum OFF time setting of GDR in phase B	00: period sel 1 (default) 01: period sel 2 10: period sel 3 11: period sel 4	3-2	Driving strength of phase B	00: Strength sel 1 01: Strength sel 2 10: Strength sel 3 11: Strength sel 4	5-4	Minimum OFF time setting of GDR in phase C	00: period sel 1 (default) 01: period sel 2 10: period sel 3 11: period sel 4	7-6	Driving strength of phase C	00: Strength sel 1 01: Strength sel 2 10: Strength sel 3 11: Strength sel 4
Bit	Name	Description																	
1-0	Minimum OFF time setting of GDR in phase B	00: period sel 1 (default) 01: period sel 2 10: period sel 3 11: period sel 4																	
3-2	Driving strength of phase B	00: Strength sel 1 01: Strength sel 2 10: Strength sel 3 11: Strength sel 4																	
5-4	Minimum OFF time setting of GDR in phase C	00: period sel 1 (default) 01: period sel 2 10: period sel 3 11: period sel 4																	
7-6	Driving strength of phase C	00: Strength sel 1 01: Strength sel 2 10: Strength sel 3 11: Strength sel 4																	
Restriction																			

睿智皓天（成都）信息技术有限公司

File Name	Specification For HINK 2.13" EPD	Module Number	LCMEN2R13EFC1
Version	A0	Page Number	17 of 44

8) R07H (DSL P): Deep Sleep Command

R07H	Bit										
Inst/Para	R/W	D/CX	D7	D6	D5	D4	D3	D2	D1	D0	Code
DSL P	W	0	0	0	0	0	0	1	1	1	07H
1 st Parameter	W	1	1	0	1	0	0	1	0	1	A5h

NOTE: “-” Don’t care, can be set to VDD or GND level

Description	The command define as follows: After this command is transmitted, the chip would enter the deep-sleep mode to save power. The deep sleep mode would return to standby by hardware reset. The only one parameter is a check code, the command would be excited if check code = 0xA5.
Restriction	This command only active when BUSY_N = “1”.

9) R10H (DTM1): Data Start transmission 1 Register

R10H	Bit										
Inst/Para	R/W	D/CX	D7	D6	D5	D4	D3	D2	D1	D0	Code
DTM1	W	0	0	0	0	1	0	0	0	0	10H
1 st Parameter	W	1	KPixel1	KPixel2	KPixel3	KPixel4	KPixel5	KPixel6	KPixel7	KPixel8	00h
2 nd Parameter	W	1									00h
...	W	1									00h
M th Parameter	W	1	KPixel(n-7)	KPixel(n-6)	KPixel(n-5)	KPixel(n-4)	KPixel(n-3)	KPixel(n-2)	KPixel(n-1)	KPixel(n)	00h

NOTE: “ - ” Don’ t care, can be set to VDD or GND level

Description	The command define as follows: The register is indicates that user start to transmit data, then write to SRAM. While data transmission complete, user must send command 11H. Then chip will start to send data/VCOM for panel. In B/W mode, this command writes “OLD” data to SRAM. In B/W/Red mode, this command writes “B/W” data to SRAM. In Program mode, this command writes “OTP” data to SRAM for programming.
Restriction	

10) R11H (DSP): Data Stop Command

R11H	Bit										
Inst/Para	R/W	D/CX	D7	D6	D5	D4	D3	D2	D1	D0	Code
DSP	W	0	0	0	0	1	0	0	0	1	11H
1 st Parameter	R	1	Data_flag	-	-	-	-	-	-	-	00h

NOTE: “ - ” Don’ t care, can be set to VDD or GND level

Description	-The command defines as : <ul style="list-style-type: none"> While finished the data transmitting, user must send this command to driver and read Data_flag information. 1st Parameter: <table border="1" style="margin-left: 20px;"> <thead> <tr> <th>Bit</th> <th>Name</th> <th>Description</th> </tr> </thead> <tbody> <tr> <td>7</td> <td>-</td> <td>0: Driver didn’t receive all the data. 1: Driver has already received all of the one frame data.</td> </tr> </tbody> </table> After “Data Start” (10h) or “Data Stop” (11h) commands and when data_flag=1, BUSY_N signal will become “0” and the refreshing of panel starts.	Bit	Name	Description	7	-	0: Driver didn’t receive all the data. 1: Driver has already received all of the one frame data.
Bit	Name	Description					
7	-	0: Driver didn’t receive all the data. 1: Driver has already received all of the one frame data.					
Restriction	This command only actives when BUSY_N = “1”.						

睿智皓天（成都）信息技术有限公司

File Name	Specification For HINK 2.13" EPD	Module Number	LCMEN2R13EFC1
Version	A0	Page Number	18 of 44

11) R12H (DRF): Display Refresh Command

R12H	Bit										
Inst/Para	R/W	D/CX	D7	D6	D5	D4	D3	D2	D1	D0	Code
DRF	W	0	0	0	0	1	0	0	1	0	12H

NOTE: “ - ” Don’ t care, can be set to VDD or GND level

Description	-The command defines as : <ul style="list-style-type: none"> While users send this command, driver will refresh display (data/VCOM) base on SRAM data and LUT. After display refresh command, BUSY_N signal will become “0”.
Restriction	This command only actives when BUSY_N = “1”.

12) R13H (DTM2): Data Start transmission 2 Register

R13H	Bit										
Inst/Para	R/W	D/CX	D7	D6	D5	D4	D3	D2	D1	D0	Code
DTM2	W	0	0	0	0	1	0	0	1	1	13H
1 st Parameter	W	1	KPixel1	KPixel2	KPixel3	KPixel4	KPixel5	KPixel6	KPixel7	KPixel8	00h
2 nd Parameter	W	1									00h
...	W	1									00h
M th Parameter	W	1	KPixel(n-7)	KPixel(n-6)	KPixel(n-5)	KPixel(n-4)	KPixel(n-3)	KPixel(n-2)	KPixel(n-1)	KPixel(n)	00h

NOTE: “ - ” Don’ t care, can be set to VDD or GND level

Description	The command define as follows: The register is indicates that user start to transmit data, then write to SRAM. While data transmission complete, user must send command 11H. Then chip will start to send data/VCOM for panel. In B/W mode, this command writes “NEW” data to SRAM. In B/W/Red mode, this command writes “RED” data to SRAM.
Restriction	

13) R17H (AUTO): Auto Sequence

R17H	Bit										
Inst/Para	R/W	D/CX	D7	D6	D5	D4	D3	D2	D1	D0	Code
Auto Sequence	W	0	0	0	0	1	0	1	1	1	17H
1 st Parameter	W	1	Code[7]	Code[6]	Code[5]	Code[4]	Code[3]	Code[2]	Code[1]	Code[0]	A5h

Description	The command can enable the internal sequence to execute several commands continuously. The successive execution can minimize idle time to avoid unnecessary power consumption and reduce the complexity of host’s control procedure. The sequence contains several operations, including PON, DRF, POF, DSLP. AUTO (0x17) + Code(0xA5) = (PON→DRF→POF) AUTO (0x17) + Code(0xA7) = (PON→DRF→POF→DSLP)
Restriction	This command only actives when BUSY_N = “1”.

睿智皓天（成都）信息技术有限公司

File Name	Specification For HINK 2.13" EPD	Module Number	LCMEN2R13EFC1
Version	A0	Page Number	19 of 44

14) R18H (BIST): BIST mode Command

R07H	Bit										
Inst/Para	R/W	D/CX	D7	D6	D5	D4	D3	D2	D1	D0	Code
BIST	W	0	0	0	0	1	1	0	0	0	18H
1 st Parameter	W	1	1	0	1	0	0	1	0	1	A5h
2 nd Parameter	W	1	1	0	1	0	0	1	0	1	A5h

NOTE: " - " Don' t care, can be set to VDD or GND level

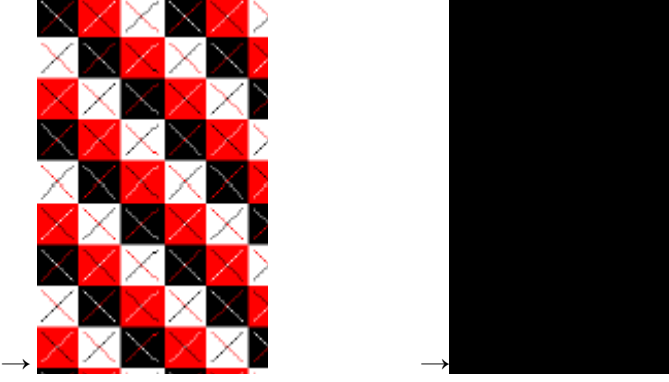
Description	<p>-The command define as follows: This command use only BWR mode.</p> <ul style="list-style-type: none"> ● 1st Parameter: (BIST once) This parameter is a check code. After this parameter is transmitted, the chip would enter the BIST mode, and display build-in pattern which could be decided by user in R19H (BIST_PS) command. The command would be excited if check code = 0xA5. While finished the BIST flow, the check code will be clear to 0x00. <p>The flow as below: PON→DTM→DSP→POFF</p>  <p>BIST pattern</p> <ul style="list-style-type: none"> ● 2nd Parameter: (BIST auto run) This parameter is a check code. After this parameter is transmitted, the chip would enter the BIST mode, and display build-in pattern auto run. The command would be excited if check code = 0xA5. The BIST auto run flow will be stop when the check code =0x00. <p>The flow as below: PON→DTM→DSP→DTM→DSP→...→DTM→DSP→POFF (check code =0x00)</p>  <p>Check pattern Black pattern</p>
-------------	---

睿智皓天（成都）信息技术有限公司

File Name	Specification For HINK 2.13" EPD	Module Number	LCMEN2R13EFC1
Version	A0	Page Number	20 of 44
	<p>White pattern W</p> <p>Red pattern</p> <p>Check pattern 2 • BIST pattern (repeat)</p>		
Restriction	- This command only actives after hardware reset. - The BUSY flag would change state from 0 to 1 while the command is completed - The DEBUG[6] pin is HW pin control(only auto run)		

15) R19H (BIST_PS): Pattern Selection in BIST

R19H	Bit											
Inst/Para	R/W	D/CX	D7	D6	D5	D4	D3	D2	D1	D0	Code	
Auto Sequence	W	0	0	0	0	1	1	0	0	1	19H	
1 st Parameter	W	1	-	-	-	-	-	BSIT_PS[2:0]			00h	
2 nd Parameter	W	1	W [7:3]					-			00h	
3 rd Parameter	W	1	L[7:0]									00h
4 th Parameter	W	1	X1[7:3]				0	0	0			00h
5 th Parameter	W	1	Y1[7:0]									00h
6 th Parameter	W	1	X2[7:3]				1	1	1			00h
7 th Parameter	W	1	Y2[7:0]									00h

Description	The command can decide which BIST pattern you would like to show. 1st Parameter 000: check pattern 001: Black pattern 010: White pattern 011: Red pattern 100: check pattern 2 Note: R19 should be determined before R18. 2nd ~7th Parameter : check pattern 2 setting W[7:3]: Red block width
-------------	---

睿智皓天（成都）信息技术有限公司

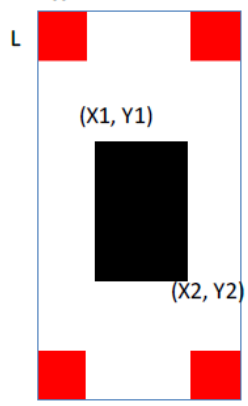
File Name	Specification For HINK 2.13" EPD	Module Number	LCMEN2R13EFC1
Version	A0	Page Number	21 of 44
	<p>L[7:0]: Red block Length X1[7:3]: Black block X star point Y1[7:0]: Black block Y star point X2[7:3]: Black block X end point Y2[7:0]: Black block Y end point</p>  <p>Note: 1. $W > H/2 \rightarrow W = W/4$ 2. $L > V/2 \rightarrow L = V/4$ 3. $X2 > X1$ 4. $Y2 > Y1$</p>		
Restriction	This command only actives when BUSY_N = "1".		

16) R40H (TSC): Temperature Sensor Command

R40H Inst/Para	Bit										
	R/W	D/CX	D7	D6	D5	D4	D3	D2	D1	D0	Code
TSC	W	0	0	1	0	0	0	0	0	0	40H
1 st Parameter	R	1	D10/TS[9]	D9/TS[8]	D8/TS[7]	D7/TS[6]	D6/TS[5]	D5/TS[4]	D4/TS[3]	D3/TS[2]	-
2 nd Parameter	R	1	D2/TS[1]	D1/TS[0]	D0	-	-	-	-	-	-

NOTE: " - " Don' t care, can be set to VDD or GND level

睿智皓天（成都）信息技术有限公司

File Name	Specification For HINK 2.13" EPD	Module Number	LCMEN2R13EFC1
Version	A0	Page Number	22 of 44

Description

-The command define as follows:
 This command indicates the temperature value.
 If R41H(TSE) bit7 set to 0, this command reads internal temperature sensor value.
 If R41H(TSE) bit7 set to 1, this command reads external (LM75) temperature sensor value.

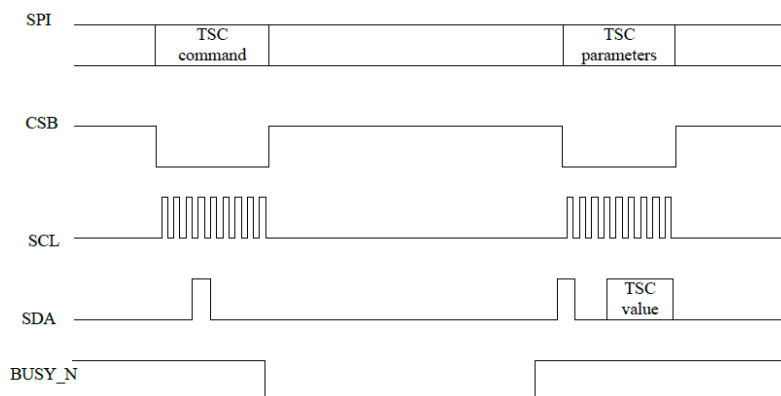

TS[9:2]/D[10:3]	T(°C)	TS[9:2]/D[10:3]	T(°C)	TS[9:2]/D[10:3]	T(°C)
11100111	-25	00000000	0	00011001	25
11101000	-24	00000001	1	00011010	26
11101001	-23	00000010	2	00011011	27
11101010	-22	00000011	3	00011100	28
11101011	-21	00000100	4	00011101	29
11101100	-20	00000101	5	00011110	30
11101101	-19	00000110	6	00011111	31
11101110	-18	00000111	7	00100000	32
11101111	-17	00001000	8	00100001	33
11110000	-16	00001001	9	00100010	34
11110001	-15	00001010	10	00100011	35
11110010	-14	00001011	11	00100100	36
11110011	-13	00001100	12	00100101	37
11110100	-12	00001101	13	00100110	38
11110101	-11	00001110	14	00100111	39
11110110	-10	00001111	15	00101000	40
11110111	-9	00010000	16	00101001	41
11111000	-8	00010001	17	00101010	42
11111001	-7	00010010	18	00101011	43
11111010	-6	00010011	19	00101100	44
11111011	-5	00010100	20	00101101	45
11111100	-4	00010101	21	00101110	46
11111101	-3	00010110	22	00101111	47
11111110	-2	00010111	23	00110000	48
11111111	-1	00011000	24	00110001	49

TS[1:0]	T(° C)
00	+0
01	+0.25
10	+0.5
11	+0.75

Restriction This command only actives when BUSY_N = "1".

17) R41H (TSE): Temperature Sensor Calibration Register

睿智皓天（成都）信息技术有限公司

File Name	Specification For HINK 2.13" EPD	Module Number	LCMEN2R13EFC1
Version	A0	Page Number	23 of 44

R41H	Bit										
Inst/Para	R/W	D/CX	D7	D6	D5	D4	D3	D2	D1	D0	Code
TSE	W	0	0	1	0	0	0	0	0	1	41H
1 st Parameter	W	1	TSE	-	TO[5]	TO[4]	TO[3]	TO[2]	TO[1]	TO[0]	00h

NOTE: " - " Don't care, can be set to VDD or GND level

Description	<p>-The command defines as: This command indicates the driver IC temperature sensor enable and calibration function. Reserve one temperature offset TO[3:0] for calibration 1. TO[3]: mean '+' or '-', while 0 is '+' ; 1 is '-' 2. TO[2:0]: mean temperature offset value</p>	
	Bit	Description
	3-0	<p>Temperature level: 0000: +0°C (default) 0001: +1°C 0010: +2°C 0011: +3°C 0100: +4°C 0101: +5°C 0110: +6°C 0111: +7°C 1000: -8°C 1001: -7°C 1010: -6°C 1011: -5°C 1100: -4°C 1101: -3°C 1110: -2°C 1111: -1°C</p>
	5-4	<p>00: +0.0°C (default) 01: +0.25°C 10: +0.5°C 11: +0.75°C</p>
7	<p>Internal temperature sensor enable 0: Internal temperature sensor enable.(default) 1: Internal temperature sensor disable, using external temperature sensor.</p>	
Restriction	This command only actives after R04H(PON) or R05H(PMES)	

睿智皓天（成都）信息技术有限公司

File Name	Specification For HINK 2.13" EPD	Module Number	LCMEN2R13EFC1
Version	A0	Page Number	24 of 44

18) R42H (TSW): Temperature Sensor Write Register

R42H	Bit										
Inst/Para	R/W	D/CX	D7	D6	D5	D4	D3	D2	D1	D0	Code
TSW	W	0	0	1	0	0	0	0	1	0	42H
1 st Parameter	W	1	WATTR[7]	WATTR[6]	WATTR[5]	WATTR[4]	WATTR[3]	WATTR[2]	WATTR[1]	WATTR[0]	00h
2 nd Parameter	W	1	WMSB[7]	WMSB[6]	WMSB[5]	WMSB[4]	WMSB[3]	WMSB[2]	WMSB[1]	WMSB[0]	00h
3 rd Parameter	W	1	WLSB[7]	WLSB[6]	WLSB[5]	WLSB[4]	WLSB[3]	WLSB[2]	WLSB[1]	WLSB[0]	00h

NOTE: " - " Don' t care, can be set to VDD or GND level

Description	-The command defines as: This command writes the temperature. 1st Parameter:										
	Bit	temperature									
	2-0	Pointer setting									
	5-3	User-defined address bits (A2, A1, A0)									
	7-6	I2C Write Byte Number 00: 1 byte (head byte only) 01: 2 bytes (head byte + pointer) 10: 3 bytes (head byte + pointer + 1st parameter) 11: 4 bytes (head byte + pointer + 1st parameter + 2nd parameter)									
	2nd Parameter:										
Bit	temperature										
7-0	MSByte of write-data to external temperature sensor										
3rd Parameter:											
Bit	temperature										
7-0	LSByte of write-data to external temperature sensor										
Restriction	This command only actives after R04H(PON) or R05H(PMES)										

19)R43H (TSR): Temperature Sensor Read Register

R43H	Bit										
Inst/Para	R/W	D/CX	D7	D6	D5	D4	D3	D2	D1	D0	Code
TSC	W	0	0	1	0	0	0	0	1	1	43H
1 st Parameter	R	1	RMSB[7]	RMSB[6]	RMSB[5]	RMSB[4]	RMSB[3]	RMSB[2]	RMSB[1]	RMSB[0]	-
2 nd Parameter	R	1	RLSB[7]	RLSB[6]	RLSB[5]	RLSB[4]	RLSB[3]	RLSB[2]	RLSB[1]	RLSB[0]	-

NOTE: " - " Don' t care, can be set to VDD or GND level

Description	-The command defines as: This command reads the temperature sensed by the temperature sensor. 1st Parameter:											
	Bit	temperature										
	7-0	MSByte of read-data from external temperature sensor										
	2nd Parameter:											
	Bit	temperature										
	7-0	LSByte of write-data from external temperature sensor										

睿智皓天（成都）信息技术有限公司

File Name	Specification For HINK 2.13" EPD	Module Number	LCMEN2R13EFC1
Version	A0	Page Number	25 of 44
Restriction	This command only actives after R04H(PON) or R05H(PMES)		

20)R50H (CDI): VCOM and DATA interval setting Register

R50H	Bit										
Inst/Para	R/W	D/CX	D7	D6	D5	D4	D3	D2	D1	D0	Code
CDI	W	0	0	1	0	1	0	0	0	0	50H
1 st Parameter	W	1	VBD[1]	VBD[0]	DDX[1]	DDX[0]	CDI[3]	CDI[2]	CDI[1]	CDI[0]	D7h

NOTE: " -" Don' t care, can be set to VDD or GND level

Description	<p>-The command defines as: 1st Parameter: CDI[1:0]: This command indicates the interval of VCOM and data output. When setting the vertical back porch, the total blanking will be keep (20hsync). 2nd Parameter:</p>	
	Bit	<p>3-0 Vcom and data interval 0000: 17 hsync 0001:16 hsync 0010:15 hsync 0011:14 hsync 0100:13 hsync 0101:12 hsync 0110:11 hsync 0111:10 hsync 1000:9 hsync 1001:8 hsync 1010:7 hsync 1011:6 hsync 1100:5 hsync 1101:4 hsync 1110:3 hsync 1111:2 hsync</p>

睿智皓天（成都）信息技术有限公司

File Name	Specification For HINK 2.13" EPD	Module Number	LCMEN2R13EFC1
Version	A0	Page Number	26 of 44

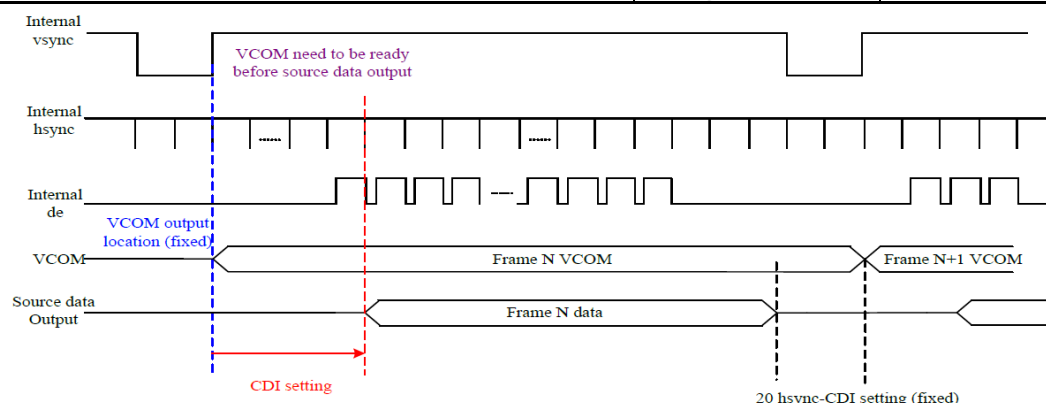

VBD[1:0]: Border data selection.

B/W/Red mode(BWR=0)

Bit 4	Bit7-6	Description
DDX[0]	VBD[1:0]	LUT
0	00	Floating
	01	LUTR
	10	LUTW
	11	LUTB
1(default)	00	LUTB
	01	LUTW
	10	LUTR
	11(default)	Floating (default)

B/W mode(BWR=1)

Bit 4	Bit7-6	Description
DDX[0]	VBD[1:0]	LUT
0	00	Floating
	01	LUTBW (1->0)
	10	LUTWB (0->1)
	11	Floating
1(default)	00	Floating
	01	LUTWB (0->1)
	10	LUTBW (1->0)
	11	Floating (default)

Border output voltage level: The level selection is based on mapping LUT data.

Level Selection:

00b: VCOM

01b: VSH

10b: VSL

11b: VSHR

DDX[1:0]: Data polarity

1.DDX[1] for RED data, DDX[0] for BW data in the B/W/Red mode

2.DDX[0] for B/W mode

睿智皓天（成都）信息技术有限公司

File Name	Specification For HINK 2.13" EPD	Module Number	LCMEN2R13EFC1																																																																																		
Version	A0	Page Number	27 of 44																																																																																		
<p>B/W/Red mode(BWR=0) DDX[1] is for RED data DDX[0] is for B/W data</p> <table border="1" style="width: 100%; border-collapse: collapse;"> <thead> <tr> <th style="width: 20%;">Bit 5-4</th> <th style="width: 40%;">Description</th> <th style="width: 40%;"></th> </tr> </thead> <tbody> <tr> <td>DDX[1:0]</td> <td>Data (Red/B/W)</td> <td>LUT</td> </tr> <tr> <td rowspan="4">00</td> <td>00</td> <td>LUTW</td> </tr> <tr> <td>01</td> <td>LUTB</td> </tr> <tr> <td>10</td> <td>LUTR</td> </tr> <tr> <td>11</td> <td>LUTR</td> </tr> <tr> <td rowspan="4">01(default)</td> <td>00</td> <td>LUTB</td> </tr> <tr> <td>01</td> <td>LUT2</td> </tr> <tr> <td>10</td> <td>LUTR</td> </tr> <tr> <td>11</td> <td>LUTR</td> </tr> <tr> <td rowspan="4">10</td> <td>00</td> <td>LUTR</td> </tr> <tr> <td>01</td> <td>LUTR</td> </tr> <tr> <td>10</td> <td>LUTW</td> </tr> <tr> <td>11</td> <td>LUTB</td> </tr> <tr> <td rowspan="4">11</td> <td>00</td> <td>LUTR</td> </tr> <tr> <td>01</td> <td>LUTR</td> </tr> <tr> <td>10</td> <td>LUTB</td> </tr> <tr> <td>11</td> <td>LUTW</td> </tr> </tbody> </table> <p>B/W mode (BWR=1) DDX[1]=0 is for BW mode with NEW/OLD</p> <table border="1" style="width: 100%; border-collapse: collapse;"> <thead> <tr> <th style="width: 20%;">Bit 5-4</th> <th style="width: 40%;">Description</th> <th style="width: 40%;"></th> </tr> </thead> <tbody> <tr> <td>DDX[1:0]</td> <td>Data (B/W)</td> <td>LUT</td> </tr> <tr> <td rowspan="4">00</td> <td>00</td> <td>LUTWW0->0)</td> </tr> <tr> <td>01</td> <td>LUTBW(1->0)</td> </tr> <tr> <td>10</td> <td>LUTWB(0->1)</td> </tr> <tr> <td>11</td> <td>LUTBB(1->1)</td> </tr> <tr> <td rowspan="4">01(default)</td> <td>00</td> <td>LUTBB(0->0)</td> </tr> <tr> <td>01</td> <td>LUTWB(1->0)</td> </tr> <tr> <td>10</td> <td>LUTBW(0->1)</td> </tr> <tr> <td>11</td> <td>LUTWW(1->1)</td> </tr> </tbody> </table> <p>DDX[1]=1 is for BW mode without NEW/OLD</p> <table border="1" style="width: 100%; border-collapse: collapse;"> <thead> <tr> <th style="width: 20%;">Bit 5-4</th> <th style="width: 40%;">Description</th> <th style="width: 40%;"></th> </tr> </thead> <tbody> <tr> <td>DDX[1:0]</td> <td>Data (B/W)</td> <td>LUT</td> </tr> <tr> <td rowspan="2">10</td> <td>0</td> <td>LUTBW(1->0)</td> </tr> <tr> <td>1</td> <td>LUTWB(0->1)</td> </tr> <tr> <td rowspan="2">11</td> <td>0</td> <td>LUTWB(0->0)</td> </tr> <tr> <td>1</td> <td>LUTBW(1->0)</td> </tr> </tbody> </table>				Bit 5-4	Description		DDX[1:0]	Data (Red/B/W)	LUT	00	00	LUTW	01	LUTB	10	LUTR	11	LUTR	01(default)	00	LUTB	01	LUT2	10	LUTR	11	LUTR	10	00	LUTR	01	LUTR	10	LUTW	11	LUTB	11	00	LUTR	01	LUTR	10	LUTB	11	LUTW	Bit 5-4	Description		DDX[1:0]	Data (B/W)	LUT	00	00	LUTWW0->0)	01	LUTBW(1->0)	10	LUTWB(0->1)	11	LUTBB(1->1)	01(default)	00	LUTBB(0->0)	01	LUTWB(1->0)	10	LUTBW(0->1)	11	LUTWW(1->1)	Bit 5-4	Description		DDX[1:0]	Data (B/W)	LUT	10	0	LUTBW(1->0)	1	LUTWB(0->1)	11	0	LUTWB(0->0)	1	LUTBW(1->0)
Bit 5-4	Description																																																																																				
DDX[1:0]	Data (Red/B/W)	LUT																																																																																			
00	00	LUTW																																																																																			
	01	LUTB																																																																																			
	10	LUTR																																																																																			
	11	LUTR																																																																																			
01(default)	00	LUTB																																																																																			
	01	LUT2																																																																																			
	10	LUTR																																																																																			
	11	LUTR																																																																																			
10	00	LUTR																																																																																			
	01	LUTR																																																																																			
	10	LUTW																																																																																			
	11	LUTB																																																																																			
11	00	LUTR																																																																																			
	01	LUTR																																																																																			
	10	LUTB																																																																																			
	11	LUTW																																																																																			
Bit 5-4	Description																																																																																				
DDX[1:0]	Data (B/W)	LUT																																																																																			
00	00	LUTWW0->0)																																																																																			
	01	LUTBW(1->0)																																																																																			
	10	LUTWB(0->1)																																																																																			
	11	LUTBB(1->1)																																																																																			
01(default)	00	LUTBB(0->0)																																																																																			
	01	LUTWB(1->0)																																																																																			
	10	LUTBW(0->1)																																																																																			
	11	LUTWW(1->1)																																																																																			
Bit 5-4	Description																																																																																				
DDX[1:0]	Data (B/W)	LUT																																																																																			
10	0	LUTBW(1->0)																																																																																			
	1	LUTWB(0->1)																																																																																			
11	0	LUTWB(0->0)																																																																																			
	1	LUTBW(1->0)																																																																																			
Restriction	This command only actives after R04H(PON) or R05H(PMES)																																																																																				

睿智皓天（成都）信息技术有限公司

File Name	Specification For HINK 2.13" EPD	Module Number	LCMEN2R13EFC1
Version	A0	Page Number	28 of 44

21) R51H (LPD): Lower Power Detection Register.

R51H	Bit										
Inst/Para	R/W	D/CX	D7	D6	D5	D4	D3	D2	D1	D0	Code
LPD	W	0	0	1	0	1	0	0	0	1	51H
1 st Parameter	R	1	GHD	SHD	SLD	SHRD	-	-	-	LPD	-

NOTE: “ - ” Don’ t care, can be set to VDD or GND level

Description	<p>-The command defines as: This command indicates the input power condition. Host can read this data to understand the battery’s condition. When LPD=’1’, system input power is normal. When LPD=’0’, system input power is lower (VDD<2.5v, which could be select in RE4H (LVSEL)). 1st Parameter:</p> <table border="1"> <thead> <tr> <th>Bit</th> <th>Name</th> <th>Description</th> </tr> </thead> <tbody> <tr> <td>0</td> <td>LPD</td> <td>0: Low power input 1: Normal status</td> </tr> <tr> <td>4</td> <td>SHRD</td> <td>0: Detect voltage < 90%VSHR 1: Normal status</td> </tr> <tr> <td>5</td> <td>SLD</td> <td>0: Detect voltage < 95%VSL 1: Normal status</td> </tr> <tr> <td>6</td> <td>SHD</td> <td>0: Detect voltage < 95%VSH 1: Normal status</td> </tr> <tr> <td>7</td> <td>GHD</td> <td>0: Detect voltage < 95%VGH 1: Normal status</td> </tr> </tbody> </table>	Bit	Name	Description	0	LPD	0: Low power input 1: Normal status	4	SHRD	0: Detect voltage < 90%VSHR 1: Normal status	5	SLD	0: Detect voltage < 95%VSL 1: Normal status	6	SHD	0: Detect voltage < 95%VSH 1: Normal status	7	GHD	0: Detect voltage < 95%VGH 1: Normal status
	Bit	Name	Description																
0	LPD	0: Low power input 1: Normal status																	
4	SHRD	0: Detect voltage < 90%VSHR 1: Normal status																	
5	SLD	0: Detect voltage < 95%VSL 1: Normal status																	
6	SHD	0: Detect voltage < 95%VSH 1: Normal status																	
7	GHD	0: Detect voltage < 95%VGH 1: Normal status																	
Restriction	<ul style="list-style-type: none"> - This command only actives when BUSY_N = “1”. - This command only actives after R04H(PON) /R05H(PMES) 																		

睿智皓天（成都）信息技术有限公司

File Name	Specification For HINK 2.13" EPD	Module Number	LCMEN2R13EFC1
Version	A0	Page Number	29 of 44

22)R60H (TCON): TCON setting

R60H	Bit										
Inst/Para	R/W	D/CX	D7	D6	D5	D4	D3	D2	D1	D0	Code
TCON	W	0	0	1	1	0	0	0	0	0	60H
1 st Parameter	W	1	S2G[3]	S2G[2]	S2G[1]	S2G[0]	G2S[3]	G2S[2]	G2S[1]	G2S[0]	22h

NOTE: " - " Don' t care, can be set to VDD or GND level

Description	- The command define Non-overlap period of gate and source as below: 1st Parameter:																																	
	<table border="1"> <thead> <tr> <th>Bit</th> <th>Period</th> </tr> </thead> <tbody> <tr><td>S2G[3:0]/G2S[3:0]</td><td>0000: 4 clock</td></tr> <tr><td></td><td>0001: 8 clock</td></tr> <tr><td></td><td>0010: 12 clock (default)</td></tr> <tr><td></td><td>0011:16 clock</td></tr> <tr><td></td><td>0100: 20 clock</td></tr> <tr><td></td><td>0101: 24 clock</td></tr> <tr><td></td><td>0110: 28 clock</td></tr> <tr><td></td><td>0111: 32 clock</td></tr> <tr><td></td><td>1000: 36 clock</td></tr> <tr><td></td><td>1001: 40 clock</td></tr> <tr><td></td><td>1010: 44 clock</td></tr> <tr><td></td><td>1011: 48 clock</td></tr> <tr><td></td><td>1100: 52 clock</td></tr> <tr><td></td><td>1101: 56 clock</td></tr> <tr><td></td><td>1110: 60 clock</td></tr> <tr><td></td><td>1111: 64 clock</td></tr> </tbody> </table>	Bit	Period	S2G[3:0]/G2S[3:0]	0000: 4 clock		0001: 8 clock		0010: 12 clock (default)		0011:16 clock		0100: 20 clock		0101: 24 clock		0110: 28 clock		0111: 32 clock		1000: 36 clock		1001: 40 clock		1010: 44 clock		1011: 48 clock		1100: 52 clock		1101: 56 clock		1110: 60 clock	
Bit	Period																																	
S2G[3:0]/G2S[3:0]	0000: 4 clock																																	
	0001: 8 clock																																	
	0010: 12 clock (default)																																	
	0011:16 clock																																	
	0100: 20 clock																																	
	0101: 24 clock																																	
	0110: 28 clock																																	
	0111: 32 clock																																	
	1000: 36 clock																																	
	1001: 40 clock																																	
	1010: 44 clock																																	
	1011: 48 clock																																	
	1100: 52 clock																																	
	1101: 56 clock																																	
	1110: 60 clock																																	
	1111: 64 clock																																	
Restriction	<p>Period=650ns</p>																																	

睿智皓天（成都）信息技术有限公司

File Name	Specification For HINK 2.13" EPD	Module Number	LCMEN2R13EFC1
Version	A0	Page Number	30 of 44

23) R61H (TRES): Resolution setting

R61H	Bit										
Inst/Para	R/W	D/CX	D7	D6	D5	D4	D3	D2	D1	D0	Code
TRES	W	0	0	1	1	0	0	0	0	1	61H
1 st Parameter	W	1	HRES[7]	HRES[6]	HRES[5]	HRES[4]	HRES[3]	-	-	-	00h
2 nd Parameter	W	1								VRES[8]	00h
3 th Parameter	W	1	VRES[7]	VRES[6]	VRES[5]	VRES[4]	VRES[3]	VRES[2]	VRES[1]	VRES[0]	00h

NOTE: " - " Don' t care, can be set to VDD or GND level

Description	<p>-The command define as follows: When using register: Horizontal display resolution(source) = HRES Vertical display resolution(gate) = VRES Channel disable calculation: GD : First G active = G0; LAST active GD= first active +VRES[7:0] -1 SD : First active channel: =S0 ; LAST active SD= first active +HRES[7:3]*8-1 EX :128X240 GD: First G active = G0 LAST active GD= 0+240-1= 239; (G239) SD : First active channel: =S0 LAST active SD=0+16*8-1=127; (S127)</p>
Restriction	

24)R65H (GSST): Gate/Source Start Setting Register

R65H	Bit										
Inst/Para	R/W	D/CX	D7	D6	D5	D4	D3	D2	D1	D0	Code
GSST	W	0	0	1	1	0	0	1	0	1	65H
1 st Parameter	W	1	S_start[7]	S_start[6]	S_start[5]	S_start[4]	S_start[3]	--	--	--	00h
2 nd Parameter	W	1				gscan				G_start[8]	00h
3 rd Parameter	W	1	G_start[7]	G_start[6]	G_start[6]	G_start[4]	G_start[3]	G_start[2]	G_start[1]	G_start[0]	00h

NOTE: " - " Don' t care, can be set to VDD or GND level

Description	<p>-The command define as follows: 1.S_Start [7:3] describe which source output line is the first date line 2.G_Start[7:0] describe which gate line is the first scan line 3. gscan :Gate scan select 0: Normal scan 1: Cascade type 2 scan</p>
Restriction	S_Start should be the multiple of 8

睿智皓天（成都）信息技术有限公司

File Name	Specification For HINK 2.13" EPD	Module Number	LCMEN2R13EFC1
Version	A0	Page Number	31 of 44

25) RE3H (PWS): Power Saving Register

RE3H	Bit										
Inst/Para	R/W	D/CX	D7	D6	D5	D4	D3	D2	D1	D0	Code
PWS	W	0	1	1	1	0	0	0	1	1	E3H
1 st Parameter	W	1	VCOM_W[3:0]				SD_W[3:0]				00h

NOTE: “ - ” Don’ t care, can be set to VDD or GND level

Description	<p>- This command is set for saving power during refreshing period. If the output voltage of VCOM / Source is from negative to positive or from positive to negative, the power saving mechanism will be activated. The active period width is defined by the following two parameters.</p> <p>VCOM W: VCOM power saving width (unit = line period)</p> <p>SD W: Source power saving width (unit = 660nS)</p>
Restriction	

File Name	Specification For HINK 2.13" EPD	Module Number	LCMEN2R13EFC1
Version	A0	Page Number	32 of 44

8 . HOST INTERFACES

8.1 “3-Wire” Serial Port Interface

E0213A285 use the 3-wire serial port as communication interface for all the function and command setting. 3-Wire communication can be bi-directional controlled by the “R/W” bit in address field. 3-Wire engine act as a “slave mode” for all the time, and will not issue any command to the 3-Wire bus itself. Under read mode, 3-Wire engine will return the data during “Data phase”. The returned data should be latched at the rising edge of SCL by external controller. Data in the “Hi-Z phase” will be ignored by 3-Wire engine during write operation, and should be ignored during read operation also. During read operation, external controller should float SDA pin under “Hi-Z phase” and “Data phase”.

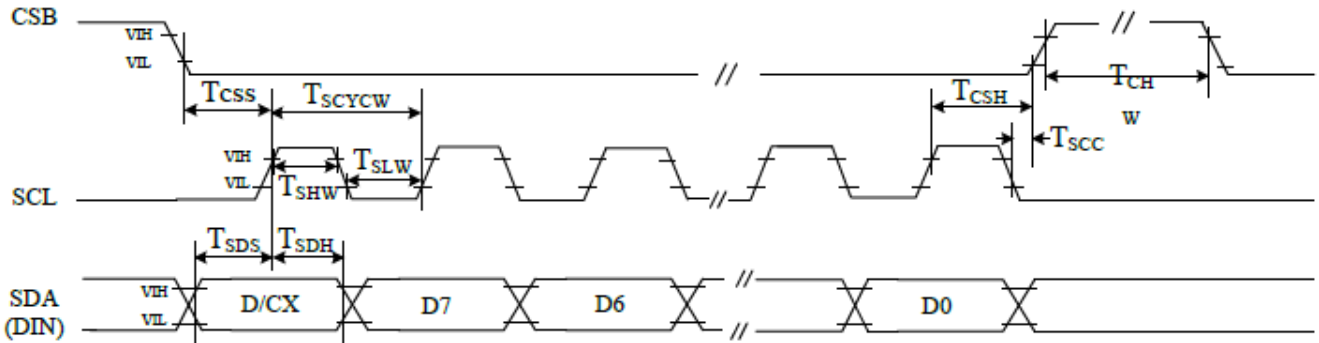

Figure 8-1 3 pin serial interface characteristics (write mode)

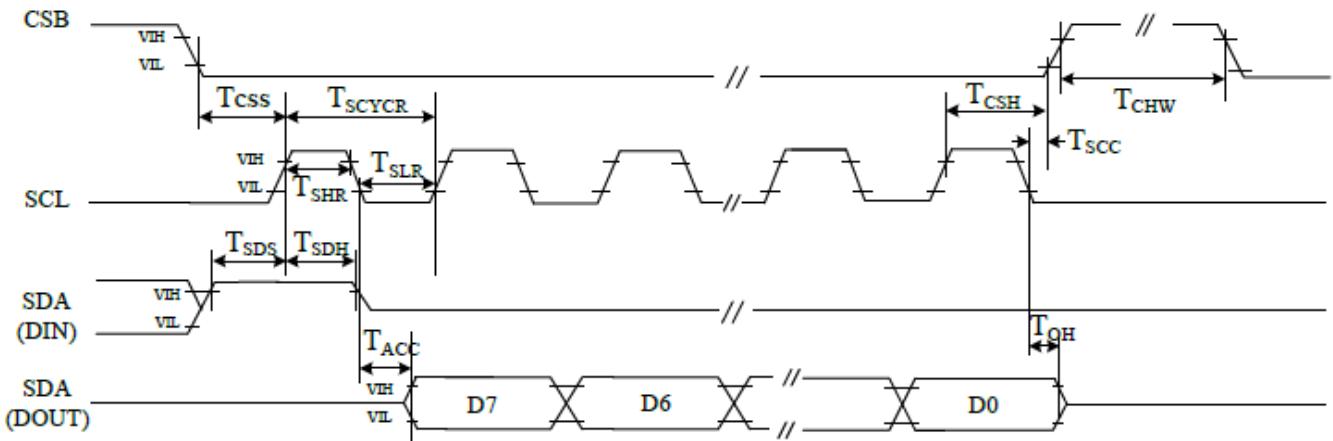
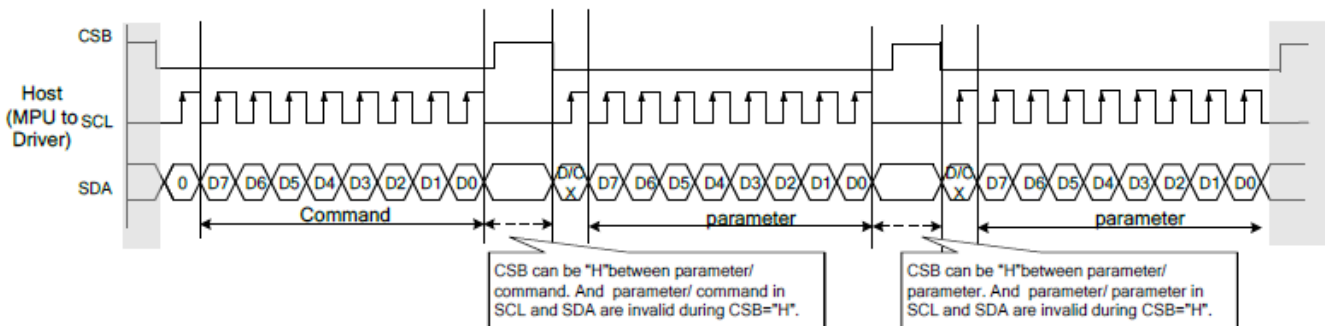

Figure 8-2 3 pin serial interface characteristics (read mode)



睿智皓天（成都）信息技术有限公司

File Name	Specification For HINK 2.13" EPD	Module Number	LCMEN2R13EFC1
Version	A0	Page Number	33 of 44

8.1 "4-Wire" Serial Port Interface

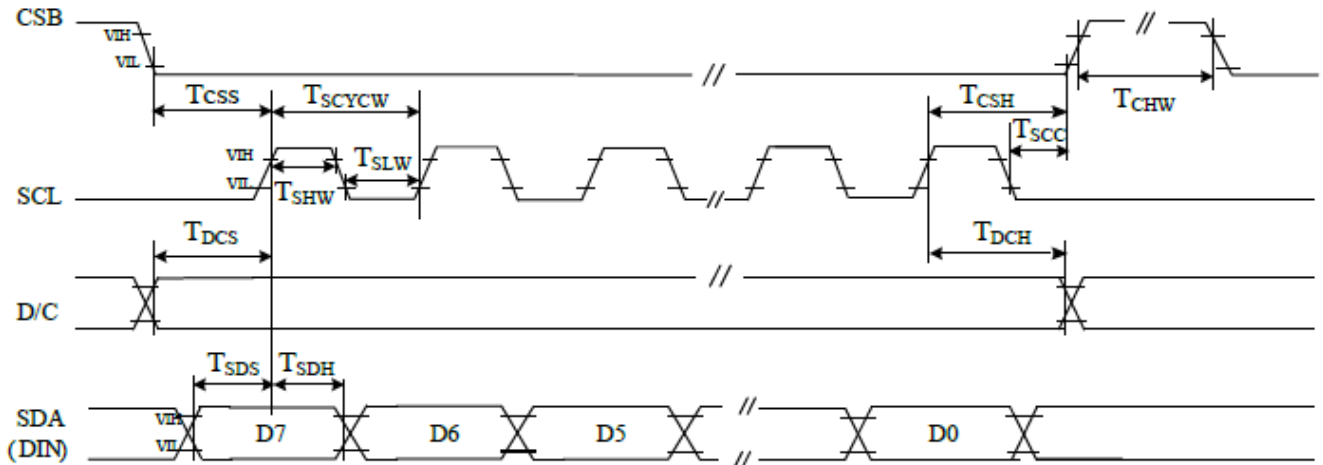

Figure 8-3 4 pin serial interface characteristics (write mode)

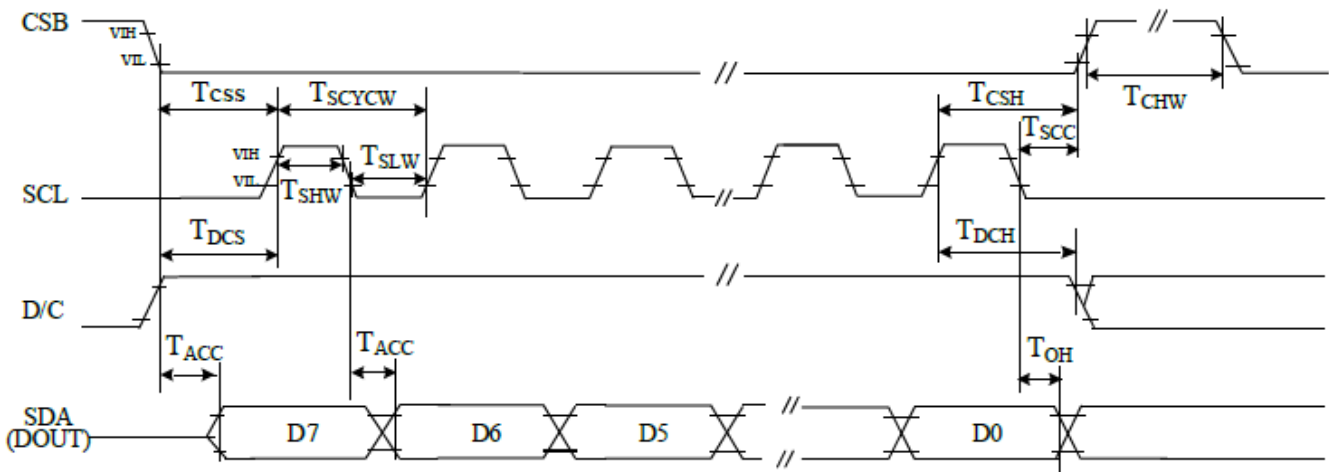
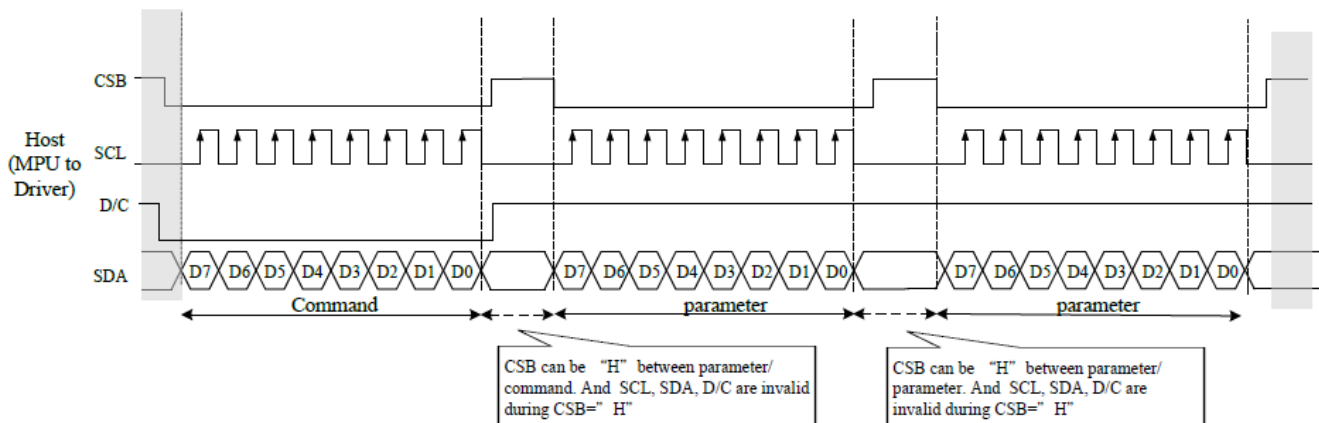

Figure 8-4 4 pin serial interface characteristics (read mode)



睿智皓天（成都）信息技术有限公司

File Name	Specification For HINK 2.13" EPD	Module Number	LCMEN2R13EFC1
Version	A0	Page Number	34 of 44

9. Power ON/OFF Sequence

In order to prevent IC fail in power on resetting, the power sequence must be followed as below.

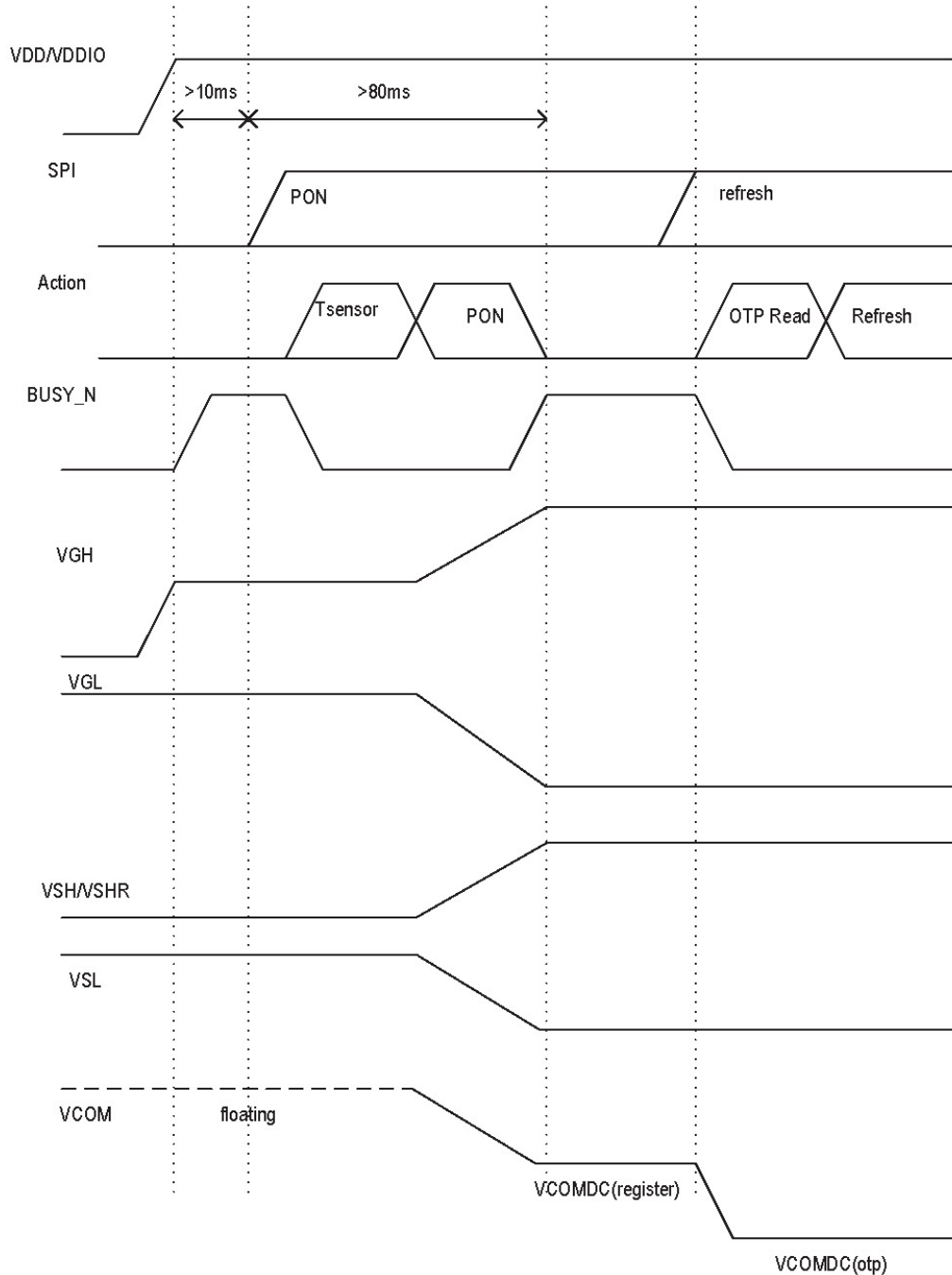

Power on sequence

Figure 9-1: Power on sequence

睿智皓天（成都）信息技术有限公司

File Name	Specification For HINK 2.13 ^{WISEVAST} EPD	Module Number	LCMEN2R13EFC1
Version	A0	Page Number	35 of 44

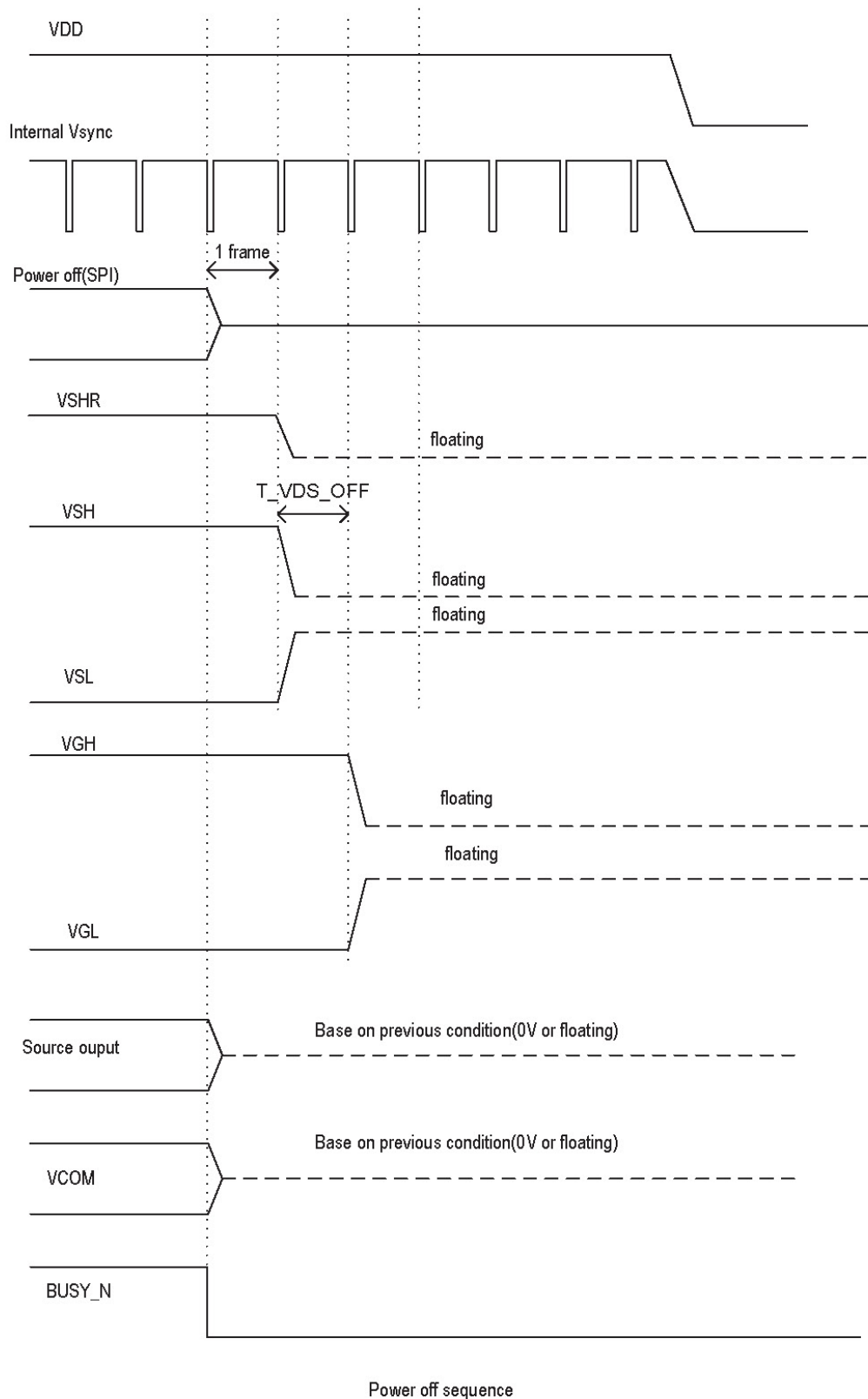

Figure 9-2: Power off sequence

睿智皓天（成都）信息技术有限公司

File Name	Specification For HINK 2.13" EPD	Module Number	LCMEN2R13EFC1
Version	A0	Page Number	36 of 44

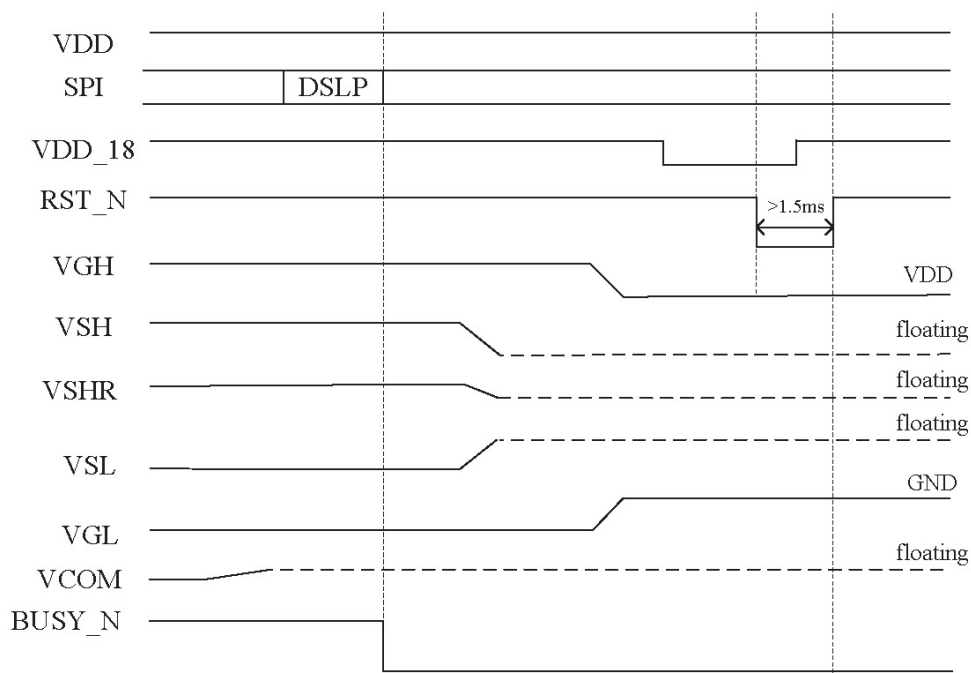

Figure 9-3: DSLP sequence

10. Reference Circuit

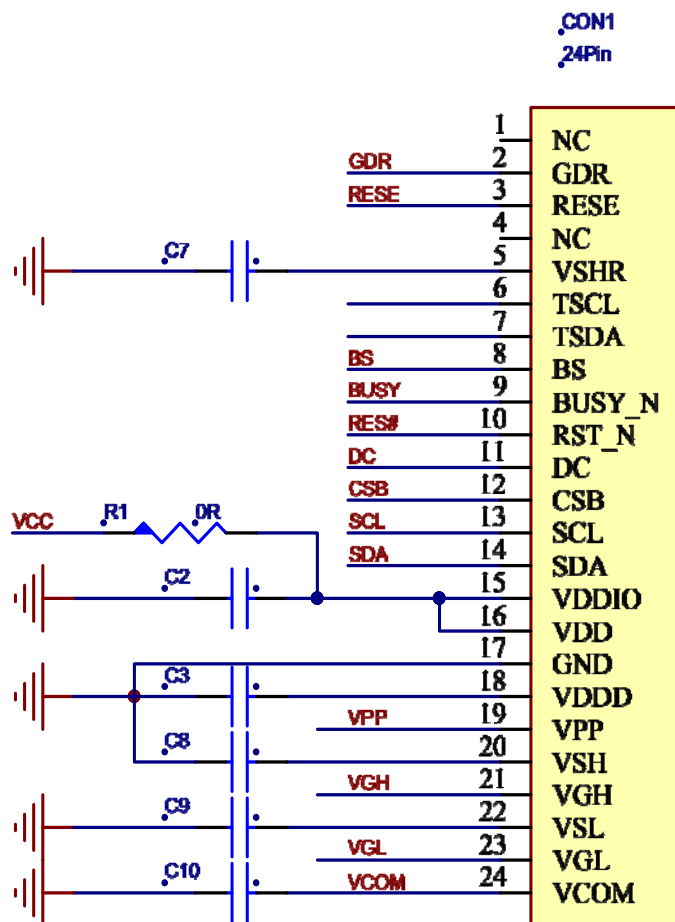

Figure 10-1

睿智皓天（成都）信息技术有限公司

File Name	Specification For HINK 2.13" EPD	Module Number	LCMEN2R13EFC1
Version	A0	Page Number	37 of 44

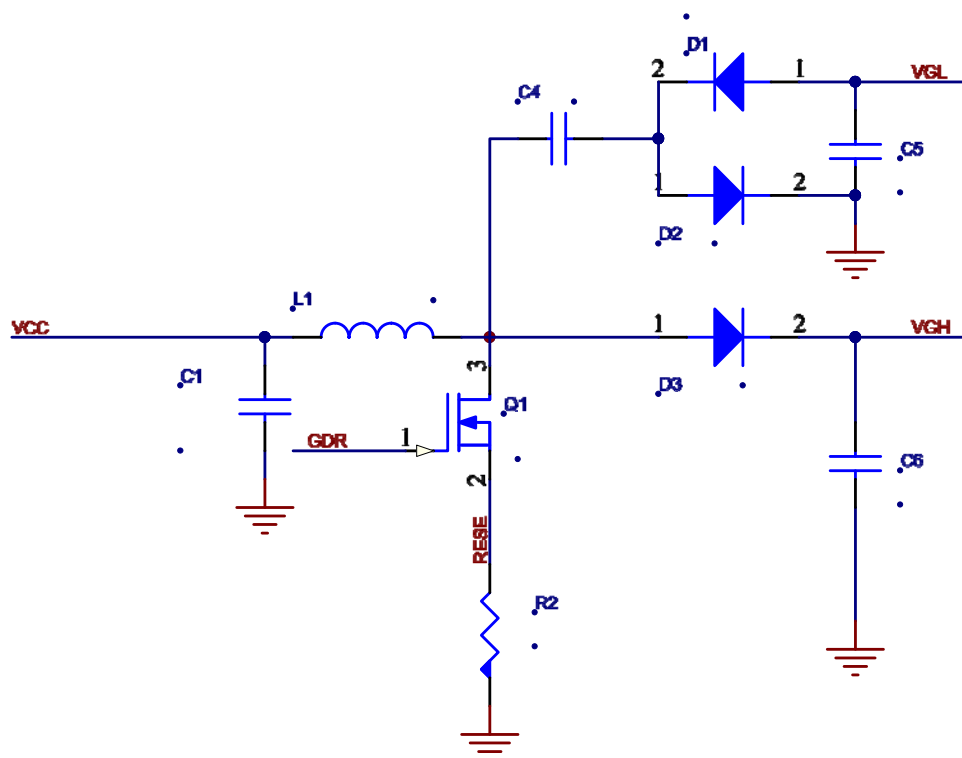

Figure 10-2

Part Name	Value /requirement/Reference Part
C1—C3	1uF/0603;X5R;Voltage Rating: 25V
C4-C9	1uF/0603;X5R;Voltage Rating: 50V
C10	0.47uF/0603; X5R;Voltage Rating: 25V
D1—D3	MBR0530 1) Reverse DC voltage $\geq 30V$ 2) Forward current $\geq 500mA$ 3) Forward voltage $\leq 430mV$
R2	2.2 Ω /0603: 1% variation
Q1	NMOS:Si1308EDL、Si1304BDL 1) Drain-Source breakdown voltage $\geq 30V$ 2) $V_{gs(th)} = 0.9 (Typ) , 1.3V (Max)$ 3) $R_{ds(on)} \leq 2.1 \Omega @ V_{gs}=2.5V$
L1	47UH/NRH3010T470MN $I_o = 500 (Max)$
CON24Pin	0.5mm ZIF Socket 24Pins,0.5mm pitch

睿智皓天（成都）信息技术有限公司

File Name	Specification For HINK 2.13" EPD	Module Number	LCMEN2R13EFC1
Version	A0	Page Number	38 of 44

11. ABSOLUTE MAXIMUM RATINGS

Table 11-1: Maximum Ratings

Symbol	Parameter	Rating	Unit	Humidity	Unit	Note
V _{DD}	Logic supply voltage	-0.3 to +6.0	V	-	-	
T _{OPR}	Operation temperature range	0 to 50	°C	35 to70	%	Note 11-1
T _{tg}	Transportation temperature range	-25 to 60	°C	-	%	Note11-2
T _{stg}	Storage condition	0 to 40	°C	35 to70	%	Maximum storage time: 5 years

Note 11-1: Maximum ratings are those values beyond which damages to the device may occur. Functional operation should be restricted to the limits in the Electrical Characteristics chapter.

Note11-2: T_{tg} is the transportation condition, the transport time is within 10 days for -25°C~0°C or 50°C~60°C

12. DC CHARACTERISTICS

The following specifications apply for: V_{SS}=0V, V_{DD}=3.3V, T_{OPR}=25°C.

Table 12-1: DC Characteristics

Symbol	Parameter	Condition	Min.	Typ.	Max.	Unit
V _{DD}	Digital/Analog supply voltage	-	2.5	3.3	3.6	V
V _{IH}	High level input voltage	Digital input pins	0.7xV _{IO}	-	V _{IO}	V
V _{IL}	Low level input voltage	Digital input pins	GND	-	0.3xV _{DD}	V
V _{OH}	High level output voltage	I _{OH} = 400uA	V _{IO} -0.4	-	-	V
V _{OL}	Low level output voltage	I _{OL} = -400uA	GND	-	GND+0.4	V
I _{update}	Module operating current	-	-	3	-	mA
I _{sleep}	Deep sleep mode	V _{DD} =3.3V	-	-	0.3	uA

- The Typical power consumption is measured using associated 25°C waveform with following pattern transition: from horizontal scan pattern to vertical scan pattern. (Note 12-1)
- The listed electrical/optical characteristics are only guaranteed under the controller & waveform provided by XingTai.
- V_{com} value will be OTP before in factory or present on the label sticker.

Note 12-1

The Typical power consumption

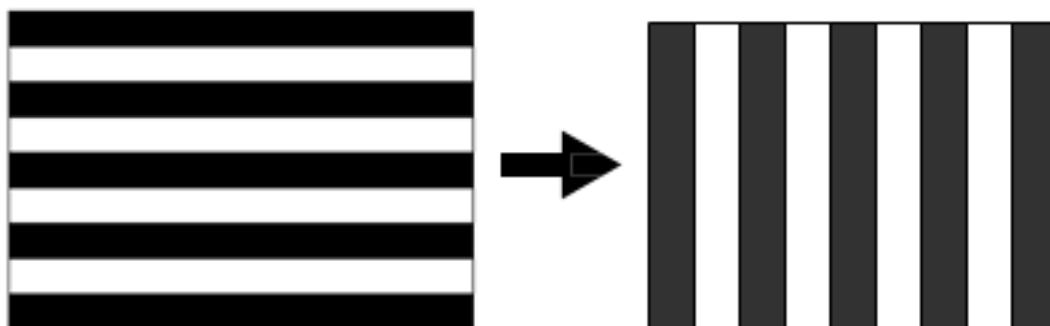

睿智皓天（成都）信息技术有限公司

File Name	Specification For HINK 2.13" EPD	Module Number	LCMEN2R13EFC1
Version	A0	Page Number	39 of 44

13. AC CHARACTERISTICS

Parameter	Symbol	Min.	Typ.	Max.	Unit	Condition
CSB	TCSS	60			ns	Chip select setup time
	TCSH	65			ns	Chip select hold time
	TSCC	20			ns	Chip select CSB setup time
	TCHW	40			ns	Chip select setup time
SCL	TSCYCW	100			ns	Serial clock cycle (Write)
	TSHW	35			ns	SCL "H" pulse width (Write)
	TSLW	35			ns	SCL "L" pulse width (Write)
	TSCYCR	150			ns	Serial clock cycle (Read)
	TSHR	60			ns	SCL "H" pulse width (Read)
	TSLR	60			ns	SCL "L" pulse width (Read)
SDA (DIN) (DOUT)	TSDS	30			ns	Data setup time
	TSDH	30			ns	Data hold time
	TACC			50	ns	Access time
	TOH	15			ns	Output disable time
D/C	TDCS	20			ns	DC setup time
	TDCH	20			ns	DC hold time

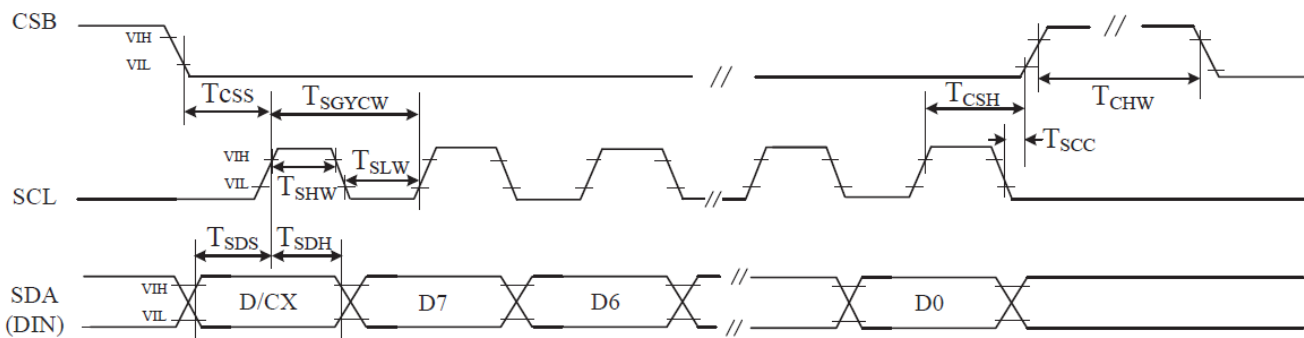

3 pin serial interface characteristics (write mode)

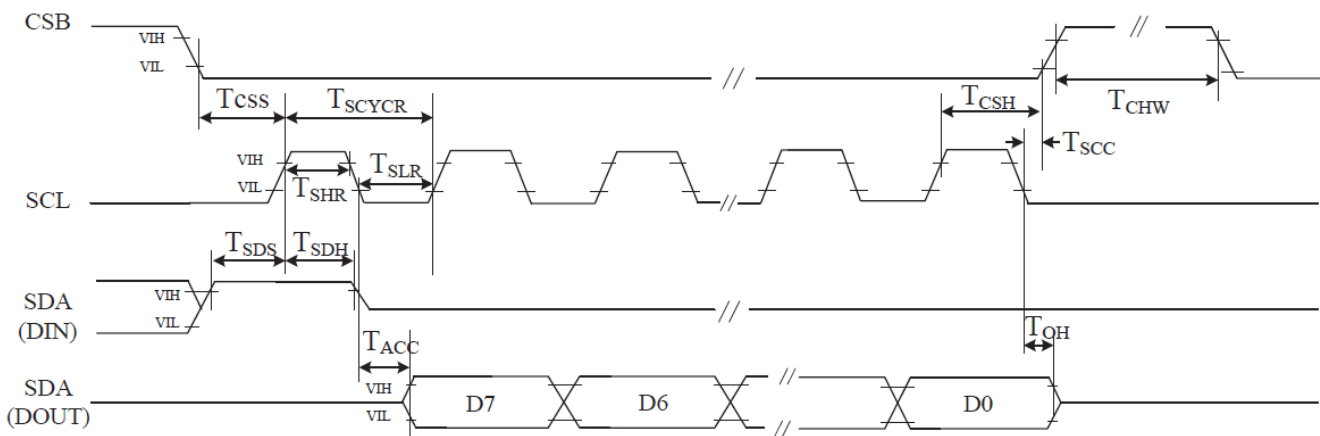

3 pin serial interface characteristics (read mode)

睿智皓天（成都）信息技术有限公司

File Name	Specification For HINK 2.13" EPD	Module Number	LCMEN2R13EFC1
Version	A0	Page Number	40 of 44

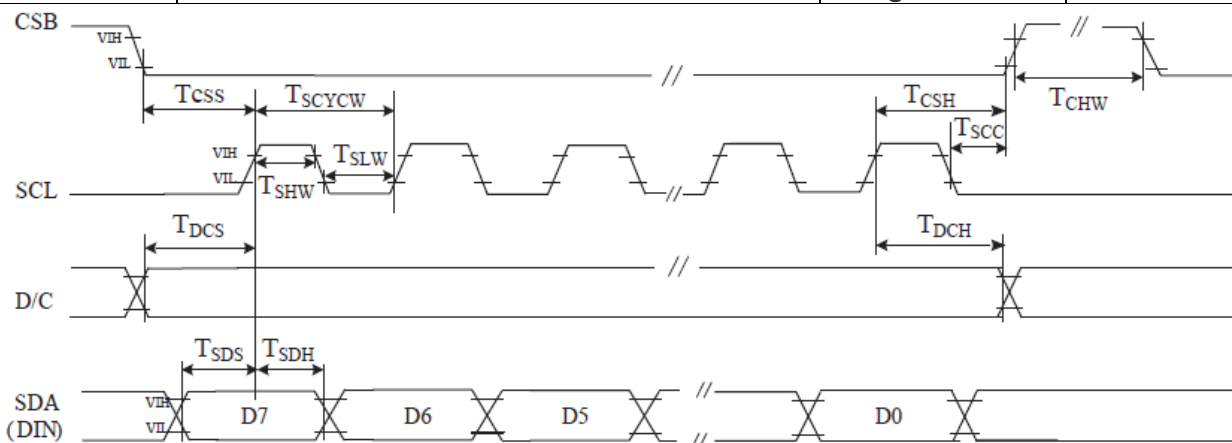

4 pin serial interface characteristics(write mode)

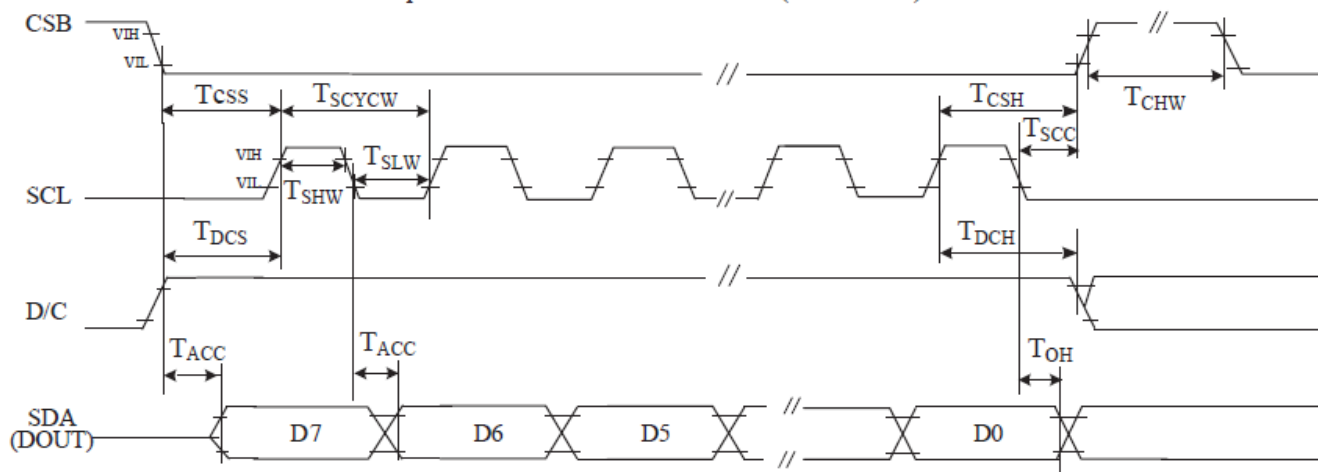

4 pin serial interface characteristics(read mode)

Figure 13-1: SPI interface interface timing

睿智皓天（成都）信息技术有限公司

File Name	Specification For HINK 2.13" EPD	Module Number	LCMEN2R13EFC1
Version	A0	Page Number	41 of 44

14. Power Consumption

Parameter	Symbol	Conditions	TYP	Max	Unit	Remark
Panel power consumption during update	-	25°C	-	20	mAs	-
Deep sleep mode	-	25°C	-	3	uA	-

mAs=update average current× update time

15. Optical characteristics

15.1 Specifications

Measurements are made with that the illumination is under an angle of 45 degrees, the detection is perpendicular unless otherwise specified.

T=25±2°C, VDD=3.3V

SYMBOL	PARAMETER	CONDITIONS	MIN	TYP.	MAX	UNIT	Note
R	Reflectance	White	30	35	-	%	Note 15-1
Gn	2Grey Level	-	-	$KS+(WS-KS) \times n(m-1)$	-	L*	-
CR	Contrast Ratio	-	-	10	-	-	-
KS	Black State L* value	-	-	18	-	-	Note 15-1
	Black State a* value	-	-	0.2	-	-	Note 15-1
WS	White State L* value	-	-	67	-	-	Note 15-1
Panel	Image Update	Storage and transportation	-	Update the white screen	-	-	-
	Update Time	Operation	-	Suggest Updated once a day	-	-	-

WS : White state, KS : Black State,

Note 15-1 : Luminance meter : i - One Pro Spectrophotometer

Note 15-2: We guarantee display quality from 0°C~30°C generally, If operation ambient temperature from 0°C~50°C, will offer special waveform by Xingtai.

睿智皓天（成都）信息技术有限公司

File Name	Specification For HINK 2.13" EPD	Module Number	LCMEN2R13EFC1
Version	A0	Page Number	42 of 44

15. 2 Definition of contrast ratio

The contrast ratio (CR) is the ratio between the reflectance in a full white area (Rl) and the reflectance in a dark area (Rd):

$$CR = Rl/Rd$$

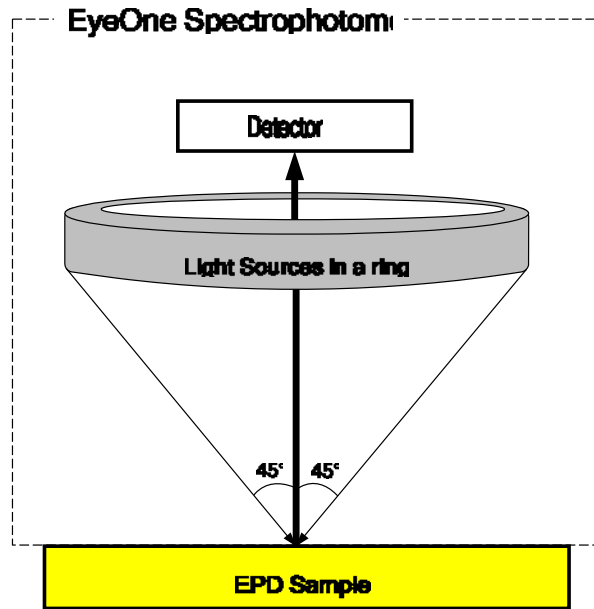

15. 3 Reflection Ratio

The reflection ratio is expressed as:

$$R = \text{Reflectance Factor}_{\text{white board}} \times (L_{\text{center}} / L_{\text{white board}})$$

L_{center} is the luminance measured at center in a white area ($R=G=B=1$). $L_{\text{white board}}$ is the luminance of a standard white board. Both are measured with equivalent illumination source. The viewing angle shall be no more than 2 degrees.

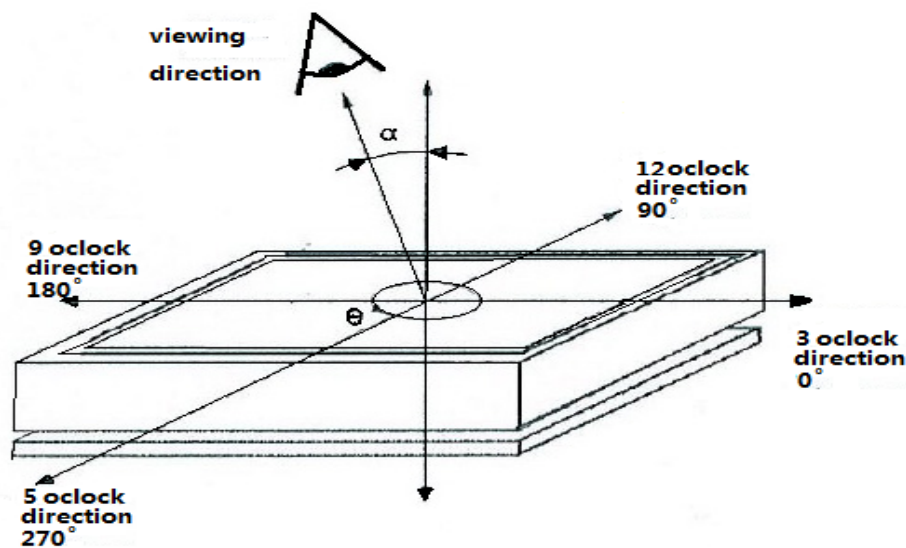

睿智皓天（成都）信息技术有限公司

File Name	Specification For HINK 2.13" EPD	Module Number	LCMEN2R13EFC1
Version	A0	Page Number	43 of 44

16. HANDLING, SAFETY AND ENVIROMENTAL REQUIREMENTS

WARNING

The display module should be kept flat or fixed to a rigid, curved support with limited bending along the long axis. It should not be used for continual flexing and bending. Handle with care. Should the display break do not touch any material that leaks out. In case of contact with the leaked material then wash with water and soap.

CAUTION

The display module should not be exposed to harmful gases, such as acid and alkali gases, which corrode electronic components.

Disassembling the display module can cause permanent damage and invalidate the warranty agreements.

IPA solvent can only be applied on active area and the back of a glass. For the rest part, it is not allowed.

Observe general precautions that are common to handling delicate electronic components. The glass can break and front surfaces can easily be damaged . Moreover the display is sensitive to static electricity and other rough environmental conditions.

Mounting Precautions

(1) It's recommended that you consider the mounting structure so that uneven force (ex. Twisted stress) is not applied to the module.

(2) It's recommended that you attach a transparent protective plate to the surface in order to protect the EPD. Transparent protective plate should have sufficient strength in order to resist external force.

(3) You should adopt radiation structure to satisfy the temperature specification.

(4) Acetic acid type and chlorine type materials for the cover case are not desirable because the former generates corrosive gas of attacking the PS at high temperature and the latter causes circuit break by electro-chemical reaction.

(5) Do not touch, push or rub the exposed PS with glass, tweezers or anything harder than HB pencil lead. And please do not rub with dust clothes with chemical treatment. Do not touch the surface of PS for bare hand or greasy cloth. (Some cosmetics deteriorate the PS)

(6) When the surface becomes dusty, please wipe gently with absorbent cotton or other soft materials like chamois soaks with petroleum benzene. Normal-hexane is recommended for cleaning the adhesives used to attach the PS. Do not use acetone, toluene and alcohol because they cause chemical damage to the PS.

(7) Wipe off saliva or water drops as soon as possible. Their long time contact with PS causes deformations and color fading.

睿智皓天（成都）信息技术有限公司

File Name	Specification For HINK 2.13" EPD	Module Number	LCMEN2R13EFC1
Version	A0	Page Number	44 of 44

Data sheet status

Product specification	The data sheet contains final product specifications.
-----------------------	---

Limiting values

Limiting values given are in accordance with the Absolute Maximum Rating System (IEC 134). Stress above one or more of the limiting values may cause permanent damage to the device. These are stress ratings only and operation of the device at these or any other conditions above those given in the Characteristics sections of the specification is not implied. Exposure to limiting values for extended periods may affect device reliability.

Application information

Where application information is given, it is advisory and does not form part of the specification.

Product Environmental certification

ROHS

REMARK

All The specifications listed in this document are guaranteed for module only. Post-assembled operation or component(s) may impact module performance or cause unexpected effect or damage and therefore listed specifications is not warranted after any Post-assembled operation.

睿智皓天（成都）信息技术有限公司

File Name	Specification For HINK 2.13" EPD	Module Number	LCMEN2R13EFC1
Version	A0	Page Number	45 of 44

17. Reliability test

17.1 Reliability Test Items

	TEST	CONDITION	REMARK
1	High-Temperature Operation	T=40°C, RH=35%RH, For 240Hr	
2	Low-Temperature Operation	T = 0°C for 240 hrs	
3	High-Temperature Storage	T=60°C RH=35%RH For 240Hr	Test in white pattern
4	Low-Temperature Storage	T = -25°C for 240 hrs	Test in white pattern
5	High Temperature, High-Humidity Operation	T=40°C, RH=90%RH, For 168Hr	
6	High Temperature, High-Humidity Storage	T=60°C, RH=80%RH, For 240Hr	Test in white pattern
7	Temperature Cycle	-25°C(30min)~70°C(30min), 100 Cycle	Test in white pattern
8	Package Vibration	1.04G, Frequency : 20~200Hz Direction : X,Y,Z Duration: 30 minutes in each direction	Full packed for shipment
9	Package Drop Impact	Drop from height of 100 cm on Concrete surface Drop sequence: 1 corner, 3edges, 6face One drop for each.	Full packed for shipment
10	UV exposure Resistance	765 W/m ² for 168hrs, 40°C	
11	Electrostatic discharge	Machine model: +/-250V, 0Ω, 200pF	

Actual EMC level to be measured on customer application.

Note1: Stay white pattern for storage and non-operation test.

Note2: Operation is black/white pattern, hold time is 150S.

Note3: The function, appearance should meet the requirements of the test before and after the test.

Note4: Keep testing after 2 hours placing at 20°C-25°C.

17.2 Product life time

The EPD Module is designed for a 5-year life-time with 25 °C/50%RH operation assumption. Reliability estimation testing with accelerated life-time theory would be demonstrated to provide confidence of EPD lifetime.

17.3 Product warranty

Warranty conditions have to be negotiated between Xingtai and individual customers.

Xingtai provides 12+1(one month delivery time) months warranty for all products which are purchased from Xingtai.

睿智皓天（成都）信息技术有限公司

File Name	Specification For HINK 2.13" EPD	Module Number	LCMEN2R13EFC1
Version	A0	Page Number	46 of 42

18. Block Diagram

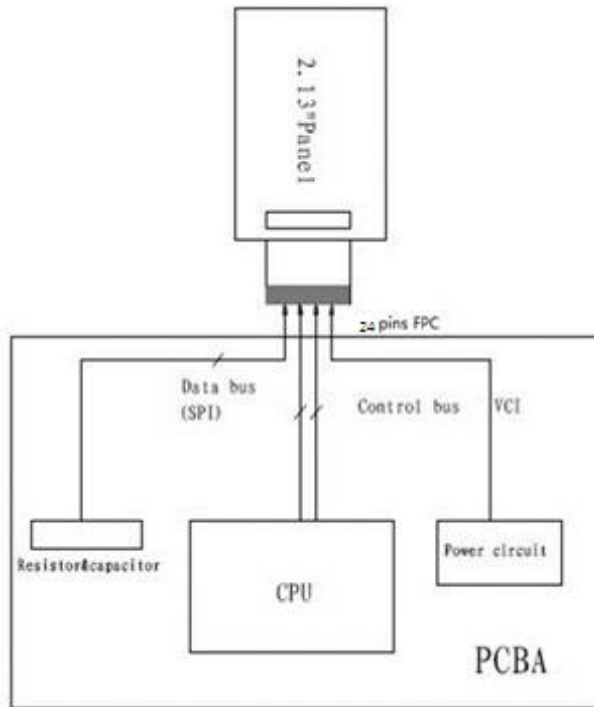

19. PartA/PartB specification

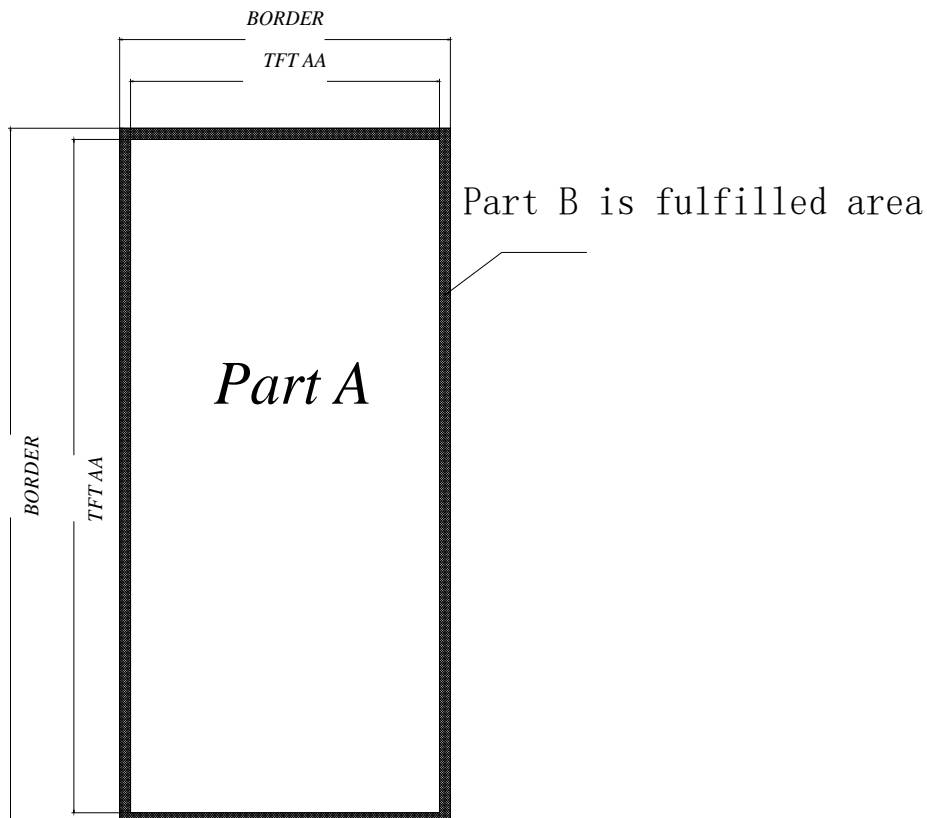

睿智皓天（成都）信息技术有限公司

File Name	Specification For HINK 2.13" EPD	Module Number	LCMEN2R13EFC1
Version	A0	Page Number	47 of 42

20. Point and line standard

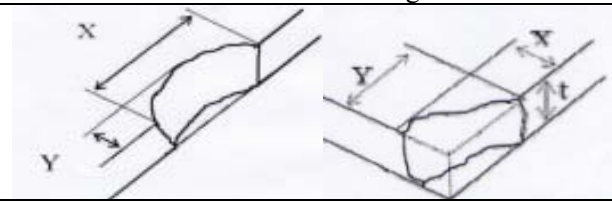
Shipment Inspection Standard						
Equipment: Electrical test fixture, Point gauge						
Outline dimension	29.2(H)×59.2(V)×0.9(D)	Unit: mm	Part-A	Active area	Part-B	Border area
Environment	Temperature	Humidity	Illuminance	Distance	Time	Angle
	19°C~25°C	55%±5%RH	800~1300Lux	300mm	35Sec	
Defect type	Inspection method	Standard		Part-A	Part-B	
Spot	Electric Display	D≤0.25mm		Ignore	Ignore	
		0.25mm<D≤0.4mm		N≤4	Ignore	
		D>0.4mm		Not Allow	Ignore	
Display unwork	Electric Display	Not Allow		Not Allow	Ignore	
Display error	Electric Display	Not Allow		Not Allow	Ignore	
Scratch or line defect(include dirt)	Visual/Film card	L≤2mm,W≤0.2mm		Ignore	Ignore	
		2.0mm<L≤5.0mm,0.2<W≤0.3mm,		N≤2	Ignore	
		L>5mm,W>0.3mm		Not Allow	Ignore	
PS Bubble	Visual/Film card	D≤0.2mm		Ignore	Ignore	
		0.2mm≤D≤0.35mm		N≤4	Ignore	
		D>0.35 mm		Not Allow	Ignore	
Side Fragment	Visual/Film card	X≤6mm,Y≤0.4mm, Do not affect the electrode circuit (Edge chipping)				
		X≤1mm,Y≤1mm, Do not affect the electrode circuit((Corner chipping)				
		Ignore				
						
Remark	1. Appearance defect should not cause electrical defects;					
	2. Appearance defects should not cause dimensional accuracy problems					
	L=long W=wide D=point size N=Defects NO					

睿智皓天（成都）信息技术有限公司

File Name	Specification For HINK 2.13" EPD	Module Number	LCMEN2R13EFC1
Version	A0	Page Number	48 of 42

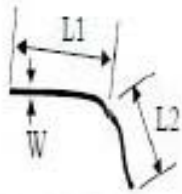

$$L = L1 + L2$$

Line Defect

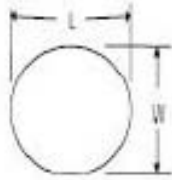

$$D = (L + W) / 2$$

Spot Defect

L=long W=wide D=point size

睿智皓天（成都）信息技术有限公司

File Name	Specification For HINK 2.13" EPD	Module Number	LCMEN2R13EFC1
Version	A0	Page Number	49 of 42

21.Barcode

21.1 label appearance



ABBBBBBBCC
DDDEEEFGGG

21.2 QR scanned information (Total 28 code number+ 2 blank spaces)

A BBBBBBBB CC □ DDD EEE F GGG □ H III JJ KK
① ② ③ ④ ⑤ ⑥ ⑦ ⑧ ⑨ ⑩ ⑪

- ① A——The factory code
- ② BBBBBBBB——Module name of EPD
- ③ CC——Production line
- ④ DDD——Date of production
- ⑤ EEE——Production lot
- ⑥ F——Separator
- ⑦ GGG——FPL Lot
- ⑧ H——Product status
- ⑨ III——TFT、PS、EC.
- ⑩ JJ——IC
- ⑪ KK——Serial NO.
- blank spaces

睿智皓天（成都）信息技术有限公司

File Name	Specification For HINK 2.13" EPD	Module Number	LCMEN2R13EFC1
Version	A0	Page Number	50 of 42

22. Packing

Packing Spec

Sheet No :

WISEVAST	Part No	LCMEN2R13EFC1	DATE	2021. 3. 23	VER		Page	A0
----------	---------	---------------	------	-------------	-----	--	------	----

一, Package Type: Box

Box No	Holitech shipment box
Box size	515*322*170
Containment	450 PCS

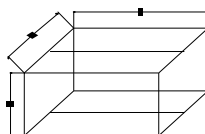

PRODUCT DRAWING

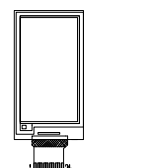

二, Inside package type: Plastic Tray
Tray unit: mm

Plastic Tray	465*280*15	13 pcs
Anti-static foil bags	700*530*0.1	1 pcs
EPE (inside)	405.5*250.4*2	12 pcs
EPE (Up-Down)	485*145*10	2 pcs
EPE (Left-Right)	285*480*10	2 pcs
EPE (Front-back)	310*145*10	2 pcs
Chip board	500*306*5	2 pcs
Quantity/tray	15 pcs	
Tray number/sheet	15+1 Sheets	
Box	1	

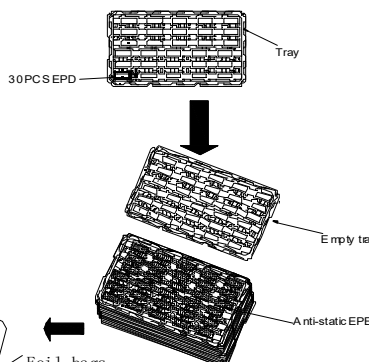

Step 1:

Material: Tray, EPE
Put the product in to the tray and keep the display side up. Then put anti-static EPE in to each holes.

Step 2,

1), Must keep the angle 180 degree placed between the neighboring Plastic trays.
2), There are 15 layers product, total 30*15=450 pcs.
3), An empty Plastic tray intersects put on the top of the plastic trays.

Step 5,

1), Seal the box with adhesive tapes .
2), Paste the lable onto the exterior box, and the lable can't cover the safety , transfer and RoSH sign.

Step 3,

1), In each case, put 2 bags of desiccant. then seal the trays with adhesive tapes.
2), Put the trays into foil bags.
3), heat seal the foil bags.

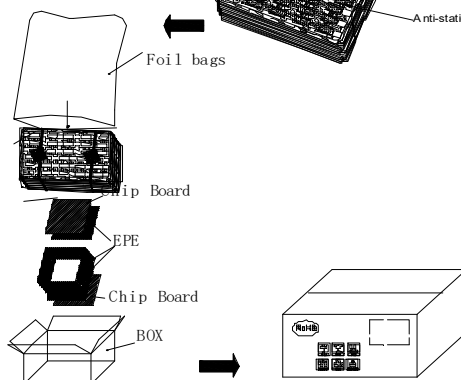

Step 4,

1), First put a chip board on the bottom of the box, then placed the down EPE, the left - right and front -back EPE.
2), Placed the sealed products into the box.
3), The last placed the up EPE on the top of the trays, and place a chip board on it.

Design	X. Z. P	Approve	Daisy	Confirm	H.Z.P
Date	2021. 3. 23	Date	2021. 3. 23	Date	2021. 3. 23

1-1