

N014 ENDF/B-VIII.0 NJOY12.111 293.6K

Principal cross sections

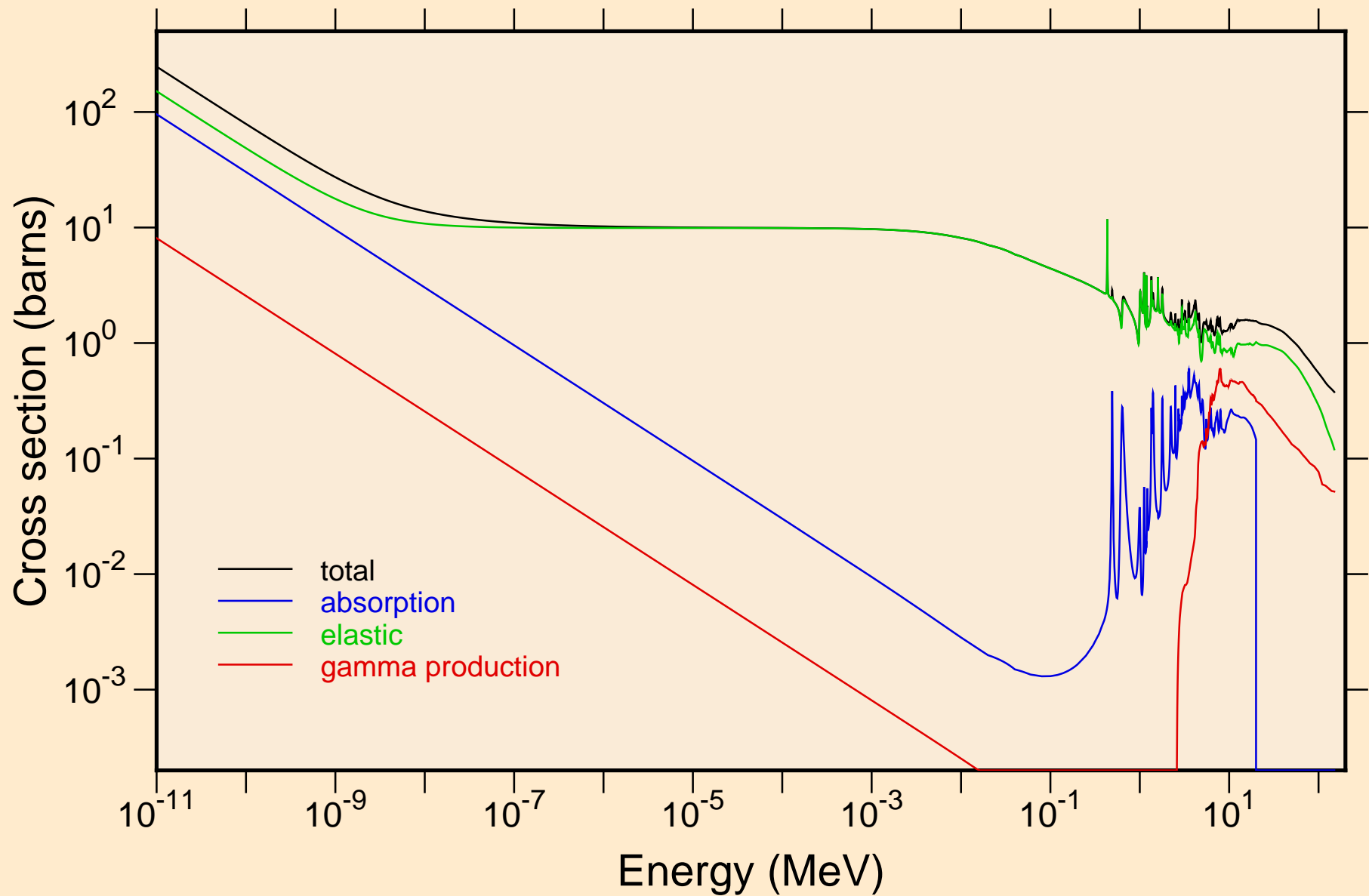

N014 ENDF/B-VIII.0 NJOY12.111 293.6K
resonance total cross section

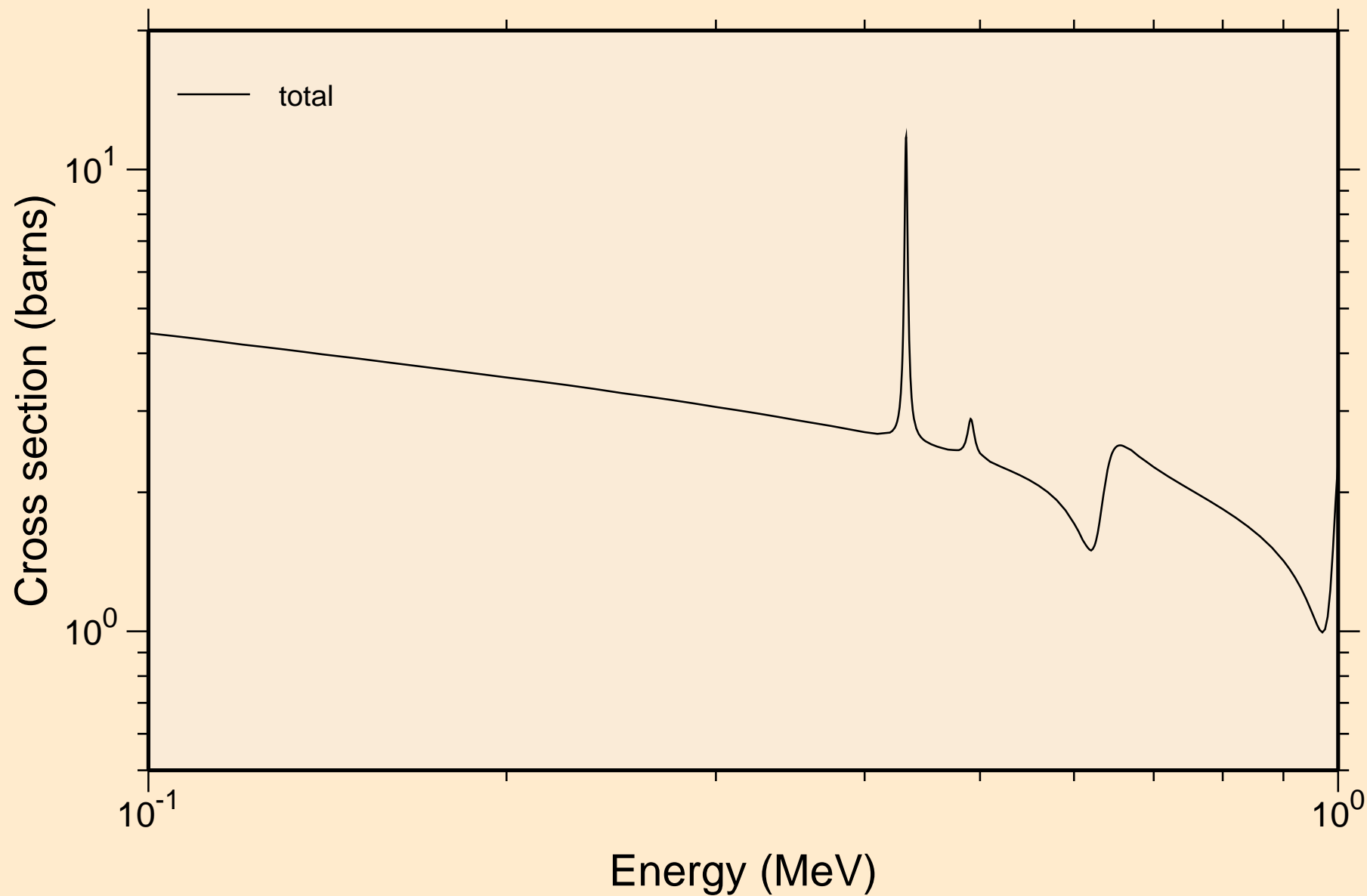

N014 ENDF/B-VIII.0 NJOY12.111 293.6K
resonance total cross section

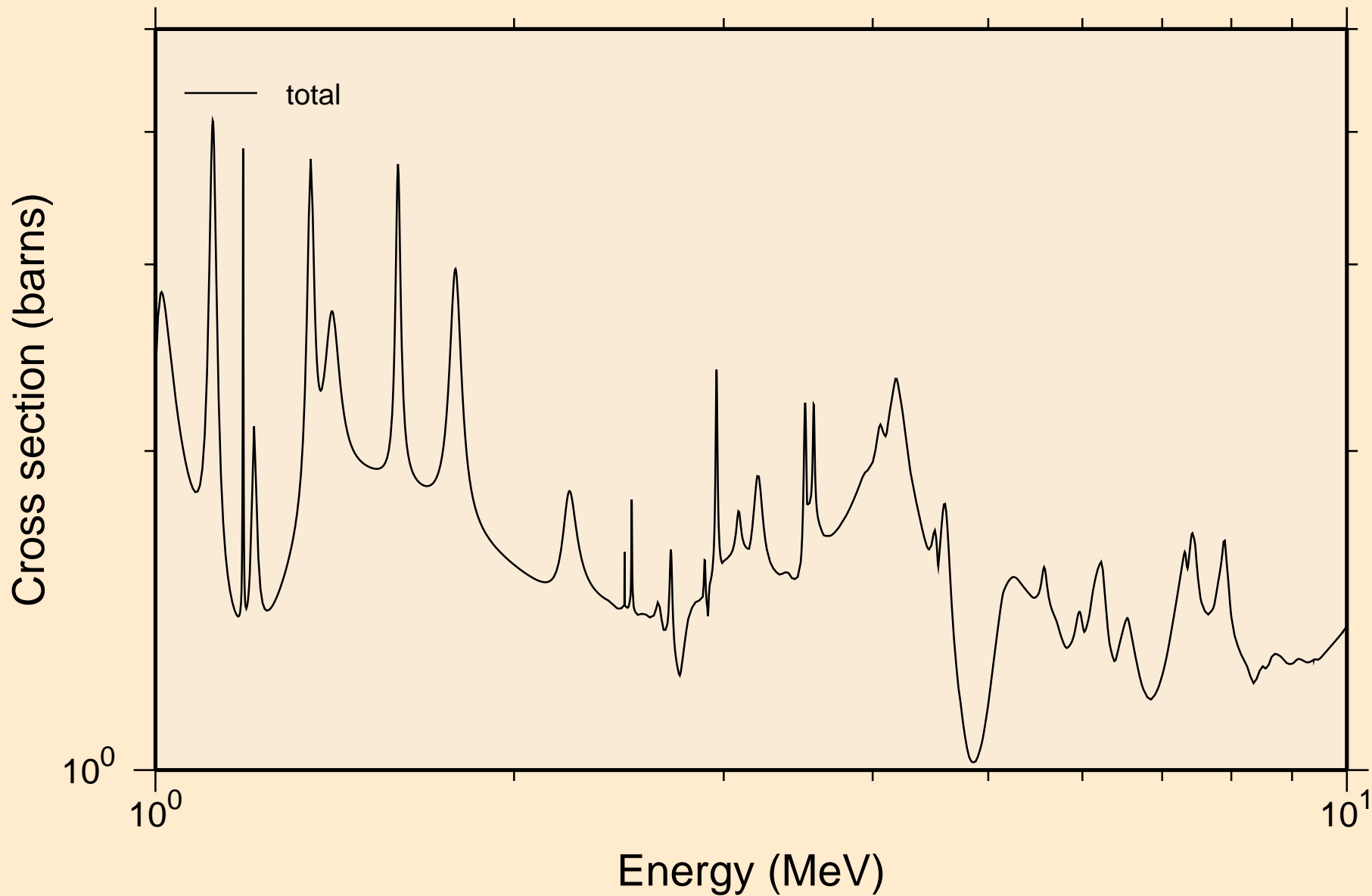

N014 ENDF/B-VIII.0 NJOY12.111 293.6K
resonance absorption cross sections

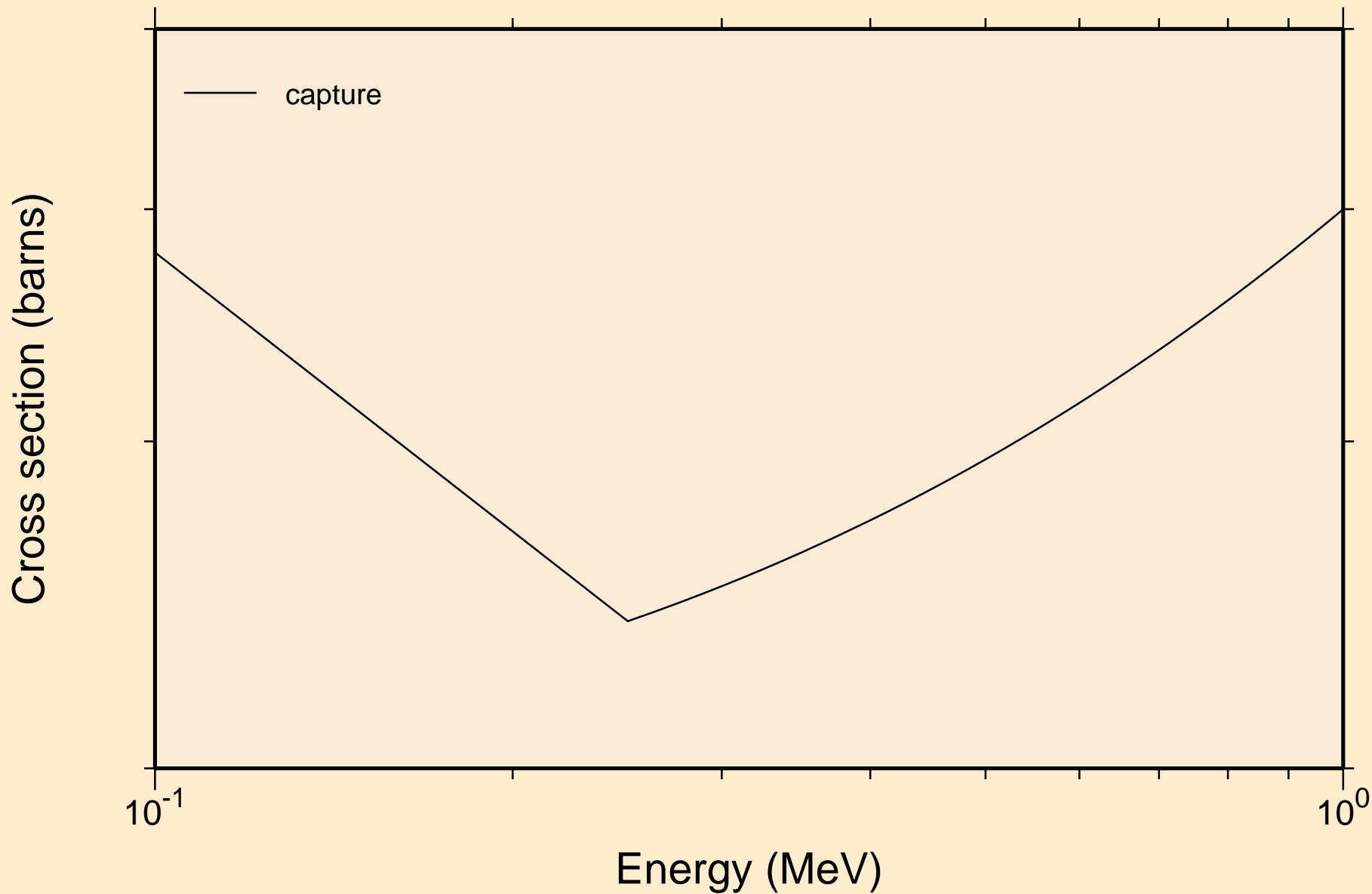

N014 ENDF/B-VIII.0 NJOY12.111 293.6K
resonance absorption cross sections

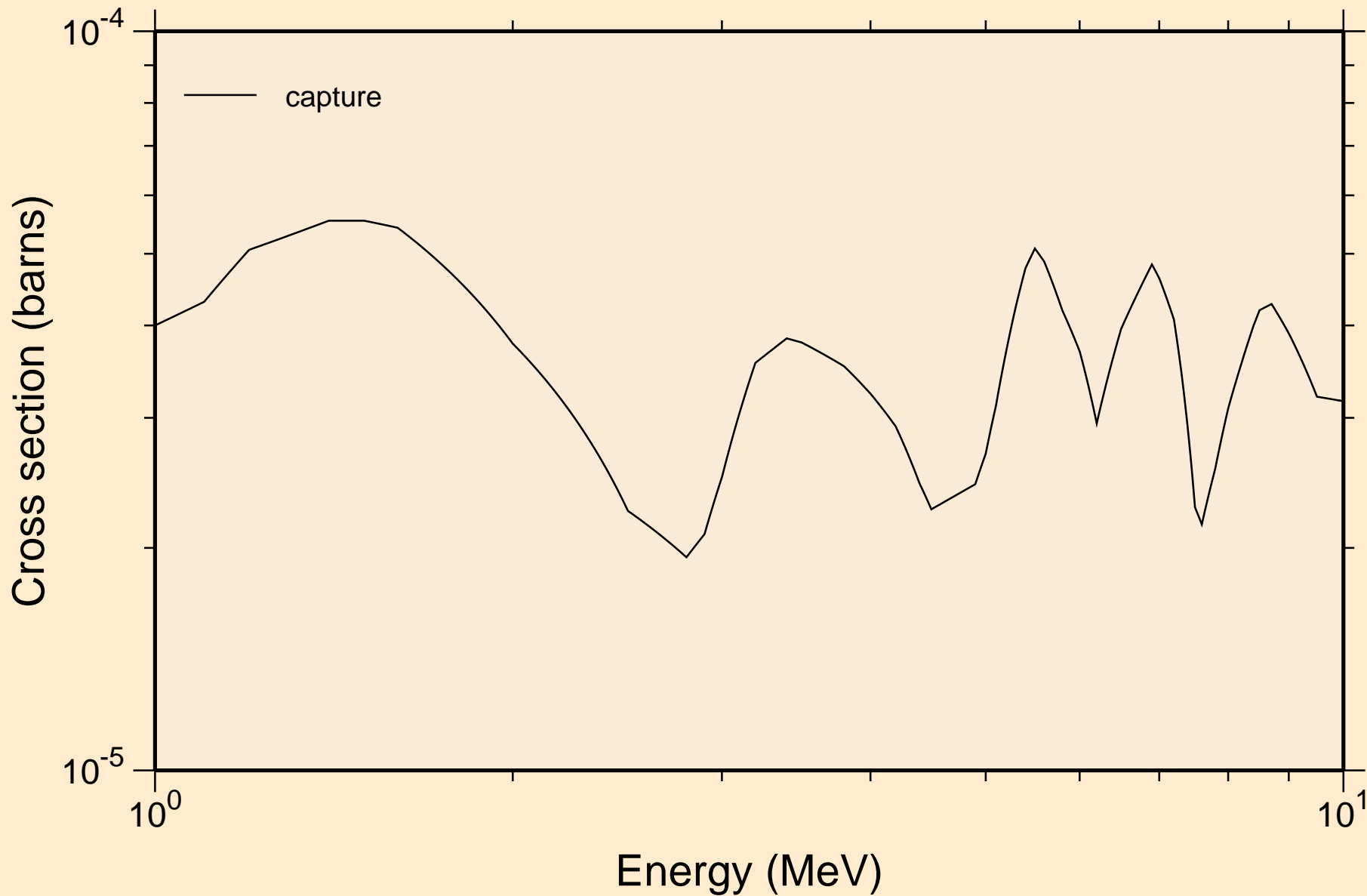

N014 ENDF/B-VIII.0 NJOY12.111 293.6K

Heating

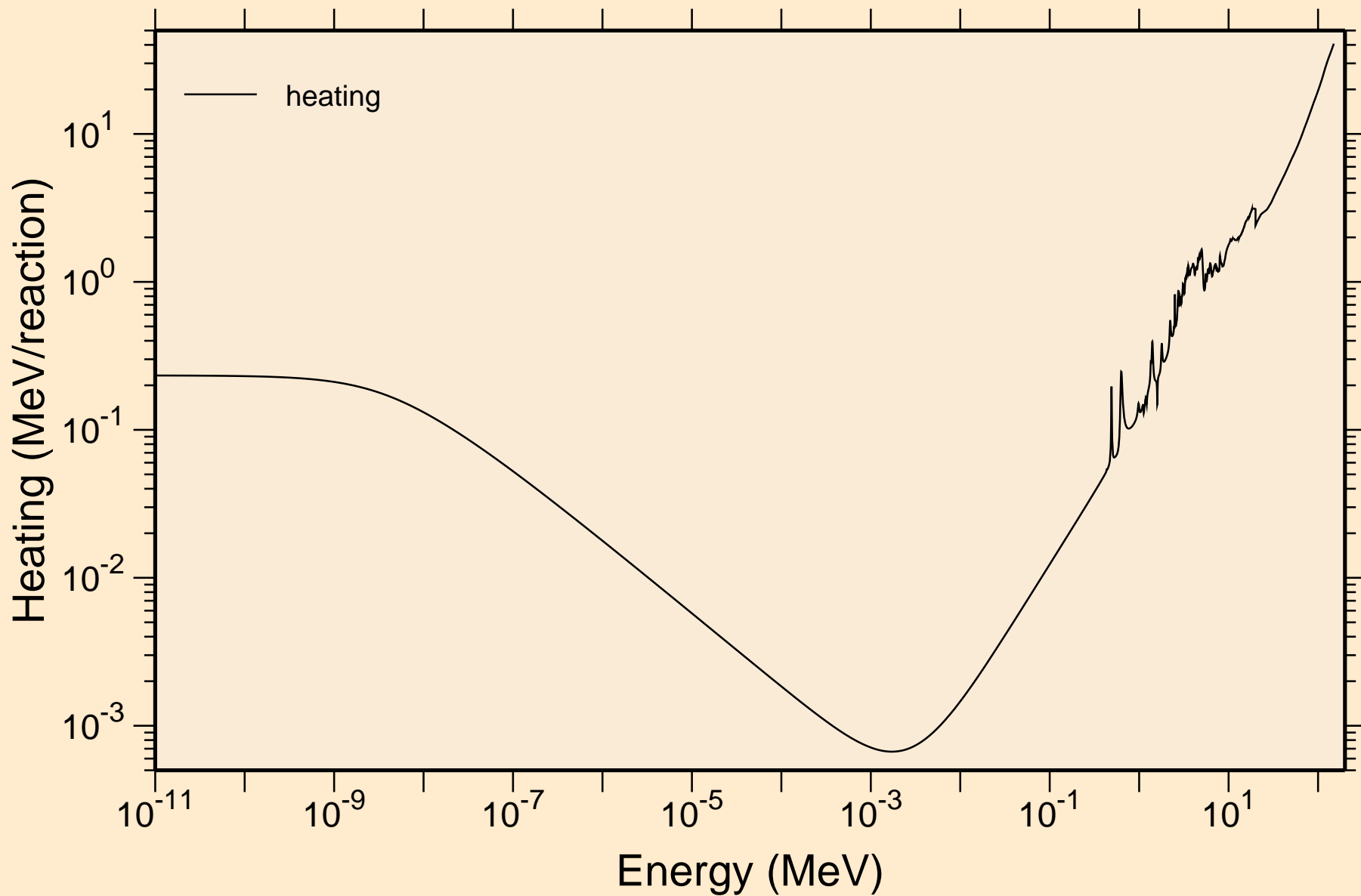

N014 ENDF/B-VIII.0 NJOY12.111 293.6K

Damage

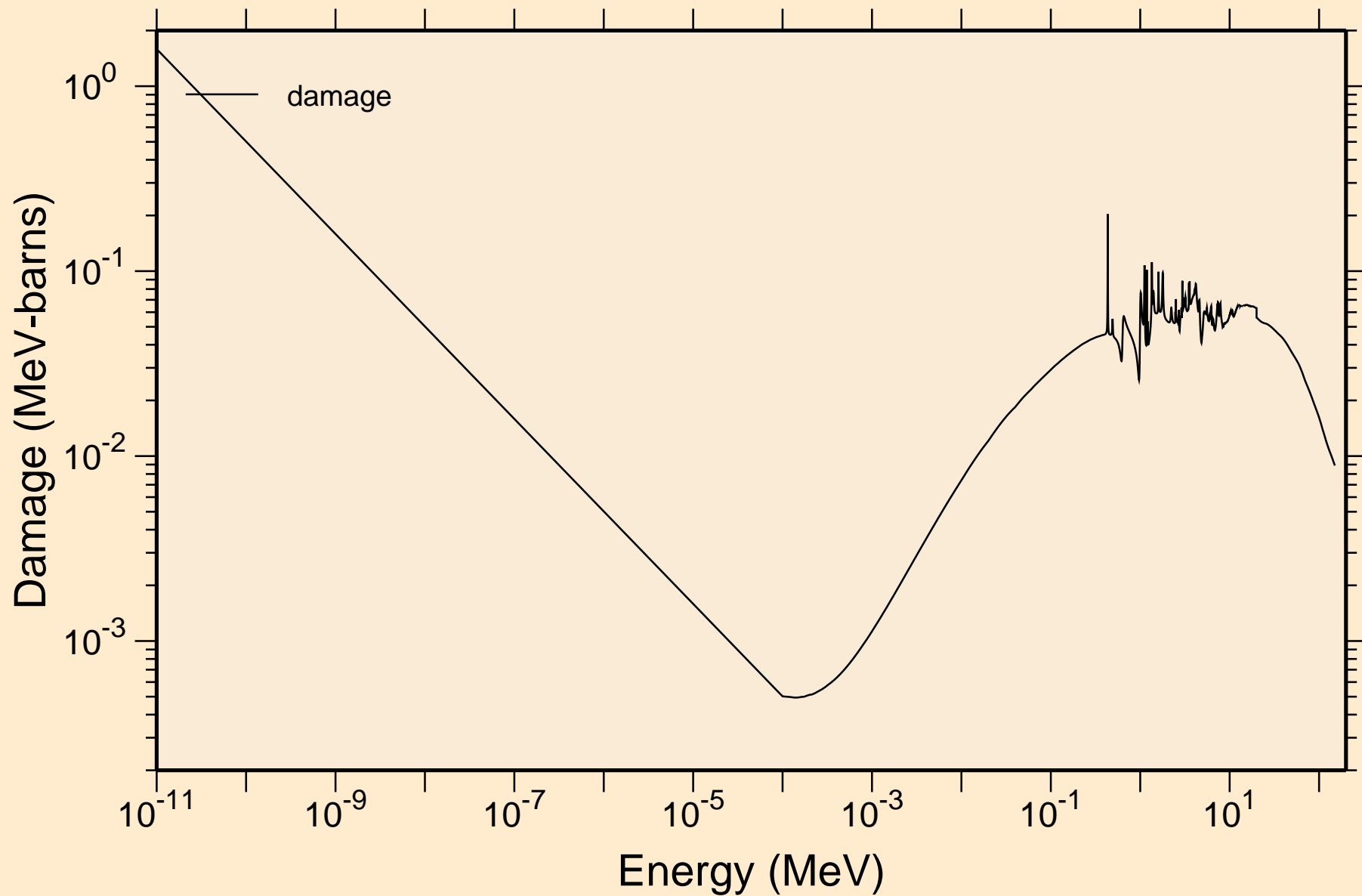

N014 ENDF/B-VIII.0 NJOY12.111 293.6K

Non-threshold reactions

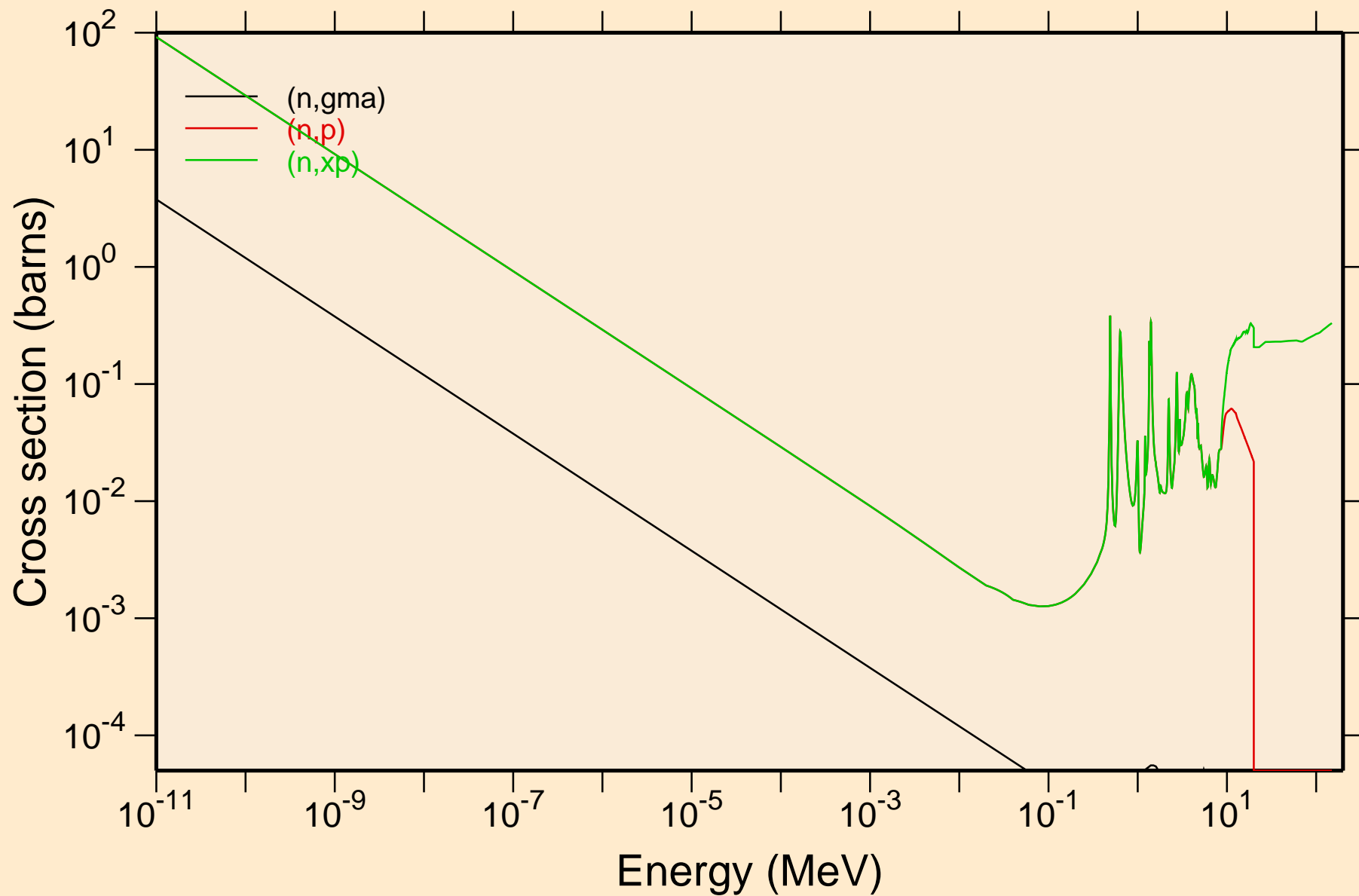

N014 ENDF/B-VIII.0 NJOY12.111 293.6K

Principal cross sections

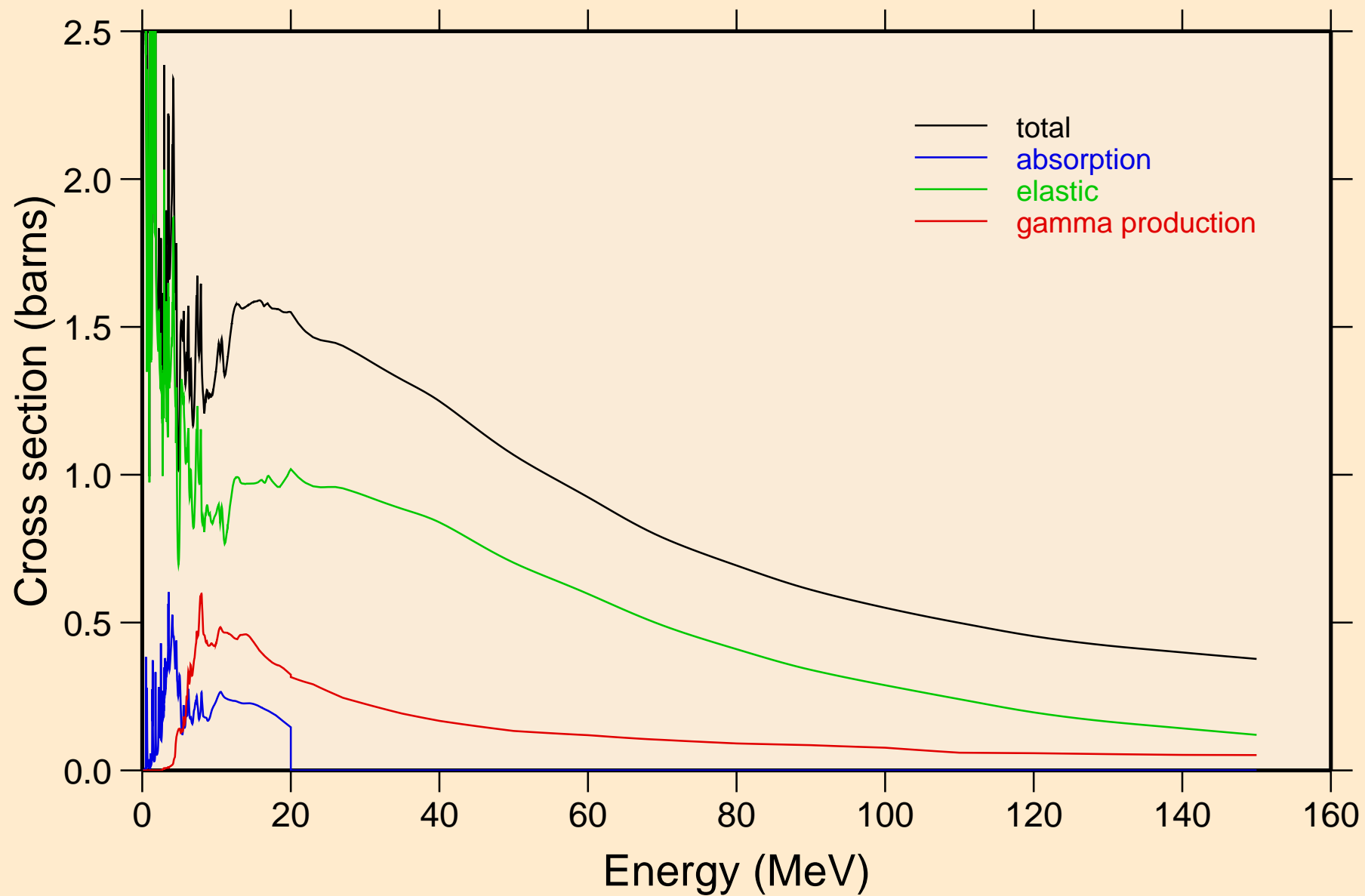

N014 ENDF/B-VIII.0 NJOY12.111 293.6K

Heating

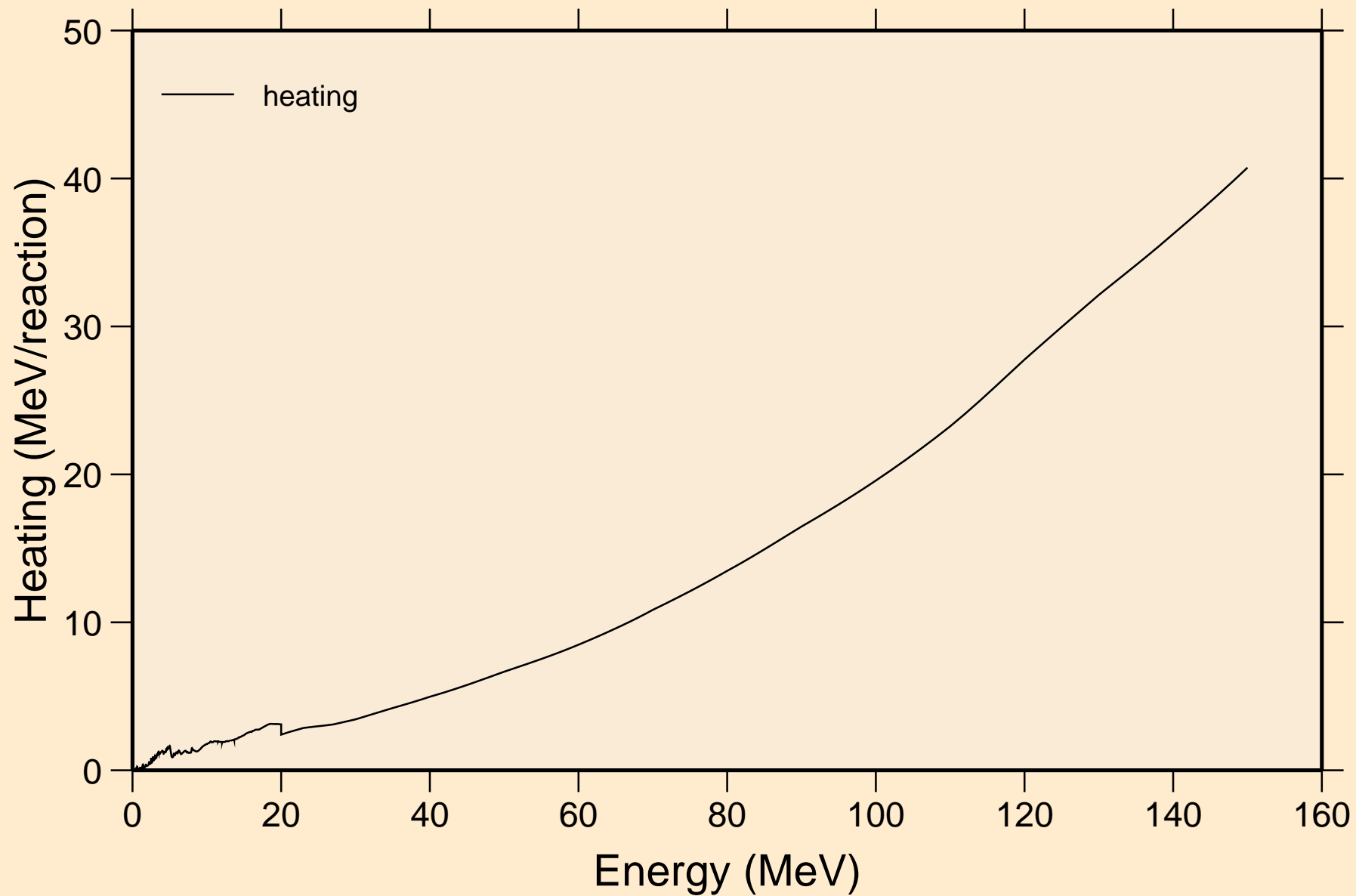

N014 ENDF/B-VIII.0 NJOY12.111 293.6K

Damage

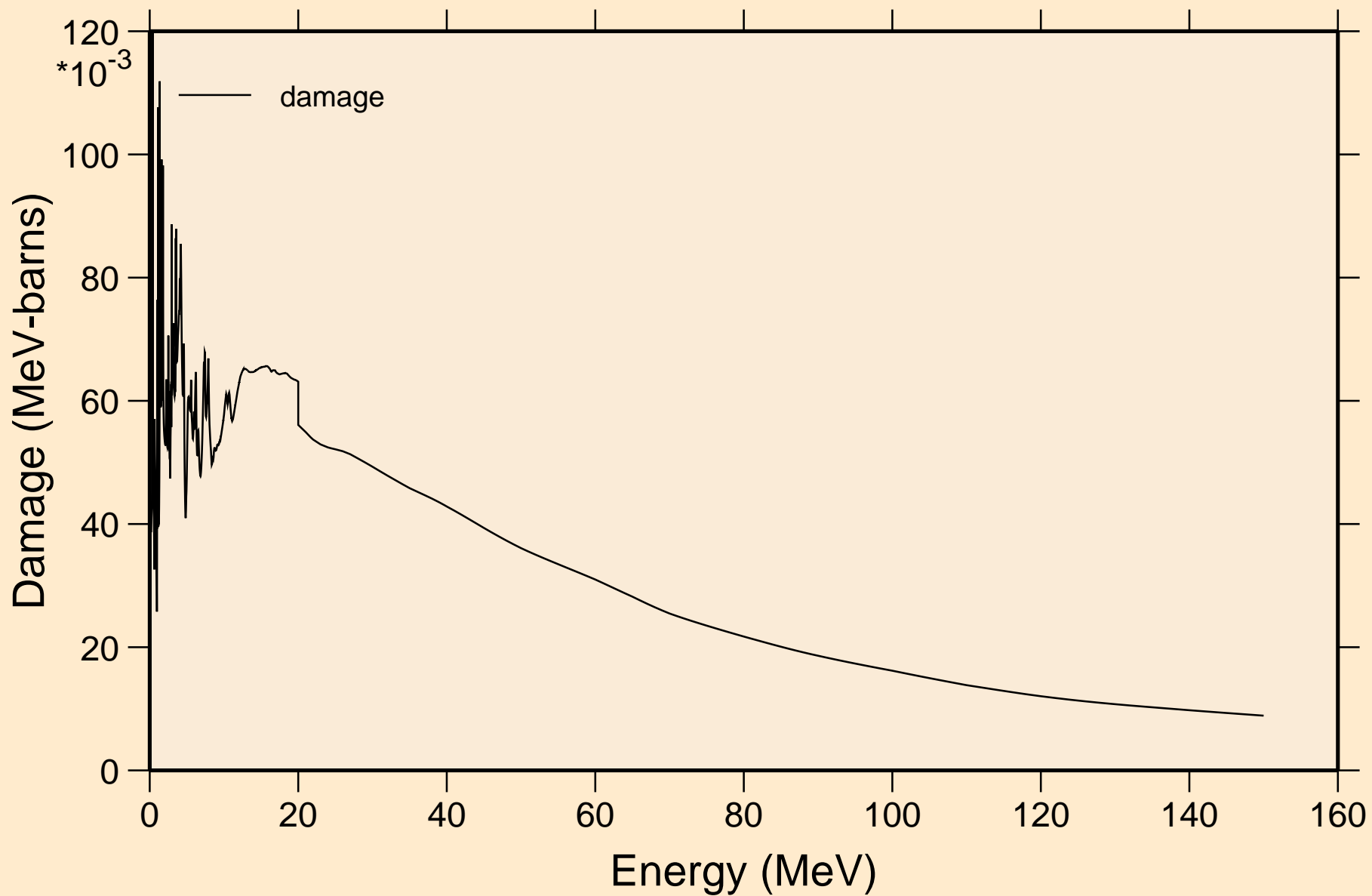

N014 ENDF/B-VIII.0 NJOY12.111 293.6K

Non-threshold reactions

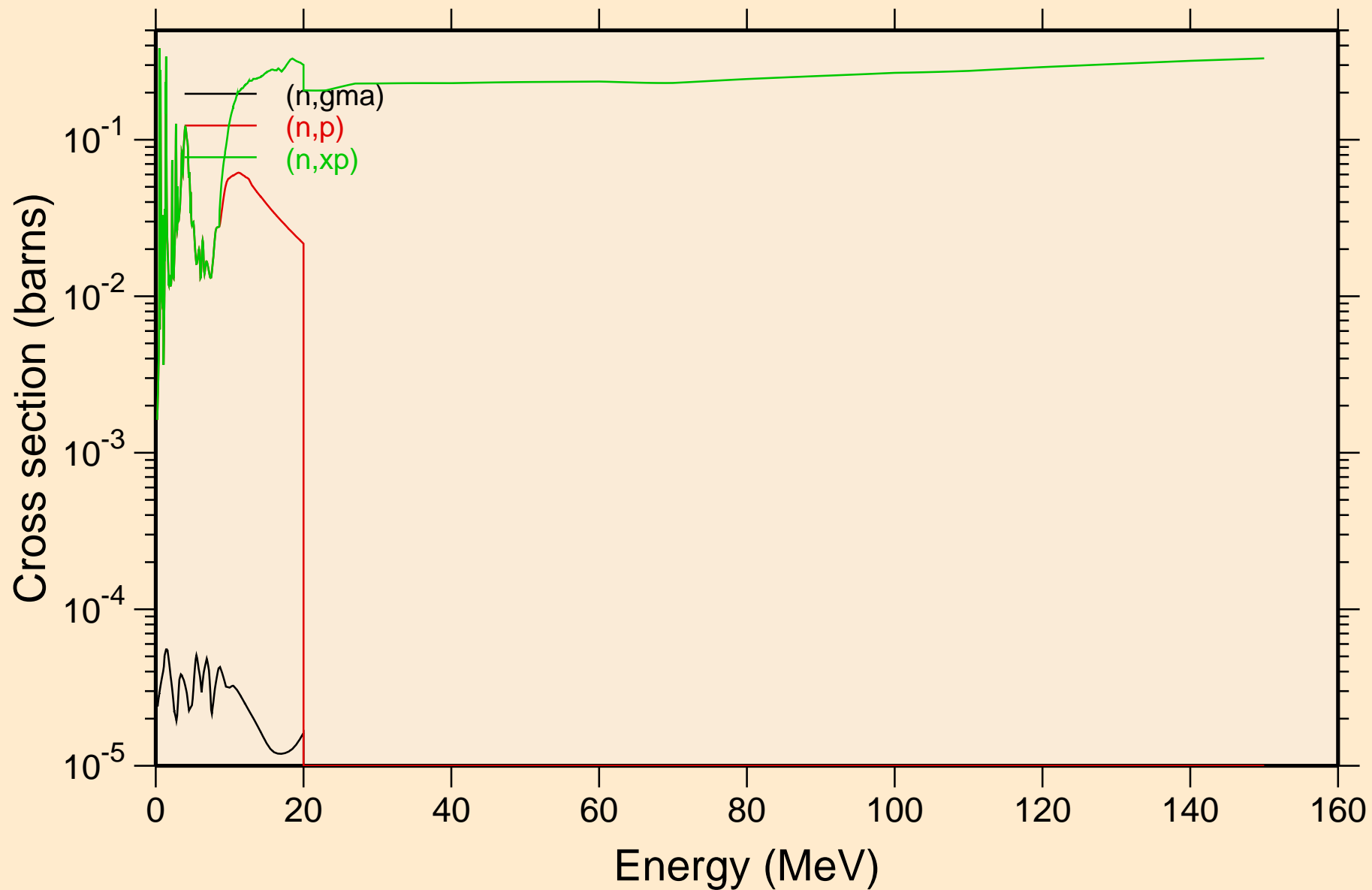

N014 ENDF/B-VIII.0 NJOY12.111 293.6K

Inelastic levels

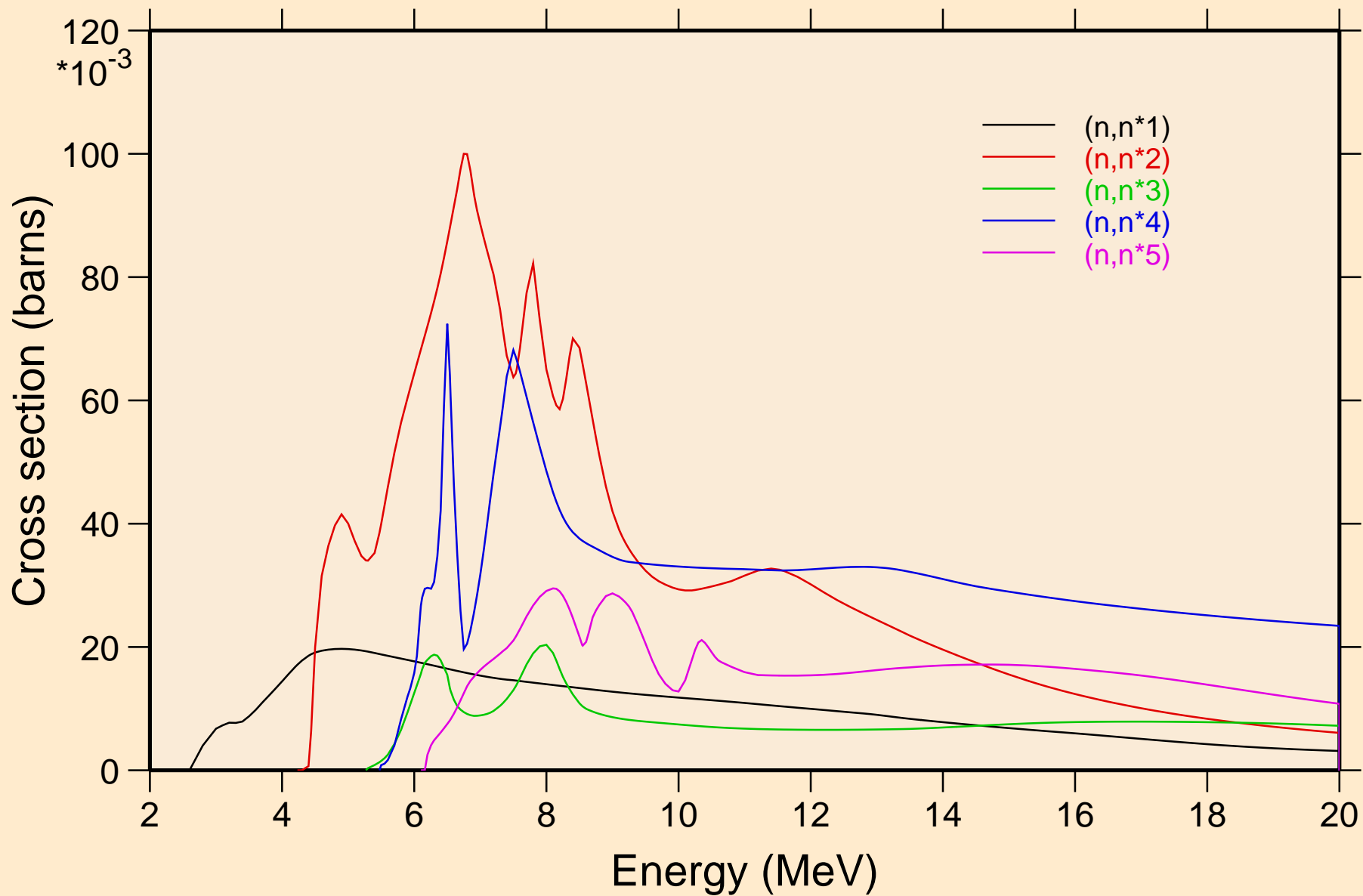

N014 ENDF/B-VIII.0 NJOY12.111 293.6K

Inelastic levels

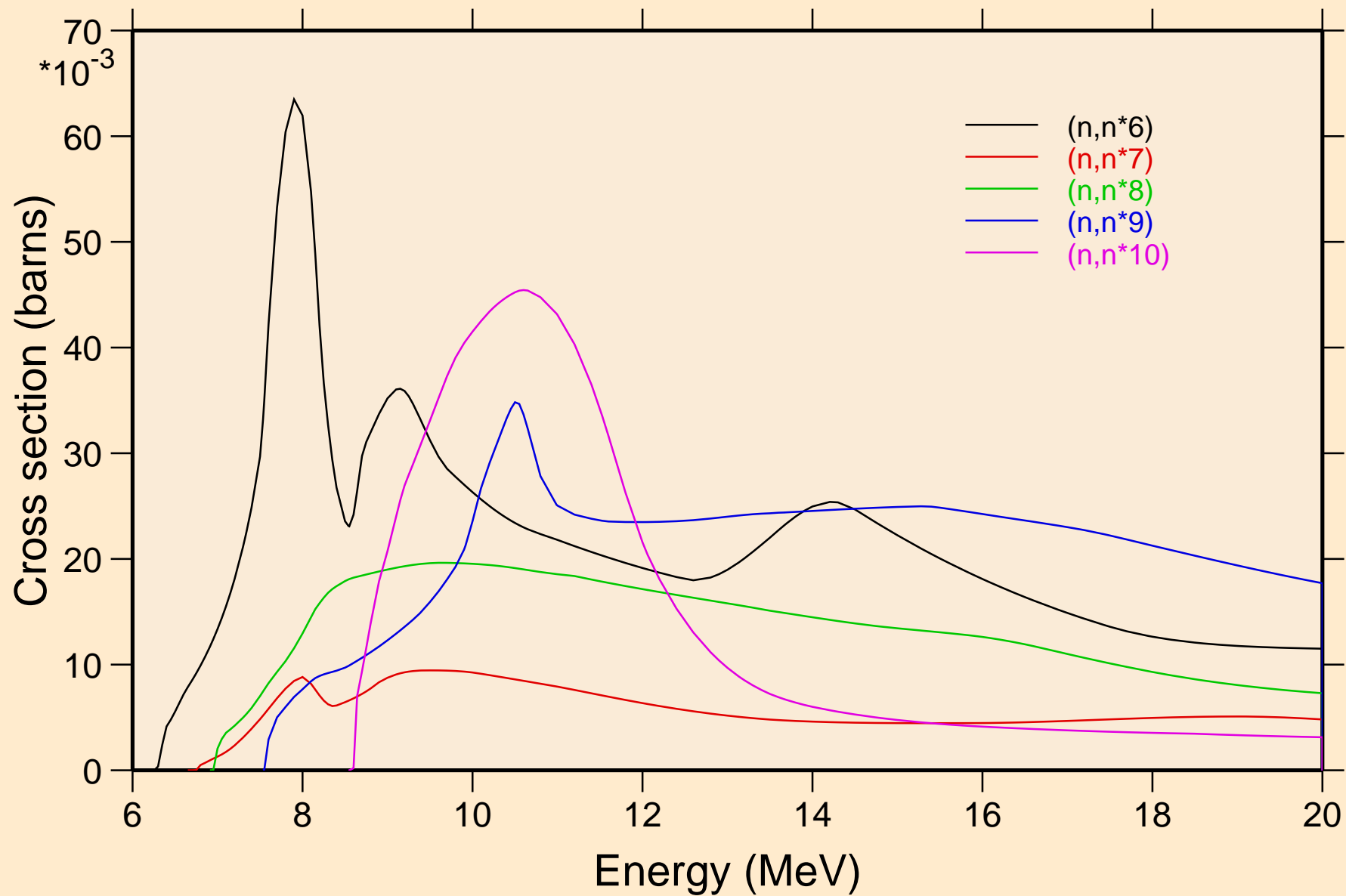

N014 ENDF/B-VIII.0 NJOY12.111 293.6K

Inelastic levels

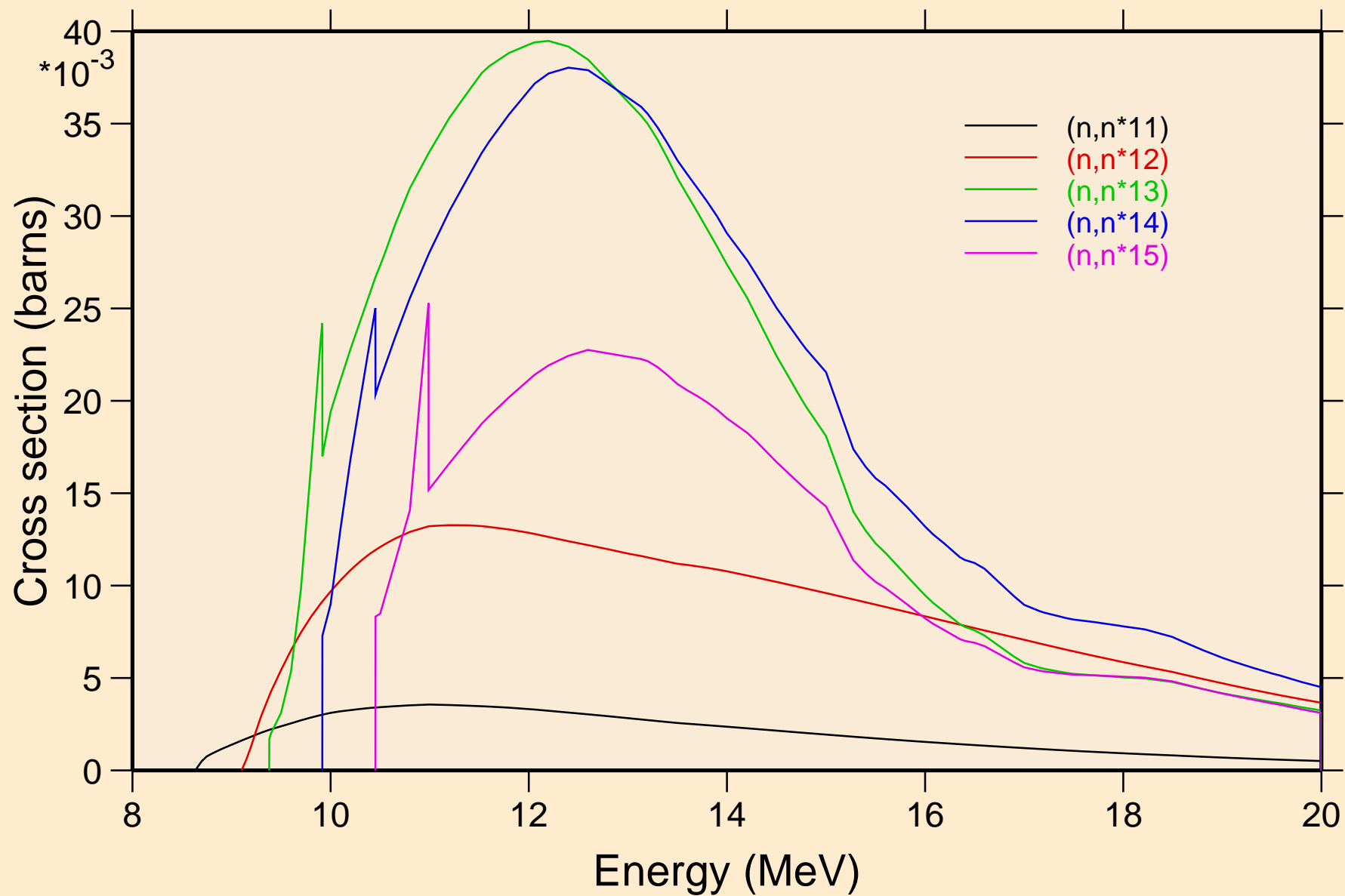

N014 ENDF/B-VIII.0 NJOY12.111 293.6K

Inelastic levels

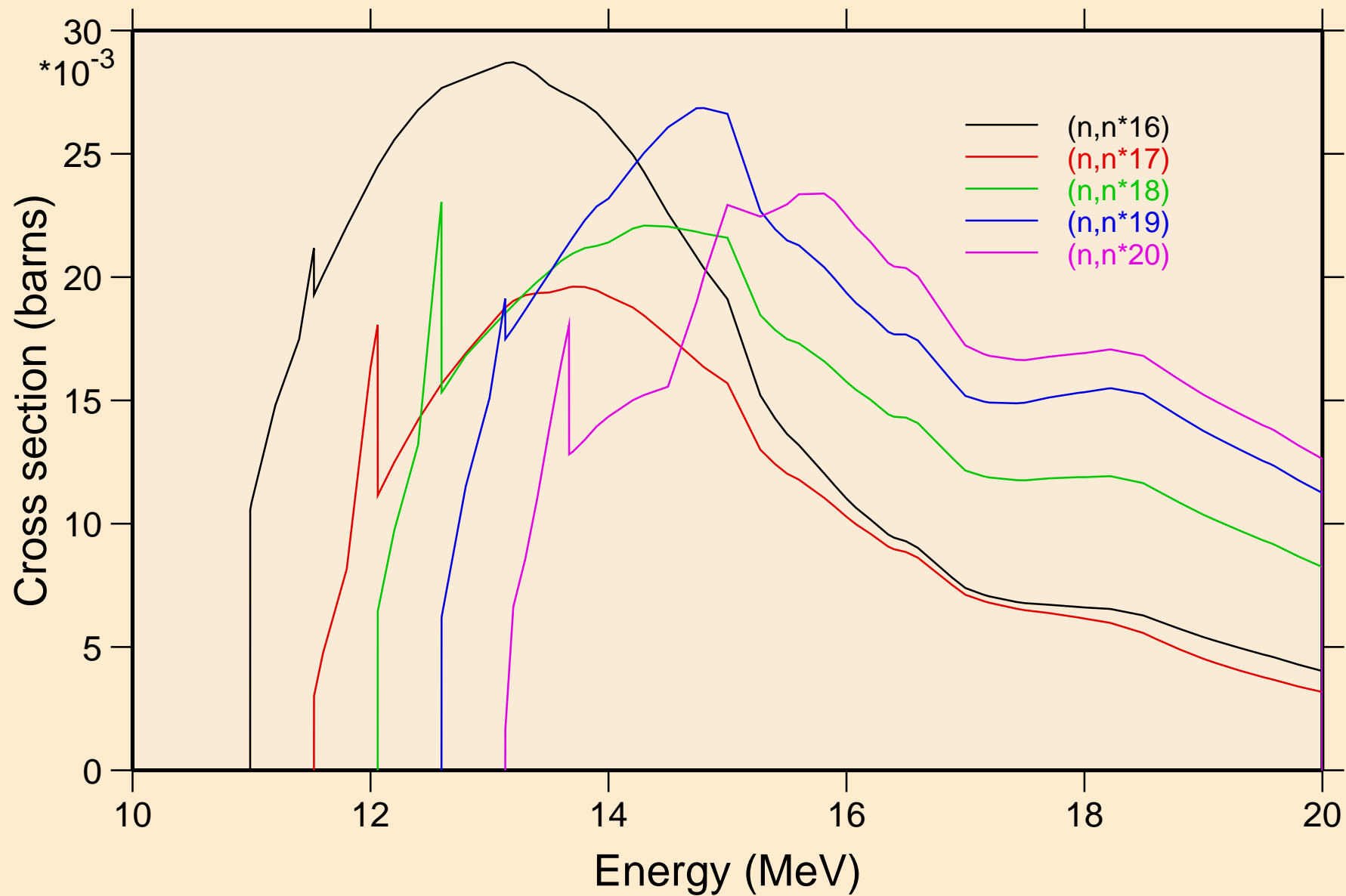

N014 ENDF/B-VIII.0 NJOY12.111 293.6K

Inelastic levels

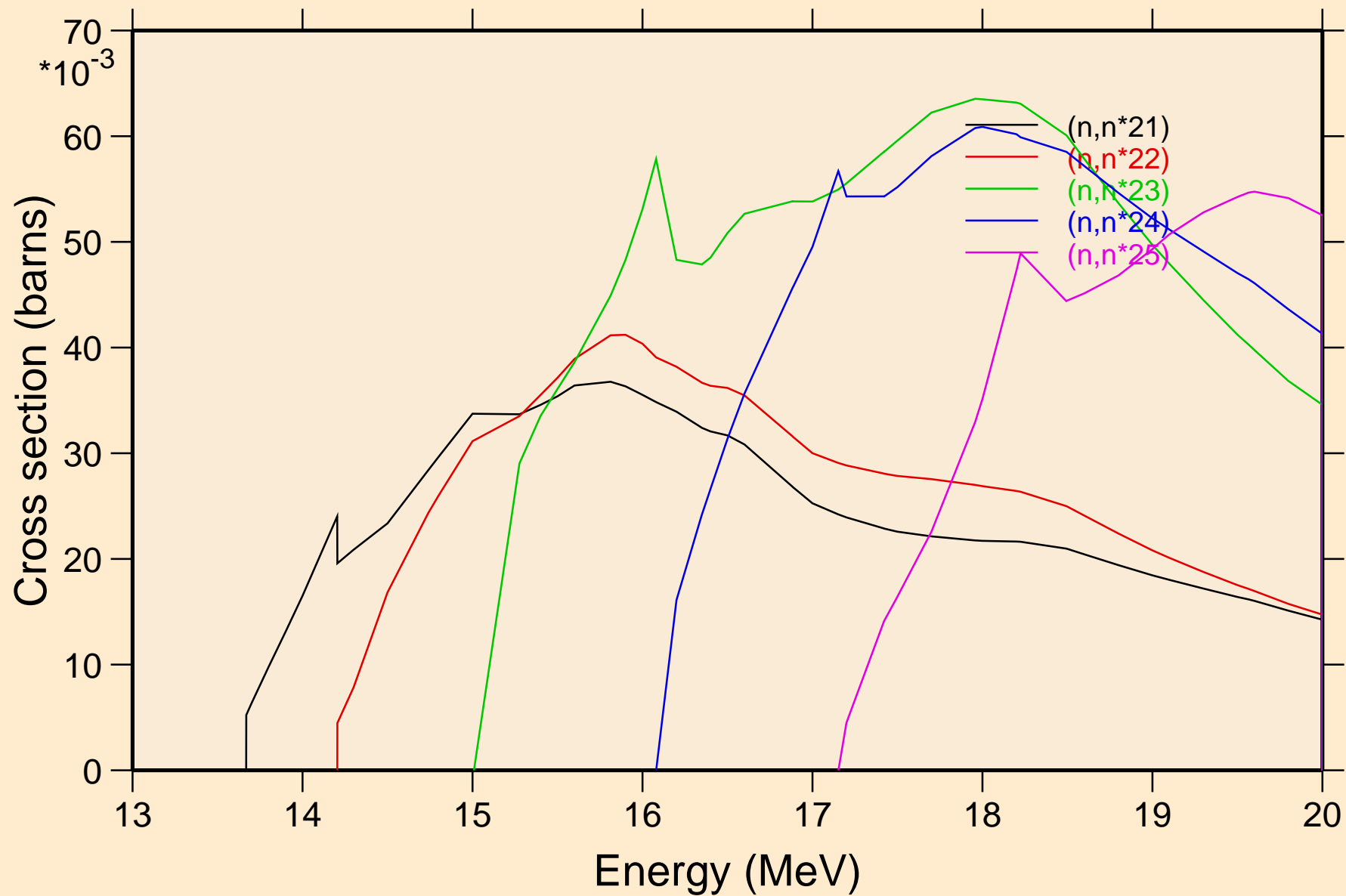

N014 ENDF/B-VIII.0 NJOY12.111 293.6K

Inelastic levels

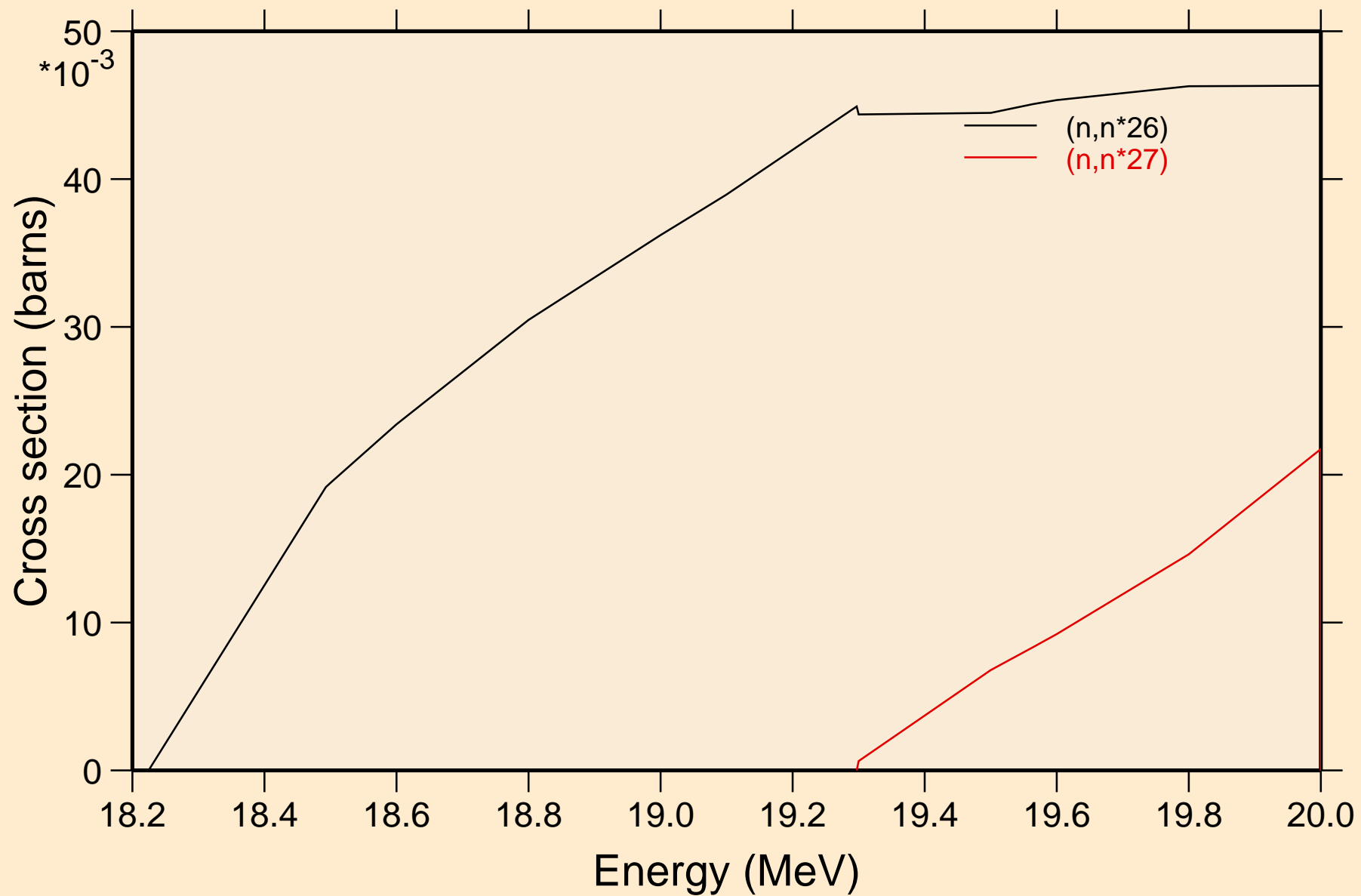

N014 ENDF/B-VIII.0 NJOY12.111 293.6K

Threshold reactions

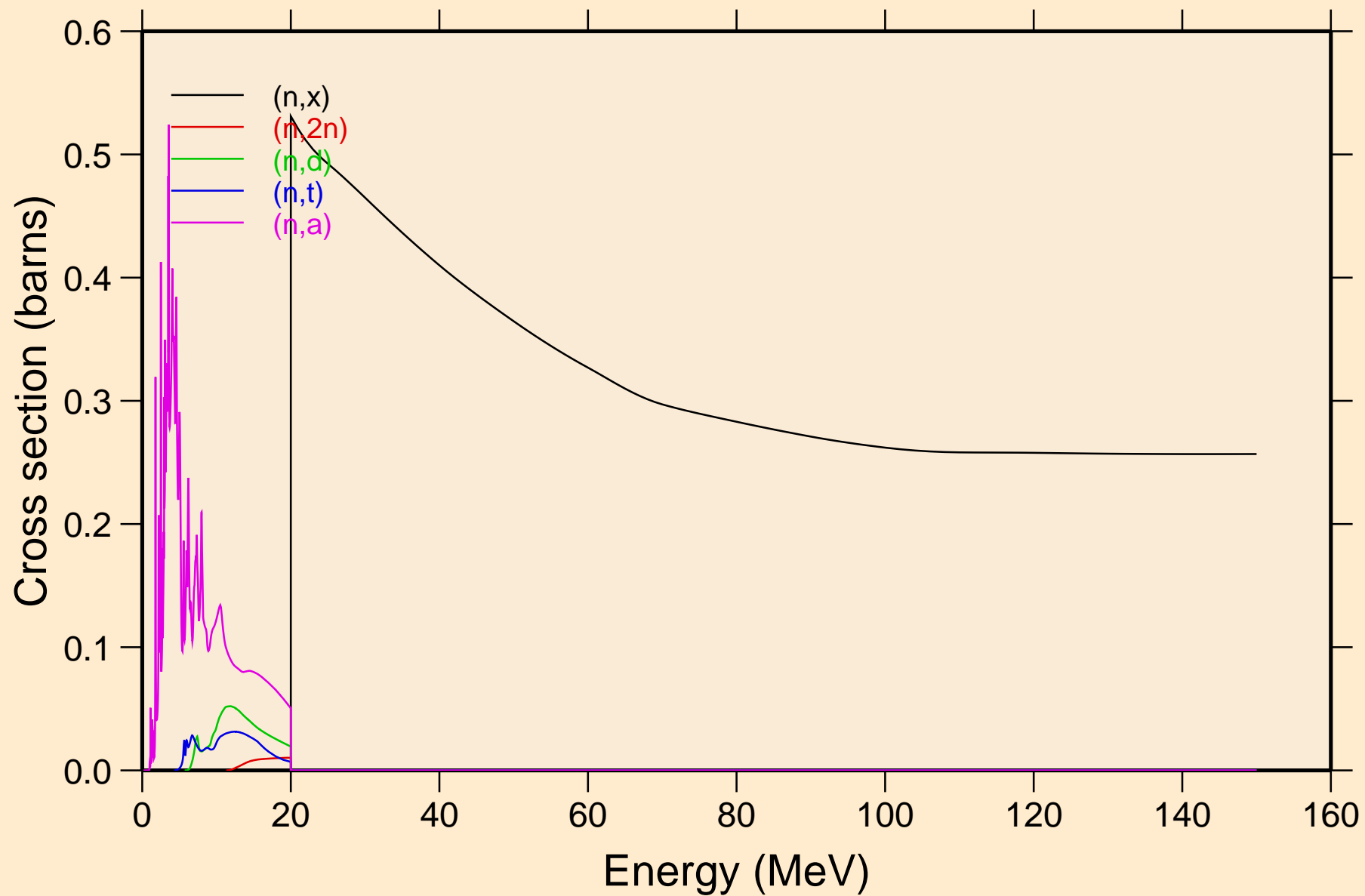

N014 ENDF/B-VIII.0 NJOY12.111 293.6K

Threshold reactions

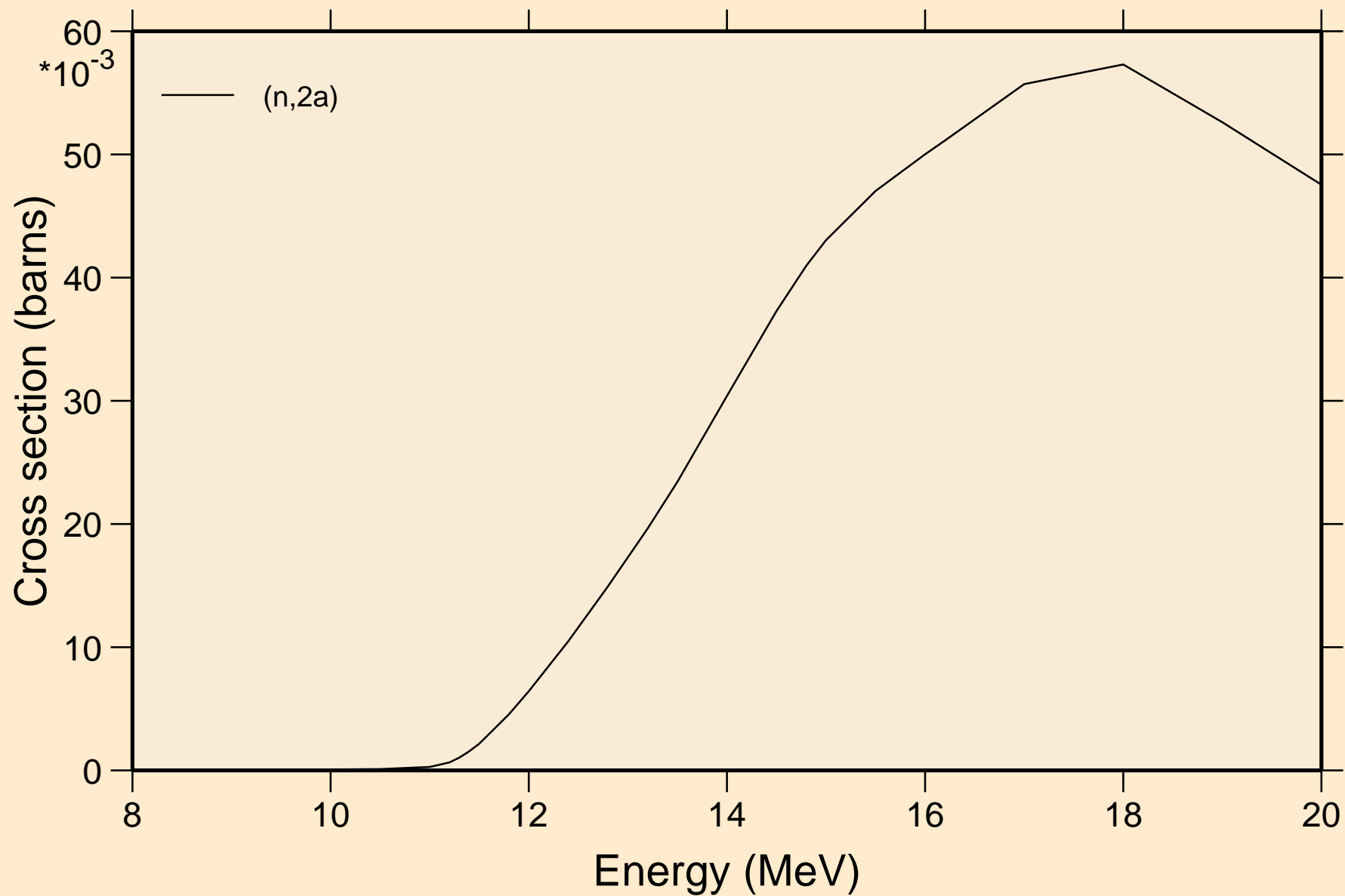

N014 ENDF/B-VIII.0 NJOY12.111 293.6K

Threshold reactions

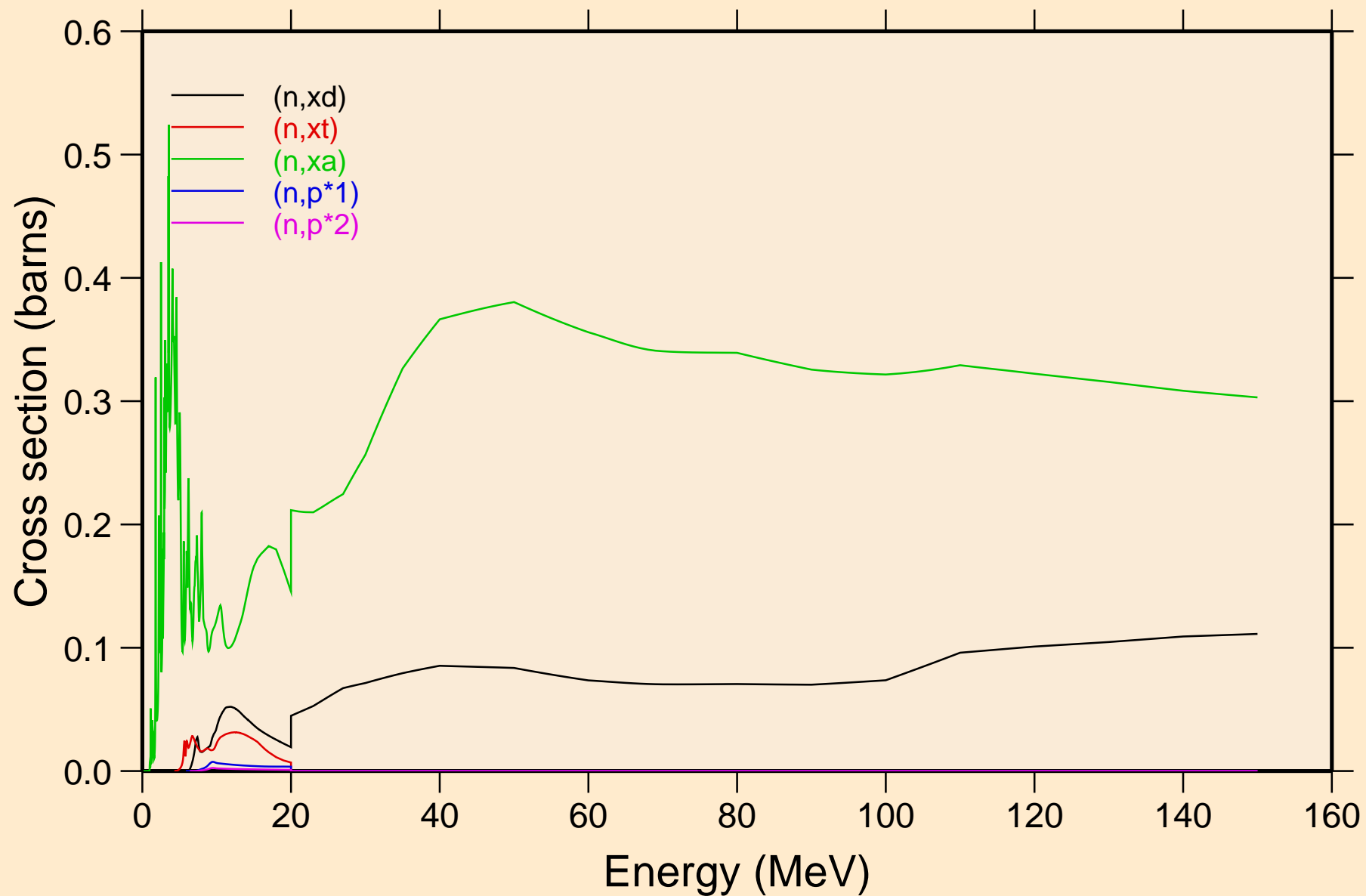

N014 ENDF/B-VIII.0 NJOY12.111 293.6K

Threshold reactions

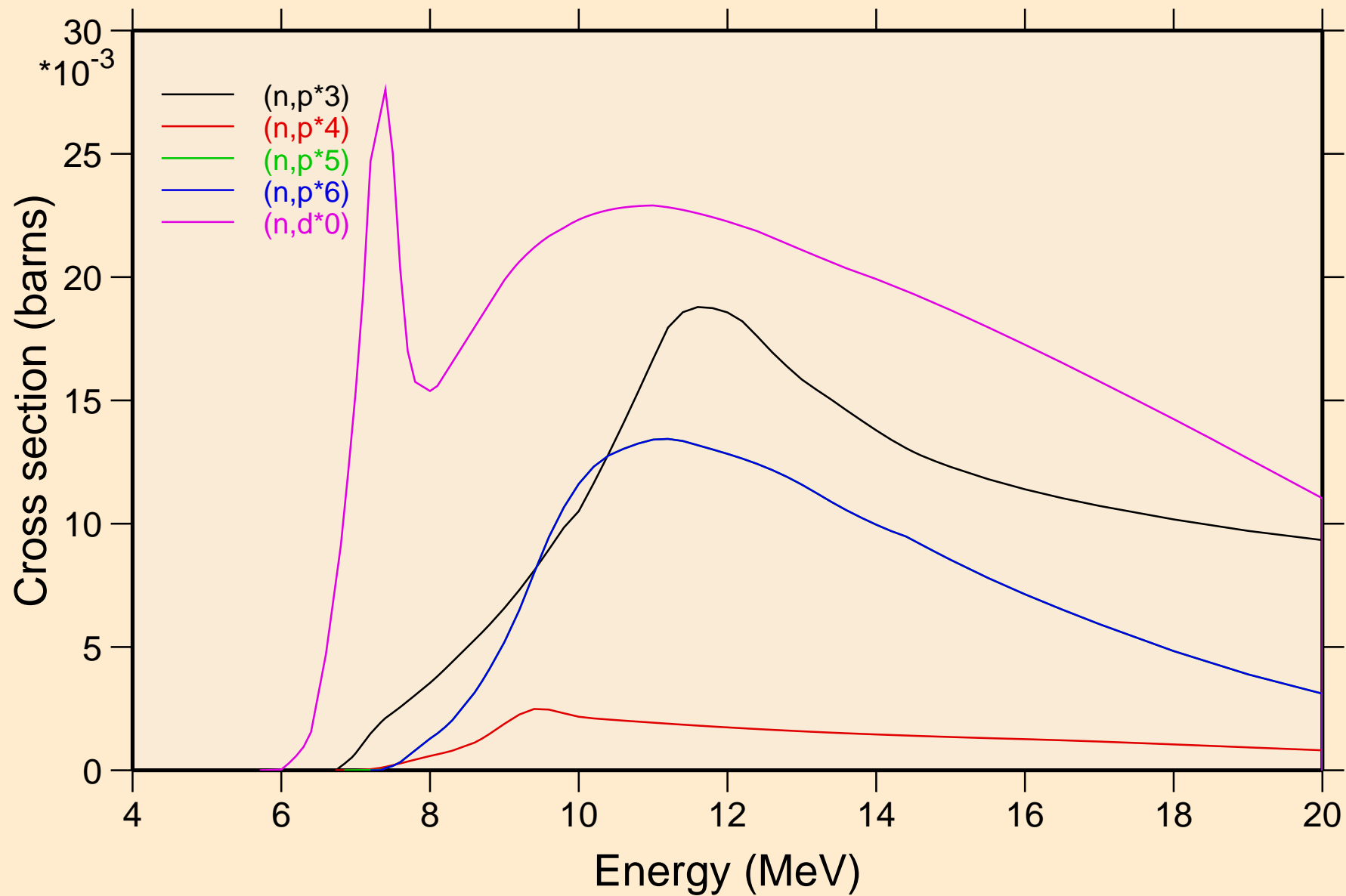

N014 ENDF/B-VIII.0 NJOY12.111 293.6K

Threshold reactions

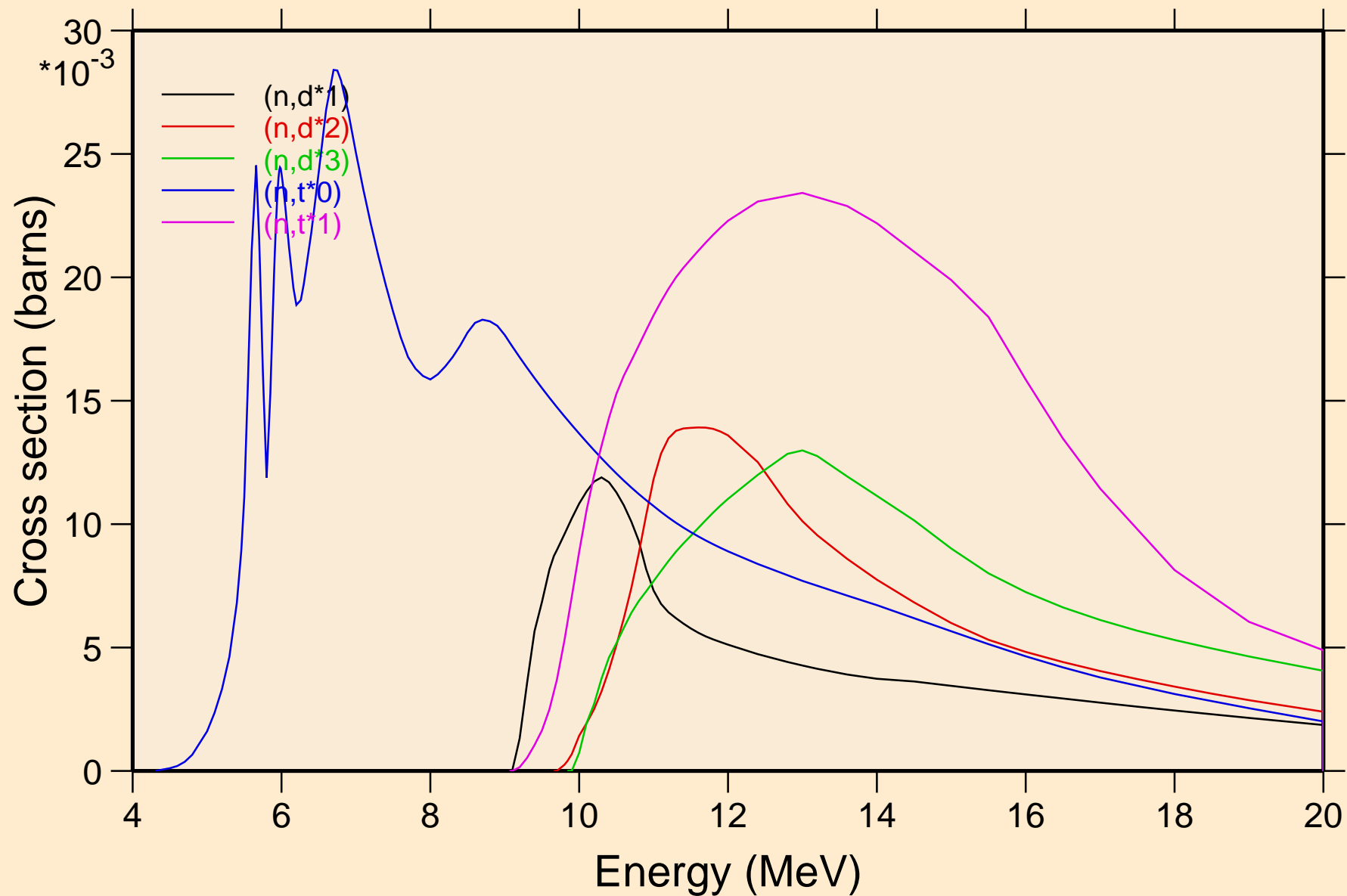

N014 ENDF/B-VIII.0 NJOY12.111 293.6K

Threshold reactions

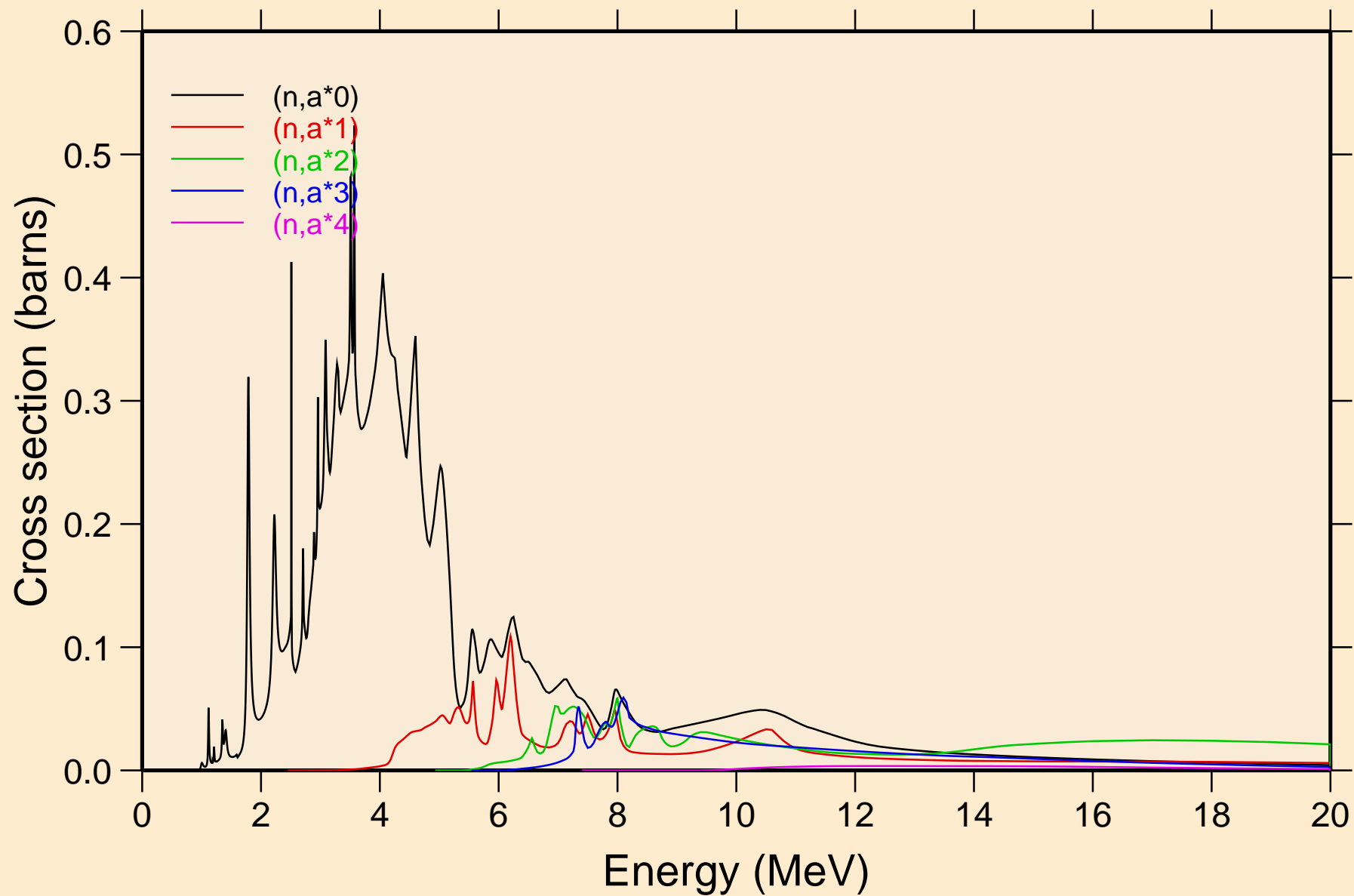

N014 ENDF/B-VIII.0 NJOY12.111 293.6K

Threshold reactions

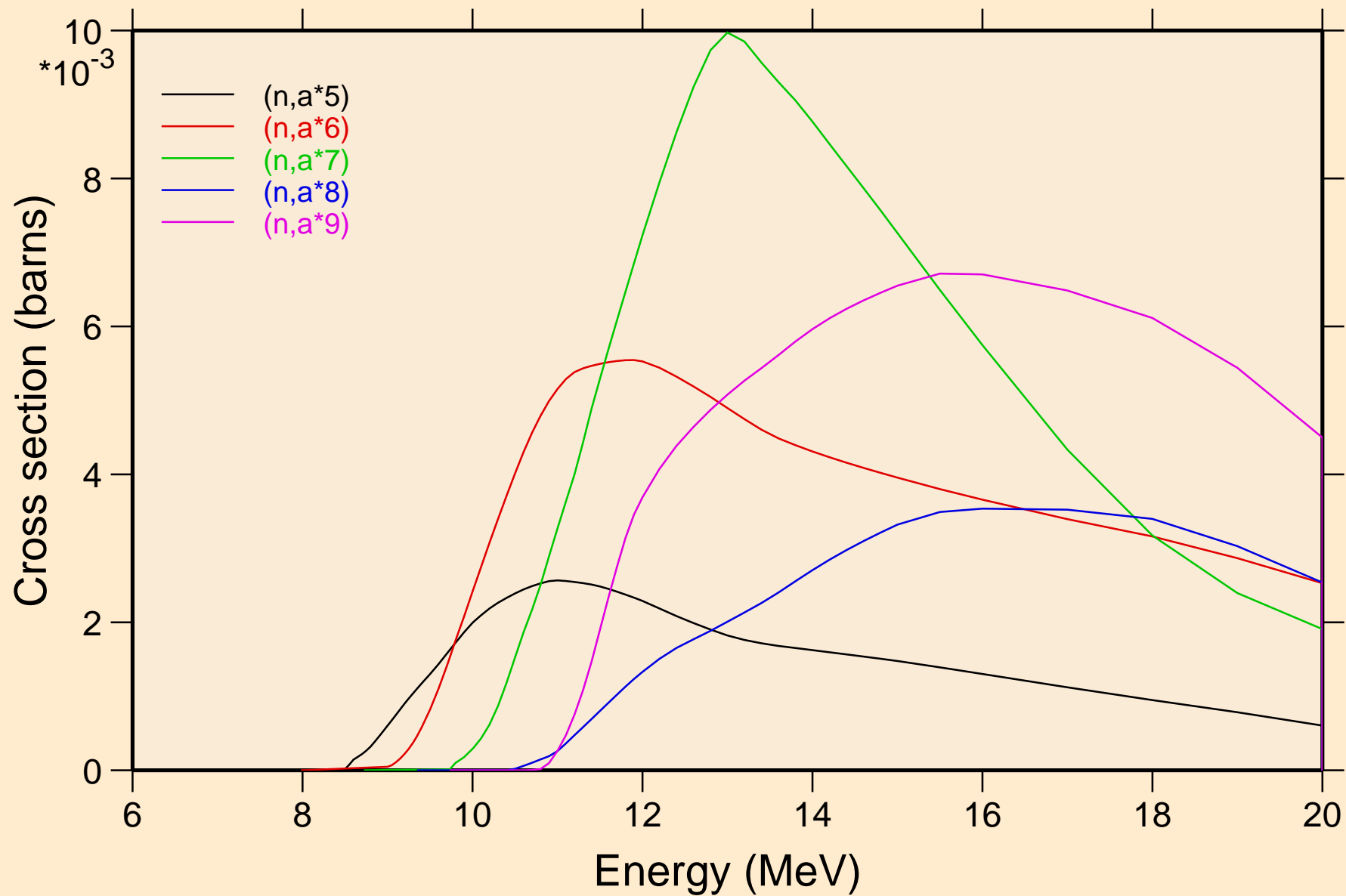

N014 ENDF/B-VIII.0 NJOY12.111 293.6K

Threshold reactions

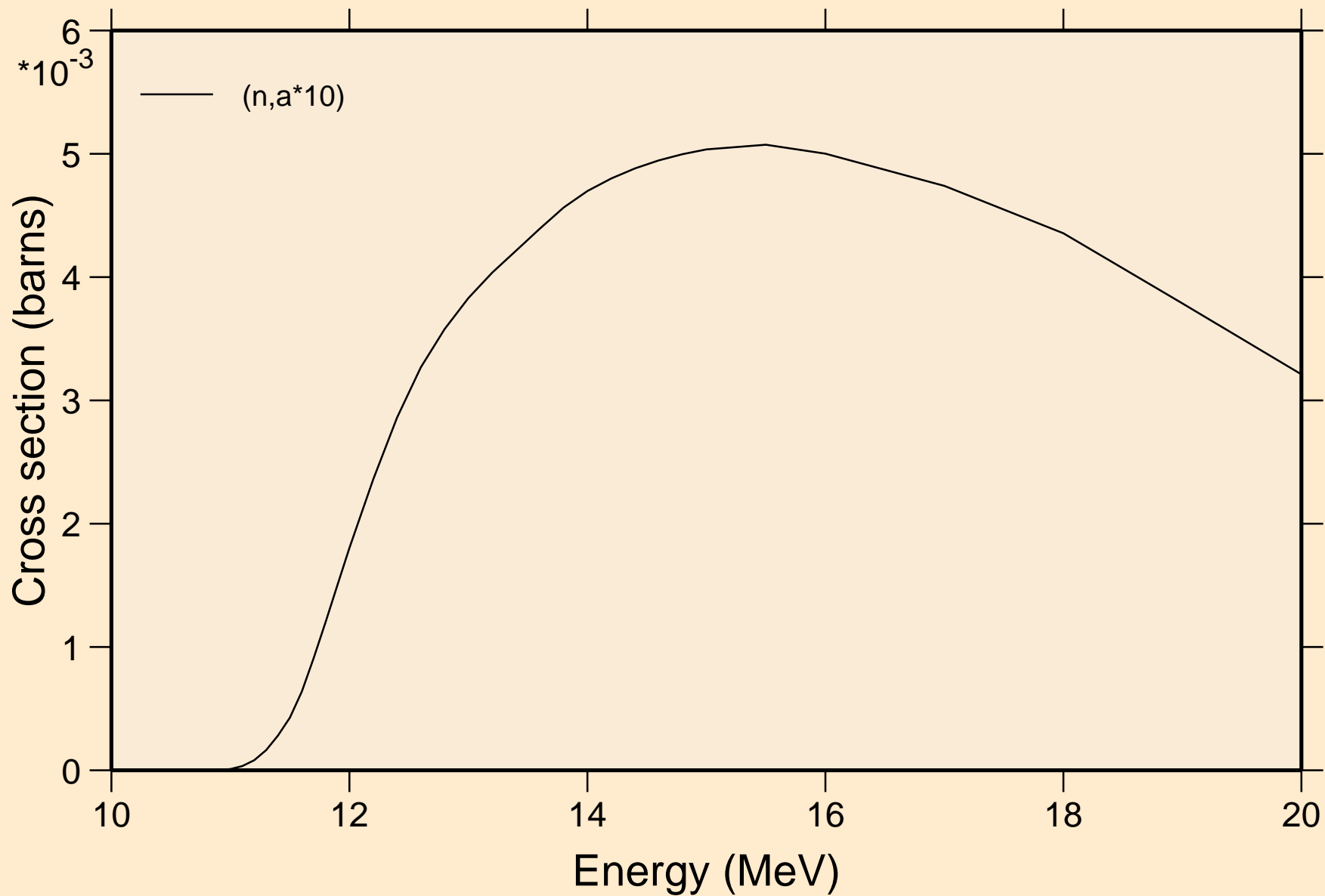

N014 ENDF/B-VIII.0 NJOY12.111 293.6K
angular distribution for elastic

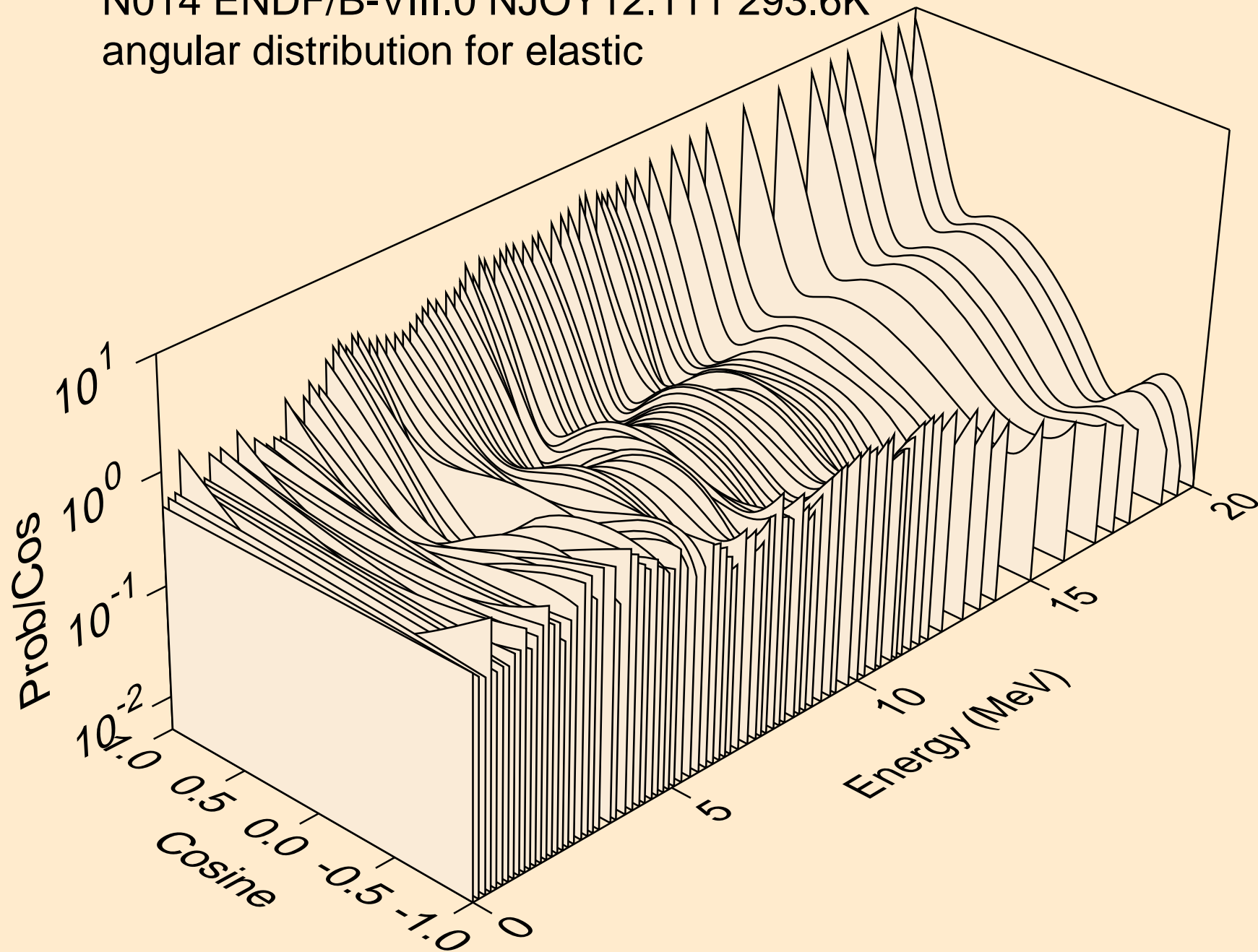

N014 ENDF/B-VIII.0 NJOY12.111 293.6K
angular distribution for elastic

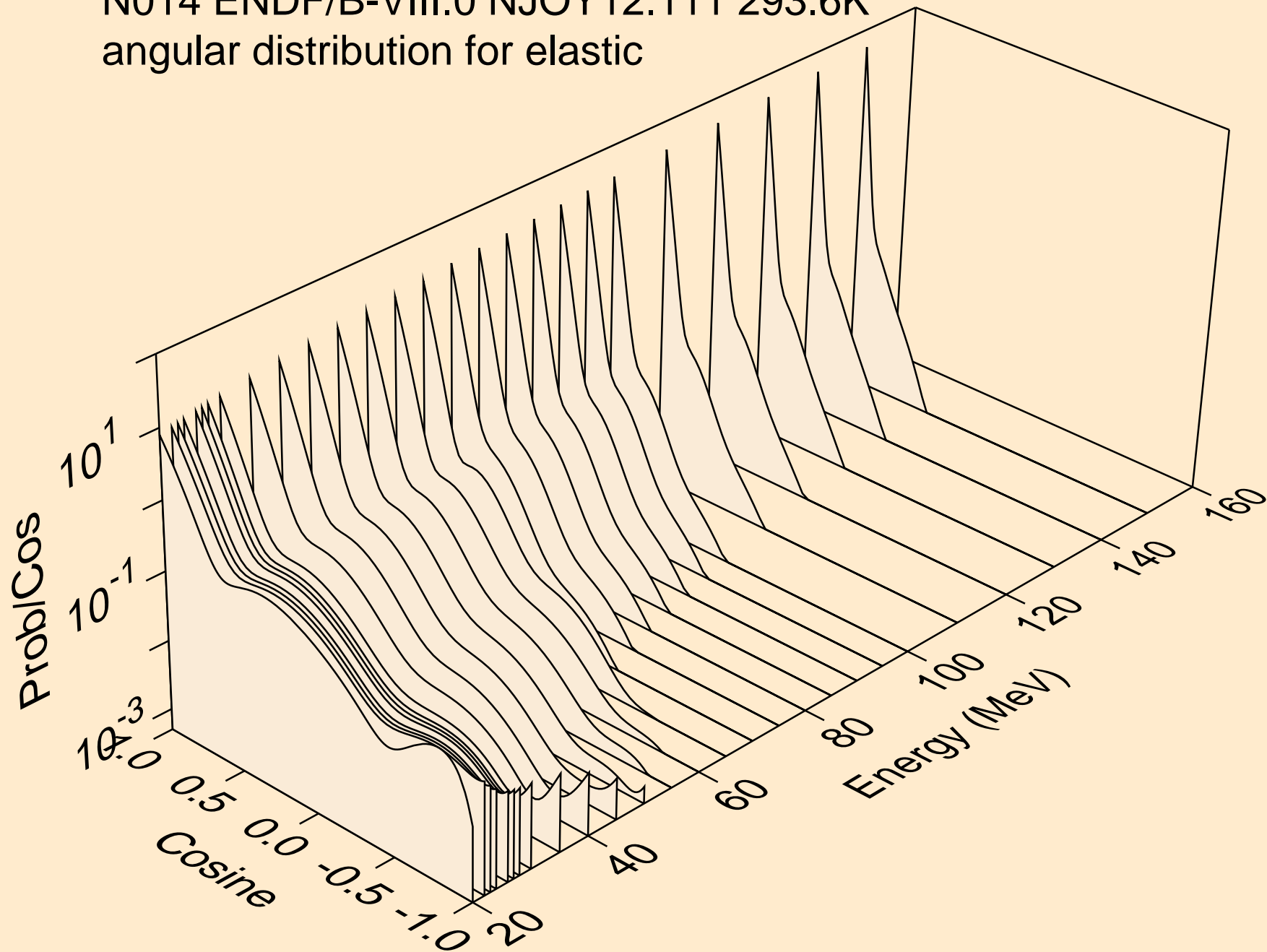

N014 ENDF/B-VIII.0 NJOY12.111 293.6K
angular distribution for (n,n*1)

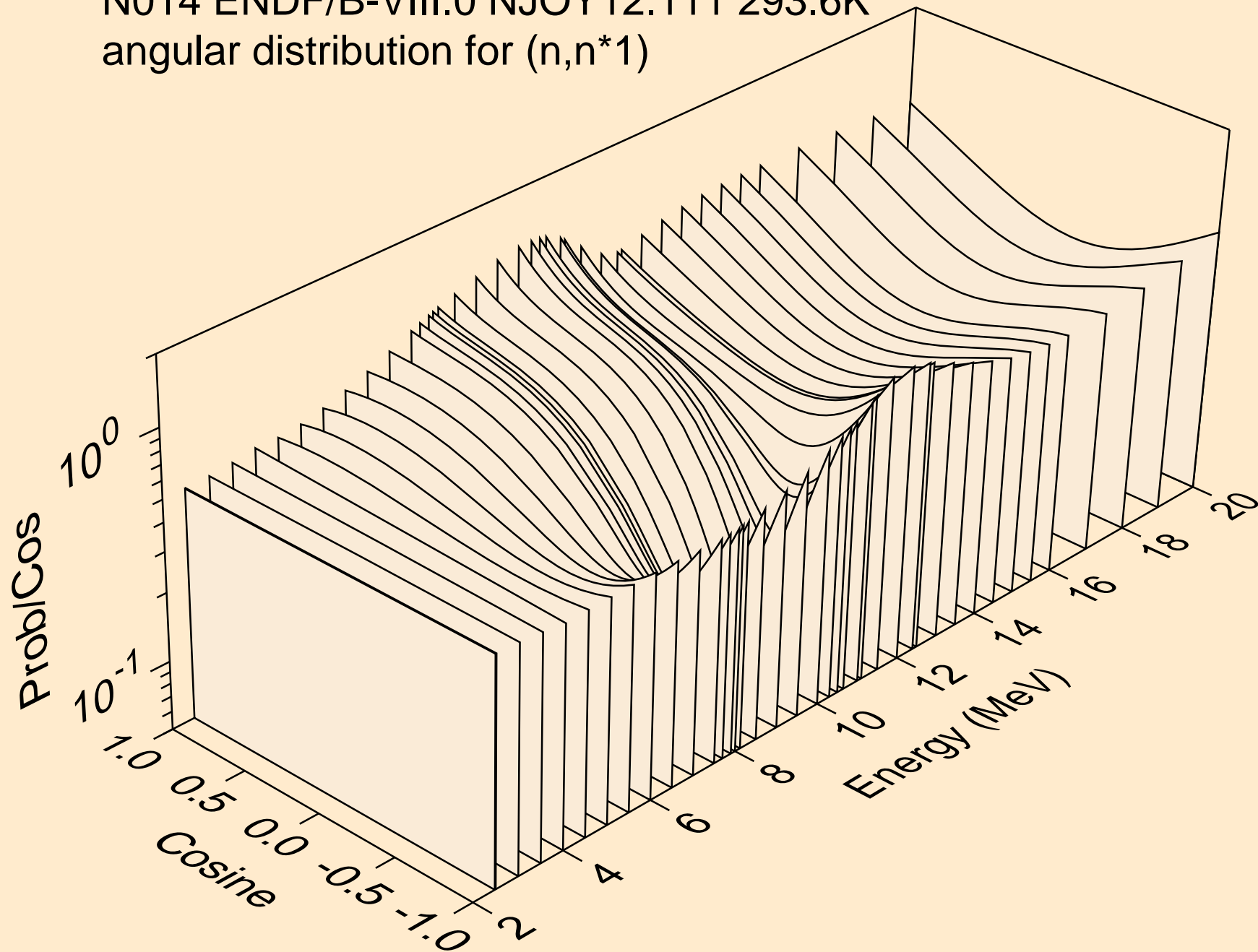

N014 ENDF/B-VIII.0 NJOY12.111 293.6K
angular distribution for (n,n*2)

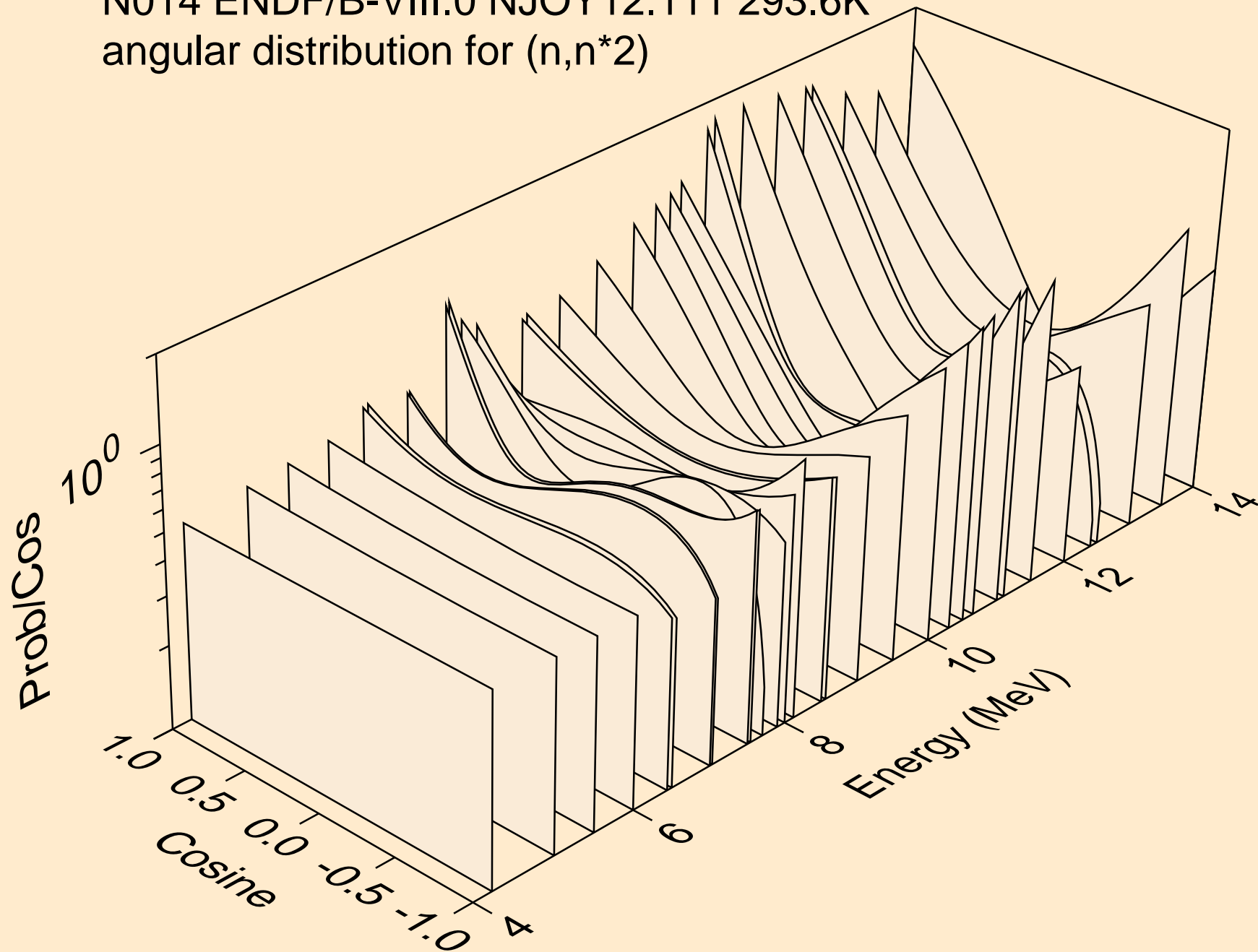

N014 ENDF/B-VIII.0 NJOY12.111 293.6K
angular distribution for (n,n*3)

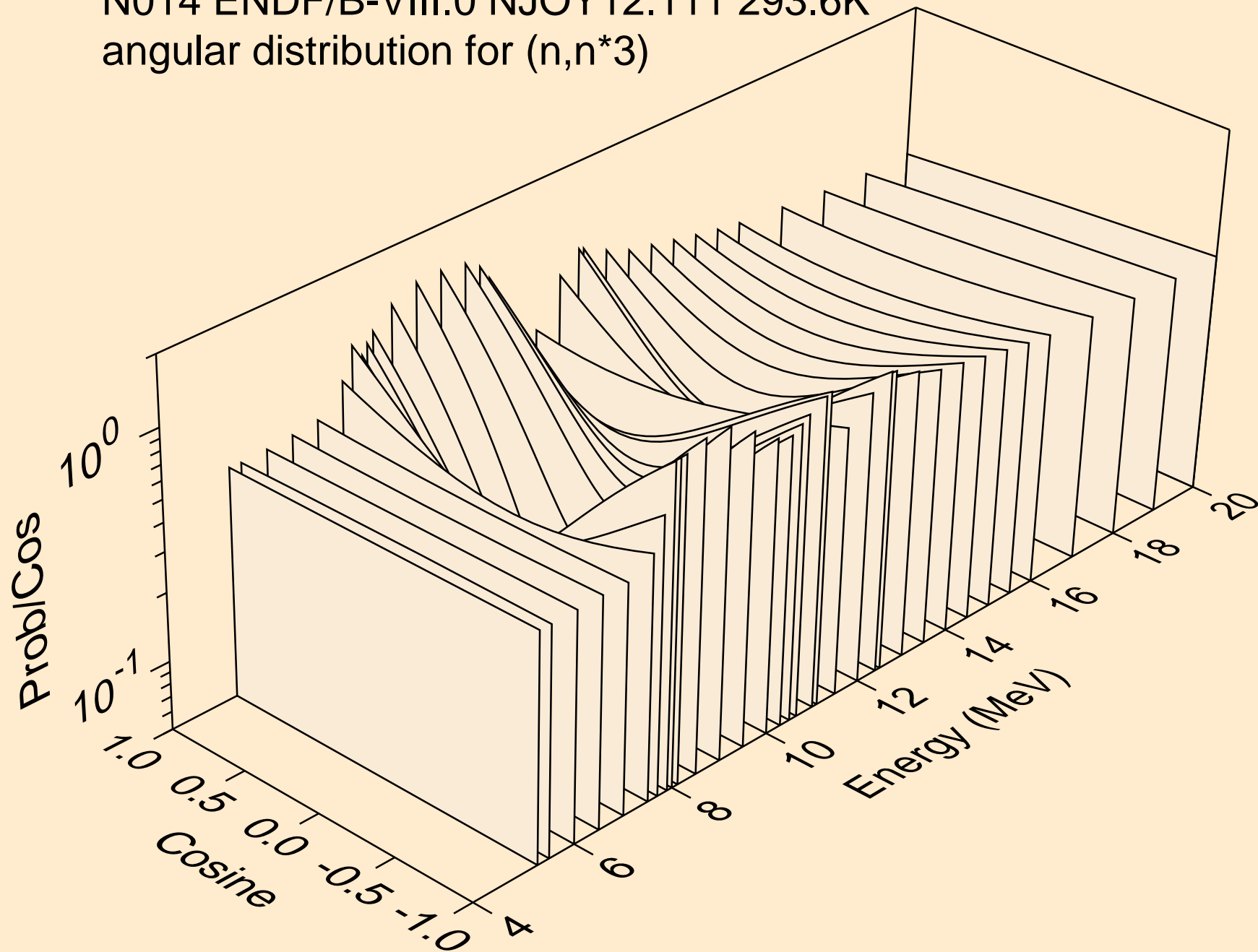

N014 ENDF/B-VIII.0 NJOY12.111 293.6K
angular distribution for (n,n*4)

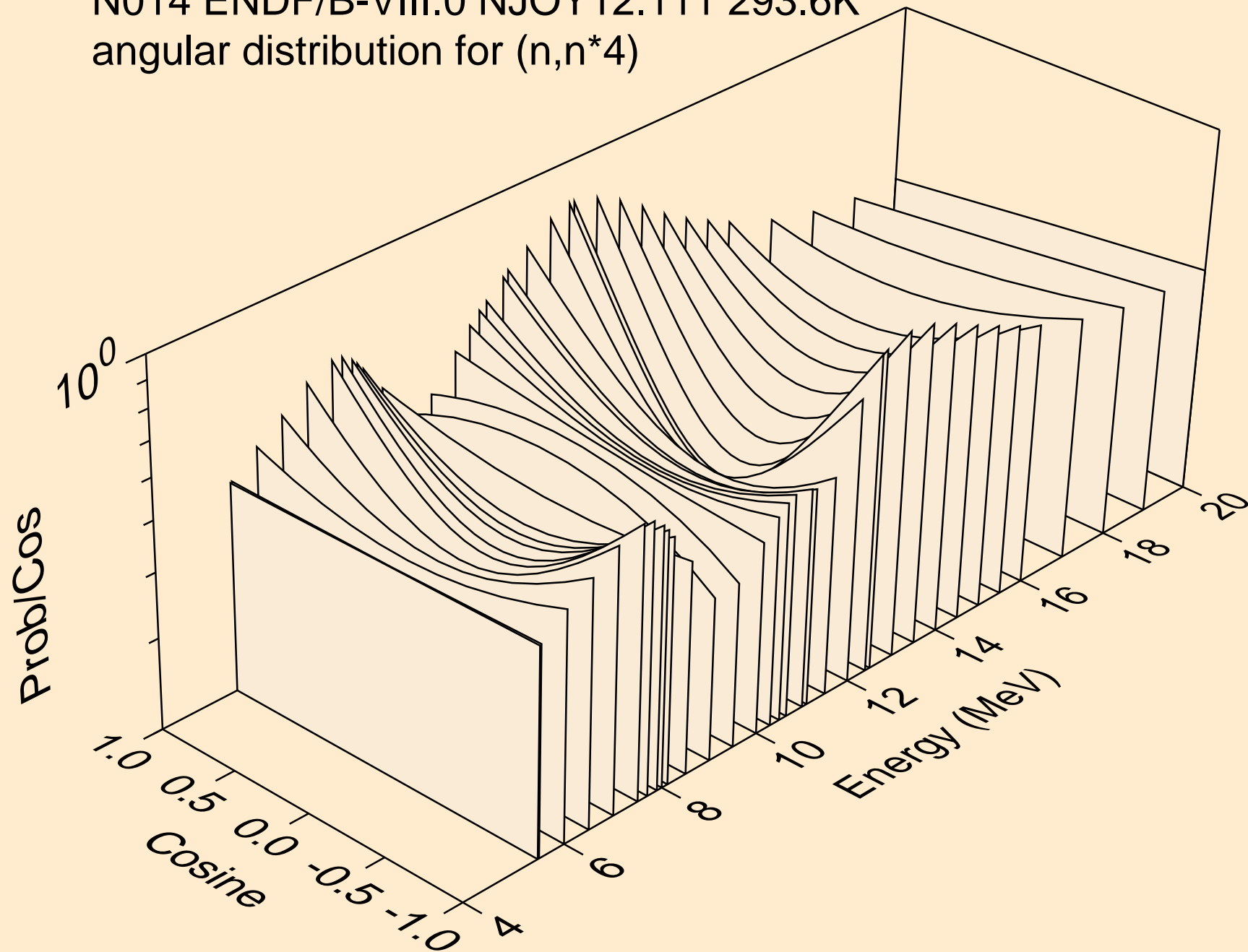

N014 ENDF/B-VIII.0 NJOY12.111 293.6K
angular distribution for (n,n*5)

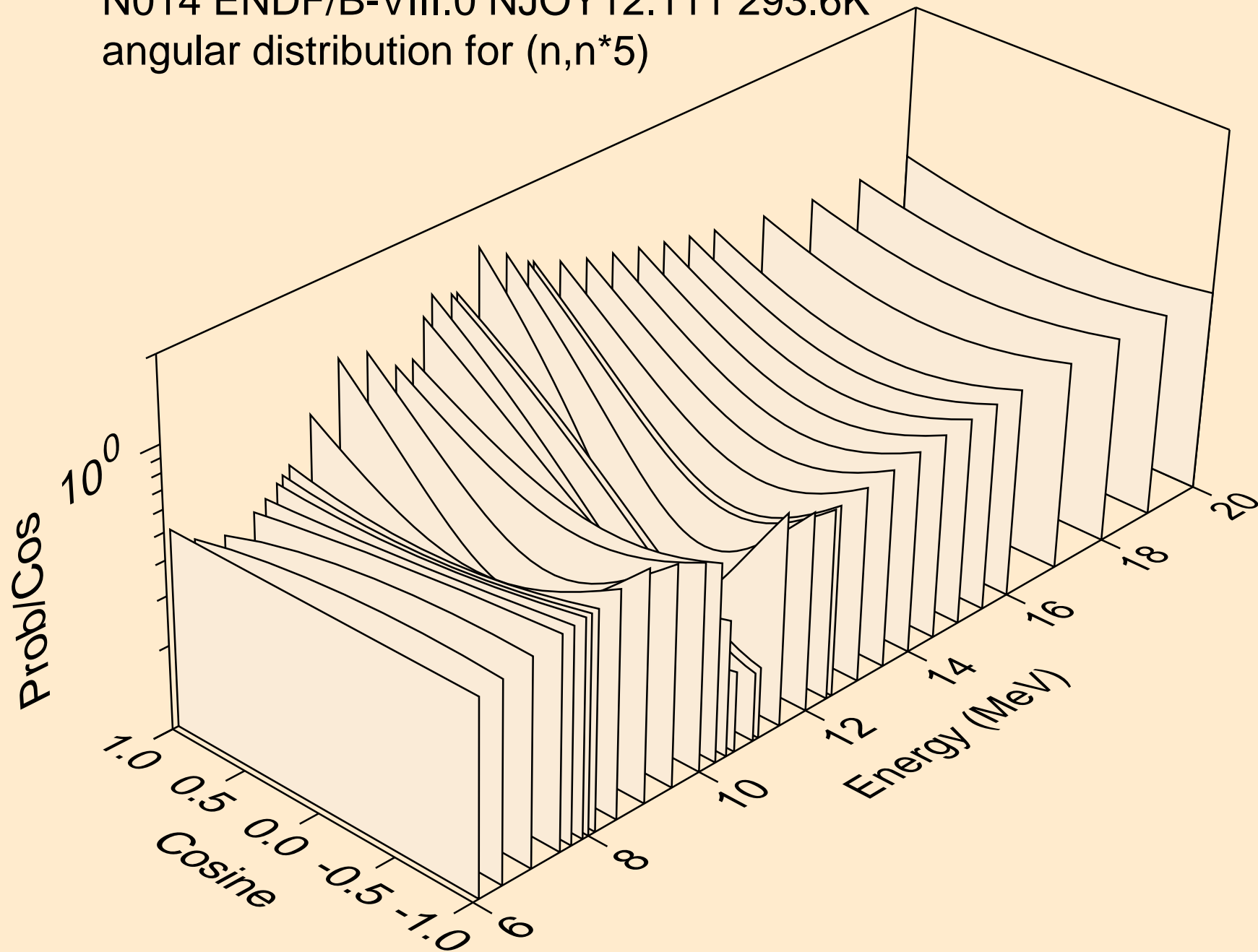

N014 ENDF/B-VIII.0 NJOY12.111 293.6K
angular distribution for (n,n*6)

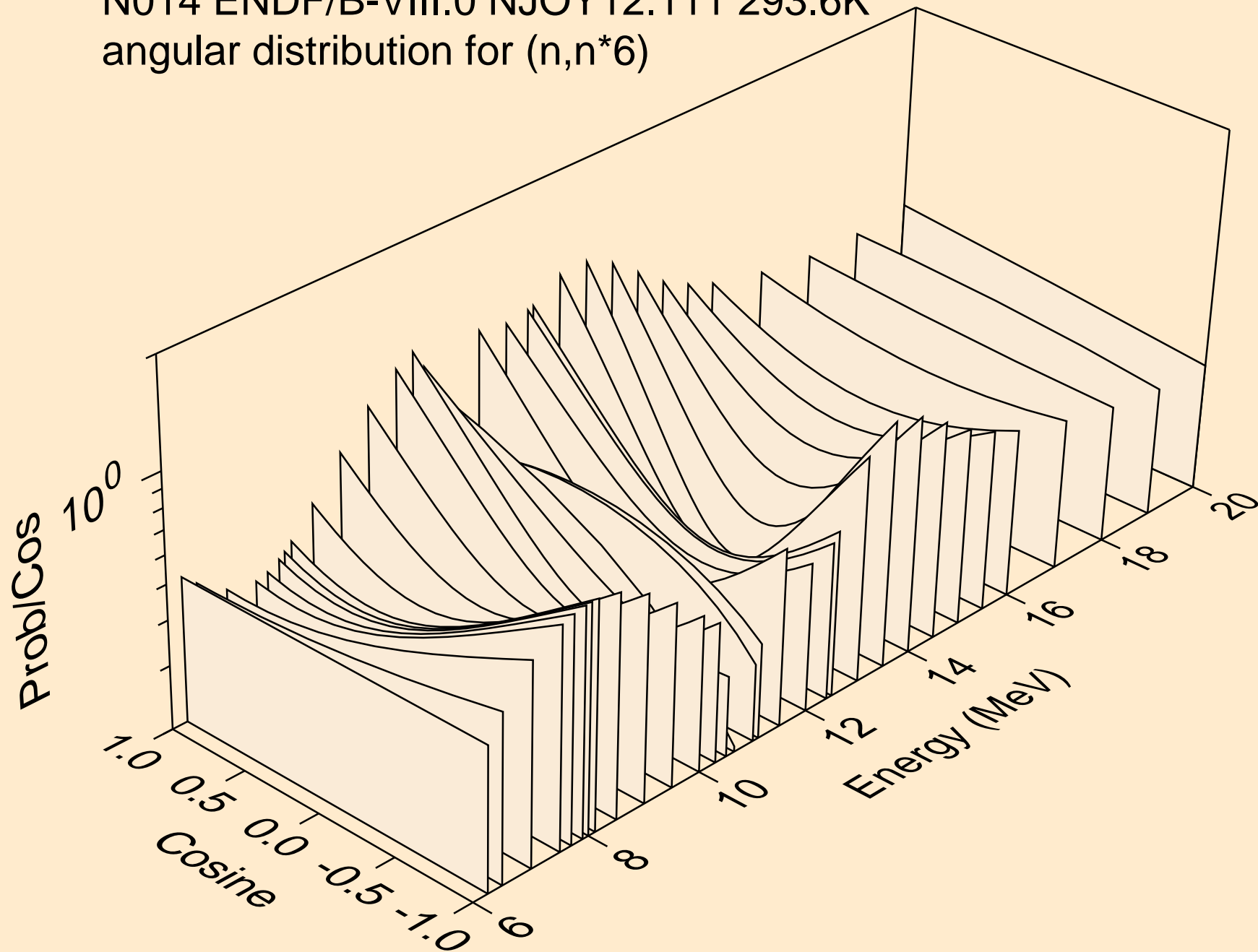

N014 ENDF/B-VIII.0 NJOY12.111 293.6K
angular distribution for (n,n*7)

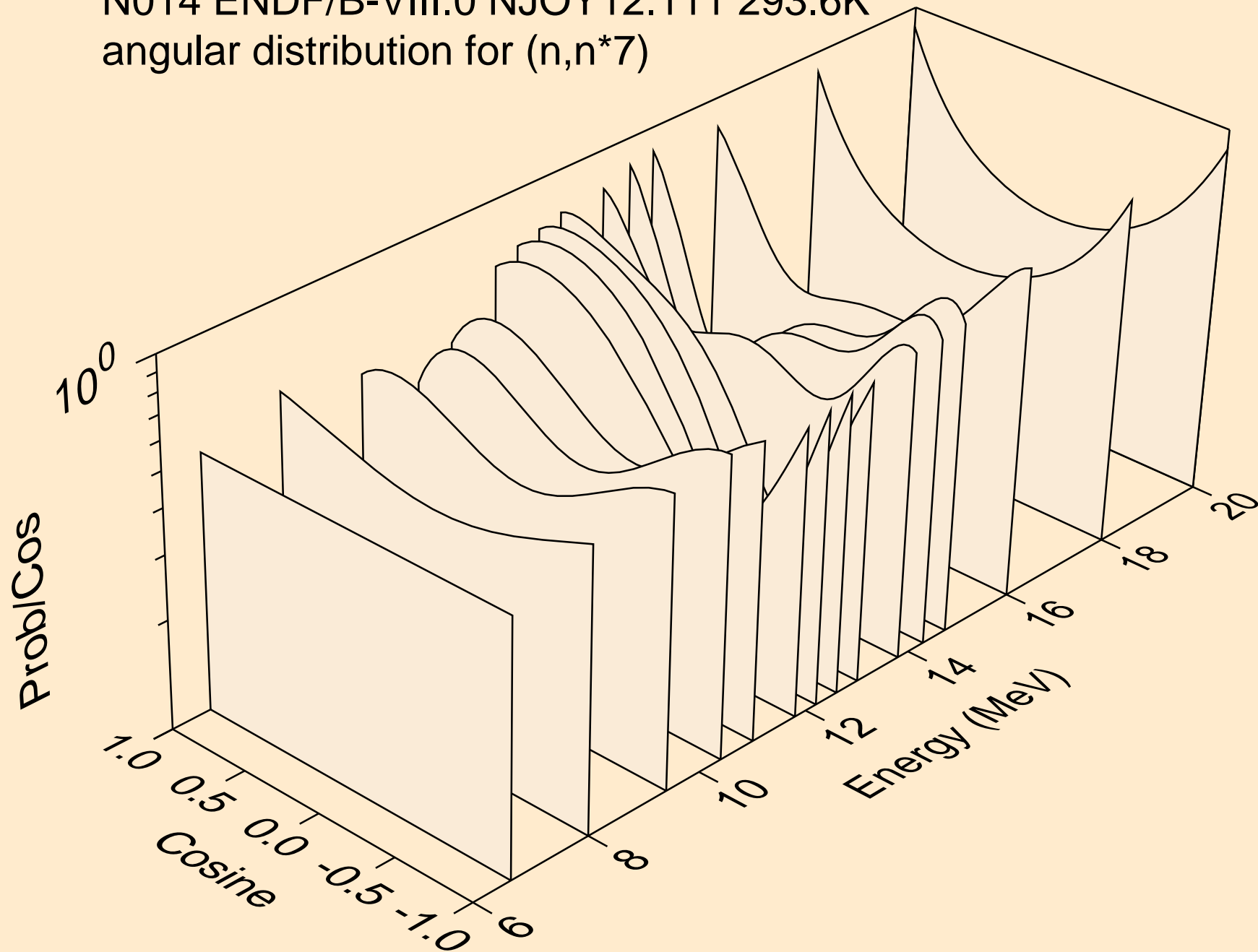

N014 ENDF/B-VIII.0 NJOY12.111 293.6K
angular distribution for (n,n*8)

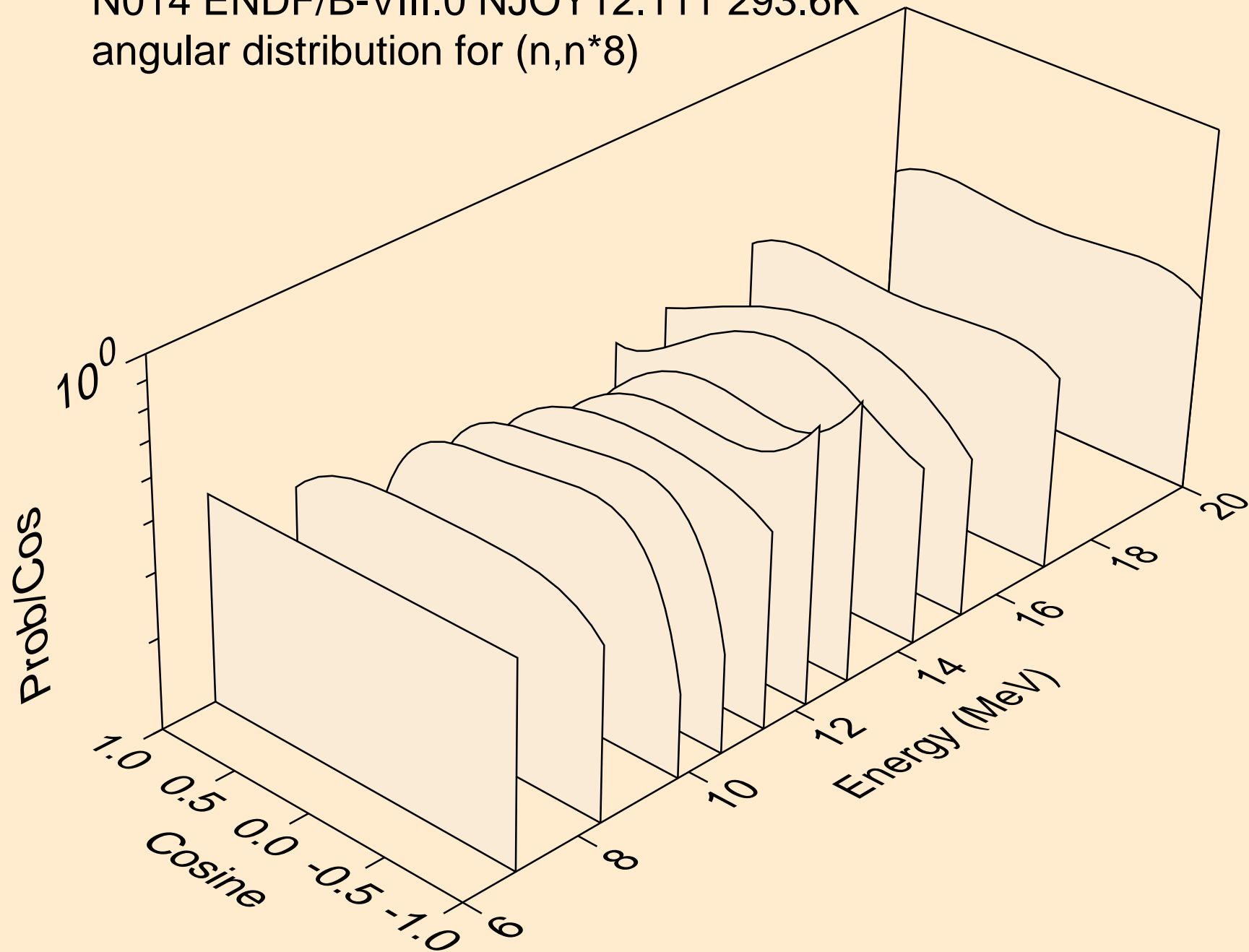

N014 ENDF/B-VIII.0 NJOY12.111 293.6K
angular distribution for (n,n*9)

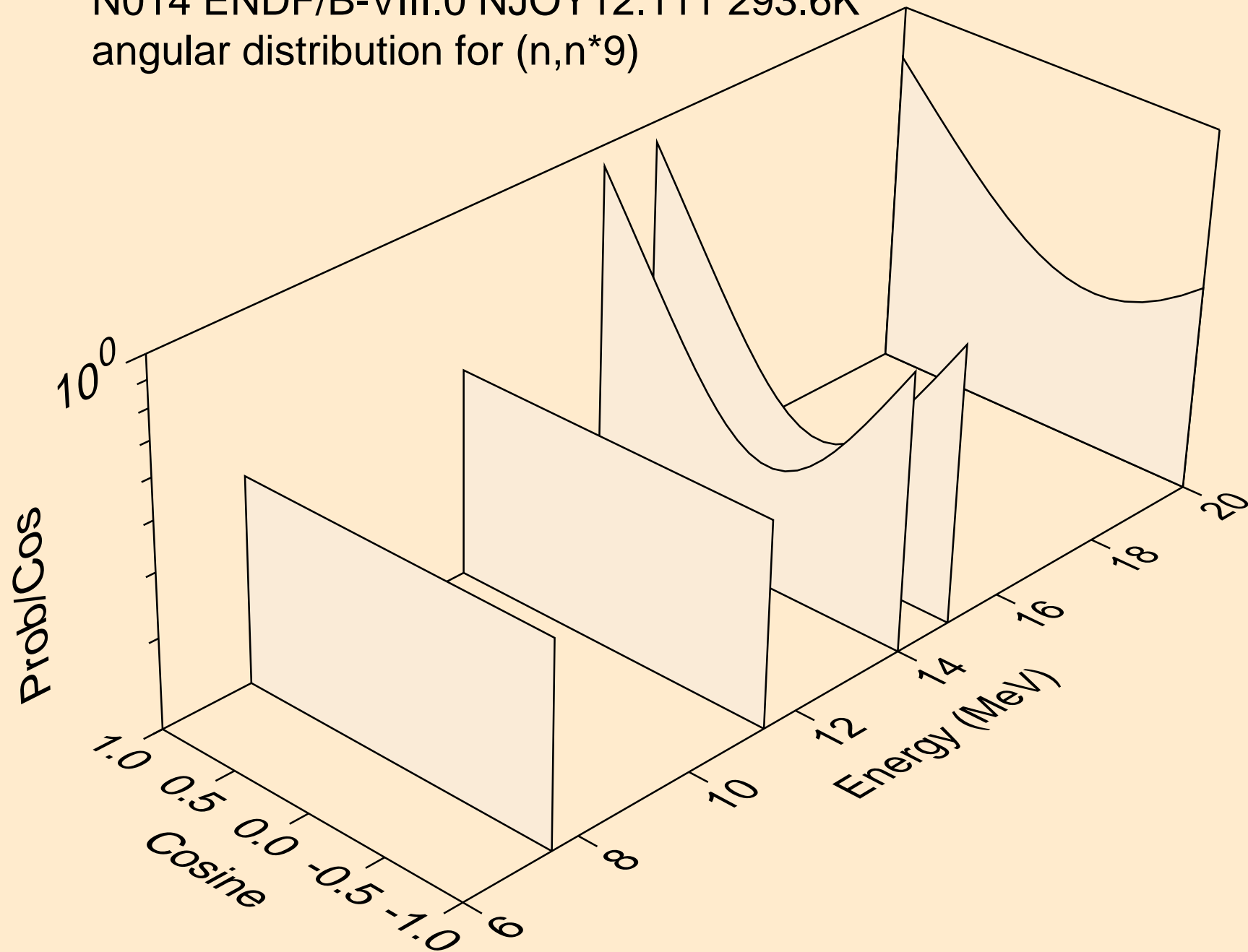

N014 ENDF/B-VIII.0 NJOY12.111 293.6K
angular distribution for (n,n*10)

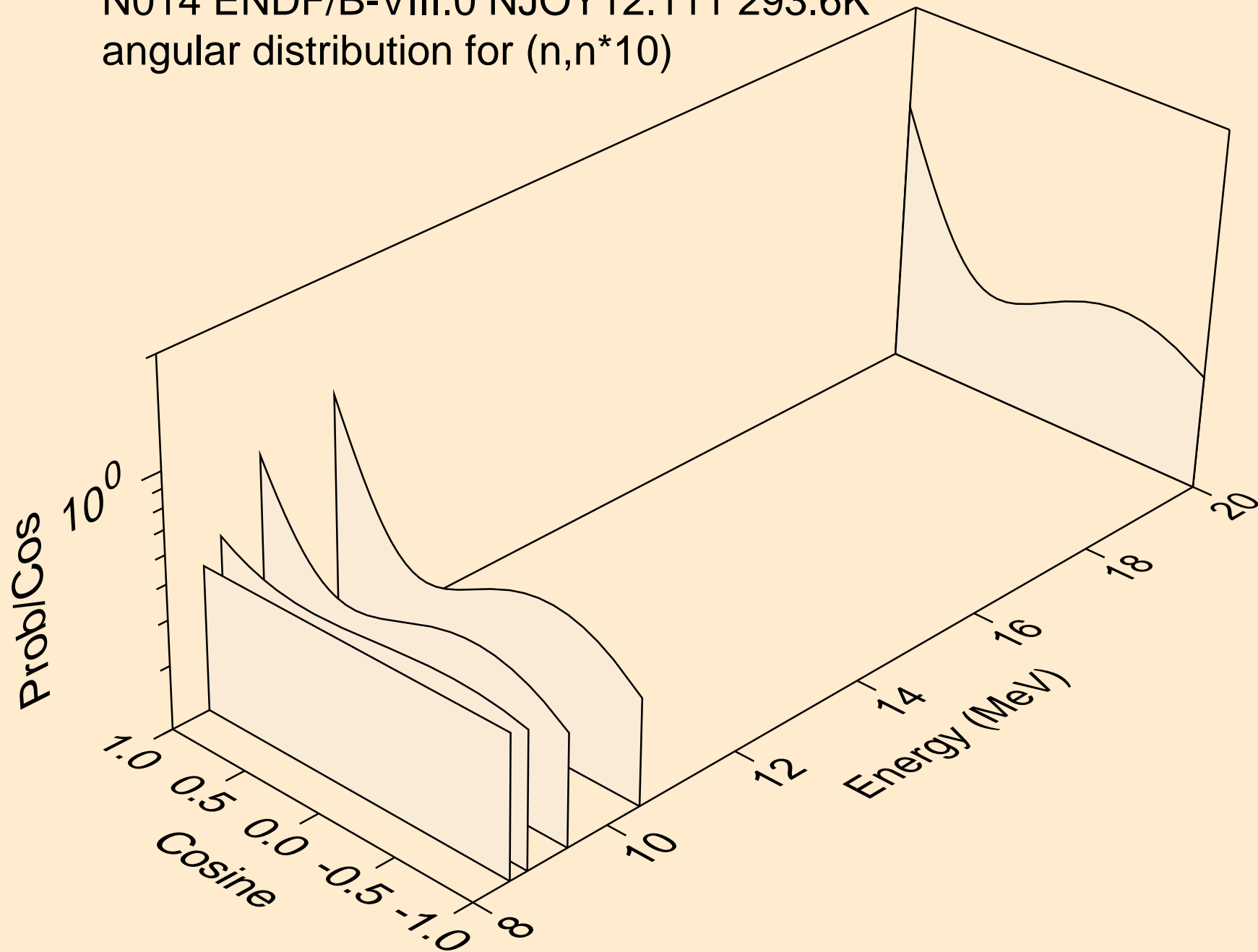

N014 ENDF/B-VIII.0 NJOY12.111 293.6K
angular distribution for (n,n*11)

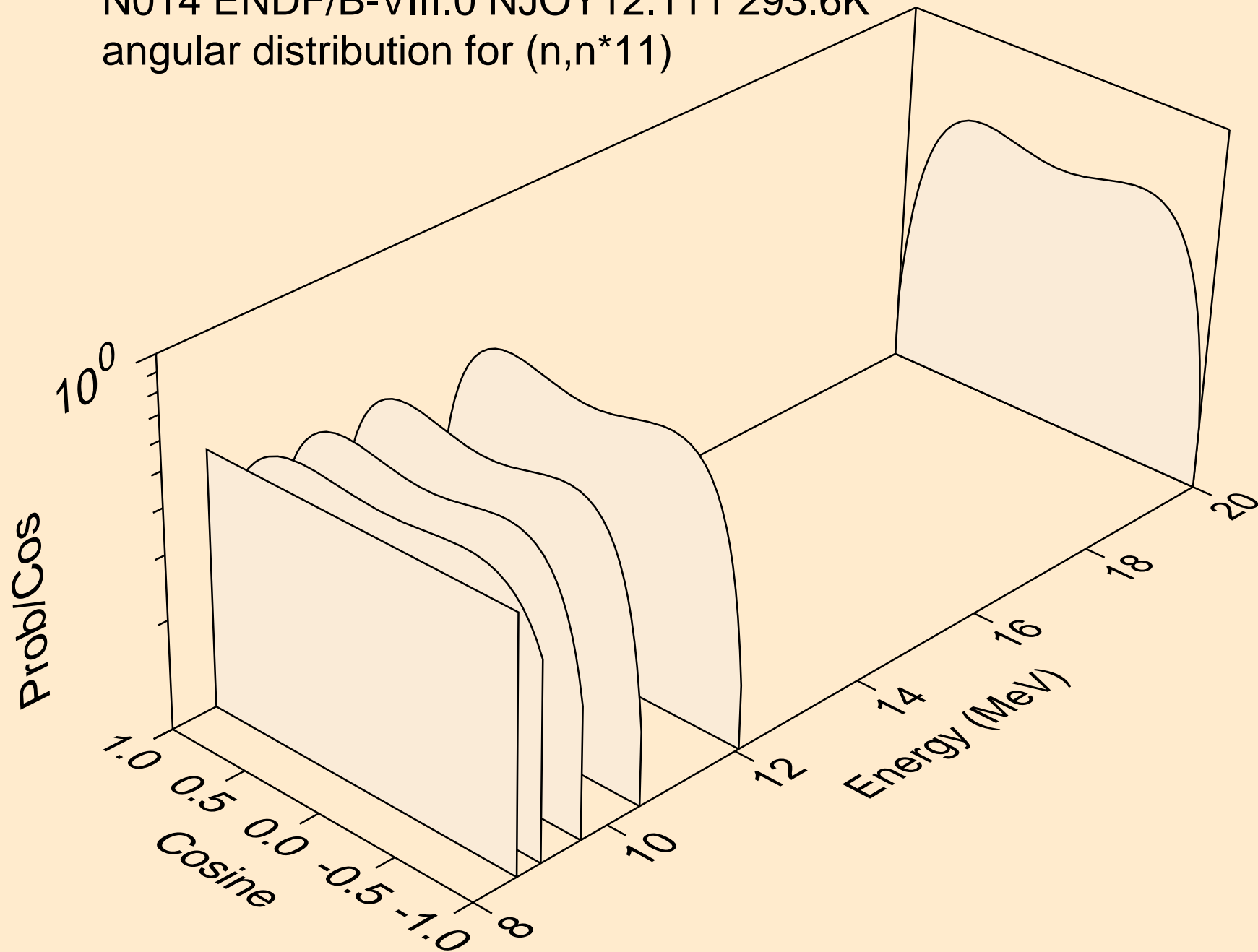

N014 ENDF/B-VIII.0 NJOY12.111 293.6K
angular distribution for (n,n*12)

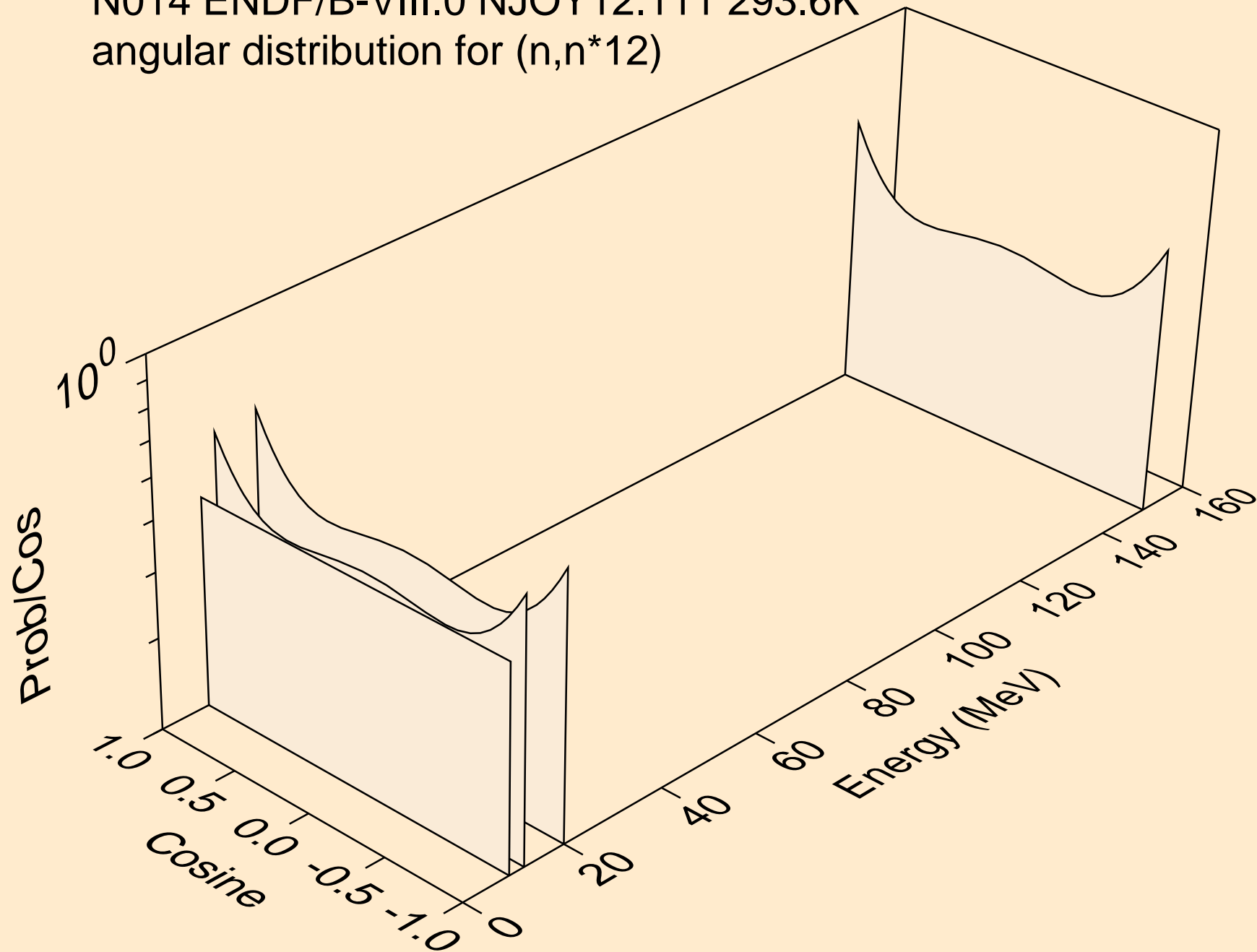

N014 ENDF/B-VIII.0 NJOY12.111 293.6K
Neutron emission for (n,x)

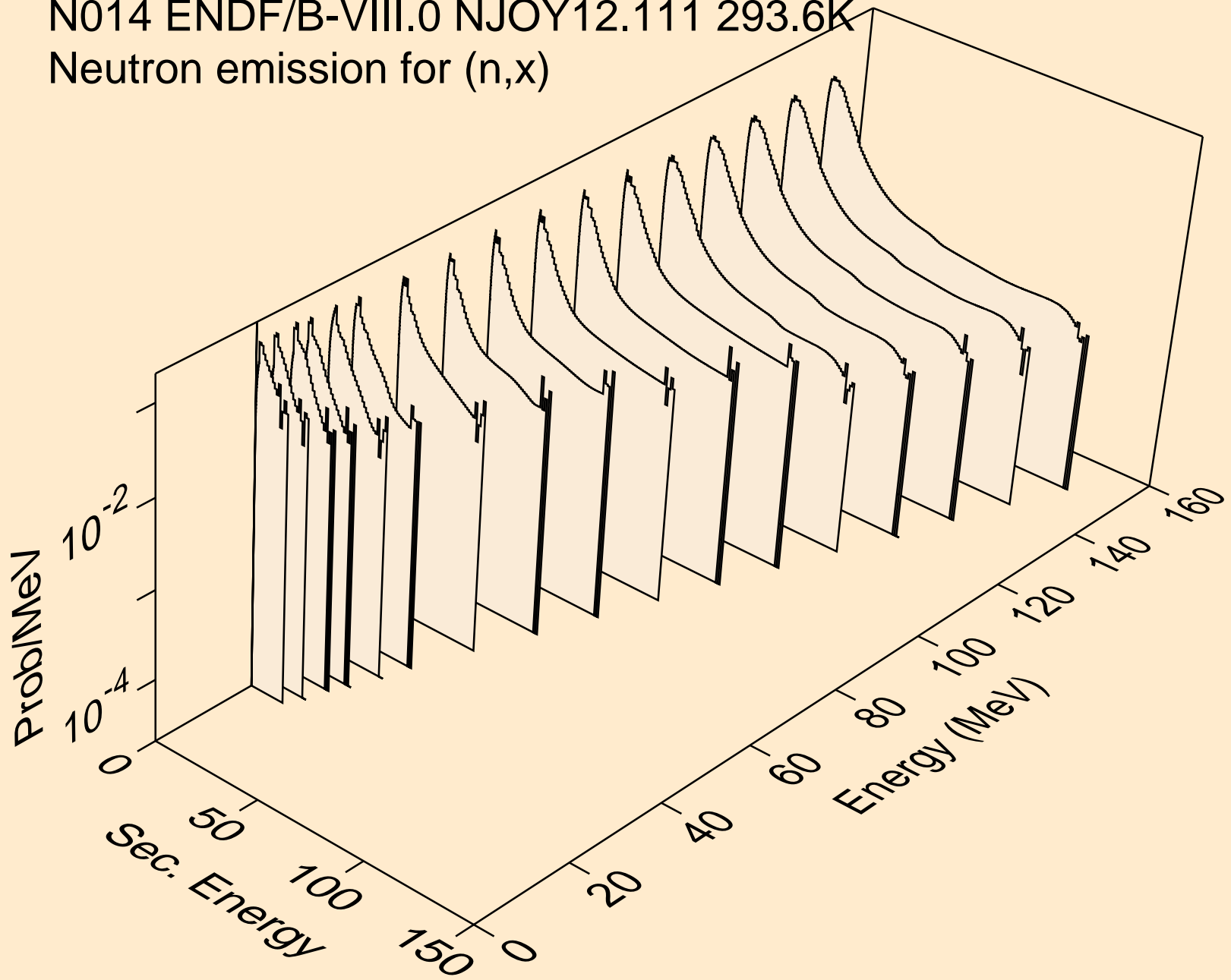

N014 ENDF/B-VIII.0 NJOY12.111 293.6K
Neutron emission for (n,2n)

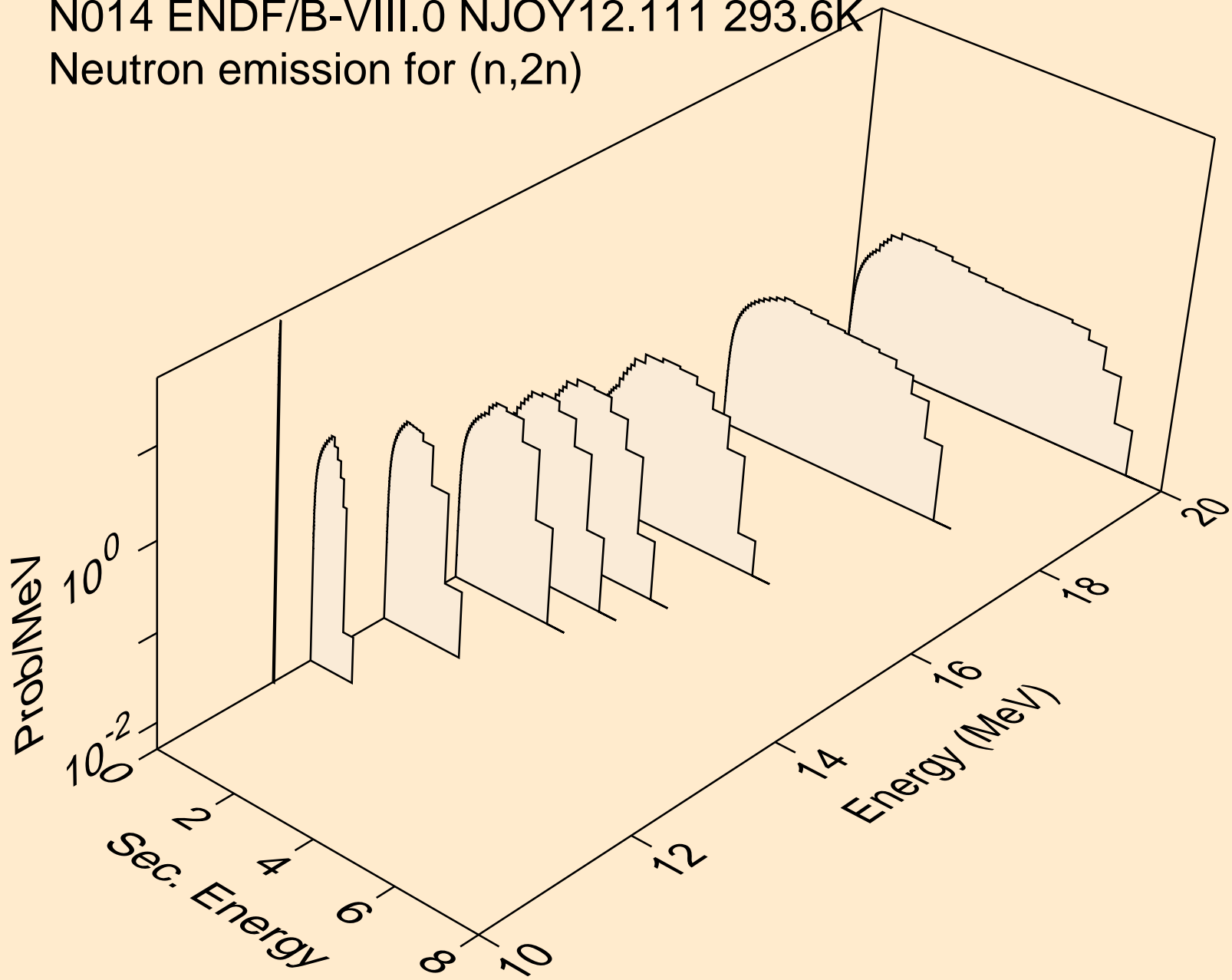

N014 ENDF/B-VIII.0 NJOY12.111 293.6K
Photon emission for (n,gma)

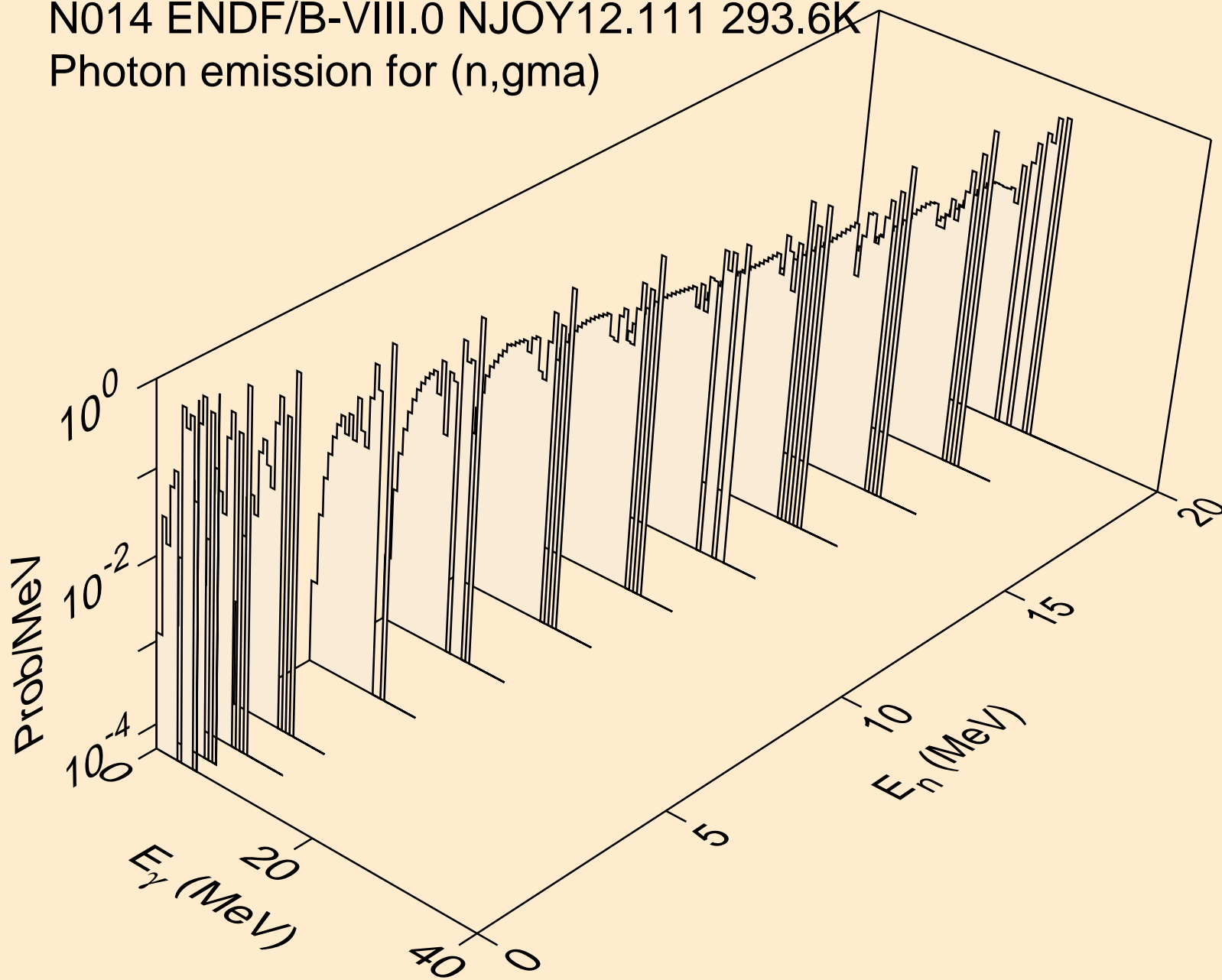

N014 ENDF/B-VIII.0 NJOY12.111 293.6K
Photon emission for (n,x)

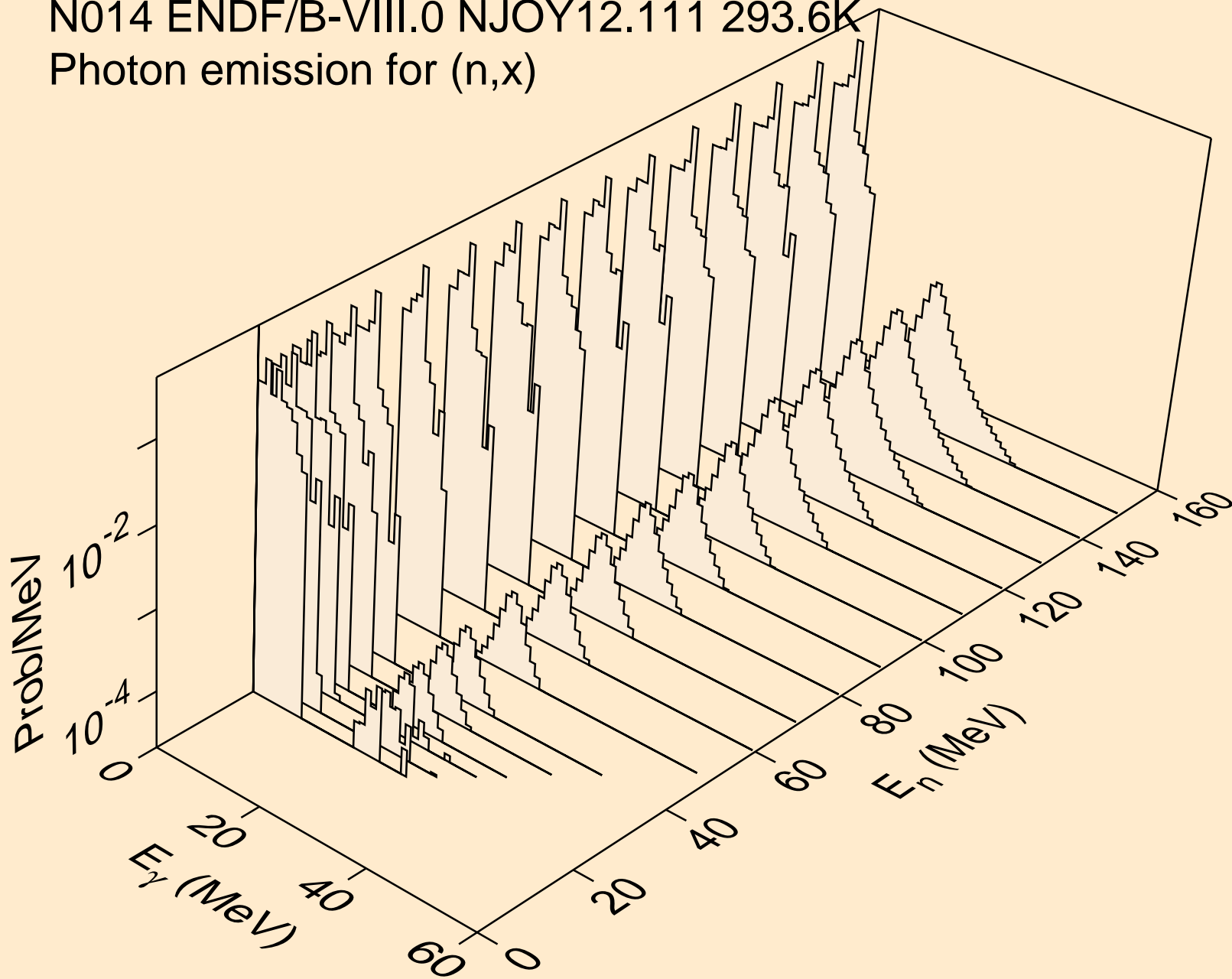

N014 ENDF/B-VIII.0 NJOY12.111 293.6K
thermal capture photon spectrum

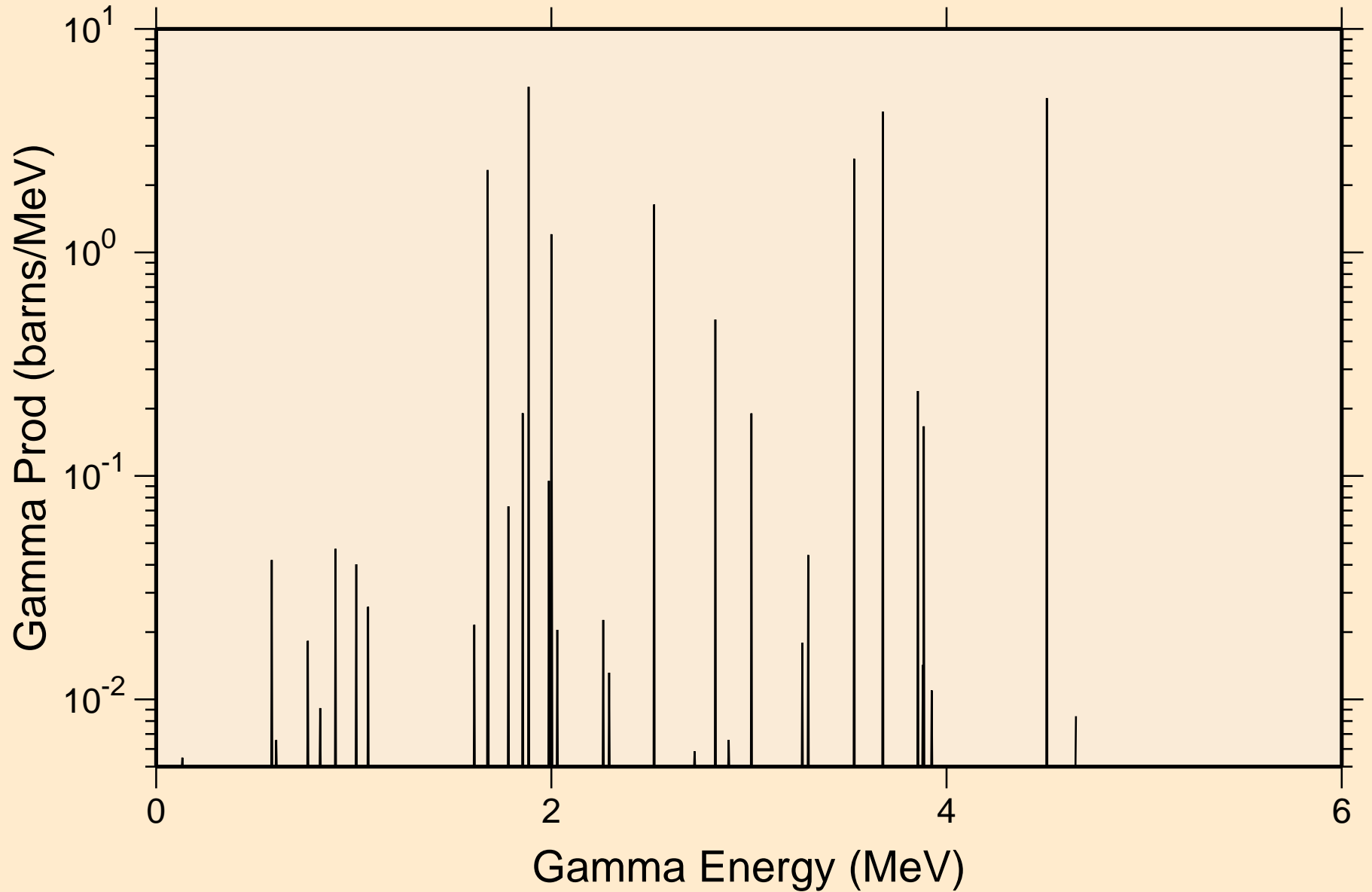

N014 ENDF/B-VIII.0 NJOY12.111 293.6K

14 MeV photon spectrum

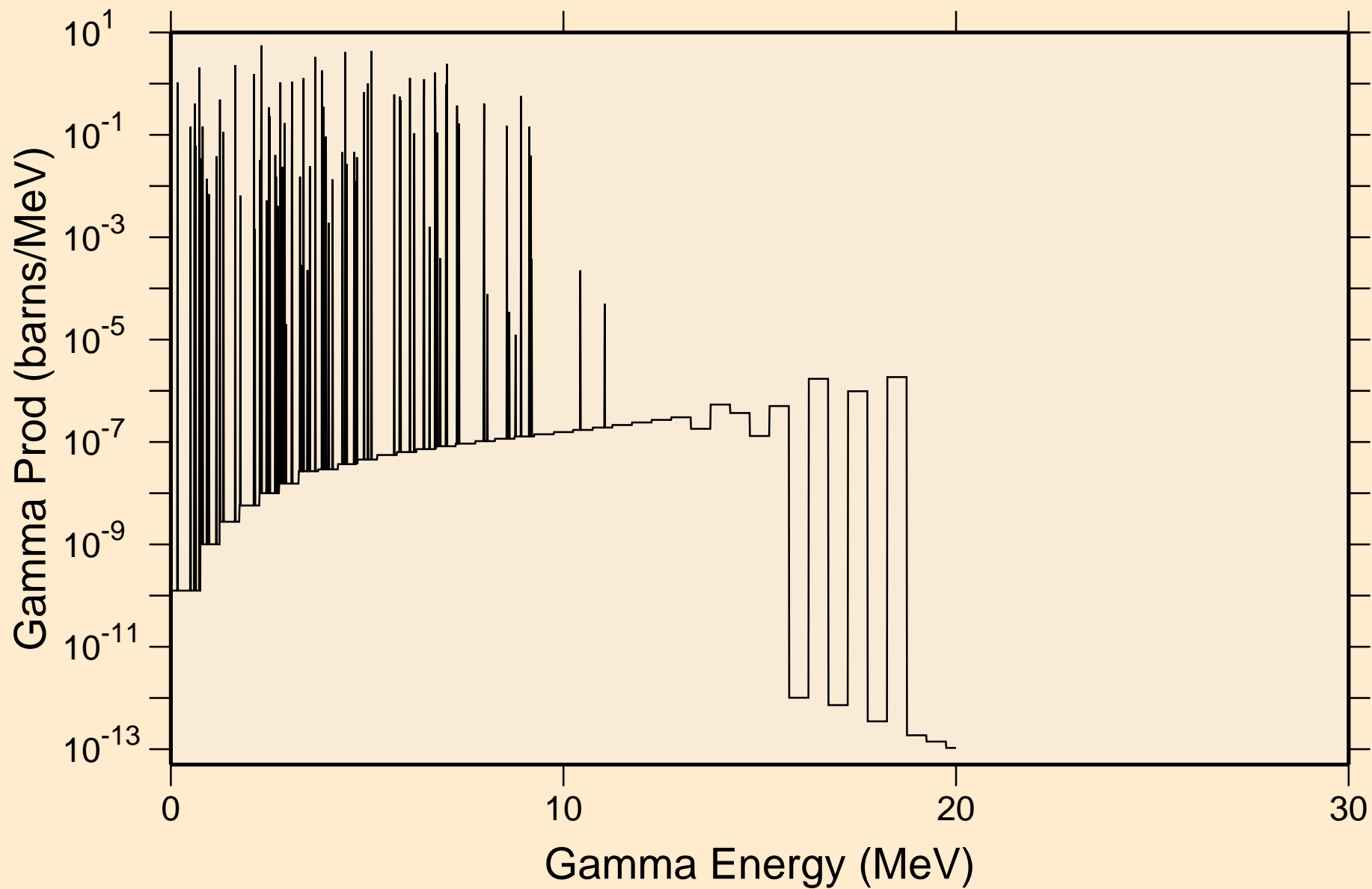

N014 ENDF/B-VIII.0 NJOY12.111 293.6K
Particle heating contributions

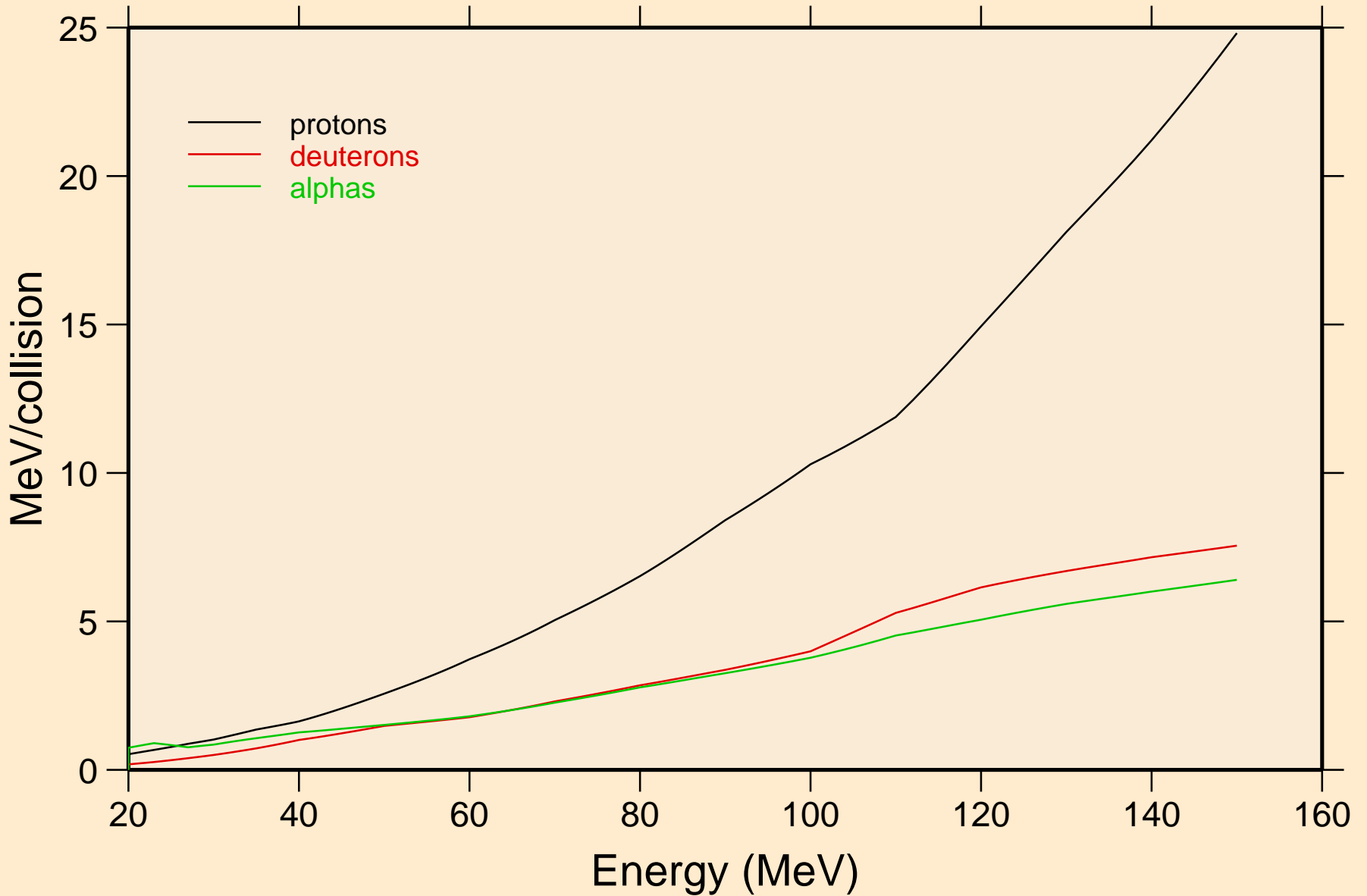

N014 ENDF/B-VIII.0 NJOY12.111 293.6K

Recoil Heating

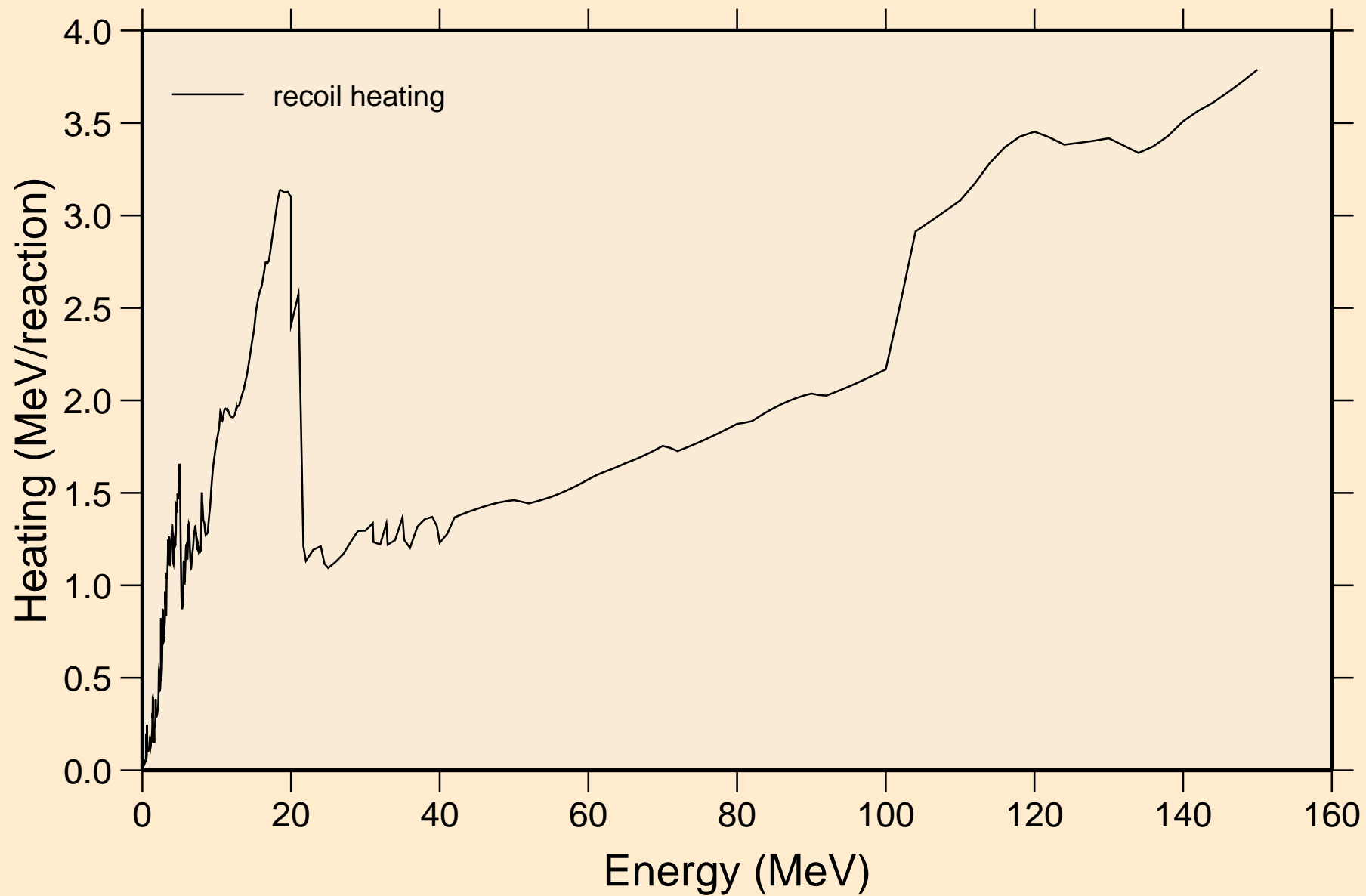

N014 ENDF/B-VIII.0 NJOY12.111 293.6K

Particle production cross sections

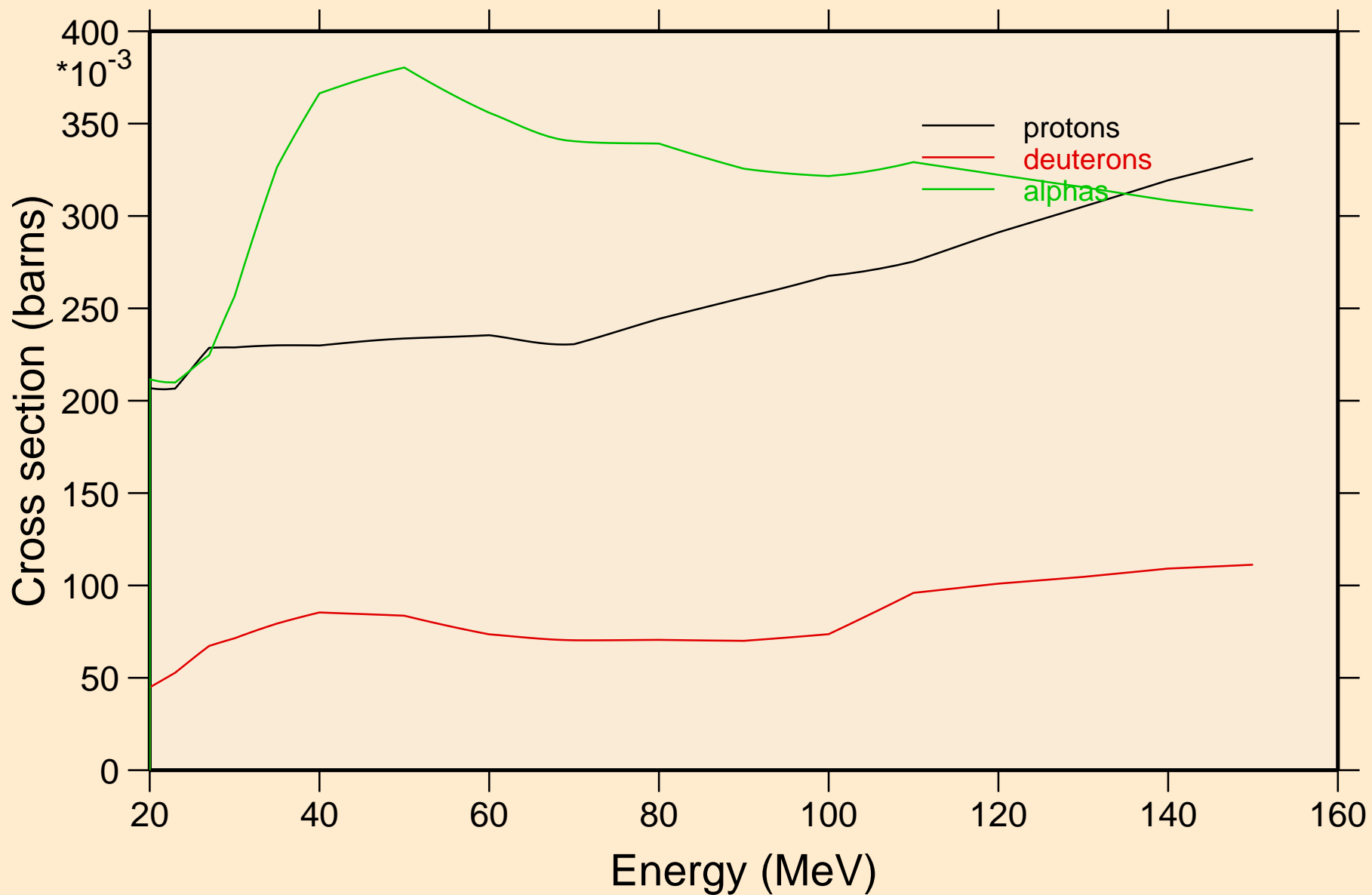

N014 ENDF/B-VIII.0 NJOY12.111 293.6K
protons from (n,x)

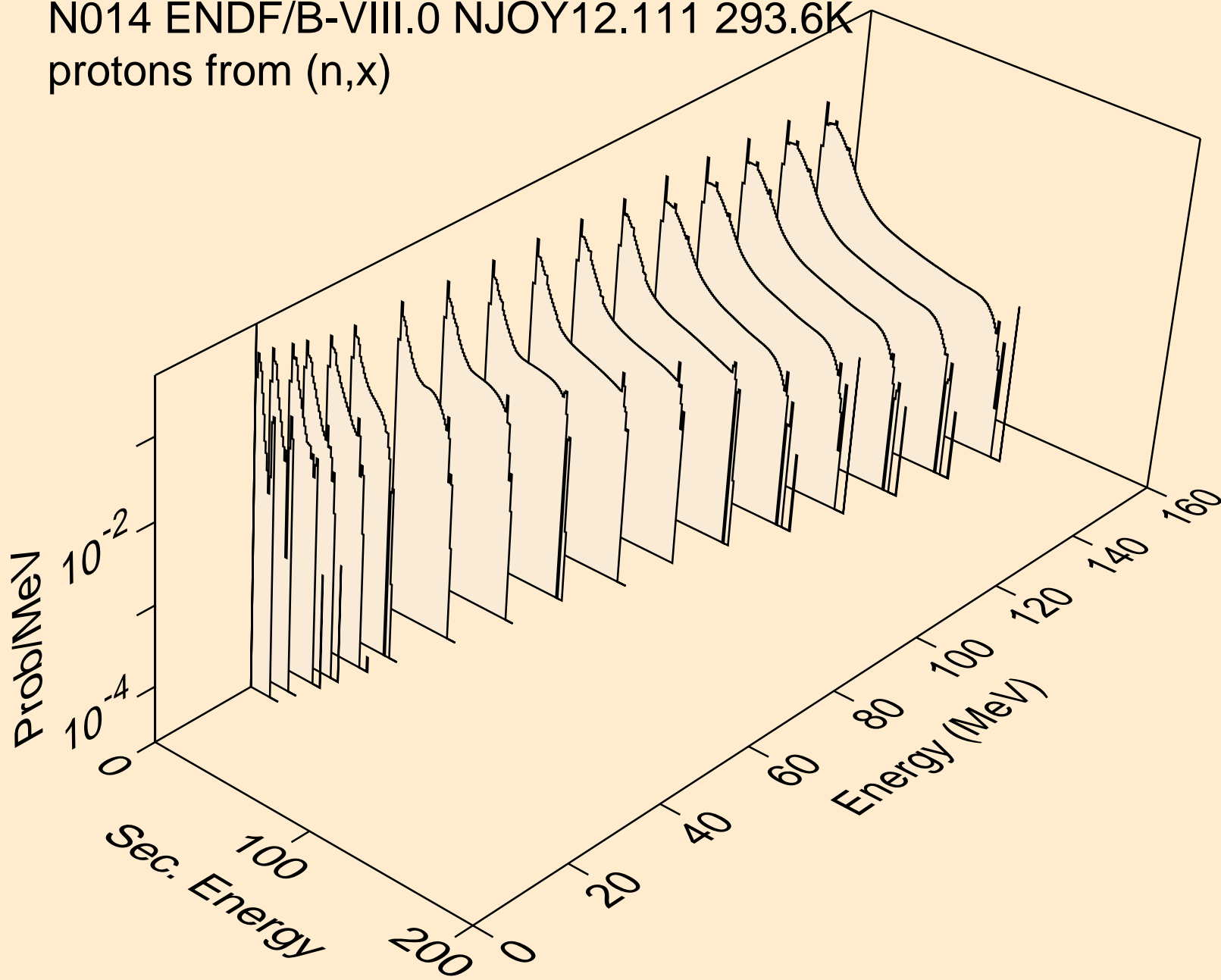

N014 ENDF/B-VIII.0 NJOY12.111 293.6K
deuterons from (n,x)

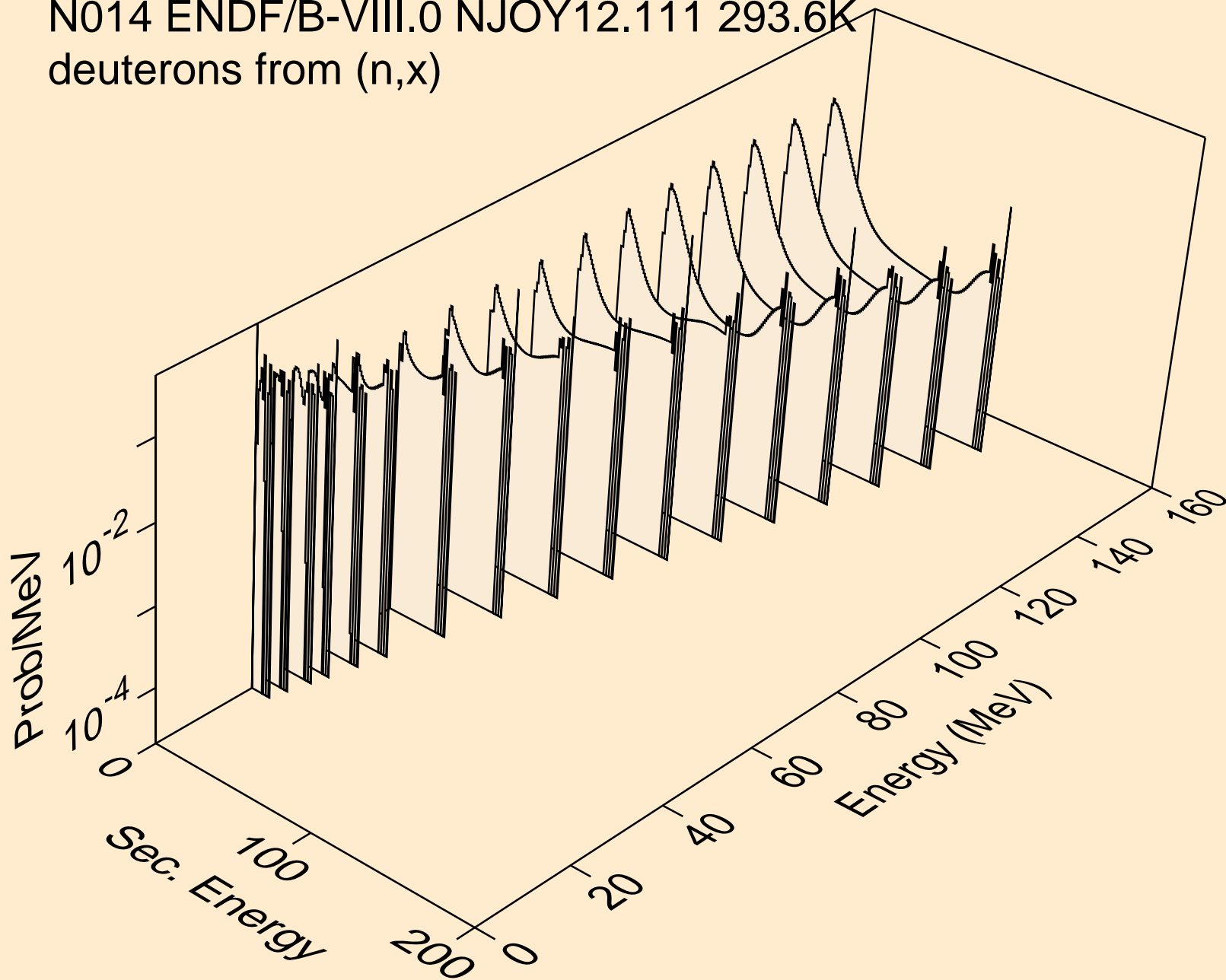

N014 ENDF/B-VIII.0 NJOY12.111 293.6K
alphas from (n,x)

