

Benthic and Resistivity Sensors (BARS)

User's Manual

Designed and Built for:

Marv Lilley (University of Washington)
Canadian Neptune Project

Designed and Built by:

Ocean. Engineering Services
University of Washington
Rex Johnson
Randy Fabro
Tor Bjorklund

Built: July, 2010
Last Update: July 18, 2012

----- TABLE OF CONTENTS -----

Section 1	Overall System Description Data Format Specifications
Section 2	Operating Instructions A. Preparations for Deployment B. User Operation Notes C. Scientific Event Detection D. Troubleshooting Notes E. Post Cruise Procedures
Section 3	Schematics
Section 4	Mechanical Drawings
Section 5	Notes

Section 1

Overall System Description



BARS System Overview

This instrument was specifically designed to be used on the Canadian underwater cable system commonly referred to as Neptune Canada. The full instrument name is “Benthic And Resistivity Sensors”. For convenience, the acronym is “BARS”. This instrument is a sophisticated underwater scientific sensor interface designed to take measurements from a multitude of sensors in hydrothermal vents and translate the sensor output signals via standard serial communications in useful scientific units. It has sensors to measure resistivity, temperature, eH (oxidizable nature of seawater components) & hydrogen. The heart of the data logger is an Onset Tattletale 8V2 microprocessor. This microprocessor controls power to the sensors, the data collection, formatting of data, data output streaming, and provides user interaction as needed. It is setup as a “plug and play” system in that once power is applied to the system, the Tattletale microprocessor automatically takes data according to preloaded user selected parameters and outputs the data to the cable system via RS422 protocol. The user can send a command to the BARS unit to stop data collection (double Control-S) and enter a Menu Mode where diagnostics can be run, data collection parameters can be changed, power to each sensor can be turned on or off, and data collection restarted. Under the parameter change menu in the software, the user can determine how often to sample the data, which sensors are energized, and whether the system Metadata and Parameters are outputted pm power up and/or restart of data collection. All the user parameters are stored in Eprom memory so they do not need to be reloaded each time the unit is powered back up.

The Tattletale 8V2 Data Logger/Controller Microprocessor lives in a Titanium pressure case, which can be deployed for extended periods of time without concern. The Tattletale 8V2 is programmed in TxBasic (Version 5). TxBasic is very simple, yet powerful. All communications with the Logger/Controller are via standard RS422 protocol at 9600 baud. This system is supplied with a fully operational program (BARS.TXB) for taking the data. This software provides the user with the ability to select parameters, do diagnostics, and collect data based on the operator’s selected parameters, all with user friendly menus. This program also does automatic error checking such as verifying that any user entered parameters are within proper tolerances without conflicts, and even stops the automatic logging if the power to the device drops below the acceptable tolerance, since all data below that point is invalid. This program is preloaded in permanent memory and automatically runs when power is applied to the system.

The system is designed to be operated on the Canadian underwater cable system. It expects the input power to be 15 volts but it can operate properly with an input voltage as low as 13 volts or as high as 30 volts dc. The system outputs serial data to the cable system using RS422 protocol at user defined time intervals from 15 seconds to 60 minutes. An example of the output data is shown on the next page with the formatting of that data shown on the following page.

Sample of Typical BARS Data Stream shown with optional Metadata
(12 words per burst)
(See next page for details)

System Name: BARS (Benthic and Resistivity Sensors)
System Owner: Marv Lilley, University of Washington
Owner Contact Phone #: 206-543-0859
System Serial #: 001
Software Version 1.86, Last Update March 28, 2012
Made by Ocean Engineering Service, July 2010 (206-543-9688)

This system is presently setup with the following parameters:

- 1 = Eprom Status (0 means not setup yet, 1 means ready to use)
- 20 = Cycle Time (Actual time in seconds or minutes)
- 0 = Minutes or seconds Cycle Time (0 = seconds mode, 1 = minutes mode)
- 55 = Power Control Word (Power Control Word = 1 + 2 + 4 + 16 + 32 = 55 if all on)
- 1 = Res Power Status (0 = Off, 1 = On)
- 1 = Thermocouple & Hydrogen Amp Power Status (0 = Off, 1 = On)
- 1 = eH Amp Power Status (0 = Off, 1 = On)
- 1 = Hydrogen Sensor Power Status (0 = Off, 1 = On)
- 1 = Reference Temperature Power Status (0 = Off, 1 = On)
- 0 = Metadata Print Status on Power Up (0 = No print on Power up, 1 = Print)
- 0 = Metadata Print Status on Restart Data Collection (0 = No print, 1 = Print)

0.065	0.338	1.660	0.123	0.637	3.201	1.994	1.877	3.53	1.284	318.1	9.1
0.066	0.337	1.660	0.122	0.639	3.200	1.993	1.877	3.53	1.283	317.8	9.1
0.067	0.337	1.660	0.123	0.638	3.200	1.993	1.878	3.51	1.283	317.8	9.1
0.067	0.337	1.659	0.122	0.642	3.200	1.993	1.877	3.53	1.283	317.8	9.1
0.067	0.335	1.662	0.120	0.638	3.199	1.995	1.875	3.57	1.284	318.1	9.1
0.067	0.336	1.659	0.123	0.638	3.198	1.993	1.878	3.51	1.283	317.8	9.1
0.068	0.335	1.660	0.121	0.641	3.198	1.994	1.876	3.55	1.283	317.8	9.1
0.067	0.337	1.660	0.122	0.639	3.199	1.993	1.878	3.51	1.283	317.8	9.1
0.068	0.334	1.660	0.121	0.639	3.198	1.994	1.874	3.59	1.284	318.1	9.1
0.067	0.335	1.665	0.120	0.639	3.199	1.995	1.874	3.59	1.282	317.6	9.1
0.065	0.337	1.657	0.123	0.637	3.200	1.994	1.876	3.55	1.283	317.8	9.1
0.067	0.338	1.657	0.122	0.639	3.199	1.993	1.877	3.53	1.283	317.8	9.1
0.066	0.336	1.654	0.125	0.639	3.199	1.993	1.878	3.51	1.283	317.8	9.1
0.068	0.335	1.660	0.121	0.641	3.197	1.994	1.876	3.55	1.283	317.8	9.1
0.067	0.337	1.659	0.123	0.639	3.199	1.994	1.878	3.51	1.284	318.0	9.1
0.066	0.337	1.657	0.123	0.639	3.199	1.994	1.878	3.51	1.284	318.0	9.1
0.068	0.334	1.657	0.121	0.642	3.196	1.994	1.876	3.55	1.283	317.8	9.1
0.065	0.338	1.658	0.123	0.637	3.200	1.994	1.877	3.53	1.283	317.8	9.1
0.065	0.337	1.659	0.123	0.637	3.200	1.995	1.877	3.53	1.283	317.8	9.1

BARS Data Format

BARS Outputted Data Format using BARS.TXB Program:

The following is the Data Format for each burst: (12 Words/burst). The time between bursts is user selectable from 15 seconds to 60 minutes.

Word 1	Resistivity/5 (See Note 1)
Word 2	Resistivity X1 (See Note 1)
Word 3	Resistivity X5 (See Note 1)
Word 4	Hydrogen/5 (See Note 1)
Word 5	Hydrogen X1 (See Note 1)
Word 6	Hydrogen X5 (See Note 1)
Word 7	Eh Sensor (See Note 1)
Word 8	Reference Temp Volts (1) (2)
Word 9	Reference Temp Deg C
Word 10	Resistivity Temp Volts (1) (3)
Word 11	Resistivity Temp Deg C
Word 12	Battery Voltage (See Note 1)

Notes:

1. This data is outputted in volts.
2. The Reference Thermistor voltage must be translated into Degrees C based on the tables included in the NOTES and the SCHEMATICS sections of this manual. The Program BARS.TXB uses the equation: $T_m(\text{deg C}) = 27.50133 - 17.2658 * V + 15.83424 / V$ (V = Tm volts)
3. The Thermocouple voltage must be translated into Degrees C based on the tables included in the NOTES and the SCHEMATICS sections of this manual. The Program BARS.TXB uses the equation: $T_c(\text{deg C}) = (244970 * V) / 1000$ (V = Tc volts). The Final Corrected Temperature = Tm + Tc. The outputted voltage is just that of the sensor. The outputted temperature has been corrected with the reference.

BARS Specifications

Main Control Unit & Data Logger:

Microprocessor	Tattletale 8V2
Operating System	TxBasic Version 5.0
Total Data Storage	512M Bytes
12 Bit A/D Converter	8 Channels of 0-4.096 volts
Clock Stability	+/- 20PPM (+/-1 Min/Mon)

Resistivity Sensor:

Manufacturer	UW-Physics
Electronics Manufacturer	Ocean Eng. Services
Output	0 - 4 volts

Resistivity Temperature Sensor:

Sensor Manufacturer	Omega Engineering (Custom)
Probe Manufacturer	Ocean. Engineering Services
Model Number	CATi-116U-24
Type	K Thermocouple
Range	0-400 C

Reference Temperature Sensor:

Sensor Manufacturer	YSI
Model Number	44031
Characteristics	10K Ohms @ 25C
Usable Range	0 to 30 C

Hydrogen Sensor:

Probe Manufacturer	UW-Physics
Sensor	Entran EPXN-V03*-15P-/Z1
Sensor Output	0 – 69.88 mV FS equals 0-15 PSI
Electronic Gain	10
Usable Range	0-4.096 volts
Pressure Housing	Titanium (1.65”Dia x 3.5”)
Depth Rating	22732 PSI (50604 FT)
Power	4.096V @ 0.25 ma

eH Sensor:

Probe Manufacturer	Ko-ichi Nakamura
Sensor Output	+/-0.5 volts
Electronically shifted and amplified to	0 to 4 volts

BARS Specifications (Continued)

Logger Pressure Case:

Material	Titanium 6AL4V
Outside dimensions	5.0" Diameter, 19.5" Long
Weight in Air (With Electronics)	31.6 Lbs.
Weight in H2O (With Electronics)	15.6 Lbs.
Collapse Pressure	19656 PSI (43755 FT)

System Power Consumption: (All sensors turned on)

Logger Dropout Voltage	12 volts
System Maximum Voltage	30 volts
Peak current requirement	85 ma
Waiting to take next burst of data	52 ma
Taking A/D Data (5 seconds/cycle)	52 ma
Formatting Data (5 seconds/cycle)	77 ma
Sending Data (1 second/cycle)	85 ma
Menu Mode	50 ma

System Power Control:

Control Line 0	Res Electronics (+9 v)
Control Line 1	Instrumentation Amp (+9 v)
Control Line 2	Iso Amp (+9 v)
Control Line 4	Hydrogen Sensor (+Vref)
Control Line 5	Reference Temperature (+Vref)

System Communications:

Hardware Port	RS422
Baud Rate	9600 Baud

BARS Specifications (Continued)

Tattletale I/O Assignments:

Digital I/O:

TPU0	Analog Power Control (1 = On)
TPU1	Mux Strobe
TPU2	SDO Latch
TPU3	Not Used
TPU4	Freq. Input (Period/Count)
TPU5	S Clock
TPU6	Not Used
TPU7	Not Used
TPU8	SDO Data
TPU9	D-Out #1 (0 = On)
TPU10	D-Out #2 (0 = On)
TPU11	D-Out #4 (0 = On)
TPU12	Not Used
TPU13	RS232 Out#2 (UEND)
TPU14	RS232 In#2 (UGET)
TPU15	Not Used

Analog I/O (12 Bits):

A0	Resistivity/5
A1	Resistivity X1
A2	Resistivity X5
A3	Hydrogen/5
A4	Hydrogen X1
A5	Hydrogen X5
A6	Eh Sensor
A7	Mux Input
Mux0	Reference Temperature
Mux1	Resistivity Temperature
Mux2	Battery Voltage/10
Mux3	Not Used

Section 2

Operating Instructions



BARS Operating Instructions

A. Preparations for Deployment:

1. Since this device lives in a titanium pressure case, which is very durable and the microprocessor controller is programmed to be “Plug and Play”, one only needs to plug the sensors into the unit (clean and grease each connector) and attach the interconnecting cable that goes to the underwater cable system. Be sure to use the locking sleeves on each connector. There are no other necessary preparations.
2. If for some reason, you need to open the pressure case, remove the end cap with all the connectors first. To do this remove the 4 small screws that hold the multi-connector end cap to the pressure case. Then use fiberglass wedges to remove the endcap itself (**NEVER USE A SCREWDRIVER!**). The end cap is connected to the internal electronics through several connectors. Unplug them so the end cap is free. Next remove the opposite end cap that only has one connector using the same method. This end cap is also connected to the internal electronics with a connector. Once it is unplugged, this end cap is free. Then you can slide the electronics out of the case.
3. To talk to this instrument directly with the short interface cable for testing purposes, use a communications program like Onset’s TxTools software. Connect your computer’s RS232 serial port to the interface cable connector (DE9). Start TxTools on your computer. The first time you start TxTools, you will have to set the serial port configuration (9600 Baud). Apply 15 volt power to the interface cable’s banana connectors. After a few seconds, data will stream out of the system in 12 word bursts. The default time between bursts is 20 seconds, but it can be set to anything between 15 seconds and 60 minutes.
4. To access diagnostics and user options, enter the 2 key command “Control-S”. When the unit receives this command, it acknowledges it by sending back a line feed and a carriage return. When you see this, you have about ½ second to send another “Control-S” command, or it will be ignored. This double “Control-S” technique prevents false commands from stopping the data collection. If the unit is in data collection mode which typical lasts for about 6 seconds at the time that the system is setup to take data, it will ignore the “Control-S” command, so it is important to send this command when the unit is not taking data. When the “Control-S” command is properly sent and received, the microprocessor will display a Main Menu of options as follows:

Select one of the following functions:

- 0). Reprint Time and this Menu
- 1). Restart Data Collection
- 2). Change Data Collection Parameters
- 3). System Diagnostics
- 4). Set the system clock
- 5). Control Power to Sensors
- 6). Provide information on this system
- 7). Exit this program

BARS Operating Instructions

(continued)

5. When you enter the Main Menu mode, if you have not already set the system clock, you will see a notice to set it. This is done through option #4. After you have set the proper Date and Time, the current system time will be displayed along with the menu options.
6. Option #2 on this menu enables the user to change parameters, including the time between each burst (Cycle Time), whether the unit outputs only the data or goes into a verbose mode to assist debugging any problems remotely, and whether to enable or inhibit the output of the Metadata on power up and/or on restart of data collection. This submenu also has an option to force all the system parameters back to the default settings as shown in the system specifications. Lastly, this menu has an option to output all the system Metadata as a convenience.
7. Option #3 is a System Diagnostics to verify that everything is functioning correctly. See the typical diagnostic output data on the next page.
8. As already mentioned above, Option #4 enables the user to set the system clock.
9. Option #5 allowed the user to remotely turn power on/off to each selected sensors. This can be useful for diagnostics for example if there is a suspected ground loop due to a sensor leak or failure. It can also be used to turn off a damaged sensor that due to the ground loop currents or other problems, it is affecting all the other data.
10. Option #6 provides identification and contact information on this unit. The exact format is as follows:

System Name: BARS (Benthic and Resistivity Sensors)
System Owner: Marv Lilley, University of Washington
Owner Contact Phone #: 206-543-0859
System Serial #: 001
Software Version 1.86, Last Update March 28, 2012
Made by Ocean Engineering Service, July 2010 (206-543-9688)

This system is presently setup with the following parameters:

- 1 = Eprom Status (0 means not setup yet, 1 means ready to use)
- 20 = Cycle Time (Actual time in seconds or minutes)
- 0 = Minutes or seconds Cycle Time (0 = seconds mode, 1 = minutes mode)
- 55 = Power Control Word (Power Control Word = 1 + 2 + 4 + 16 + 32 = 55 if all on)
- 1 = Res Power Status (0 = Off, 1 = On)
- 1 = Thermocouple & Hydrogen Amp Power Status (0 = Off, 1 = On)
- 1 = eH Amp Power Status (0 = Off, 1 = On)
- 1 = Hydrogen Sensor Power Status (0 = Off, 1 = On)
- 1 = Reference Temperature Power Status (0 = Off, 1 = On)
- 0 = Metadata Print Status on Power Up (0 = No print on Power up, 1 = Print)

0 = Metadata Print Status on Restart Data Collection (0 = No print, 1 = Print)

11. The last option (#7) is necessary, since it is the only way to stop the program. If this option is selected, the following text comes up:

Are you really sure that you want to stop this program?
Enter 1 for Yes, 0 for No →

If the number 1 is entered, the program stops and the TxBasic Prompt will come up. If the number 0 is entered, you are returned to the Main Menu. Do not stop this program unless you really want to and understand the consequences.

12. To restart data collection, select option #1 on the Main Menu.

13. All the submenus that have lists of user's options can accept commands from 0 to 9. If you enter the number "9", while in any of these submenus, the program jumps back to the Main Menu.

14. This system is also setup to ignore random commands whether in the data collection mode or one of the Menu Modes. In addition, if the user enters a value outside the acceptable range of the requested parameter, the program will respond with a warning and the user will have the option of inputting a new value.

BARS Typical Diagnostic Output

This Test Routine Prints out the actual Analog Voltages
from all the Analog Inputs.
This should be helpful for system testing.

How Many Scans do you want? --> 20

-Res/5-	-ResX1-	-ResX5-	-*H2/5-	-*H2X1-	-*H2X5-	-*Eh**-	RefTemp	ResTemp	VBatt
0.131	0.645	3.167	0.044	0.241	1.448	2.000	1.875	1.227	9.123
0.129	0.646	3.159	0.122	0.621	3.046	2.001	1.876	1.278	9.121
0.130	0.647	3.168	0.126	0.619	3.047	2.000	1.875	1.275	9.122
0.132	0.650	3.168	0.129	0.621	3.046	2.001	1.871	1.280	9.122
0.131	0.646	3.165	0.126	0.621	3.052	2.000	1.876	1.280	9.121
0.130	0.647	3.184	0.132	0.623	3.050	2.001	1.876	1.280	9.123
0.131	0.644	3.170	0.127	0.625	3.051	1.999	1.871	1.276	9.122
0.130	0.646	3.188	0.129	0.622	3.046	2.002	1.875	1.279	9.123
0.131	0.647	3.170	0.129	0.620	3.049	2.000	1.871	1.279	9.122
0.133	0.647	3.164	0.126	0.623	3.046	2.000	1.875	1.279	9.121
0.130	0.647	3.161	0.126	0.622	3.045	2.000	1.876	1.280	9.122
0.132	0.647	3.163	0.128	0.620	3.046	2.000	1.877	1.279	9.122
0.129	0.647	3.166	0.130	0.622	3.048	2.001	1.874	1.282	9.122
0.130	0.646	3.166	0.129	0.620	3.044	2.000	1.876	1.279	9.123
0.129	0.651	3.166	0.127	0.621	3.046	1.999	1.872	1.280	9.122
0.132	0.644	3.188	0.127	0.632	3.050	2.001	1.873	1.279	9.123
0.131	0.646	3.176	0.126	0.624	3.045	2.001	1.874	1.280	9.122
0.132	0.645	3.159	0.129	0.623	3.049	2.002	1.870	1.280	9.121
0.131	0.643	3.173	0.128	0.628	3.047	2.000	1.874	1.279	9.122
0.128	0.646	3.168	0.126	0.621	3.052	1.998	1.874	1.280	9.123

Press Enter to return to Main Menu.

BARS Operating Instructions

(Continued)

B. User Operation Notes:

1. The recommended program to operate this logger is called BARS.TXB. It is written in Onset TxBasic.
2. Since this system is designed to be “Plug and Play”, when power is applied, data is automatically be sent out the RS422 port at 9600 Baud. Use a communications program like Onset’s TxTools to talk to the system.
3. To get to the Main Menu of user options, send the 2 key command “Control-S” to the unit from your communication program. The unit should respond with a line feed and a carriage return. You then have about ½ second to enter another “Control-S” command. The unit should bring up the Main Menu.
4. When the Main Menu is displayed, it will list all the user options. If the current Date and Time have not already been set, there will be a notice here to set it.
5. Every time you just press ENTER while in the Main Menu, the Current Date and Time along with the Menu will be reprinted.
6. Option 1 on the Main Menu starts the Data Collection routine. If you are in Data Only mode, only the 12 words of data will be outputted every burst. If you are in Verbose mode, Lots of information will be sent including data labels.
7. Option 2 allows the user to change data collection parameters such as the time between burst, whether to just see the data or go into a verbose mode to help find problems, and whether the Metadata is outputted on power up and at restart of data collection. It also has an option to force all the system parameters back to their default values per the specification page. Lastly it has an option to output all the system Metadata for the user’s convenience.
8. Option 3 on the Main Menu does diagnostics. Here you can look at the analog voltages from all the sensors. This can be very helpful to debug the system.
9. Option 4 allows the user to reset the Tattletale clock. When you press Enter to set the Seconds in the Time, the actual Date and Time are entered into the system. It is recommended that you use WWV or a GPS clock to set the time.
10. Option 5 allow the user to remotely control power to the sensors. This can be useful if a sensor has failed and is now leaking power into the water.
11. Option 6 provide system identification and owner contact information.
12. Option 7 enables the user to stop the program; there is no other to stop the program. But you want to be sure that you really want to do this. If you do stop the program, you will find yourself at

the TxB# prompt. To restart the program, enter a Control-X command followed by "Y" to get to the TOM monitor. Then enter the command "Go 2000" to restart BARS.TXB

BARS Operating Instructions (Continued)

C. Scientific Event Detection:

Events: There are several scales of events none of which are well defined in terms of their effect on the parameters being measured by our instrument. An Event could be a single earthquake, a swarm of earthquakes, a dike intrusion or a seafloor eruption. These would have progressively larger impacts on the sensors on our instrument.

Temperature Sensor – A sudden change in temperature (up or down) by 2 or 3 degrees likely means an event of some sort has occurred.

Resistivity Sensor- Changes in resistivity can occur as a result of changes in the mixing ratio between vapor, brine and seawater. These will likely be produced during earthquake events and the degree of change is difficult to predict. A change in resistivity of order 10% likely signifies a significant event. Diking or lava flow events could produce changes greater than 50%.

eH Sensor - This sensor responds to changes in the concentration of reduced chemical species in the fluid. Sharp decreases in voltage will accompany a phase separation event due to an increase in hydrogen sulfide.

Hydrogen Sensor – Hydrogen concentrations could increase due to both earthquakes and intrusive lava events but the intrusive events should produce a larger change (of order of tens of millimolar).

BARS Operating Instructions (Continued)

D. Troubleshooting Notes:

There are too many possible failures with any sophisticated instruments to list them all, so we will only provide a basic philosophy here. When things are not working properly be sure to try the following:

1. If you can still communicate with the instrument, run the diagnostics and look to see which sensors appear to have reasonable data. The most important value to check first is the voltage to the instrument which is the last column and labeled “Vbatt”. It should be about 9 volts. If it is not 9 volts within +/- 0.5 volts, the system input voltage regulator most likely has a serious problem and the instrument would need to be recovered and repaired. But before doing this serious step, try turning power off to each sensor one at a time to see if a sensor has failed and it bleeding power into the water.

2. Assuming the system voltage is correct, next check each of the data values to see if they are within normal range and reasonable. For each voltage value, the voltage must be between 0 and 4.095 volts. No other values are allowed. If there are values outside this range, that sensor is questionable and the unit will have to be recovered and serviced to get that sensor operational again. In any case, if a sensor has failed, it is recommended that power to that sensor be turned off to prevent deplating of the wires from the sensor back into the pressure case if the sensor has an electrical path to salt water. Note, two of the data channels (RefTemp and ResTemp) are outputted in degrees C, not voltage. The RefTemp should be a value between 1C and 5C if deployed in the ocean or 15 to 30C if in air. The ResTemp should be a value between 50 and 400C if deployed in a hydrothermal vent or 15 to 30C in air.

3. If one channel has voltage values that are locked at 0 or 4.095 volts, this most likely indicates that the sensor for that channel has failed. Depending on the need for that sensor, a decision would have to be made as to whether the instrument needs to be recovered to replace that sensor or can acceptable data still be collected. For example, the instrument can still take useful Resistivity data without Hydrogen and/or eH. However, in any case, if a sensor has failed, it is recommended that power to that sensor be turned off to prevent deplating of the wires from the sensor back into the pressure case if the sensor has an electrical path to salt water.

4. In evaluating Resistivity or Hydrogen, it must be noted that to achieve more resolution, the signal for each of these sensors is logged at 3 different gains. The first channel is the lowest gain and the following channels have an additional gain of 5 from the previous. If the first channel signal is very small, even the highest gain will still be under the 4.095 volt upper limit. If the signal is modest, the highest gain channel will be maxed out at 4.095. If the signal is large, all but the lowest gain channel will be maxed out. This does not mean that there is a problem with the sensor.

BARS Operating Instructions (Continued)

D. Troubleshooting Notes (continued):

5. Beyond the above diagnostics, any more serious problems will require that the instrument be recovered and checked out/repared in a lab. The following are suggestions to help find problems:

A. Check all the interconnection wiring between the boards, wiring to the batteries, and to the end cap of the pressure case. Because these wires can be flexed, they can work and break.

B. Check the voltage to the system and coming out of the main regulator which is heat sinked to a piece of aluminum at the bottom of the electronics frame. The input voltage to the system should be at least 12 volts and the output from the regulator should be around 9 volts. If the power to the Tattletale 8 drops below 7 volts, it will not operate any more.

C. Using a lab power supply if available and a digital volt meter, measure the power consumption of the unit. When the program is just sitting in the Main Menu, the current should be 50 ma and when it is logging the current should be around 33 to 85 ma.

D. If you stop the program by mistake, you will find yourself back at the TxB# prompt. To restart the program, enter the command Control-X followed by "Y". Then enter Go 2000 and the RES8B.txb program should restart.

E. Beyond the above simple tests, you will probably need to get Ocean Engineering Services to repair any serious problems.

BARS Operating Instructions (Continued)

E. Post Cruise Procedures:

This instrument requires only minimal attention following recovery.

1. Flush the entire unit with fresh water to remove any salt and dirt..
2. There is no need to open the pressure case unless you suspect damage.
3. Clean and regrease all underwater connectors.
4. Note any damage to the underwater units or sensors and have them repaired.

System Program

Model 800

extension CFSsize, CFAvail, CFSave, CFRead, CFExec, Burst2KSetup, BurstAD, BurstInfo

extension LPMode, StopWatchStart, StopWatchTime, ADOff, TPUoff, TPUon, HybAt3V

extension TserResetBaud, TserPutByte, TserOpen, TserInFlush, TserGetByte

extension TserClose, TserByteAvail

```
*****
'*  Tattletale 8 Canadian Benthic And Resistivity Sensors Program      *
'*                                                                    *
'*          Written by:  Rex Johnson                                     *
'*                   Ocean Engineering Services                       *
'*                   University of Washington                         *
'*                   Seattle, WA 98195                               *
'*                                                                    *
'*          Program Name:  BARS1PM2.TXB                               *
'*                                                                    *
'*          This Version was written specially for the Canadian Cable  *
'*          This Version is for BARS Serial Number 1 only            *
'*          It is designed to be Plug and Play                       *
'*          This version adds individual power control on sensors    *
'*          To get to the Main Menu, Use the Control-S Command      *
'*          When you see the Line Feed and Return,                  *
'*          Enter another Control-S                                  *
'*          Only check for Control-S command between Data Outputs    *
'*          Any received Control-C commands are completely ignored   *
'*          This Version adds Eprom storage of user parameters so    *
'*          if there is a power outage, the unit starts running     *
'*          again in the same mode; no user interaction required     *
'*          This version also adds an optional Metadata printout on  *
'*          startup and/or restart of logging                        *
'*          This version checks for bad data on setup of time        *
'*          This version corrects potential LowBatt Error           *
*****
```

'Hardware:

' I/O lines:

```
'   D0 = Power Control (1 = On)
'   D1 = Mux Strobe
'   D2 = SDO Latch on Power Control Board
'   D3 = Port 3 Serial In
'   D4 = Period, Count Input
'   D5 = SDI, SDO Clock for Power Control Board
'   D6 = Max 232 Power (Low = On)
'   D7 = Port 3 Serial Out
'   D8 = SDO Data for Power Control Board
'   D9 = Digital Out #1 (ABS Control Line) (Low = On)
'   D10 = Digital Out #2 (ADCP Control Line) (Low = On)
'   D11 = Digital Out #4 or Software UART #2 (Low = On)
'   D12 = Port 4 Serial In
'   D13 = USEND (#2 RS232 Output)
'   D14 = UGET (#2 RS232 Input)
'   D15 = Port 4 Serial Out
```

' Analog Inputs (12 Bit A/D)

```
'   A0 = Resistivity /5
'   A1 = Resistivity X1
'   A2 = Resistivity X5
'   A3 = Hydrogen /5
'   A4 = Hydrogen X1
```



```

'   A5 = Hydrogen X5
'   A6 = eH Sensor
'   A7 = Mux Input
' Mux0 = Reference Temp
' Mux1 = Thermocouple Temp
' Mux2 = Battery/10
' Mux3 = Not Used
'
' Power Control using [ SDO PwrWord, 16 ] Command
' To control Power to each device, the control word "PwrWord"
' should be the summation of each number corresponding to each device listed
' Chan 0 ..... Res = 1
' Chan 1 .....Instrumentation Amp = 2
' Chan 2 ..... eH Isolation Amp = 4
' Chan 3 ..... Spare = 8
' Chan 4 ..... Hydrogen = 16
' Chan 5 ..... Reference Temperature = 32
' Chan 6 ..... Spare = 64
' Chan 7 ..... Spare = 128
' Chan 8 ..... Spare = 256
' Chan 9 ..... Spare = 512
' Chan 10 ..... Spare = 1024
' Chan 11 ..... Spare = 2048
' Chan 12 ..... Spare = 4096
' Chan 13 ..... Spare = 8192
' Chan 14 ..... Spare = 16384
' Chan 15 ..... Spare = 32768
'
' Eprom Storage location assignments (Only Locations 0-31 available)
'   0 .... Status, 0 means not setup yet, 1 means ready to use
'   1 .... CycleTime, Default = 20
'   2 .... MinOrSec, Default = 0 (0 = seconds, 1 = minutes)
'   3 .... PwrWord, Default = 55 (Power Control Word for SDO command =
1+2+4+16+32=55)
'   4 .... ResPwrStatus, Default = 1 (0 = off, 1 = on)
'   5 .... InstrAmpPwrStatus, Default = 1
'   6 .... IsoPwrStatus, Default = 1
'   7 .... H2PwrStatus, Default = 1
'   8 .... RefTempPwrStatus, Default = 1
'   9 .... Print all Metadata on powerup, Default = 0 (0 = no print, 1 =
print)
'  10 .... Print all Metadata on restart of data collection, Default = 0 (0
= no print, 1 = print)
'
' Serial Ports Assignments
' Port 3 (Not Used)
'   Input (RX3) = D3
'   Output (TX3) = D7
' Port 4 (Not Used)
'   Input (RX4) = D12
'   Output (TX4) = D15
'
' Memory allocation
' 0 to 600000 = Datafile
' 600001 to 900000 = Diagnostics
'
' Set up Month Array, Data Character Array
DIM M(13)
Dim D(14)

```

```

' Be sure all power is turned off
GOSUB TurnOffEverything
' What to do if an error
ONERR ErrorRoutine
' What do if receive a Control-C
' First setup command extension
extension CtrlCHandle
' Execute Command to Completely ignore all Control-C commands
CtrlCHandle(0)

' Set Default Parameters
LF = 10
CR = 13
ClockStatus = 0 // Has the System Clock been set (0 = No, 1 = Yes)
ADRate = 2 // Samples per Second
BOFMarker = -123 // BOF File Marker
Append = 1 // Always append the data file
LowBattMode = 0 // 0 = normal mode, 1 = Low Batt
Verbose = 0 // 0 = print data only, 1 = print all status information
Pointer = 100 // Set an arbitrary pointer location so we can find
Control-S input
WriteDataStatus = 0 // 0 = Do not write data to memory, 1 = write data to
memory
' Set up Hybernate mode
' Mode 0 causes TT8 to stay at 5 volt power
' Mode 1 causes TT8 to drop to 3 volt power
Mode = 1
HybAt3V(Mode)
' Set up the number of days in the Month Array
M(1) = 31
M(2) = 28
M(3) = 31
M(4) = 30
M(5) = 31
M(6) = 30
M(7) = 31
M(8) = 31
M(9) = 30
M(10) = 31
M(11) = 30
M(12) = 31

' Check to see if Eprom Memory has been setup with parameters
' Any value other than 1 means current parameters have not been stored
' If parameters have not stored, then store default values and use default
values
' If parameters have been stored, use the stored values
EpromStatus = VGET(0)
IFF EpromStatus <> 1
    VSTORE 0, 1 // Set EpromStatus = 1 (0 = Memory not setup, 1 =
setup)
    VSTORE 1, 20 // Set CycleTime = 20 Minutes or Seconds
depending on MinOrSec
    VSTORE 2, 0 // Set MinOrSec = 1 for Min, or = 0 for Sec
    VSTORE 3, 55 // Set PwrWord = 55, Power Control Word for SDO
command = 1+2+4+16+32=55
    VSTORE 4, 1 // Set ResPwrStatus = 1 for Power On, 0 = Power Off
    VSTORE 5, 1
    VSTORE 6, 1

```

```

        VSTORE 7, 1
        VSTORE 8, 1
        VSTORE 9, 0          // Set MetadataStatusPowerUp = 0 for Do not print on
Powerup, 1 = print
        VSTORE 10, 0       // Set MetadataStatusRestartData = 0 for Do not
print on restart of data collection, 1 = print
ENDIF
EepromStatus = VGET(0)
IFF EepromStatus = 1
    CycleTime = VGET(1)
    MinOrSec = VGET(2)
    PwrWord = VGET(3)
    ResPwrStatus = VGET(4)
    InstrAmpPwrStatus = VGET(5)
    IsoPwrStatus = VGET(6)
    H2PwrStatus = VGET(7)
    RefTempPwrStatus = VGET(8)
    MetadataStatusPowerUp = VGET(9)
    MetadataStatusRestartData = VGET(10)
ENDIF

'Print a blank line to show unit is alive
PRINT

'Check to see if print Metadata
IFF VGET(9) = 1
    GOSUB PrtSysInfo
    PRINT
    GOSUB PrintParameters
    PRINT
ENDIF

'For Plug and Play, jump to Data Collection
GOTO TakeData

SetTime:
' Newest Routine to block bad data entries
GOSUB ClearScreen
PRINT "          This routine is to set or adjust the System Clock."
PRINT
RTIME
PRINT "          The Current System Date = ";
PRINT #02,?(4),"/",?(3),"/",?(5)
PRINT "          The Current System Time = ";
PRINT #02,?(2),":",?(1),":",?(0)
INPUT "          Do you want to Change the Current Time? (0 = No, 1 = Yes) --> " A
IF A = 0 GOTO MainMenu
IF A <> 1 GOTO SetTime

InputMonth:
INPUT "          Enter the Month (1-12): " Amonth
IFF Amonth > 12 | Amonth < 1
    GOSUB InputErrors
    PRINT
    GOTO InputMonth
ENDIF
CheckFeb:
IFF Amonth = 2
    PRINT

```

```

        PRINT " Is this a Leap Year? "
        INPUT " Enter 1 for Yes, 0 for No --> " AA
        IFF AA > 1 | AA < 0
            GOSUB InputErrors
            PRINT
            GOTO CheckFeb
        ENDIF
ENDIF
?(4) = Amonth

InputDay:
IF Amonth = 1 GOTO Days31
IF Amonth = 3 GOTO Days31
IF Amonth = 5 GOTO Days31
IF Amonth = 7 GOTO Days31
IF Amonth = 8 GOTO Days31
IF Amonth = 10 GOTO Days31
IF Amonth = 12 GOTO Days31
IF Amonth = 4 GOTO Days30
IF Amonth = 4 GOTO Days30
IF Amonth = 4 GOTO Days30
IF Amonth = 4 GOTO Days30
IF Amonth = 2 GOTO FebDays
' If you get here, you entered a bad number
GOSUB InputErrors
PRINT
GOTO InputMonth

Days31:
INPUT "      Enter the Day (1-31): " A
IFF A > 31 | A < 1
    GOSUB InputErrors
    PRINT
    GOTO InputDay
ENDIF
?(3) = A
GOTO InputYear

Days30:
INPUT "      Enter the Day (1-30): " A
IFF A > 30 | A < 1
    GOSUB InputErrors
    PRINT
    GOTO InputDay
ENDIF
?(3) = A
GOTO InputYear

FebDays:
IF AA = 1 GOTO Days29
IF AA = 0 GOTO Days28
' If you get here, you entered a bad number
GOSUB InputErrors
PRINT
GOTO InputMonth

Days28:
INPUT "      Enter the Day (1-28): " A
IFF A > 28 | A < 1

```

```

        GOSUB InputErrors
        PRINT
        GOTO InputDay
ENDIF
?(3) = A
GOTO InputYear

Days29:
INPUT "      Enter the Day (1-29): " A
IFF A > 29 | A < 1
        GOSUB InputErrors
        PRINT
        GOTO InputDay
ENDIF
?(3) = A

InputYear:
INPUT "      Enter the Year (Two Digits): " A
IFF A > 99 | A < 12
        GOSUB InputErrors
        PRINT
        GOTO InputYear
ENDIF
?(5) = A

InputHour:
INPUT "      Enter the Hour (0-23): " A
IFF A > 23 | A < 0
        GOSUB InputErrors
        PRINT
        GOTO InputHour
ENDIF
?(2) = A

InputMinute:
INPUT "      Enter the Minute (0-59): " A
IFF A > 59 | A < 0
        GOSUB InputErrors
        PRINT
        GOTO InputMinute
ENDIF
?(1) = A

InputSecond:
INPUT "      Enter the Second (0-59): " A
IFF A > 59 | A < 0
        GOSUB InputErrors
        PRINT
        GOTO InputSecond
ENDIF
?(0) = A

' Change the Clock Status Word
ClockStatus = 1
STIME
RTIME
GOTO SetTime

MainMenu:

```

```

GOSUB TurnOffEverything
GOSUB ClearScreen
PRINT: PRINT
PRINT " *****"
print " *
PRINT " *          Welcome to the BARS Program Main Menu          *
PRINT " *          (Benthic And Resistivity Sensors)                *
PRINT " *          (Serial Number 001)                               *
Print " *
print " *****"
print
PRINT "          Version 1.86 - Last Revision: Mar. 28, 2012"
PRINT
PRINT "          Written by:"
PRINT
PRINT "          Rex Johnson"
PRINT "          Ocean Engineering Services"
PRINT "          School of Oceanography"
PRINT "          University of Washington"
PRINT "          Seattle, WA 98195"
PRINT: PRINT
IFF ClockStatus = 0
    PRINT "          The System Clock has not been set."
    PRINT "          Use option 4 to Set the Clock."
    PRINT
    GOTO PrintOptions
ENDIF
RTIME
PRINT "          The Current Tattletale Date = ";
PRINT #02,?(4),"/",?(3),"/",?(5)
PRINT "          The Current Tattletale Time = ";
PRINT #02,?(2),":",?(1),":",?(0)
PRINT
PrintOptions:
PRINT "          Select one of the following functions:"
PRINT
PRINT "          0). Reprint Time & this Menu."
PRINT "          1). Restart Data Collection."
PRINT "          2). Change Data Collection Parameters."
PRINT "          3). System Diagnostics."
PRINT "          4). Set the System Clock."
PRINT "          5). Control Power to Sensors."
PRINT "          6). Provide Information on this System."
PRINT "          7). Exit this Program."
PRINT
INPUT "          Enter 0, 1, 2, 3, 4, 5, 6 or 7 here --> " A
IF A = 0 GOTO MainMenu
IF A = 1 GOTO SetupToTakeData
IF A = 2 GOTO SetParameters
IF A = 3 GOTO SystemDiag
IF A = 4 GOTO SetTime
IF A = 5 GOTO SetPwrCntrl
IF A = 6 GOTO SysInfo
IF A = 7 GOTO AreYouSure
GOTO MainMenu

```

SystemDiag:

' This routine can test each device for operation and signal
' Test Routine uses the Chan() command, which is based on putting the

```

' 12 bit A/D conversion into the upper part of the 16 bit word.
PRINT: PRINT
' Turn on TPU Processor
TPUon()
' Turn on analog power
PSET 0
' Turn on Sensor Power
SDO PwrWord, 16
GOSUB ClearScreen
PRINT "          This Test Routine Prints out the actual Analog Voltages"
PRINT "                    from all the Analog Inputs."
PRINT "                    This should be helpful for system testing."
PRINT
PRINT
INPUT "          How Many Scans do you want? --> " Answer
Print
Hcount = 0
FOR I = 1 TO Answer
'Reset Mux
Pset 1
Sleep 0: Sleep 10
Pclr 1
IFF Hcount = 0
    Print
    Print "-Res/5- -ResX1- -ResX5- -*H2/5- -*H2X1- -*H2X5- -*Eh**- RefTemp
    ResTemp -VBatt-"
ENDIF
' Get first 6 channels
FOR J = 0 to 6
Volts! = chan(J)*4.096/65520
print #5.3F, Volts;
print "    ";
Next J
' Now get the Reference Temperature on the Mux
Volts = chan(7)*4.096/65520
print #5.3F, Volts;
print "    ";
' Move the Mux to the Next Channel
Pset 1: Pclr 1
' Wait for it to Stabilize
Sleep 0 : Sleep 10
' Now get the Thermocouple Temperature on the Mux
Volts = chan(7)*4.096/65520
print #5.3F, Volts;
print "    ";
' Move the Mux to the Next Channel
Pset 1: Pclr 1
' Wait for it to Stabilize
Sleep 0 : Sleep 10
' Now get the Battery Voltage
Volts = chan(7)*4.096/65520
' Multiply by 10
Volts = 10*Volts
print #5.3F, Volts;
print "    ";
print
Hcount = Hcount + 1
IF Hcount = 20 Hcount = 0
Next I

```

```

INPUT "Press Enter to return to Main Menu." Answer
' Turn power off to sensors
SDO 0, 16
' Turn Power Off Too
Pclr 0
GOTO MainMenu

SetParameters:
GOSUB ClearScreen
PRINT "
                                System Parameter Menu"
PRINT
PRINT
"*****"
"
PRINT
PRINT "
                                The present value for the Cycle Time is"
IFF MinOrSec = 0
PRINT "
                                ",CycleTime," Seconds."
ENDIF
IFF MinOrSec = 1
PRINT "
                                ",CycleTime," Minutes."
ENDIF
PRINT
PRINT "
                                The present setting for Verbose versus Data only is"
IFF Verbose = 0
PRINT "
                                Data Only."
ENDIF
IFF Verbose = 1
PRINT "
                                Verbose Printing of Status Information with the
Data."
ENDIF
PRINT
IFF VGET(9) = 0
PRINT "
                                Printing of the Metadata Printing on Power up is
inhibited."
ENDIF
IFF VGET(9) = 1
PRINT "
                                Printing of the Metadata Printing on Power up is
enabled."
ENDIF
PRINT
IFF VGET(10) = 0
PRINT "
                                Printing of the Metadata Printing on Restart of Data
is inhibited."
ENDIF
IFF VGET(10) = 1
PRINT "
                                Printing of the Metadata Printing on Restart of Data
is enabled."
ENDIF
PRINT
PRINT
"*****"
"
PRINT: PRINT
PRINT "
                                Select one of the following functions:"
PRINT
PRINT "
                                0). Reprint this Menu."
PRINT "
                                1). Change the Cycle Time."
PRINT "
                                2). Change the Verbose Setting."

```



```

PRINT "          3). Change Print Status of Metadata on Powerup."
PRINT "          4). Change Print Status of Metadata on Restart
of Data."
PRINT "          5). Reset all Parameters back to Default
Settings."
PRINT "          6). Print out all Parameters."
PRINT "          7 to 9). Return to the Main Menu."
PRINT
INPUT "          Enter 0 through 9 here --> " A
IF A = 0 GOTO SetParameters
IF A = 1 GOSUB SetCycleTime
IF A = 2 GOSUB SetVerbose
IF A = 3 GOSUB SetMetadataStatus1
IF A = 4 GOSUB SetMetadataStatus2
IF A = 5 GOSUB ResetParameters
IFF A = 6
    GOSUB ClearScreen
    GOSUB PrintParameters
    PRINT
    INPUT " Press ENTER to continue. " A
ENDIF
IF A > 6 GOTO MainMenu
GOTO SetParameters

SetCycleTime:
GOSUB ClearScreen
Print "          Do you want to specify a Cycle Time in"
Print "          in Seconds or Minutes?"
Input "          Enter 0 for Seconds, 1 for Minutes --> " A
IF A < 0 | A > 1 GOSUB InputErrors: GOTO SetCycleTime
MinOrSec = A
Print
Print
IFF MinOrSec = 0
INPUT "          Enter a new value between 15 and 59 here --> " A
IF A < 15 | A > 59 GOSUB InputErrors: GOTO SetCycleTime
Endif
IFF MinOrSec = 1
INPUT "          Enter a new value between 1 and 60 here --> " A
IF A < 1 | A > 60 GOSUB InputErrors: GOTO SetCycleTime
Endif
CycleTime = A
' Save parameters to Eprom
VSTORE 1, CycleTime
VSTORE 2, MinOrSec
' Reset Variable A so no go back to Main Menu
A = 0
Return

SetVerbose:
GOSUB ClearScreen
Print " Do you want Verbose Status Information during Logging"
Print "          or just the Data?"
Input "          Enter 1 for Verbose, 0 for just Data. --> " Verbose
If Verbose < 0 GOTO SetVerbose
If Verbose > 1 GOTO SetVerbose
Return

SetMetadataStatus1:

```

```

GOSUB ClearScreen
Print " Do you want the Metadata Information printed out at Power up?"
PRINT
Input "      Enter 1 for Yes, 0 for No. --> " A
If A = 0 VSTORE 9, 0
If A = 1 VSTORE 9, 1
Return

SetMetadataStatus2:
GOSUB ClearScreen
Print " Do you want the Metadata Information printed out at restart of data
collection?"
PRINT
Input "      Enter 1 for Yes, 0 for No. --> " A
If A = 0 VSTORE 10, 0
If A = 1 VSTORE 10, 1
Return

SetPwrCntrl:
' Allow user to turn On/Off power to each sensor
GOSUB ClearScreen
IFF PwrWord < 0 | PwrWord > 55
    PRINT "***** WARNING !!! *****"
    PRINT
    PRINT "      The Power Control Word = ", PwrWord
    PRINT "      This is not possible!"
    PRINT "      The Power Control Word must be a positive number < 56"
    PRINT
    PRINT "      This program is resetting this Word so that all sensors are
on."
    PwrWord = 55
    INPUT "      Press ENTER to Continue. " A
ENDIF
PRINT "
Sensor Power Control Menu"
PRINT
PRINT
PRINT "*****"
"
PRINT
PRINT "      Here is the current status of power to each sensor"
PRINT
PRINT "      Res Sensor Power is ..... ";
IF ResPwrStatus = 1 PRINT "On"
IF ResPwrStatus = 0 PRINT "Off"
PRINT "      Instrumentation Amp Power is .... ";
IF InstrAmpPwrStatus = 1 PRINT "On"
IF InstrAmpPwrStatus = 0 PRINT "Off"
PRINT "      eH Isolation Amp Power is ..... ";
IF IsoPwrStatus = 1 PRINT "On"
IF IsoPwrStatus = 0 PRINT "Off"
PRINT "      Hydrogen Power ..... ";
IF H2PwrStatus = 1 PRINT "On"
IF H2PwrStatus = 0 PRINT "Off"
PRINT "      Reference Temperature Power ..... ";
IF RefTempPwrStatus = 1 PRINT "On"
IF RefTempPwrStatus = 0 PRINT "Off"

PRINT

```

```

PRINT
"*****"
"
PRINT: PRINT
PRINT "          Select one of the following functions:"
PRINT
PRINT "          0).  Reprint this Menu."
PRINT "          1).  Toggle Power to Res Sensor."
PRINT "          2).  Toggle Power to the Instrumentation Amp."
PRINT "          3).  Toggle Power to the eH Isolation Amp."
PRINT "          4).  Toggle Power to the Hydrogen Sensor."
PRINT "          5).  Toggle Power to the Reference Temperature
Sensor."
PRINT "          6 to 9).  Return to the Main Menu."
PRINT
INPUT "          Enter 0 through 9 here --> " A
IF A = 0 GOTO SetPwrCntrl
IF A = 1 GOSUB ToggleResPwr
IF A = 2 GOSUB ToggleInstrAmpPwr
IF A = 3 GOSUB ToggleIsoAmpPwr
IF A = 4 GOSUB ToggleH2Pwr
IF A = 5 GOSUB ToggleRefTempPwr
IF A > 5 GOTO MainMenu
GOTO SetPwrCntrl

ToggleResPwr:
'Check for errors first
IFF ResPwrStatus < 0 | ResPwrStatus > 1
    GOSUB ClearScreen
    PRINT " There has been a Error in the Power Control Word"
    PRINT " Reset all Parameters back to Default Values using Main Menu
Option 2"
    INPUT "Press ENTER to Continue. " A
    GOTO SetPwrCntrl
ENDIF
' Toggle Res Power
IFF ResPwrStatus = 1
    ResPwrStatus = 0
    PwrWord = PwrWord - 1
    VSTORE 3, PwrWord
    VSTORE 4, ResPwrStatus
    RETURN
ENDIF
IFF ResPwrStatus = 0
    ResPwrStatus = 1
    PwrWord = PwrWord + 1
ENDIF
VSTORE 3, PwrWord
VSTORE 4, ResPwrStatus
RETURN

ToggleInstrAmpPwr:
'Check for errors first
IFF InstrAmpPwrStatus < 0 | InstrAmpPwrStatus > 1
    GOSUB ClearScreen
    PRINT " There has been a Error in the Power Control Word"
    PRINT " Reset all Parameters back to Default Values using Main Menu
Option 2"
    INPUT "Press ENTER to Continue. " A

```

```

        GOTO SetPwrCntrl
ENDIF
' Toggle Instrumentation Amp Power
IFF InstrAmpPwrStatus = 1
    InstrAmpPwrStatus = 0
    PwrWord = PwrWord - 2
    VSTORE 3, PwrWord
    VSTORE 5, InstrAmpPwrStatus
    RETURN
ENDIF
IFF InstrAmpPwrStatus = 0
    InstrAmpPwrStatus = 1
    PwrWord = PwrWord + 2
ENDIF
VSTORE 3, PwrWord
VSTORE 5, InstrAmpPwrStatus
RETURN

ToggleIsoAmpPwr:
IFF IsoPwrStatus < 0 | IsoPwrStatus > 1
    GOSUB ClearScreen
    PRINT " There has been a Error in the Power Control Word"
    PRINT " Reset all Parameters back to Default Values using Main Menu
Option 2"
    INPUT "Press ENTER to Continue. " A
    GOTO SetPwrCntrl
ENDIF
' Toggle eH Isolation Amp Power
IFF IsoPwrStatus = 1
    IsoPwrStatus = 0
    PwrWord = PwrWord - 4
    VSTORE 3, PwrWord
    VSTORE 6, IsoPwrStatus
    RETURN
ENDIF
IFF IsoPwrStatus = 0
    IsoPwrStatus = 1
    PwrWord = PwrWord + 4
ENDIF
VSTORE 3, PwrWord
VSTORE 6, IsoPwrStatus
RETURN

ToggleH2Pwr:
IFF H2PwrStatus < 0 | H2PwrStatus > 1
    GOSUB ClearScreen
    PRINT " There has been a Error in the Power Control Word"
    PRINT " Reset all Parameters back to Default Values using Main Menu
Option 2"
    INPUT "Press ENTER to Continue. " A
    GOTO SetPwrCntrl
ENDIF
' Toggle Hydrogen Sensor Power
IFF H2PwrStatus = 1
    H2PwrStatus = 0
    PwrWord = PwrWord - 16
    VSTORE 3, PwrWord
    VSTORE 7, H2PwrStatus
    RETURN

```

```

ENDIF
IFF H2PwrStatus = 0
    H2PwrStatus = 1
    PwrWord = PwrWord + 16
ENDIF
VSTORE 3, PwrWord
VSTORE 7, H2PwrStatus
RETURN

ToggleRefTempPwr:
IFF RefTempPwrStatus < 0 | RefTempPwrStatus > 1
    GOSUB ClearScreen
    PRINT " There has been a Error in the Power Control Word"
    PRINT " Reset all Parameters back to Default Values using Main Menu
Option 2"
    INPUT "Press ENTER to Continue. " A
    GOTO SetPwrCntrl
ENDIF
' Toggle Reference Temperature Sensor Power
IFF RefTempPwrStatus = 1
    RefTempPwrStatus = 0
    PwrWord = PwrWord - 32
    VSTORE 3, PwrWord
    VSTORE 8, RefTempPwrStatus
    RETURN
ENDIF
IFF RefTempPwrStatus = 0
    RefTempPwrStatus = 1
    PwrWord = PwrWord + 32
ENDIF
VSTORE 3, PwrWord
VSTORE 8, RefTempPwrStatus
RETURN

ResetParameters:
VSTORE 0, 1          // Set EpromStatus = 1
VSTORE 1, 20         // Set CycleTime = 20 Minutes or Seconds depending on
MinOrSec
VSTORE 2, 0          // Set MinOrSec = 1 for Min, or = 0 for Sec
VSTORE 3, 55         // Set PwrWord = 55, Power Control Word for SDO
command = 1+2+4+16+32=55
VSTORE 4, 1          // Set ResPwrStatus = 1 for Power On
VSTORE 5, 1
VSTORE 6, 1
VSTORE 7, 1
VSTORE 8, 1
VSTORE 9, 0          // Set MetadataStatusPowerUp = 0 for no print on power up
VSTORE 10, 0         // Set MetadataStatusRestartData = 0 for no print on
restart
EpromStatus = VGET(0)
CycleTime = VGET(1)
MinOrSec = VGET(2)
PwrWord = VGET(3)
ResPwrStatus = VGET(4)
InstrAmpPwrStatus = VGET(5)
IsoPwrStatus = VGET(6)
H2PwrStatus = VGET(7)
RefTempPwrStatus = VGET(8)
MetadataStatusPowerUp = VGET(9)

```

```
MetadataStatusRestartData = VGET(10)
RETURN
```

```
PrintParameters:
```

```
' Eprom Storage location assignments (Only Locations 0-31 available)
' 0 .... Status, 0 means not setup yet, 1 means ready to use
' 1 .... CycleTime, Default = 20
' 2 .... MinOrSec, Default = 0
' 3 .... PwrWord, Default = 55
' 4 .... ResPwrStatus, Default = 1
' 5 .... InstrAmpPwrStatus, Default = 1
' 6 .... IsoPwrStatus, Default = 1
' 7 .... H2PwrStatus, Default = 1
' 8 .... RefTempPwrStatus, Default = 1
' 9 .... MetadataStatusPowerUp, Default = 0
' 10 .... MetadataStatusRestartData, Default = 0
PRINT " This System is presently setup with the following Parameters:"
PRINT VGET(0), " = Eprom Status (0 means not setup yet, 1 means ready to
use)"
PRINT VGET(1), " = Cycle Time (Actual Time in Seconds or Minutes)"
PRINT VGET(2), " = Minutes or Seconds Cycle Time (0 = Seconds mode, 1 =
Minutes mode)"
PRINT VGET(3), " = Power Control Word (Power Control Word = 1+2+4+16+32 = 55
if all On)"
PRINT VGET(4), " = Res Power Status (0 = Off, 1 = On)"
PRINT VGET(5), " = Thermocouple & Hydrogen Amp Power Status (0 = Off, 1 =
On)"
PRINT VGET(6), " = eh Amp Power Status (0 = Off, 1 = On)"
PRINT VGET(7), " = Hydrogen Sensor Power Status (0 = Off, 1 = On)"
PRINT VGET(8), " = Reference Temperature Power Status (0 = Off, 1 = On)"
PRINT VGET(9), " = Metadata Print Status on Power up (0 = No Print on
Powerup, 1 = Print)"
PRINT VGET(10), " = Metadata Print Status on Restart Data Collection (0 = No
Print on Restart Data, 1 = Print)"
RETURN
```

```
SysInfo:
```

```
' Print out System Information to identify this system
GOSUB ClearScreen
GOSUB PrtSysInfo
PRINT
GOSUB PrintParameters
PRINT
INPUT " Press Enter to return to the Main Menu. --> " A
GOTO MainMenu
```

```
PrtSysInfo:
```

```
PRINT
PRINT " System Name: BARS (Benthic And Resistivity Sensors)"
PRINT " System Owner: Marv Lilley, University of Washington"
PRINT " Owner Contact Phone #: 206-543-0859"
PRINT " System Serial #: 001"
PRINT " Software Version 1.86, Last Update March 28, 2012"
PRINT " Made by Ocean Engineering Services, July 2010 (206-543-9688)"
RETURN
```

```
AreYouSure:
```

```
' To verify that user really wants to stop this program
GOSUB ClearScreen
```

```

PRINT " You have requested to stop this program."
PRINT
PRINT " Once the Program has been stopped, to restart the program,"
PRINT " just cycle the system power. This system is programmed as"
PRINT " Plug and Play, so it will power up running."
PRINT
PRINT " Are you really sure that you want to stop this program?"
INPUT " Enter 1 for Yes, 0 for No --> " A
IFF A = 1
' Stop the program
' Turn Off Everything
    GOSUB TurnOffEverything
    STOP
ENDIF
GOTO MainMenu

SetupToTakeData:
'Check to see if print Metadata
IFF VGET(10) = 1
    GOSUB PrtSysInfo
    PRINT
    GOSUB PrintParameters
    PRINT
ENDIF

TakeData:
HeaderStatus = 0
' Setup the Starting Time & Date Array
' Always set start time to actual time
RTIME
BrtTimeSec = ?(0)
BrtTimeMin = ?(1)
BrtTimeHr = ?(2)
BrtTimeDay = ?(3)
BrtTimeMon = ?(4)
BrtTimeYr = ?(5)
' If in Minute mode, Seconds always = 0
If MinOrSec = 1 BrtTimeSec = 0
If MinOrSec = 0 BrtTimeSec = ?(0)
' Print "Calculated BrtTimeSec = ", BrtTimeSec
Goto SetupToLog

' No need this section
' Check for overflow
IFF BrtTimeSec > 59
    BrtTimeSec = 0
    BrtTimeMin = BrtTimeMin + 1
Endif
Iff BrtTimeMin > 59
    BrtTimeMin = 0
    BrtTimeHr = BrtTimeHr + 1
ENDIF
Iff BrtTimeHr > 23
    BrtTimeHr = 0
    BrtTimeDay = BrtTimeDay + 1
ENDIF
IF BrtTimeDay > 28 & BrtTimeMon = 2 GOTO AnotherDay
IF BrtTimeDay > 30 & BrtTimeMon = 4 GOTO AnotherDay
IF BrtTimeDay > 30 & BrtTimeMon = 6 GOTO AnotherDay

```

```

IF BrtTimeDay > 30 & BrtTimeMon = 9 GOTO AnotherDay
IF BrtTimeDay > 30 & BrtTimeMon = 11 GOTO AnotherDay
IF BrtTimeDay < 32 GOTO SetupToLog
AnotherDay:
BrtTimeDay = 1
BrtTimeMon = BrtTimeMon + 1
IF BrtTimeMon < 12 GOTO SetupToLog
BrtTimeMon = 1
BrtTimeYr = BrtTimeYr + 1
GOTO SetupToLog

CalNextBurstTime:
RTIME
' Calculate the next Burst Date & Time
' Add CycleTime to get to next burst
' CycleTime can be Seconds or Minutes depending on Value of MinOrSec
IFF MinOrSec = 0
    BrtTimeSec = BrtTimeSec + CycleTime
BurstTimeLoop0:
' Check to see if overflow
    IF BrtTimeSec < 60 GOTO LogLoop
    BrtTimeSec = BrtTimeSec - 60
    BrtTimeMin = BrtTimeMin + 1
    if BrtTimeSec > 59 goto BurstTimeLoop0
Endif
IFF MinOrSec = 1
    BrtTimeMin = BrtTimeMin + CycleTime
Endif
BurstTimeLoop1:
' Check to see if overflow
IF BrtTimeMin < 60 GOTO LogLoop
BrtTimeMin = BrtTimeMin - 60
BrtTimeHr = BrtTimeHr + 1
if BrtTimeMin > 59 goto BurstTimeLoop1
CheckHours:
IF BrtTimeHr < 24 GOTO LogLoop
BrtTimeHr = BrtTimeHr - 24
BrtTimeDay = BrtTimeDay + 1
IF BrtTimeDay > 28 & BrtTimeMon = 2 GOTO NextDay
IF BrtTimeDay > 30 & BrtTimeMon = 4 GOTO NextDay
IF BrtTimeDay > 30 & BrtTimeMon = 6 GOTO NextDay
IF BrtTimeDay > 30 & BrtTimeMon = 9 GOTO NextDay
IF BrtTimeDay > 30 & BrtTimeMon = 11 GOTO NextDay
IF BrtTimeDay < 32 GOTO LogLoop
NextDay:
BrtTimeDay = 1
BrtTimeMon = BrtTimeMon + 1
IF BrtTimeMon < 12 GOTO LogLoop
BrtTimeMon = 1
BrtTimeYr = BrtTimeYr + 1

LogLoop:
RTIME
IFF Verbose = 1
PRINT
PRINT "    The Present Date & Time is -> Date = ",#02,?(4),"/",?(3),"/",?(5);
PRINT "    Time = ",#02,?(2),":",?(1),":",?(0)
' Print next cycle date / time

```



```

PRINT "      The Next Cycle will be at --> Date =
",#02,BrtTimeMon,"/",BrtTimeDay,"/",BrtTimeYr;
PRINT "      Time = ",#02, BrtTimeHr,":",BrtTimeMin,":",BrtTimeSec
Endif
AnotherCycle:
' Is it time to do another cycle?
RTIME
' Check for User command to Stop
GOSUB UserCommand
IFF KeyCommand = 19
' Send out Line Feed and Return to show Control-S has been received
PRINT
' Check for another Control-S Command
GOSUB UserCommand
IFF KeyCommand = 19
Goto MainMenu
Endif
Endif
' REMOVE ALL THE FOLLOWING LINES UP TO THE LINE *****
' BECAUSE THERE IS NO NEED TO HYBERNATE ON THE NEPTUNE CABLE
' ALL LINE WITH COMMENT SYMBOL PLUS * WERE ORGINALLY COMMANDS
' Calculate how much time we have to wait for next Cycle
' If in Minute Mode, wait for next whole minute
' *IF MinOrSec = 1 HibernateTime = 60 -?(0)
' If in Second Mode, Wait for next Cycle time
' Do not Hibernate if in Second mode & CycleTime < 15 sec
' Print "MinOrSec = ",MinOrSec
' Print "BrtTimeSec = ",BrtTimeSec
' *IFF MinOrSec = 0
'   Print "Inside If Loop"
' *   IF CycleTime < 15 GOTO CheckTime
' *   HibernateTime = BrtTimeSec -?(0)
' Check for change of Minute
' *   If HibernateTime < 0 HibernateTime = HibernateTime + 60
' Never allow an unreasonable Hibernate Time
' *   If HibernateTime > CycleTime Goto CheckTime
' *Endif
' Print "MinOrSec = ", MinOrSec
' Print "HibernateTime = ", HibernateTime
' The Next make no sense so I am removing it
' IF?(0) >= 59 GOTO Wait
' Only Hibernate if there is extra time
' *IFF HibernateTime > 8
' Provide 4 second count downtime
' *   HibernateTime = HybernateTime - 4
' *   IFF Verbose = 1
' *   Print "   Hyberating for ",HibernateTime," Seconds."
' *   Endif
' Hibernate until we are close to next whole minute
' Hibernate for (HibernateTime) seconds
' *   HYB 0: HYB (HibernateTime)
' *ENDIF
' *****
GOTO CheckTime
Wait:
IFF Verbose = 1
PRINT " Current Time = ",#02,?(2),":",?(1),":",?(0);
PRINT " Next Cycle at ",#02, BrtTimeHr,":",BrtTimeMin,":",BrtTimeSec
Endif

```

```

WaitLoop:
' Print "In WaitLoop, BrtTimeSec = ", BrtTimeSec, " Actual Seconds = ", ?(0)
RTIME
IFF MinOrSec = 1
    IF ?(0) <> 0 GOTO WaitLoop
Endif
IFF MinOrSec = 0
    IF ?(0) <> BrtTimeSec GOTO WaitLoop
    GOTO SetupToLog
Endif

CheckTime:
' Print "Checking Time"
' Print BrtTimeHr," ",?(2)," ", BrtTimeMin," ", ?(1)," ", BrtTimeSec," ", ?(0)
IF BrtTimeHr = ?(2) & BrtTimeMin = ?(1) & BrtTimeSec = ?(0) GOTO SetupToLog
' Check if we have missed the right time
IF BrtTimeHr = ?(2) & BrtTimeMin = ?(1) & ?(0) > BrtTimeSec GOTO SetupToLog
IF BrtTimeHr = ?(2) & BrtTimeMin < ?(1) GOTO SetupToLog
GOTO AnotherCycle

UserCommand:
' Check for User Command to Stop Logging (Control-S = 19)
' Be sure KeyCommand word = 0
KeyCommand = 0
' Save Memory Pointer
SavePointer = Pointer
' Save Contents of Memory
SaveData = Get(Pointer,#2)
' Decrement Pointer
Pointer = Pointer - 2
' Be sure Memory is Zero
MemValue = 0
Store Pointer, #1, MemValue
' Backup one memory location
Pointer = Pointer - 1
' Look for Keyboard Entry
Iff Verbose = 1
Print "    Enter Control-S ** NOW ** to Stop.    "
Endif
' Print Current Time
RTIME
Iff Verbose = 1
PRINT " Current Time = ",#02,?(2),":",?(1),":",?(0);
Endif
' Print next cycle time if not in Shipping Mode or Low Battery Mode
If LowBattMode = 1 Print "    Vbatt = ", Vbatt!
IFF LowBattMode = 0 & Verbose = 1
    PRINT " Next Cycle at ",#02, BrtTimeHr,":",BrtTimeMin,":",BrtTimeSec
Endif
' Otherwise Print Date too
IFF Verbose = 1
If LowBattMode = 1 PRINT "    Date = ",#02,?(4),"/",?(3),"/",?(5)
Endif
ITEXT Pointer, 80
' If character stored, adjust memory size
IFF Pointer <> SavePointer
    Pointer = SavePointer
' Get the Keyboard entry
KeyCommand = GET(Pointer, #1)
' Restore Pointer

```

```

    Pointer = SavePointer
ENDIF
' Restore Original Memory
Store Pointer, #2, SaveData
' Decrement Pointer
Pointer = Pointer - 2
return

SetupToLog:
' Check for User command to Stop
GOSUB UserCommand
IFF KeyCommand = 19
    Goto MainMenu
Endif
IFF Verbose = 1
Print
Print "Starting to log a burst of Data to memory."
Endif
' Turn on TPU Processor
TPUon()
' Turn on Analog Power
PSET 0
' Turn on Sensor Power
SDO PwrWord, 16
' Wait a little for power to stabilize
SLEEP 0: SLEEP 400
' Reset Mux
PSET 1
Sleep 0: Sleep 10
Pclr 1
' Move Mux to Battery Channel (Mux2)
For I = 1 to 2
Pset 1: Pclr 1
' Wait for Mux to stabilize
Sleep 0: Sleep 10
Next I
CheckBattery:
' Check the Battery Voltage
' Take 10 values and average
Vave! = 0
BatSum = 0
For I = 1 to 10
Raw = Chan(7)
BatSum = BatSum + Raw
Vbatt! = (40.96*Raw/65536)
Vave = Vbatt + Vave
next I
Vbatt = Vave/10
IFF Verbose = 1
print
print "The Battery voltage is ";
print #5.3F, Vbatt;
print " Volts."
Endif

StartBurst:
IFF Verbose = 1
Print
!*****

```

```

' Print Header
IFF HeaderStatus = 0
Print "Res/5  ResX1  ResX5  *H2/5  *H2X1  *H2X5  *eH**  Ref-T  Ref-T  Res-T
Res-T  Vbatt"
Print "Volts  Volts  Volts  Volts  Volts  Volts  Volts  Volts  Deg-C  Volts
Deg-C  Volts"
HeaderStatus = 1
Endif
Endif
'Reset Mux
Pset 1
Sleep 0: Sleep 10
Pclr 1
' Read the starting time
RTIME
' Get Res, Hydrogen, Ref Temp Data and Average (10 values)
Res1Ave = 0
Res2Ave = 0
Res3Ave = 0
H1Ave = 0
H2Ave = 0
H3Ave = 0
EhAve = 0
RefTempAve = 0
Sleep 0
For I = 1 to 10
Res1Ave = Res1Ave + Chan(0)/16
Res2Ave = Res2Ave + Chan(1)/16
Res3Ave = Res3Ave + Chan(2)/16
H1Ave = H1Ave + Chan(3)/16
H2Ave = H2Ave + Chan(4)/16
H3Ave = H3Ave + Chan(5)/16
EhAve = EhAve + Chan(6)/16
RefTempAve = RefTempAve + Chan(7)/16
Next I
Res1Ave = Res1Ave/10
Res2Ave = Res2Ave/10
Res3Ave = Res3Ave/10
H1Ave = H1Ave/10
H2Ave = H2Ave/10
H3Ave = H3Ave/10
EhAve = EhAve/10
RefTempAve = RefTempAve/10
' *****
' Note all A/D data is divided by 16
' Since it is only 12 but data shifted into 16 bits
' This helps to identify the BOF Markers later!
' *****
Volts! = Float(Res1Ave)/1000
Print #5.3F,Volts;
Print " ";
Volts = Float(Res2Ave)/1000
Print #5.3F,Volts;
Print " ";
Volts = Float(Res3Ave)/1000
Print #5.3F,Volts;
Print " ";
Volts! = Float(H1Ave)/1000
Print #5.3F,Volts;

```

```

Print " ";
Volts = Float(H2Ave)/1000
Print #5.3F,Volts;
Print " ";
Volts = Float(H3Ave)/1000
Print #5.3F,Volts;
Print " ";
Volts = Float(EhAve)/1000
Print #5.3F,Volts;
Print " ";
Volts = Float(RefTempAve)/1000
Print #5.3F,Volts;
Print " ";
' Convert Reference Thermistor Value
ThermistorMVolts = RefTempAve
ThermistorVolts! = Float(ThermistorMVolts)/1000
Gosub ConvertThermistorTemp
Print " ";
' Save Thermistor Temp too
' Need to convert it to mC * 10
' so it is same format as Thermocouple
Tmp = INT(P!*100.)
' Get Thermocouple Temp
' Move Mux to Next Channel
Pset 1: Pclr 1
' Wait for it to stabilize
Sleep 0: Sleep 10
' Take 10 values of Res Temp and average
ResAveTemp = 0
For I = 1 to 10
ResAveTemp = ResAveTemp + Chan(7)/16
Next I
ResAveTemp = ResAveTemp/10
Volts = Float(ResAveTemp)/1000
Print #5.3F,Volts;
Print " ";
ThermoMVolts = ResAveTemp
ThermoVolts! = Float(ThermoMVolts)/1000
Gosub ConvertThermoTemp
Print " ";
' Save Thermocouple Temp too
' Need to convert it to mC * 10
' so it is not too big to store
Tmp = INT(T!*100.)
' Already Have Battery Voltage so just print it
Print #4.1F, Vbatt;
Print
' Turn power off to sensors
SDO 0, 16
' Turn off Analog Power
Pclr 0

DoneLogging:
Iff Verbose = 1
Print
Print "                Memory Pointer = ",Pointer
Print
Endif

```

```

ThisCycleIsDone:
'*****
TPUoff()
' Update PrevHour Variable
PrevHour = ?(2)
Goto CalNextBurstTime

' Subroutine to convert A/D value ThermistorVolts & print Temp in Degrees C
' Thermistor voltage (Volts) = Y
' Thermistor Temp (C) = P = 27.50133 - (17.2658*Y) + 15.83424/Y
ConvertThermistorTemp:
Y! = ThermistorVolts
' Do not allow Thermistor voltage to be zero or very small
IF Y < 0.5 Y = 0.5
P! = 27.50133 - (17.2658*Y) + 15.83424/Y
Print #4.2F, P;
RETURN

' Subroutine to convert A/D value ThermoMVolts & print Sensor Temp in Degrees
C
' Thermocouple Voltage (Volts) = E = ThermoVolts
' Thermocouple Temp (C) = K = (244970*E)/1000
' Corrected Sensor Temp (C) = T = Th + P
ConvertThermoTemp:
E! = (ThermoVolts)
Th! = (244970*E)/1000
T! = Th + P
Print #5.1F, T;
RETURN

ErrorRoutine:
' Go here in case of a problem with the Software, so can try to recover
' Turn everything off
Gosub TurnOffEverything
Print
Print
Print "          ***** WARNING !!!
*****"
Print
Print "          There has been a problem with the Software!"
Print "          and this program is attempting to recover."
Print
print "          Turning all sensor power off."
print
GOTO CalNextBurstTime

TurnOffEverything:
' Note the following are reverse logic
PSET 6, 9, 10, 11, 12, 15
' Turn off all sensor power
SDO 0, 16
' Turn off analog power
Pclr 0
ADoff()
TPUoff()
RETURN

CharCount = 0
DecodeLoop:

```

```

Char = Get(DecodeMem,#1)
' Print "The character = ", Char
' Input "Waiting " A
If Char = 13 goto Convert
' If the character is not a real number (48 to 57), ignore it
If Char < 48 goto DecodeLoop
If Char > 57 goto DecodeLoop
CharCount = CharCount + 1
D(CharCount) = Char - 48
Goto DecodeLoop
Convert:
' Convert the Data
' For I = 1 to CharCount
'     Print "D(",I,") = ", D(I)
' Next I
NumBlocks = 0
IFF CharCount = 1
    NumBlocks = D(1)
    Return
ENDIF
For I = 1 to (CharCount)
    GOSUB PowerofTen
    NumBlocks = PwrTen * D(I) + NumBlocks
Next I
Return

PowerofTen:
' Routine to get powers of 10
PwrTen = 1
For J = 1 to (CharCount-I)
    PwrTen = 10 * PwrTen
Next J
Return

InputErrors:
' Input Error Routine
PRINT ""
PRINT "                The value you have entered is not within valid limits!"
PRINT "                Please Try Again!"
PRINT " "
PRINT "                Press ENTER to Continue."
INPUT ""A
RETURN

ClearScreen:
' Clear the screen
FOR I = 1 TO 50
PRINT
NEXT I
RETURN

Finish:
' **This routine is not used on the Canadian Version
' Stop the program
' Turn Off Everything
GOSUB TurnOffEverything
STOP

```

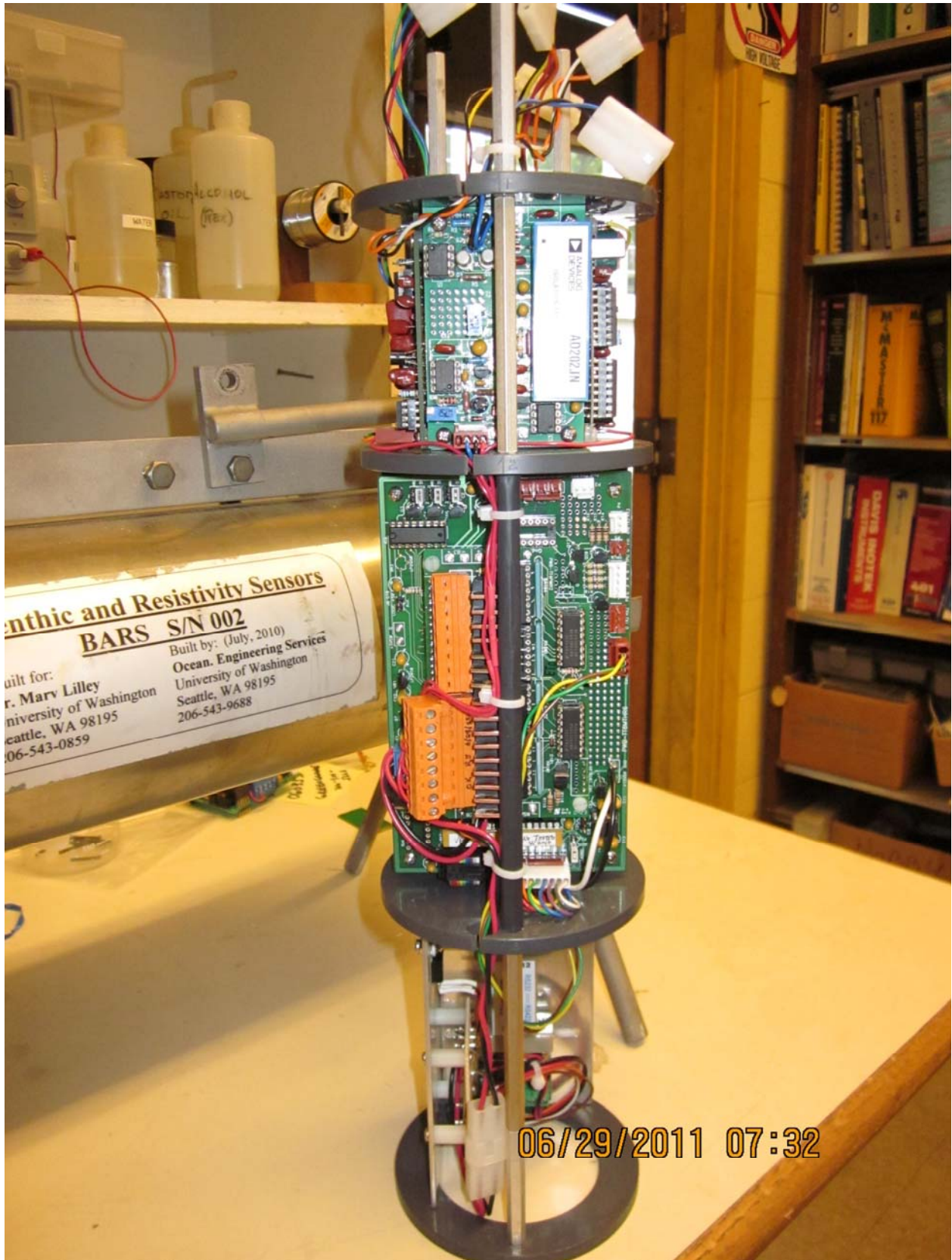

Section 3

System Schematics

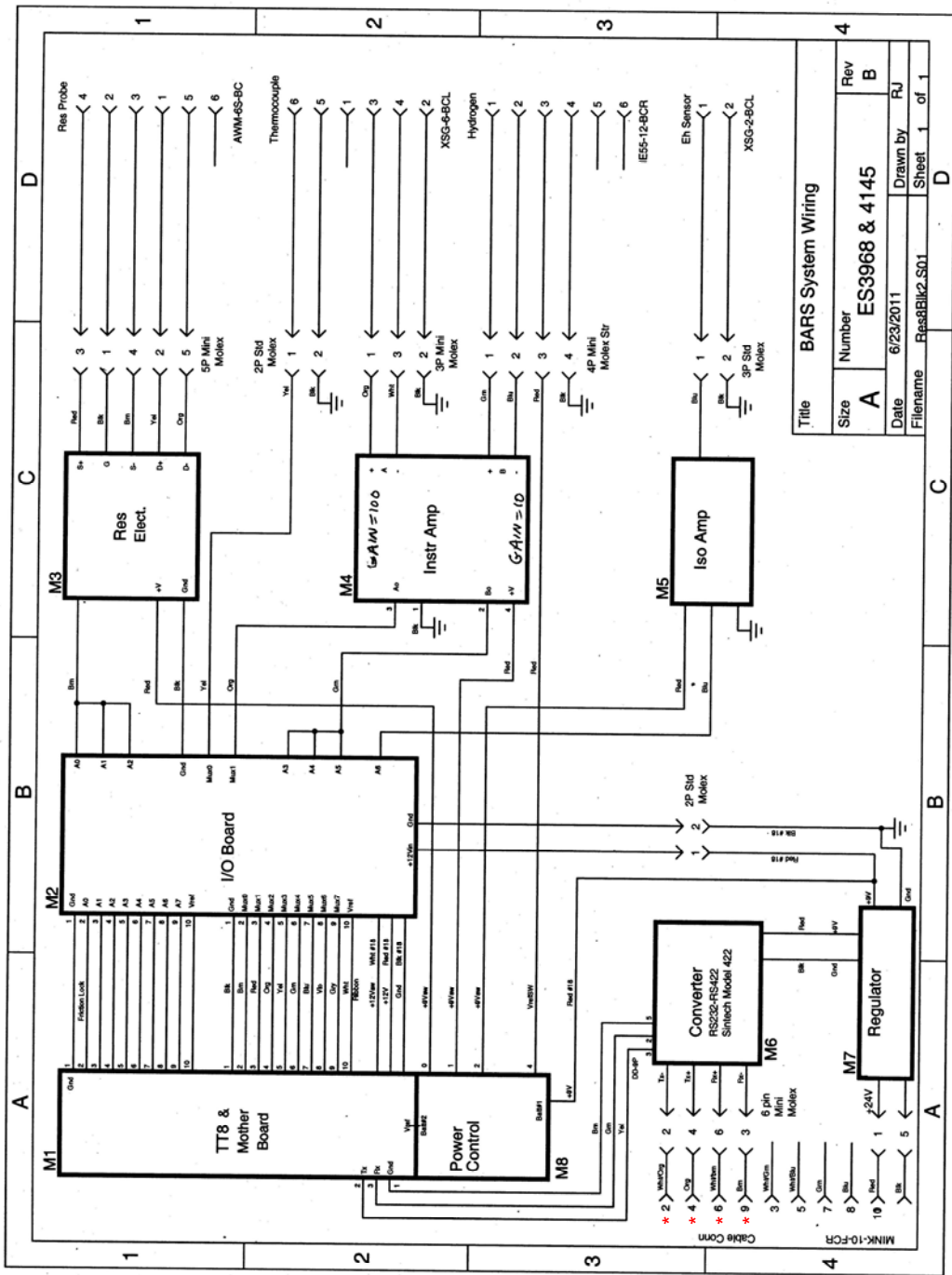

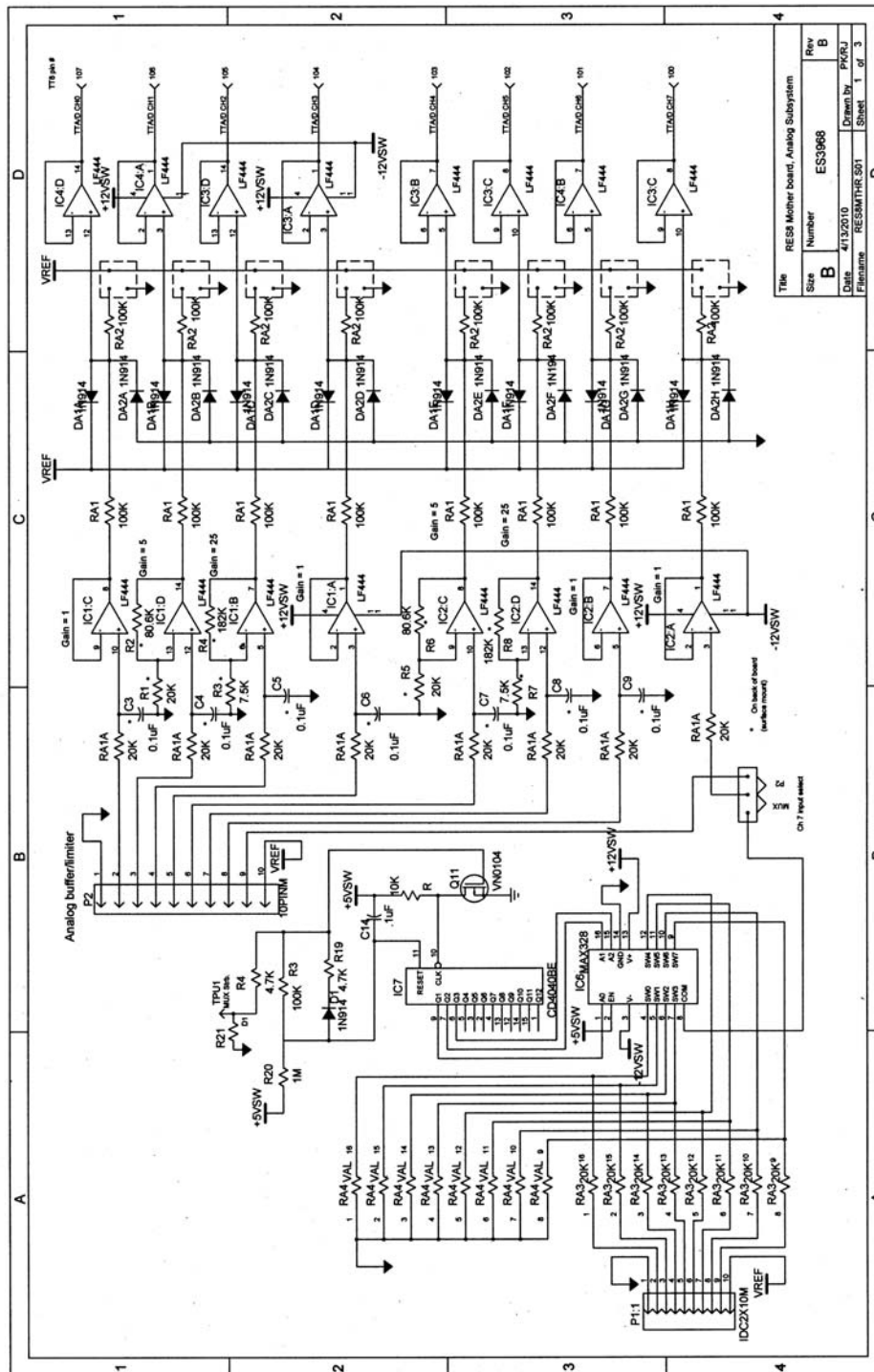

***NOTE:** Starting in May 2019, the MINK pinout will be modified. RS-422 Transmit and Receive pins will be swapped in the instrument. This will make BARS instruments compatible with standard PBOF cables used by ONC (ODI P/N 1048181, 1048184, 1093189). BARS specific cables will remain compatible.



Title	RES8 Mother board, Analog Subsystem
Size	Number
B	ESS3968
Rev	B
Date	4/13/2010
Drawn by	PKRJ
Filename	RES8MTR.S01
Sheet	1 of 3

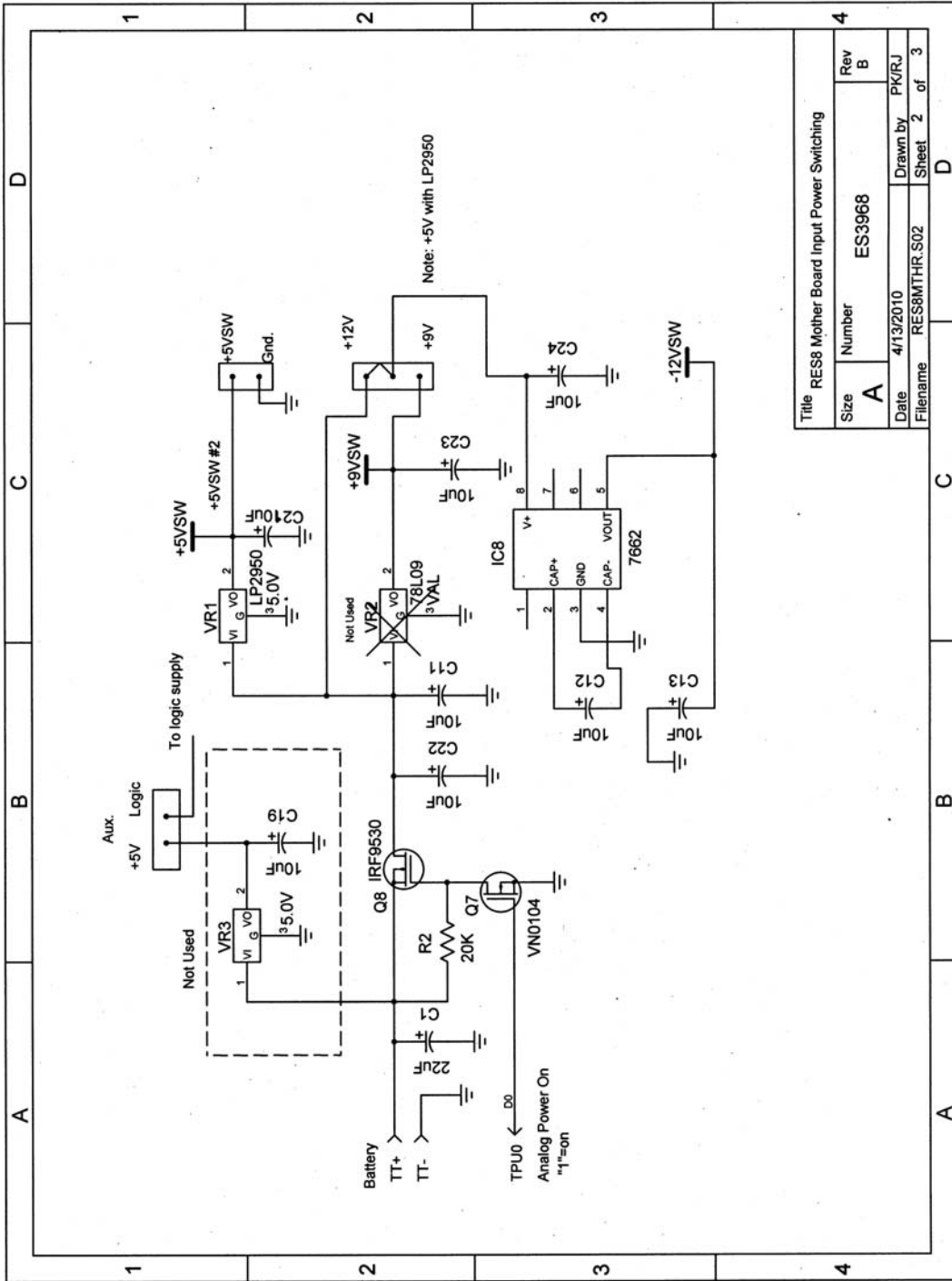

Title RES8 Mother Board Input Power Switching			
Size	Number	Rev	Rev
A	ES3968	B	B
Date	4/13/2010	Drawn by	PK/RJ
Filename	RES8MTHR.S02	Sheet	2 of 3

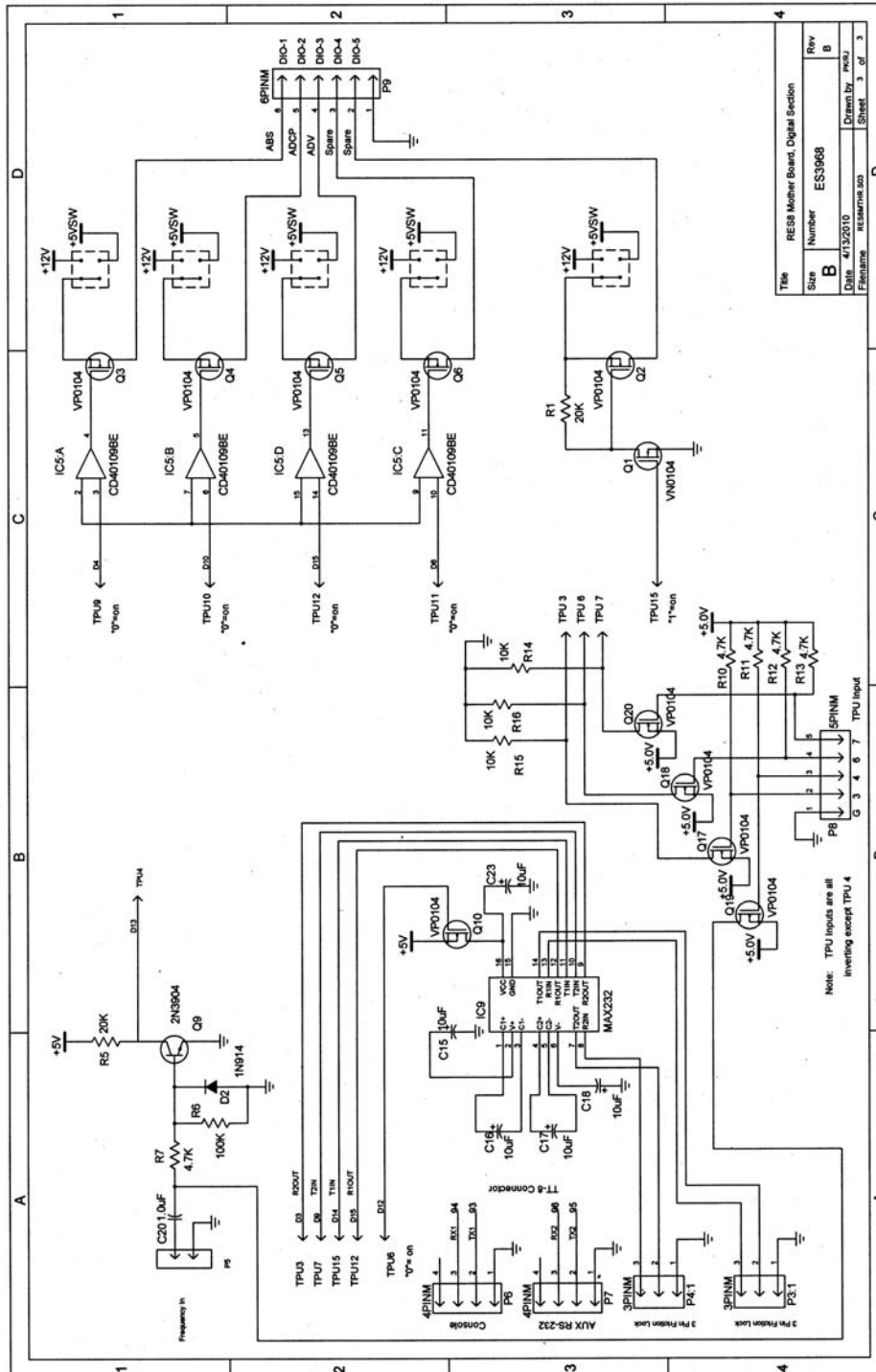

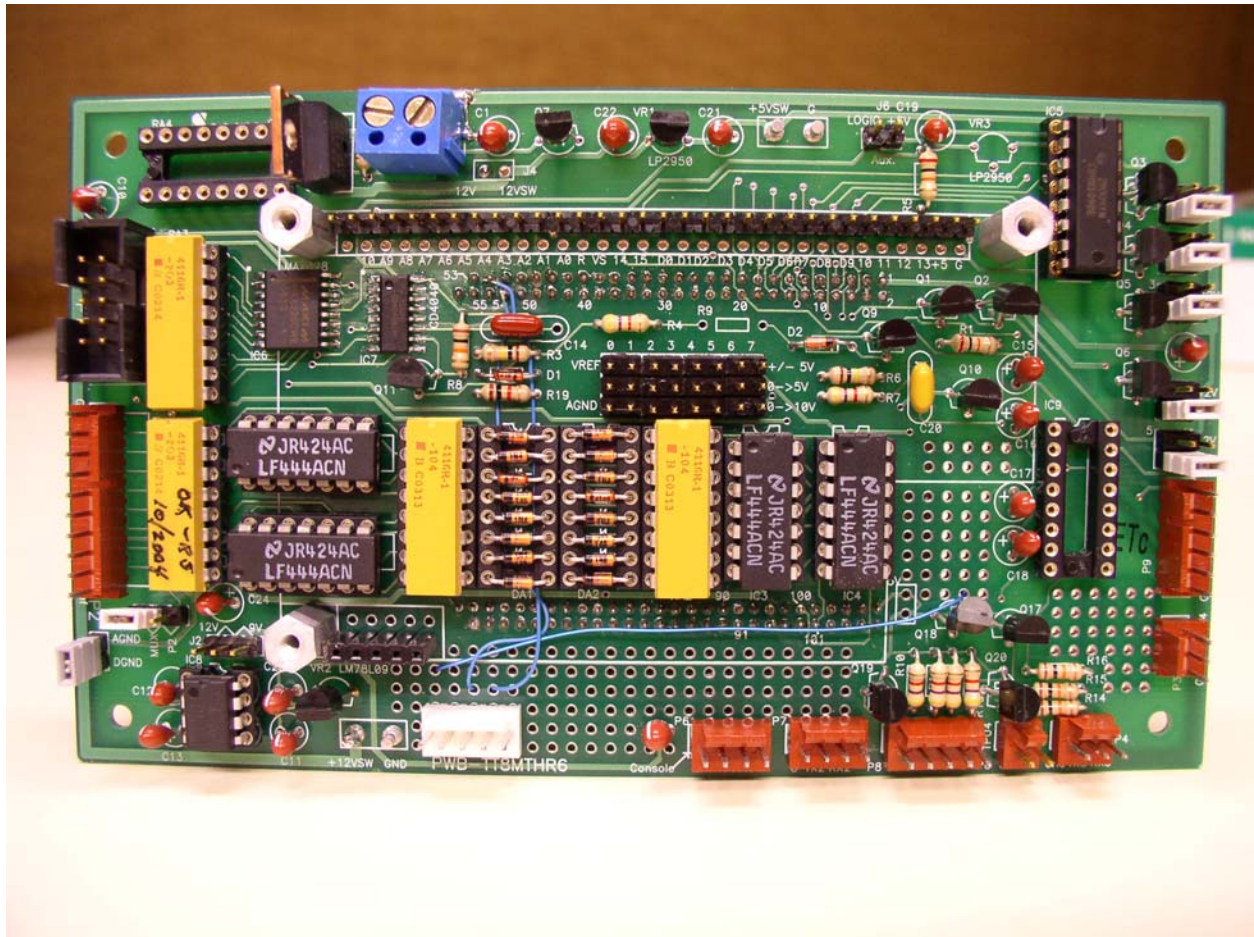

BARS Motherboard – Component Side

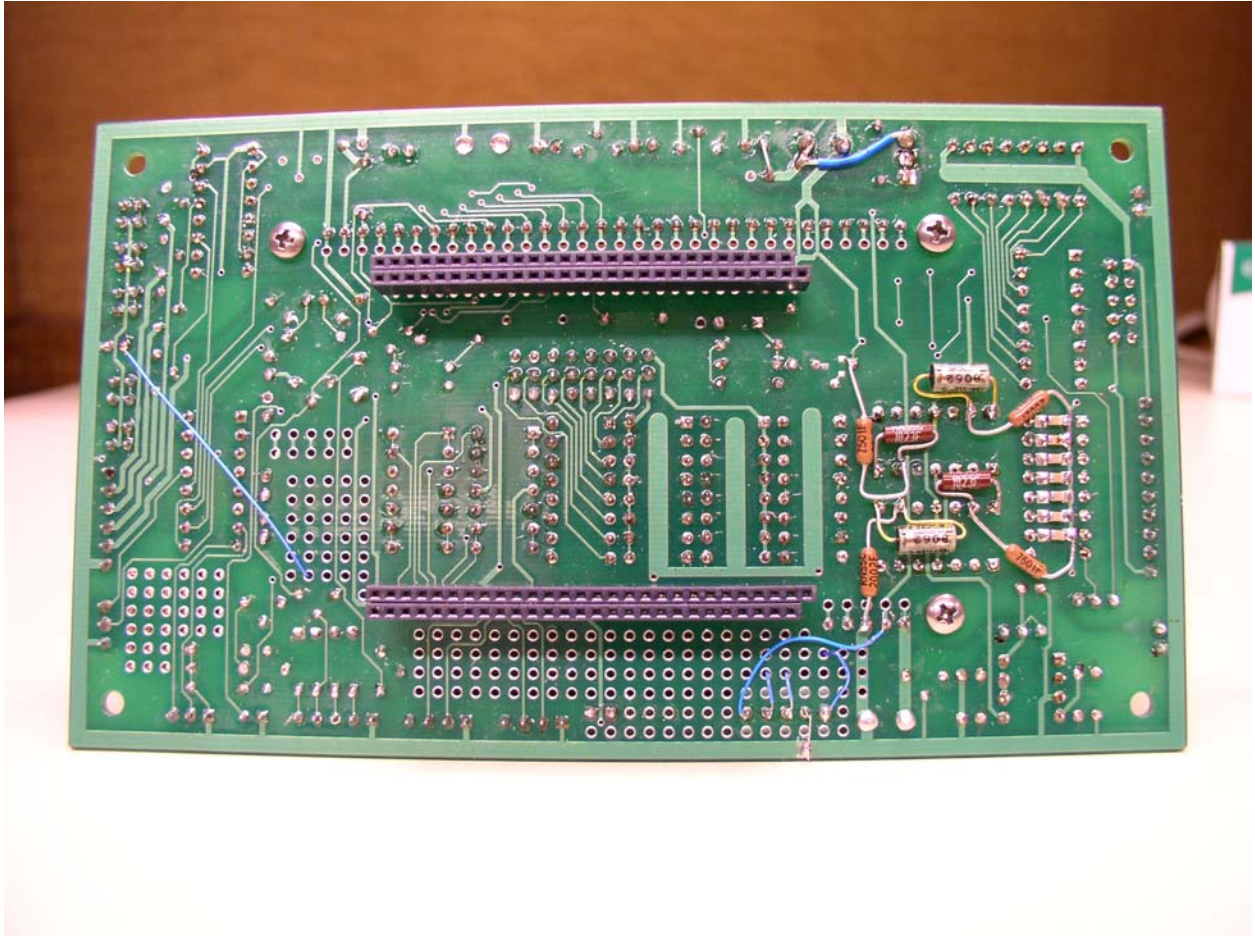

BARS Motherboard – Back side

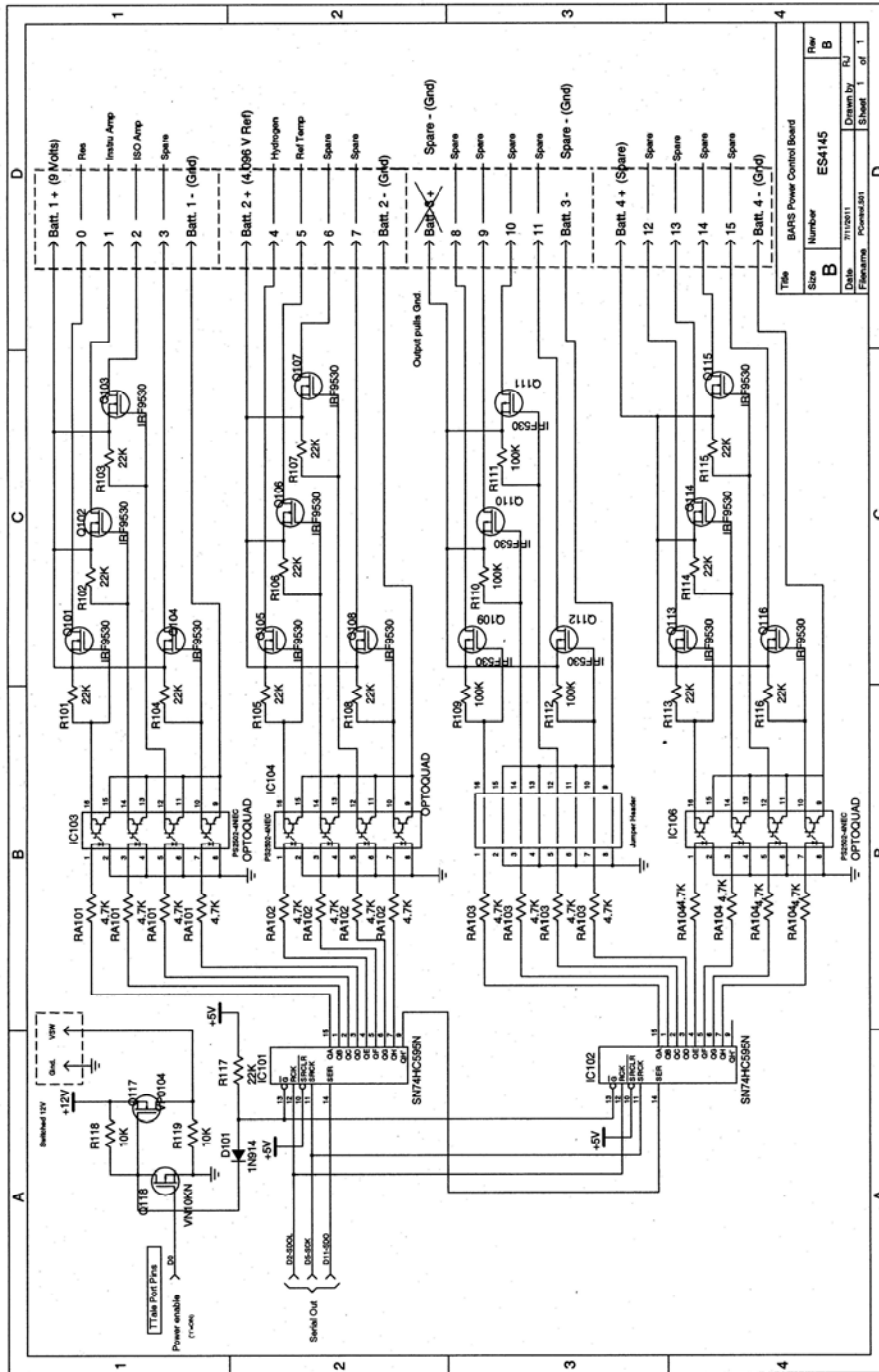

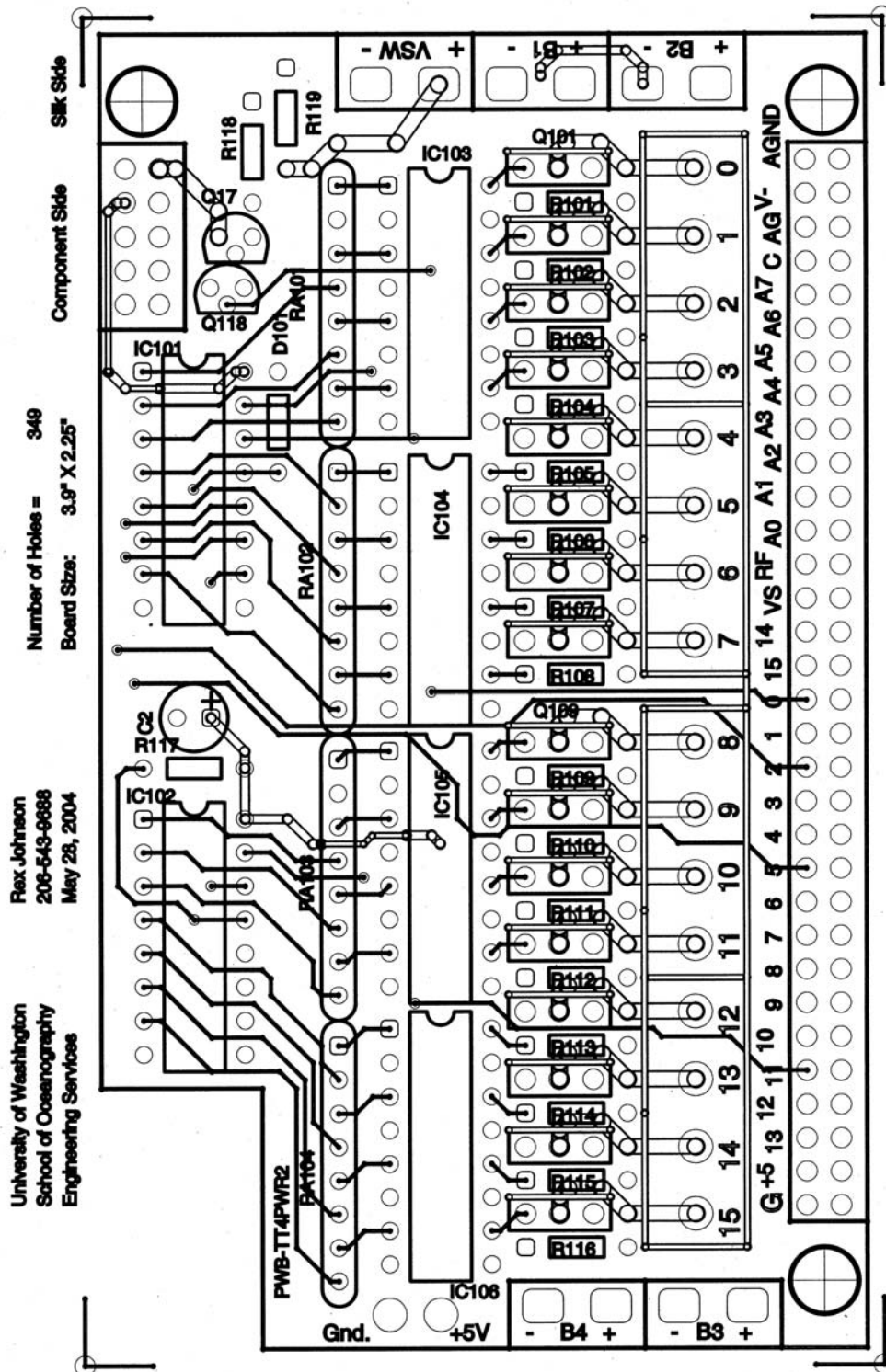

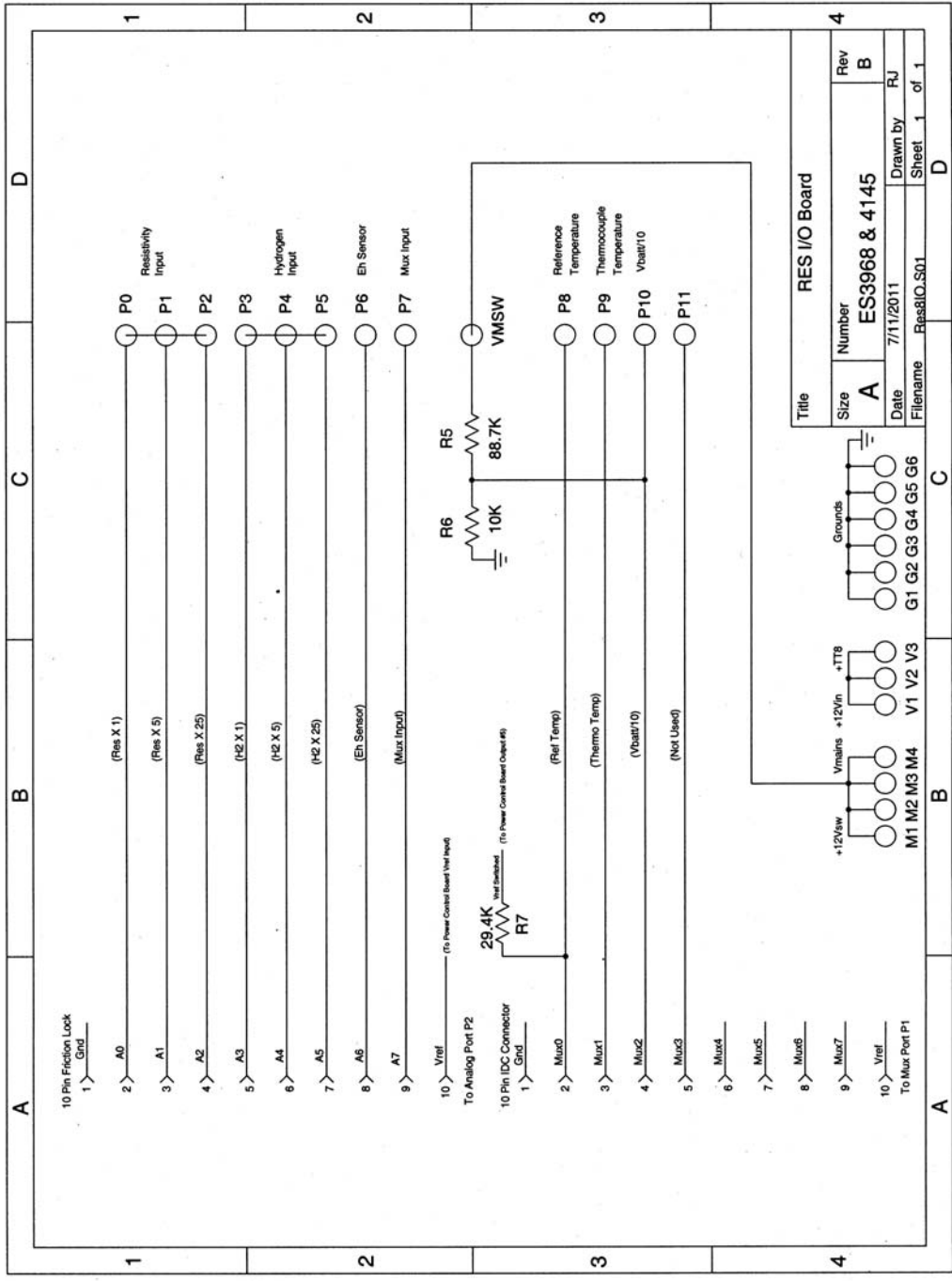

Title			
Size	Number	Rev	
A	ES3968 & 4145	B	
Date	7/11/2011	Drawn by	RJ
Filename	Res8IO_S01	Sheet	1 of 1

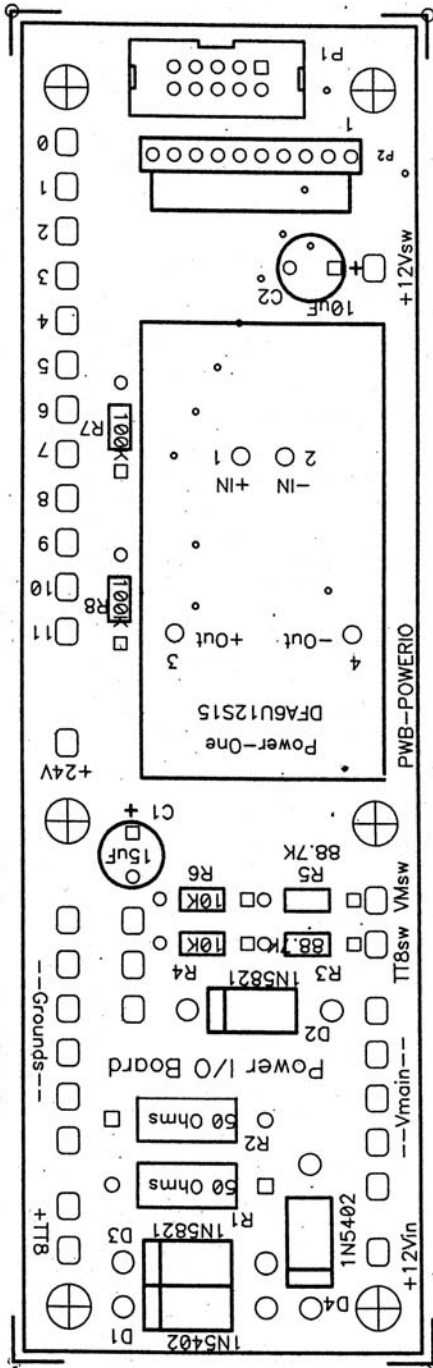

Number of Holes = 108
 Board Size: 6.8" X 1.8"

University of Washington
 School of Oceanography
 Engineering Services
 Rex Johnson
 286-543-9688
 May 28, 2004

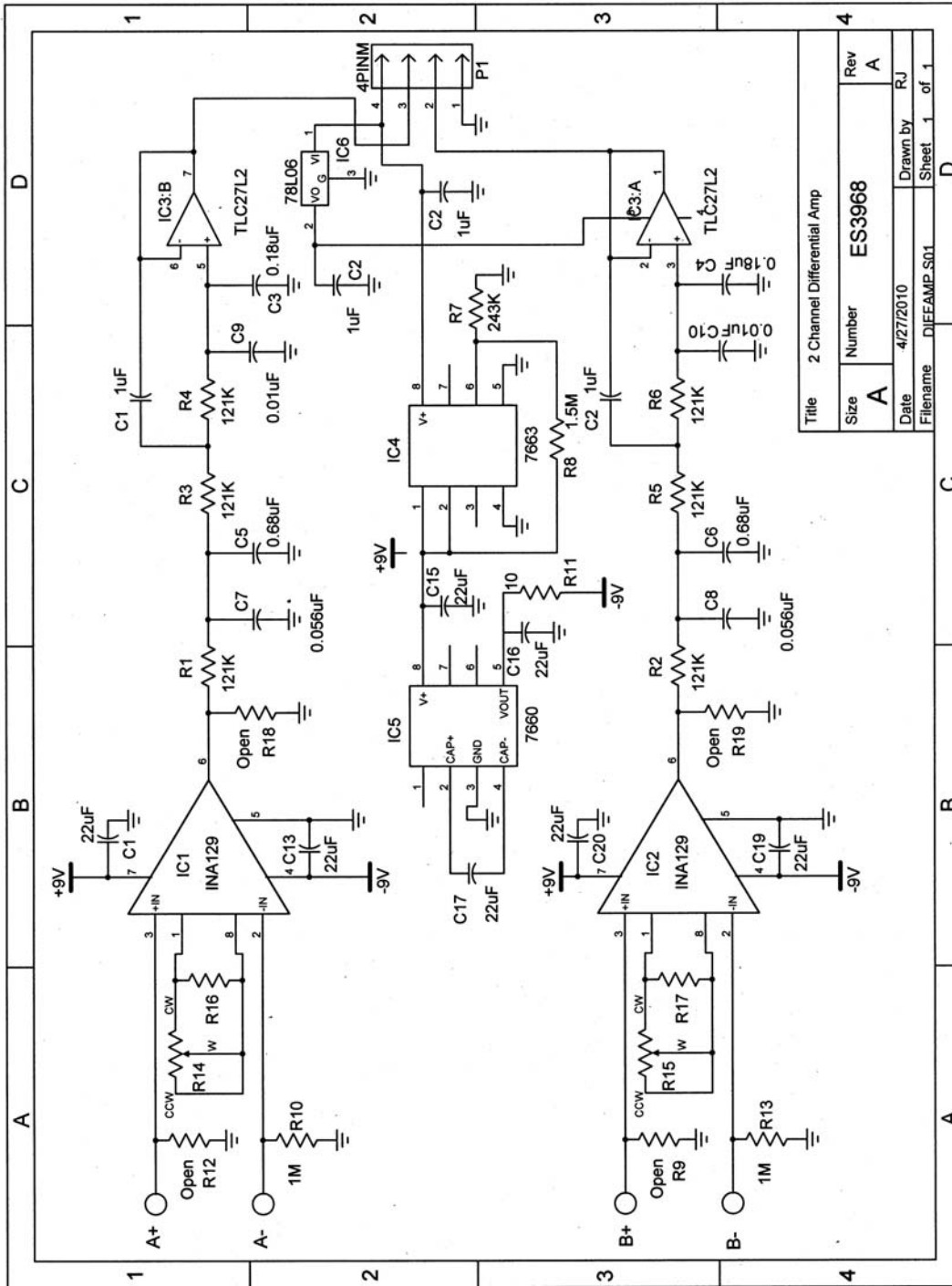

Title 2 Channel Differential Amp			
Size A	Number ES3968	Rev A	
Date 4/27/2010	Drawn by RJ	Sheet 1	of 1
Filename DIFAMP.S01			

Engineering Services

Rex Johnson
206-543-9688
July 6, 2004

Number of Holes = 145
Board Size: 2" X 2.95"

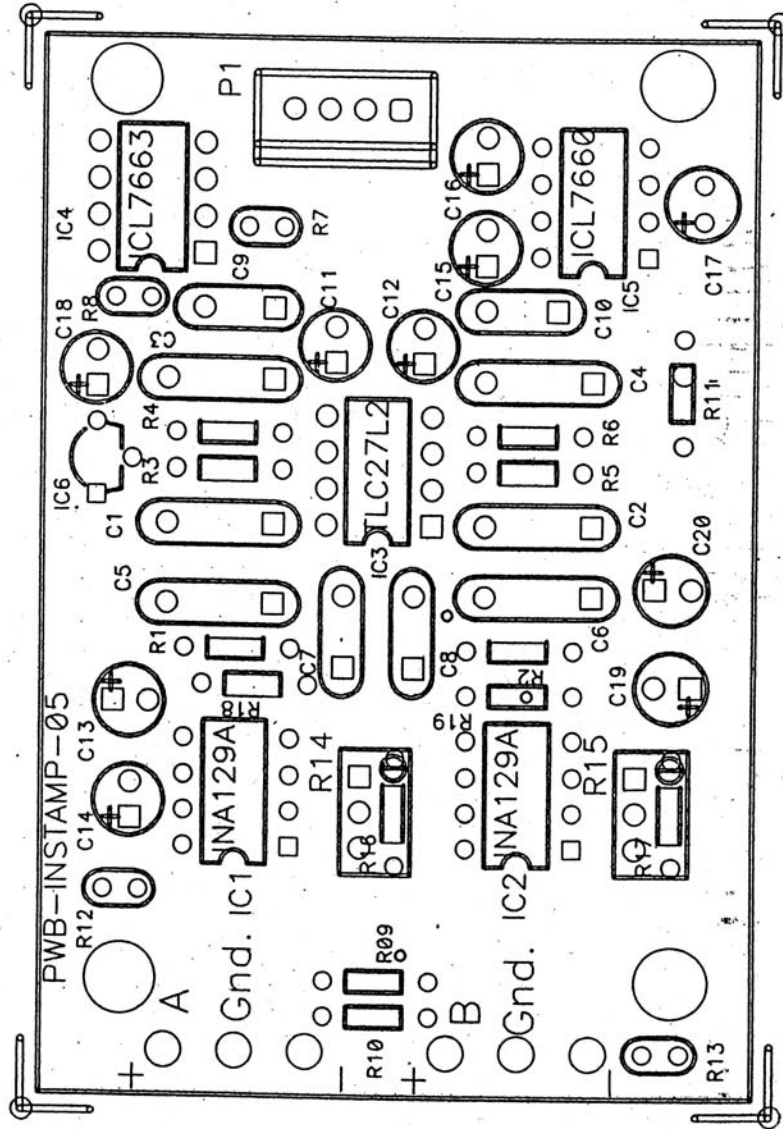

eH Isolation Amplifier Schematic Rev 1.1
Adapted from previous design
Current as of 7/8/10
Grayson Dietrich

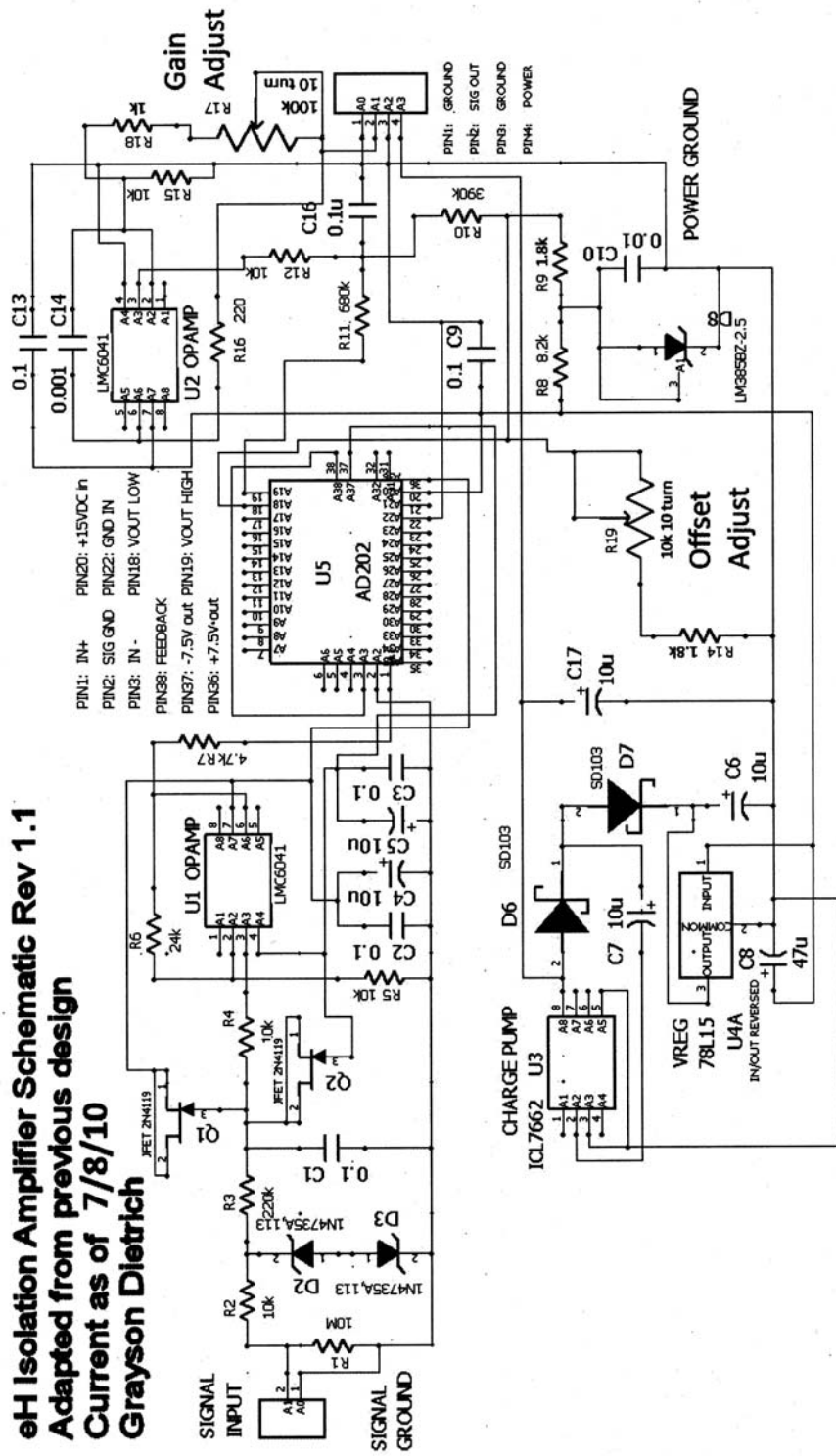

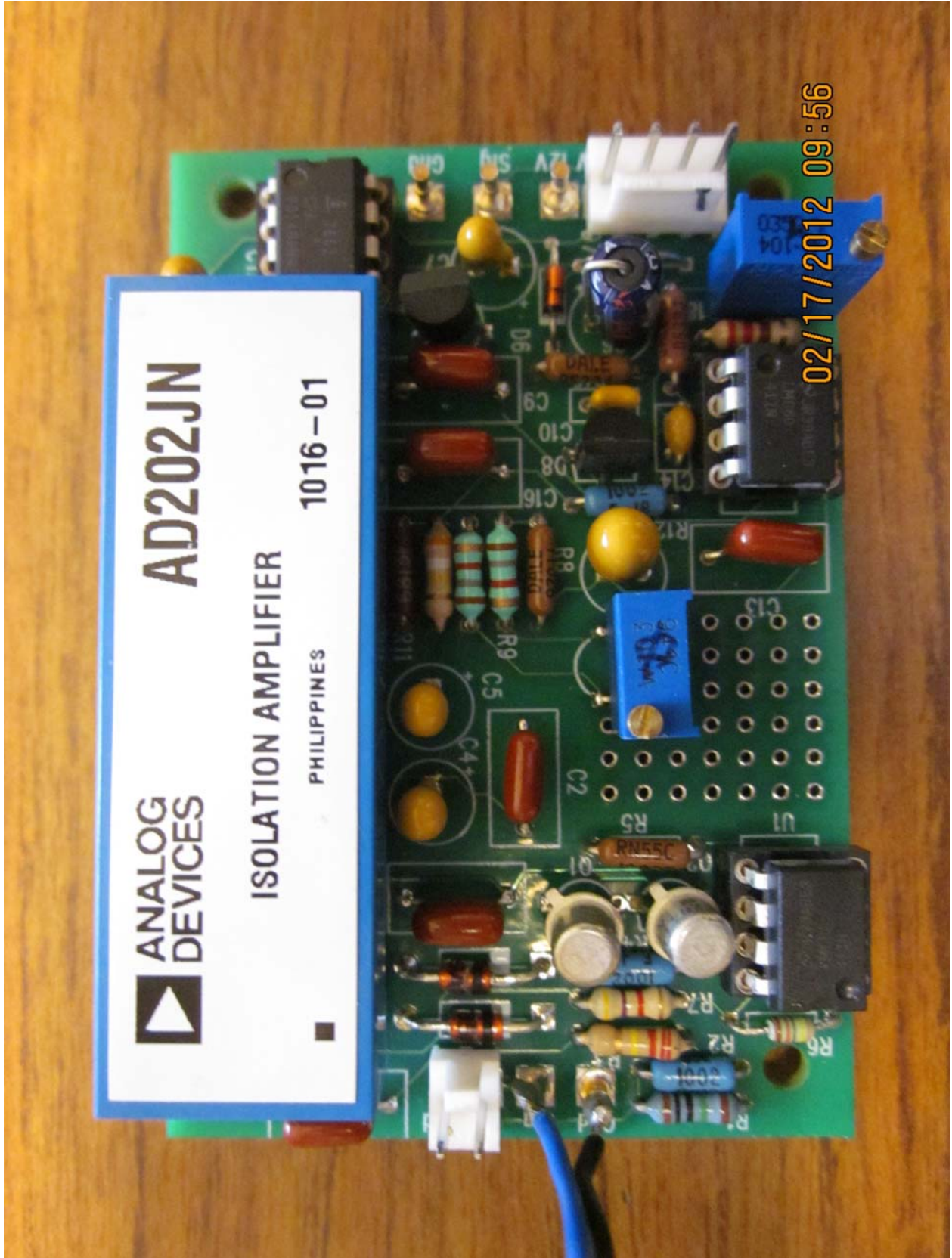

**ANALOG
DEVICES**

AD202JN

ISOLATION AMPLIFIER

PHILIPPINES

1016-01

02/17/2012 09:56

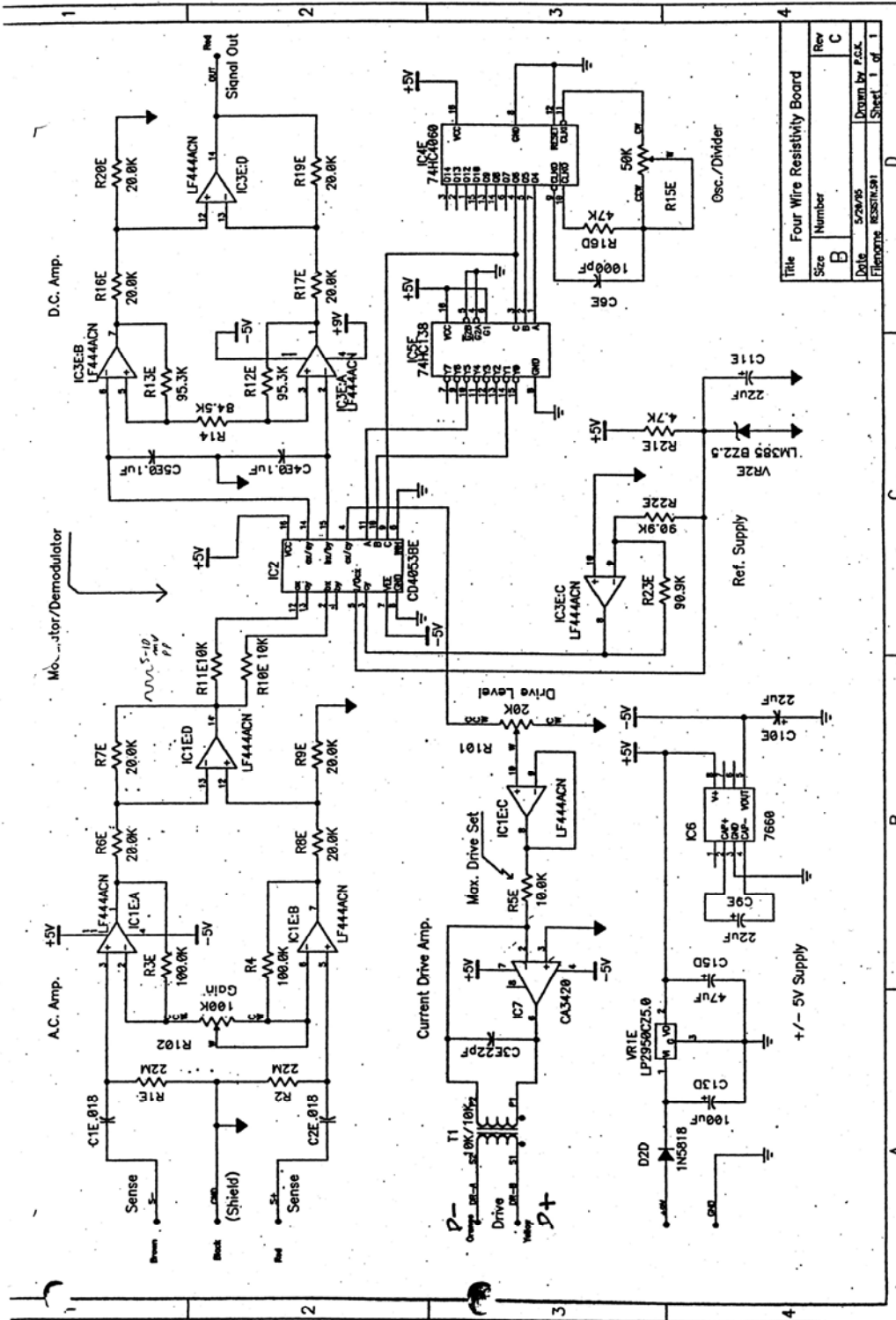

Title		Four Wire Resistivity Board	
Size	Number	Rev	C
B		Drawn by	P.C.K.
Date	5/28/85	Filename	RESM51.S1
		Sheet 1 of 1	

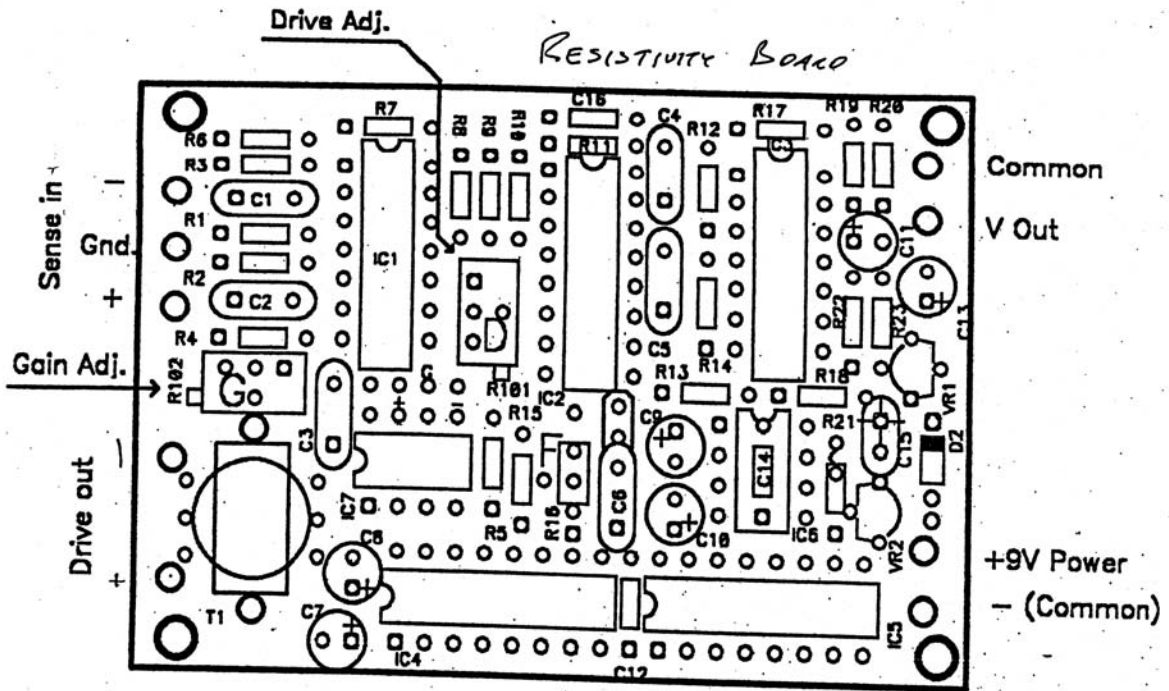

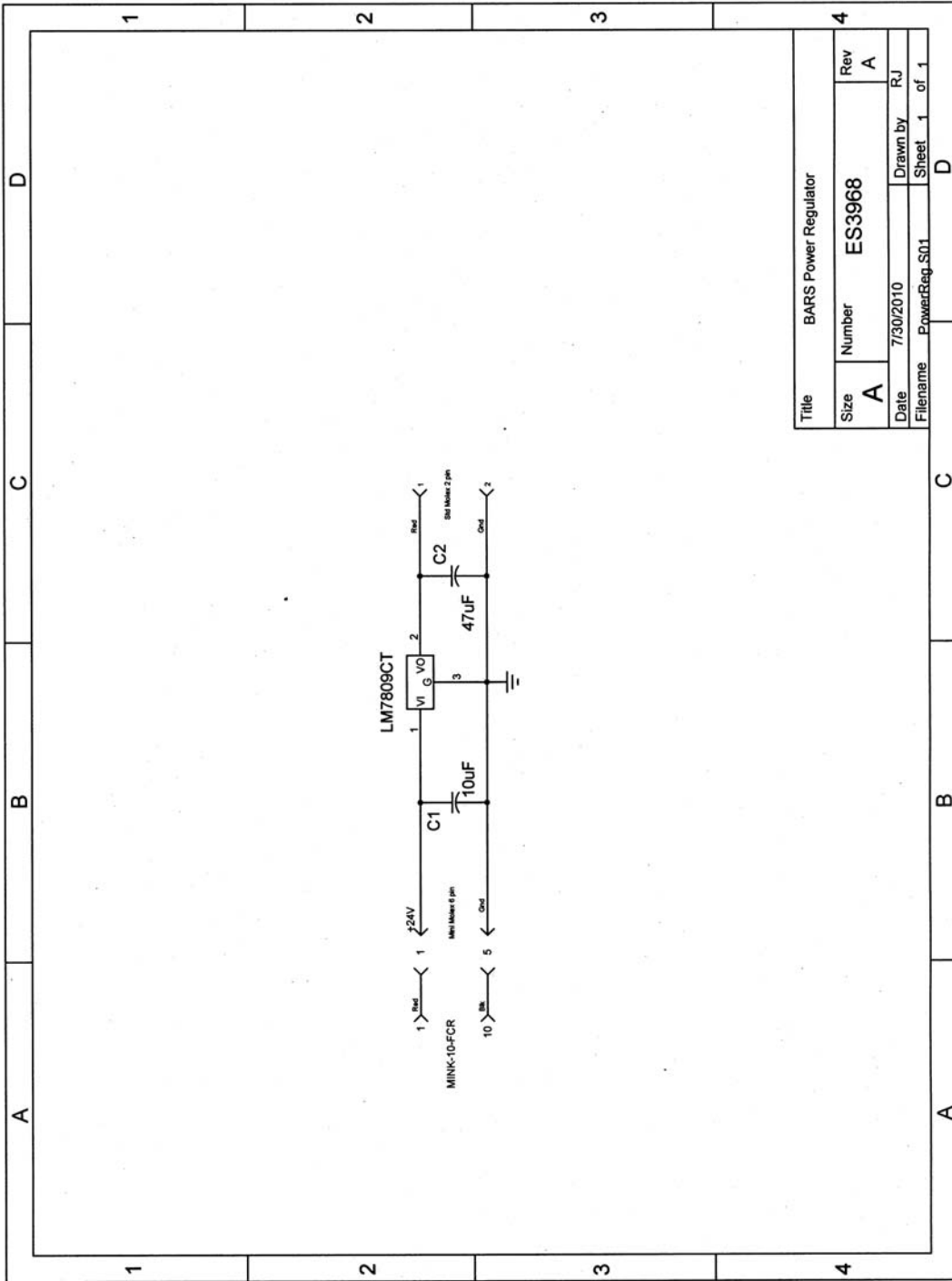

Title				BARS Power Regulator			
Size	Number	ES3968	Rev	A			
Date	7/30/2010		Drawn by	RJ			
Filename	PowerReg.S01		Sheet	1 of 1			

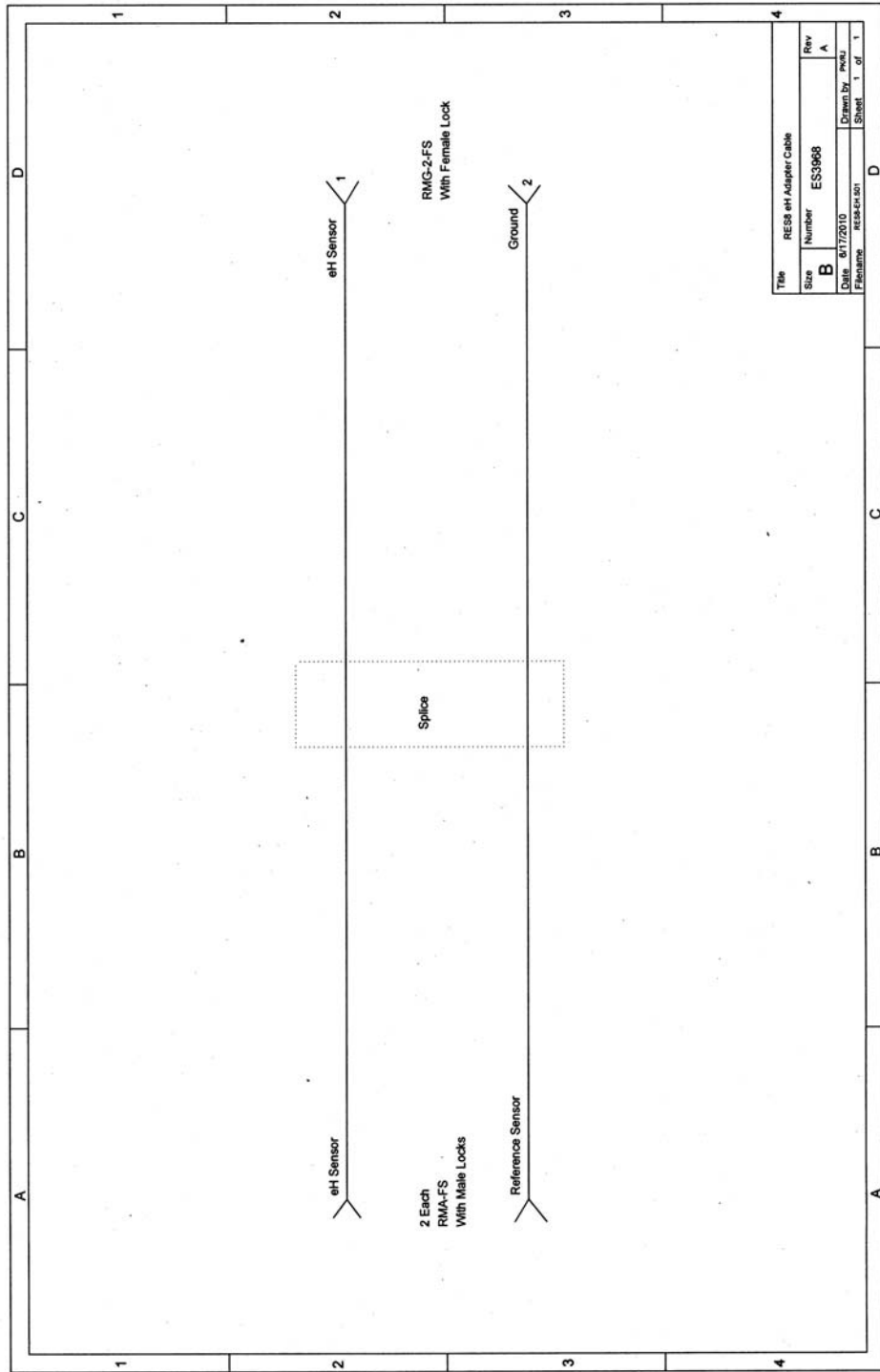

Title	RES8 eH Adapter Cable		
Size	Number	Rev	
B	ES3968	A	
Date	01/17/2010	Drawn by	pwou
Filename	res8-eh-01	Sheet	1 of 1

NEW RES PROSE CABLE
JULY 2003

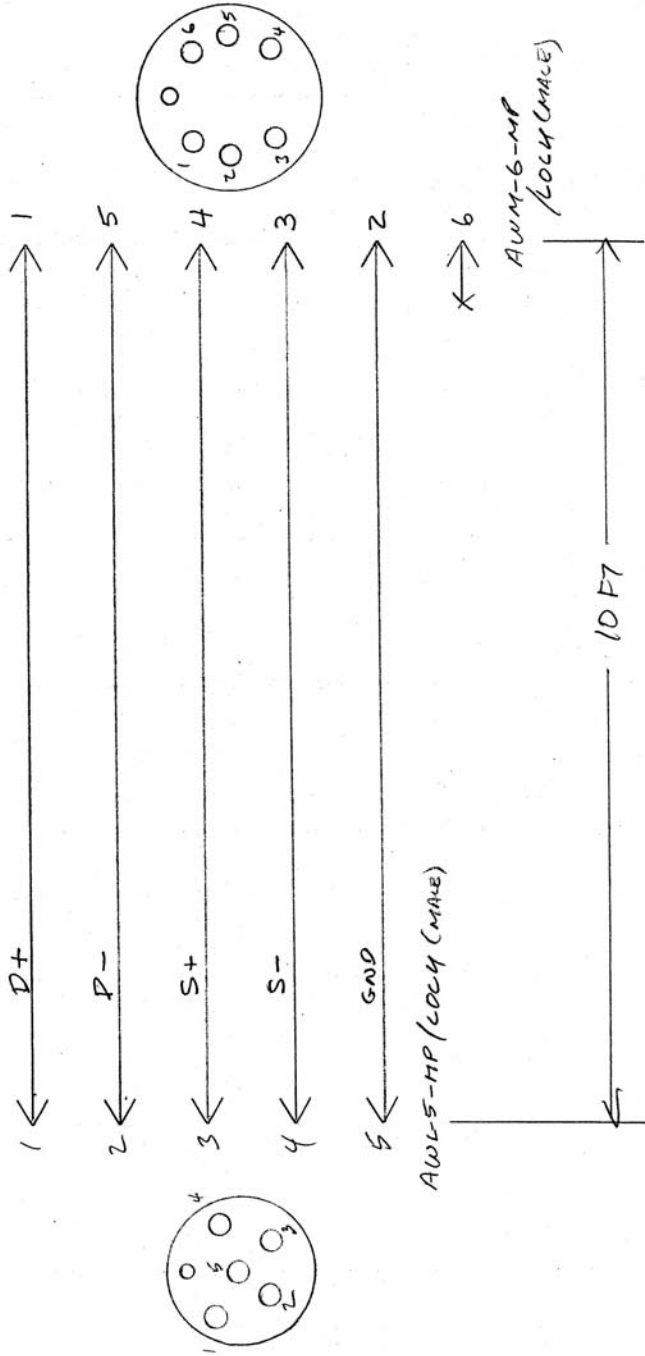

Sup plm
7/9/2003

Section 4

System Mechanical Drawings



TT8 RES LOGGER
LAYOUT

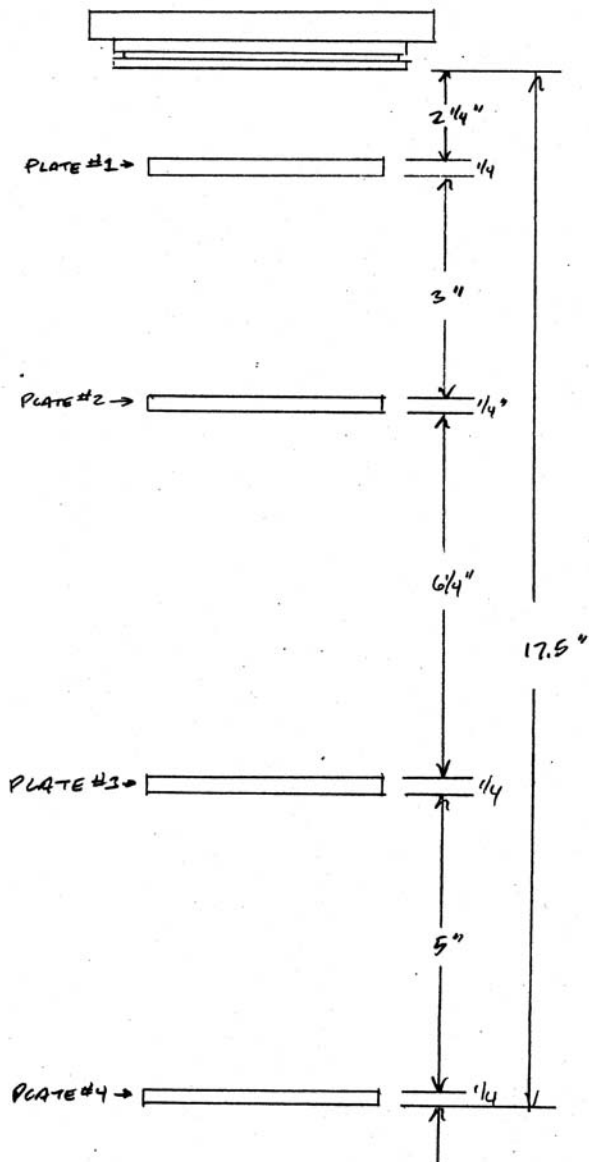

T78 RES LOGGER
#1 PLATE

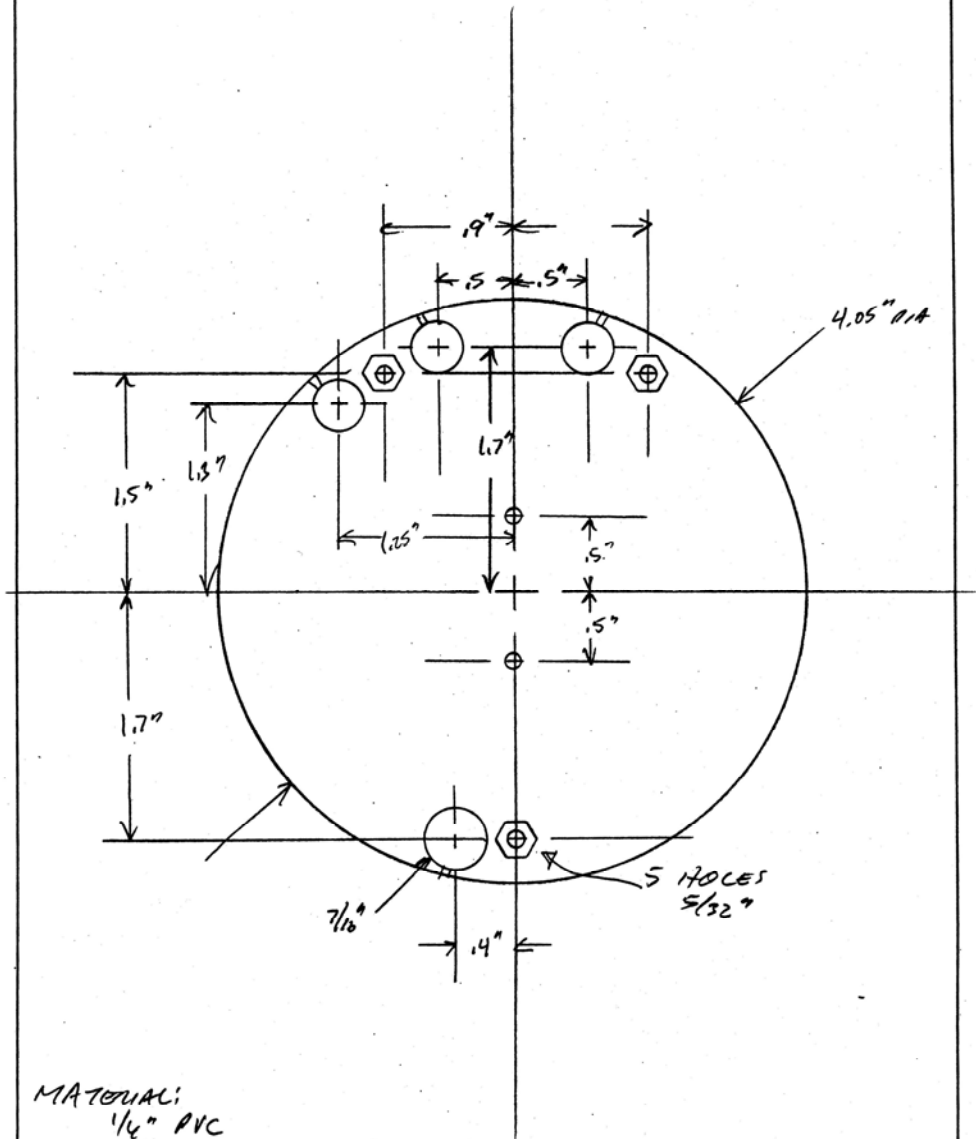

MATERIAL:
1/4" PVC
SCALE:
FULL SIZE
QUANTITY:
1 EA

Rep Johnson
6/20/04

TEB RES LOS402
#2 PLATE

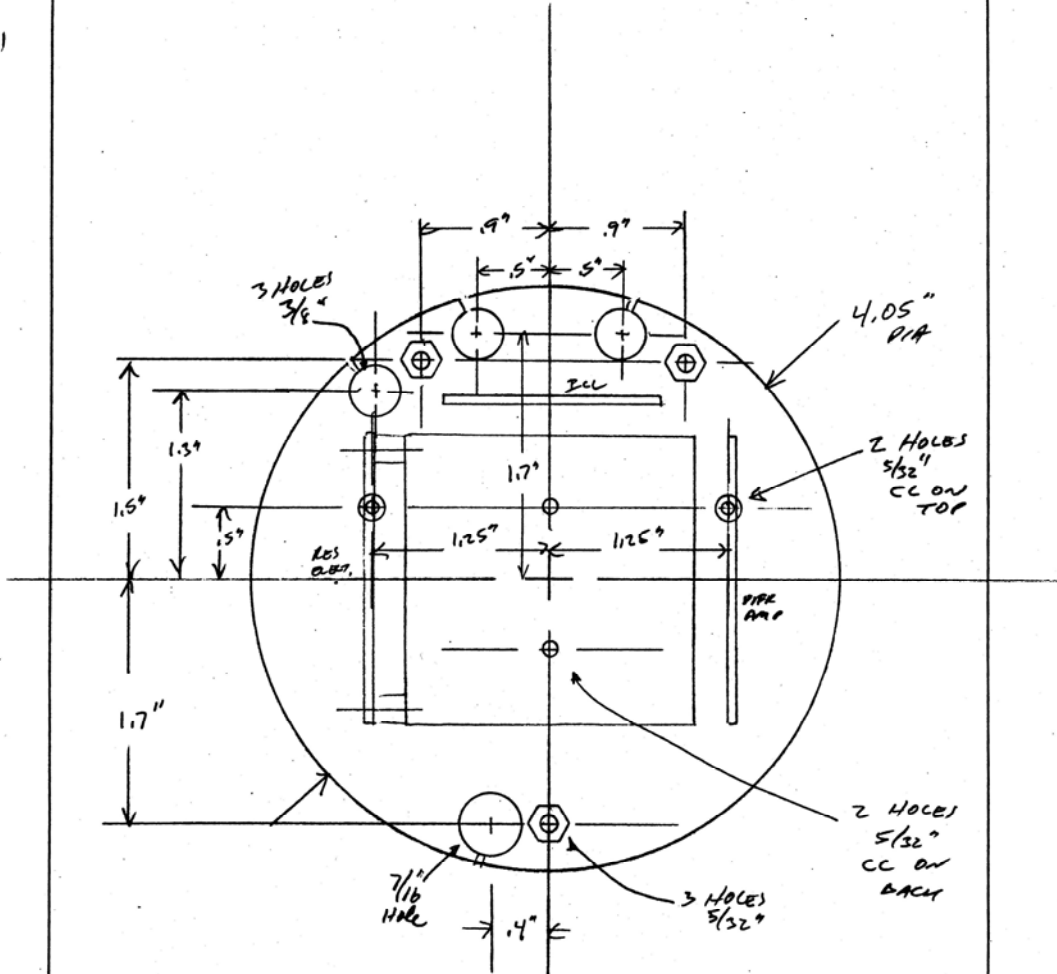

MATERIAL:
1/4" PVC
SCALE:
PULL STRIP
QUANTITY:
1 EA

Rue Johnson
6/30/04

TTS RES LOGGER
#3 PLATE

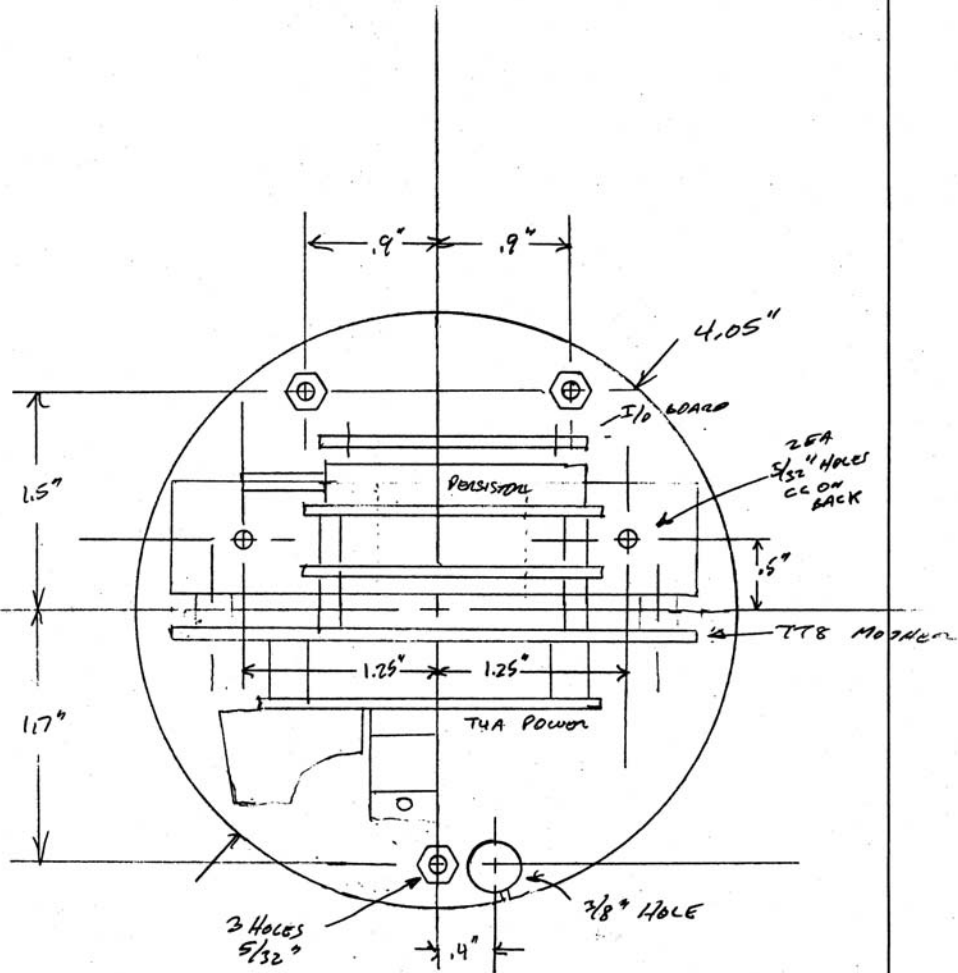

MATERIAL:
1/4" PVC
SCALE:
FULL SIZE
QUANTITY:
1 CA

NOTES:
MOUNT I/O BOARD ON 1/16" NYLON WASHERS.
MOUNT TTS MOTHER BOARD ON 3/16" STANDOFFS.

Ray Johnson
6/20/04

TTB RES LOGGER
#4 PLATE
CANADIAN VERSION

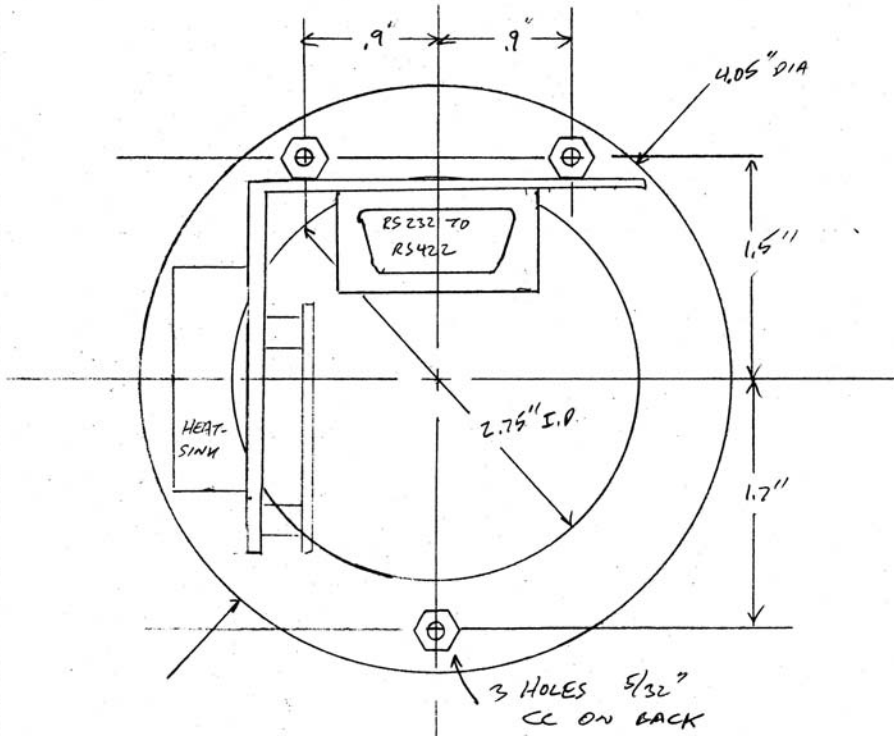

MATERIAL:
1/4" PVC
SCALE:
FULL SIZE
QUANTITY:
1 EACH

Art Johnson
3/26/2010

TTS RES LOSSEL
REG + CONVERTER
MOUNT

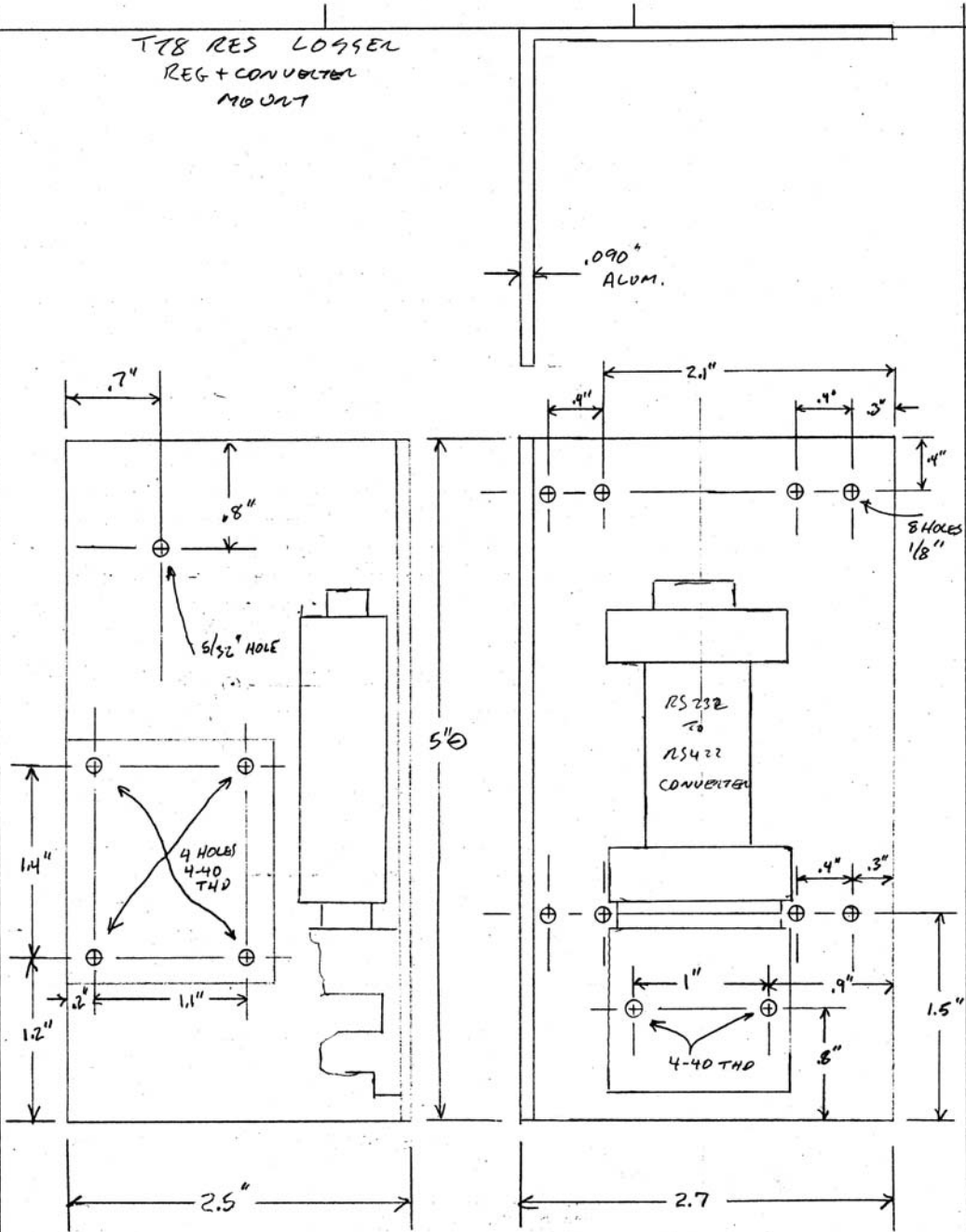

Rex Palmer
3/30/2010

T78 RES LOGGER
T78 MOUNTS

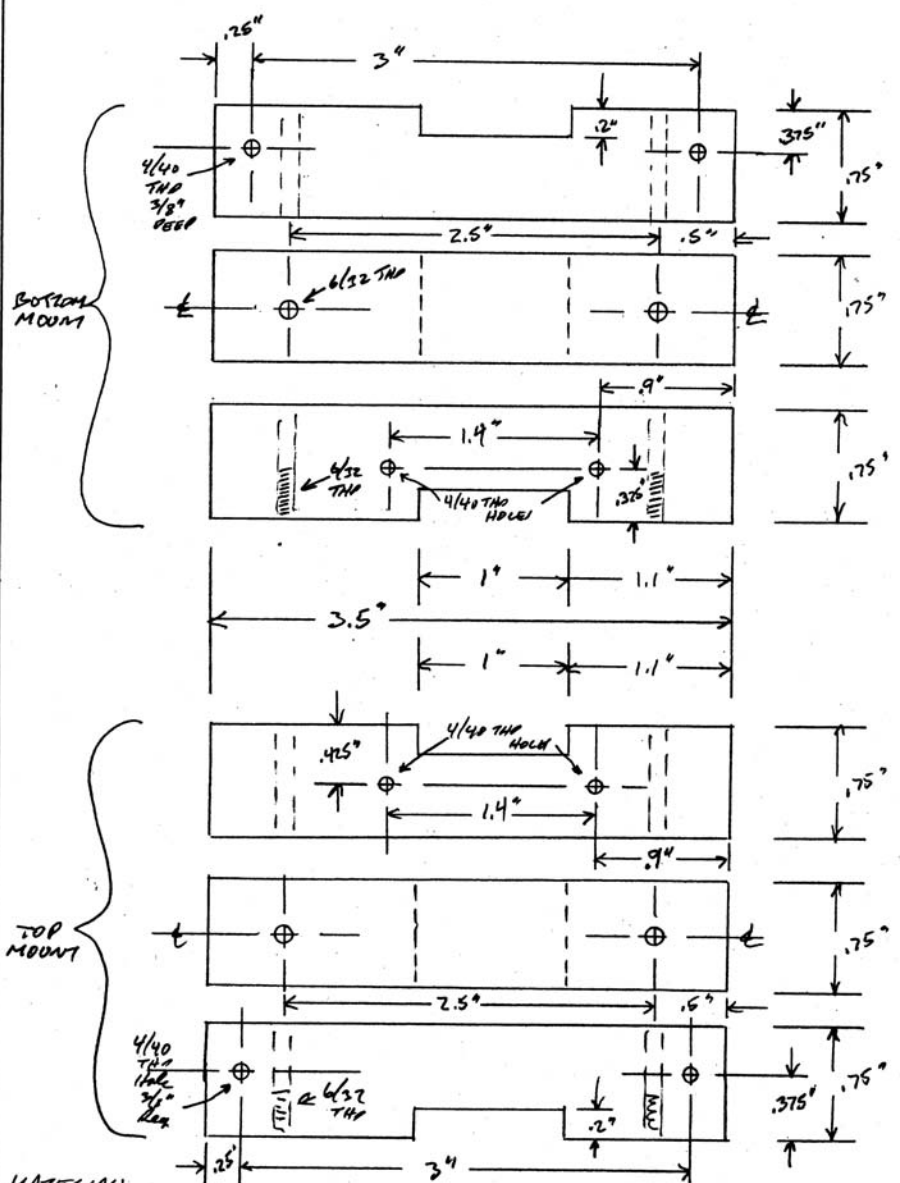

MATERIAL:
BLK DELRIN 3/4 x 3/4"
MCMASTER # 8663421
SCALE:
FULL SIZE
QUANTITY:
1 EA

Ray Palmer
6/30/04

TT8 RES LOGGER
ELECTRONICS MOUNT

NOTES:

MAKE 2 PIECES

- (A) PLATE #2 MOUNT
- (B) PLATE #1 MOUNT

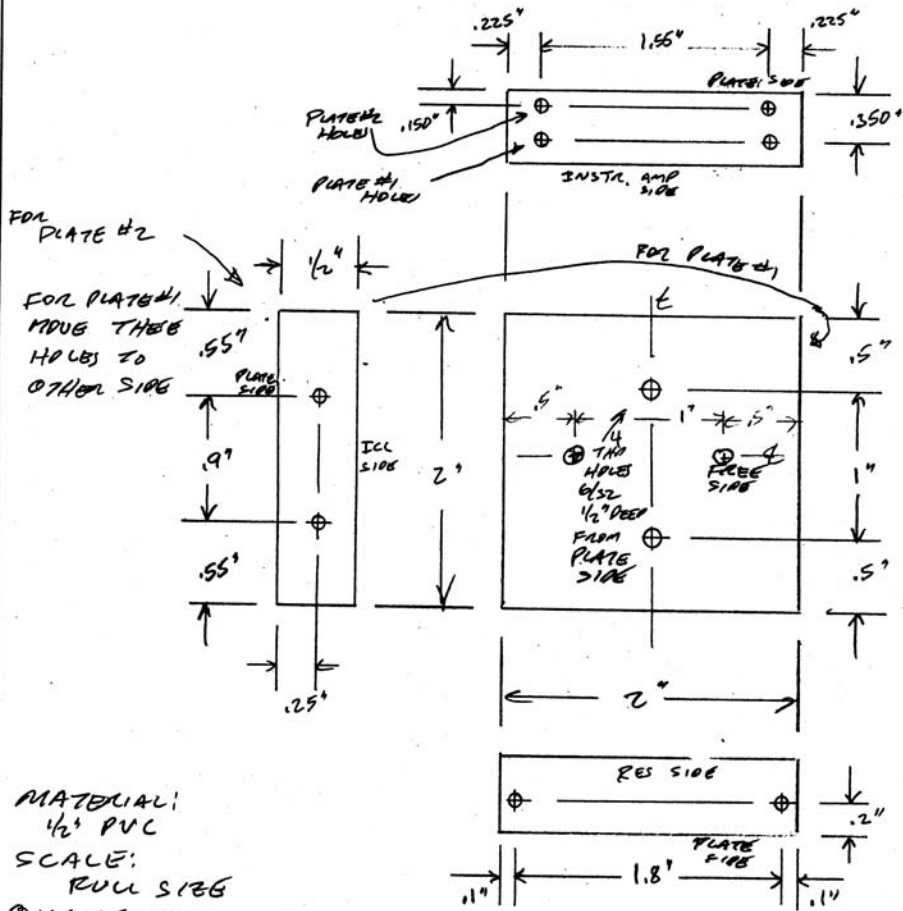

MATERIAL:
1/2" PVC
SCALE:
FULL SIZE
QUANTITY:
2 - TOTAL
1 of EACH

ALL SIDE HOLES:
4-40 x 3/8 DEEP

Rev. 1/1/68

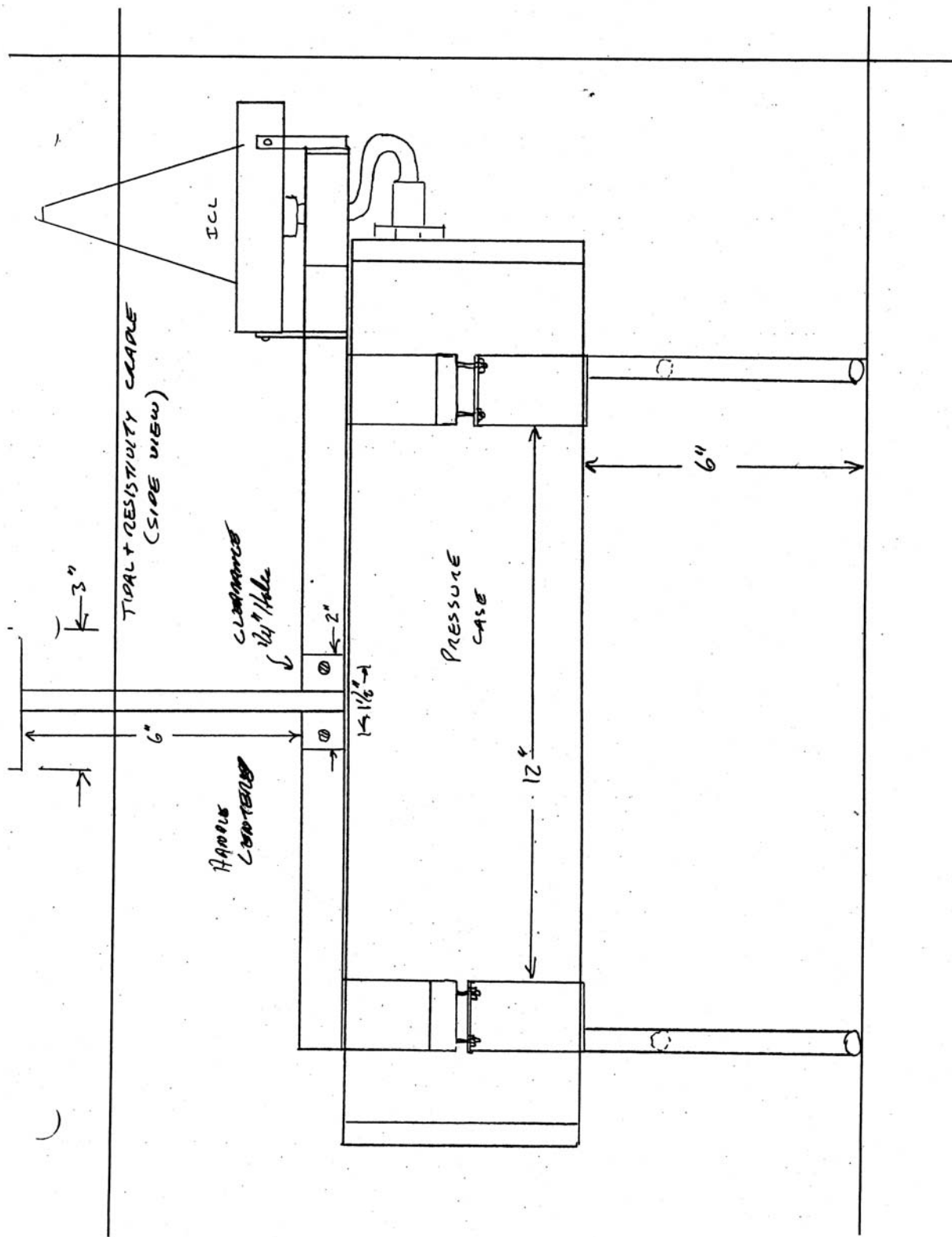

TIDAL + RESISTIVITY CRAPLE
(TOP VIEW)

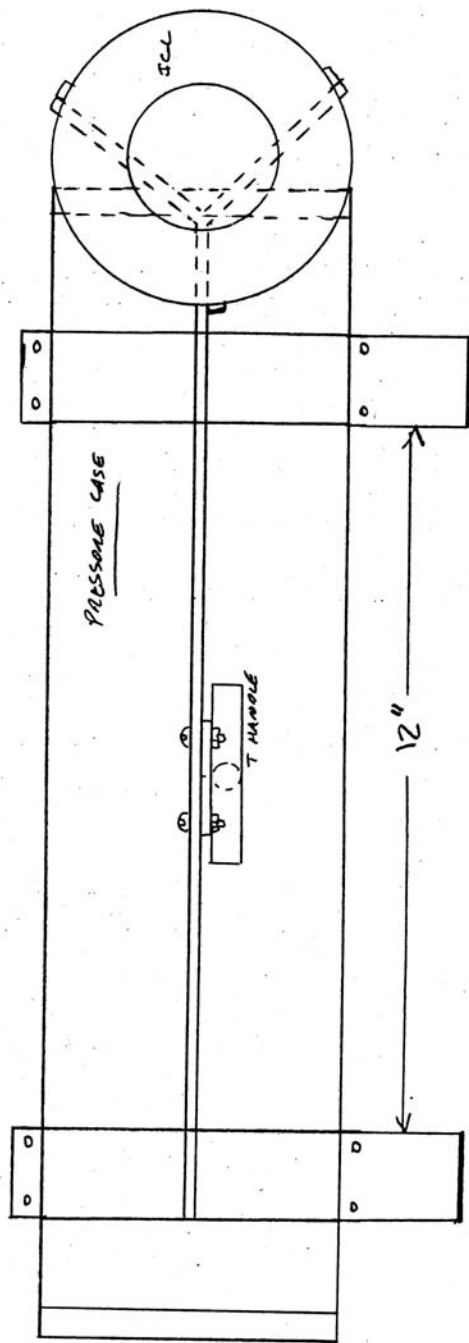

By Johnson
5/4/00

RESISTIVITY X TIGAL LOG-GON CRAPLE
TOP CLAM SHELL

2 EACH
PER UNIT

MATERIAL:
GRADE 2 TITANIUM
1/16"

LENGTH BEHIND
BEARING 10 1/2"

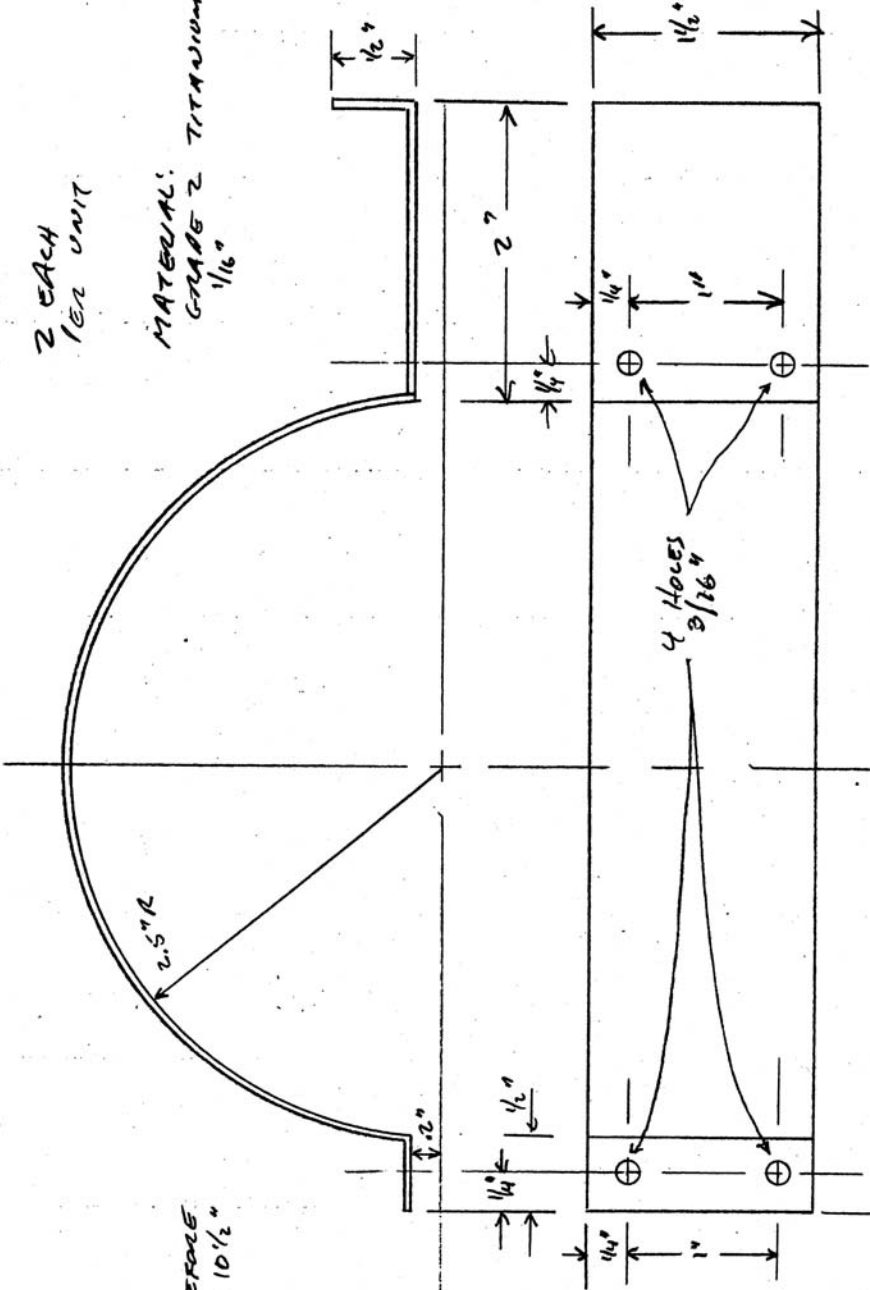

Ray Johnson
10/15/84

RESISTOR + TIDAL LOGGER CRADLE LEGS

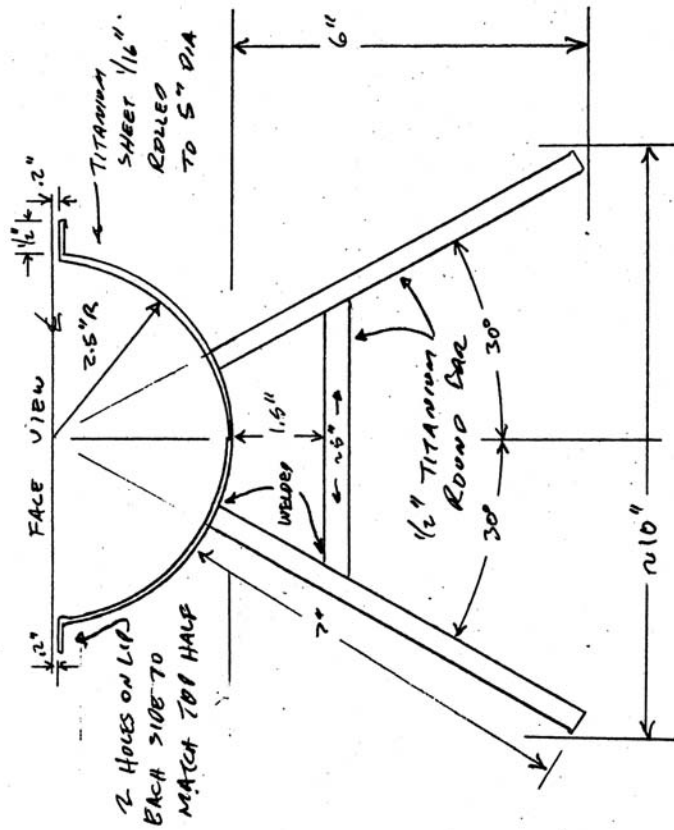

HO/RS/01
10/18/01

Hydrothermal vent resistivity probe: Machined components

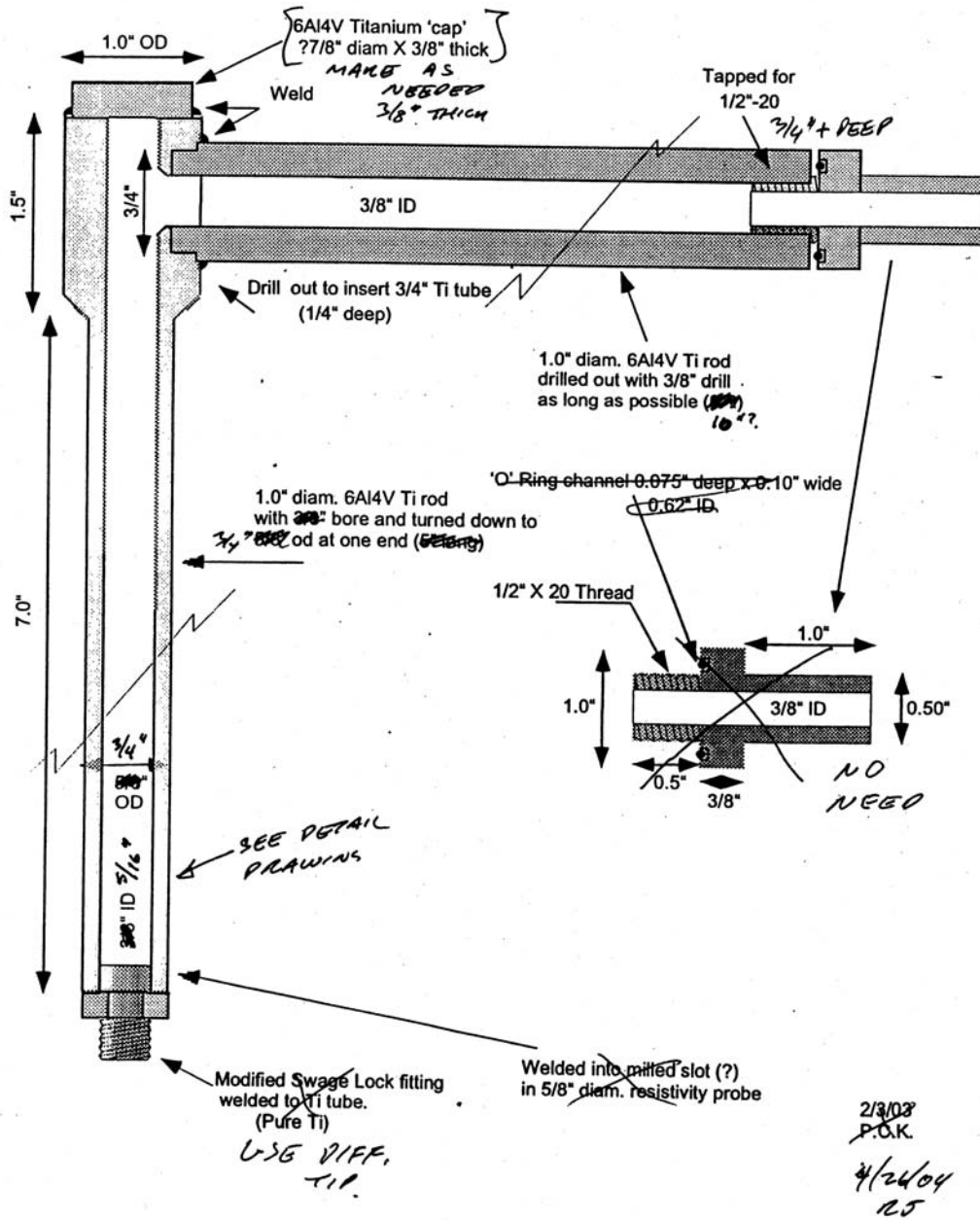

RES PROBE PROTECTOR

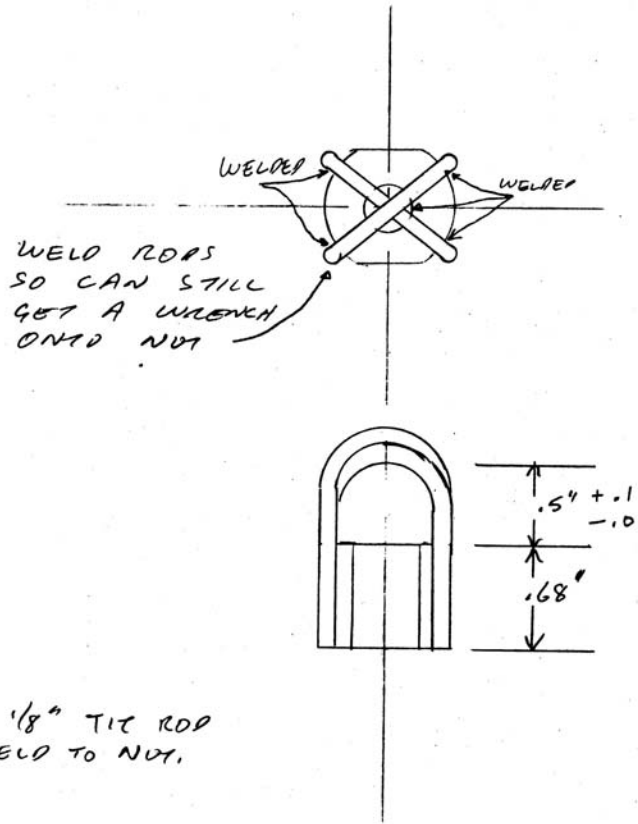

USE 1/8" TIT ROD
+ WELD TO NUT.

Ray Johnson
5/11/05

Hydrogen Sensor End Cap (Connector End)

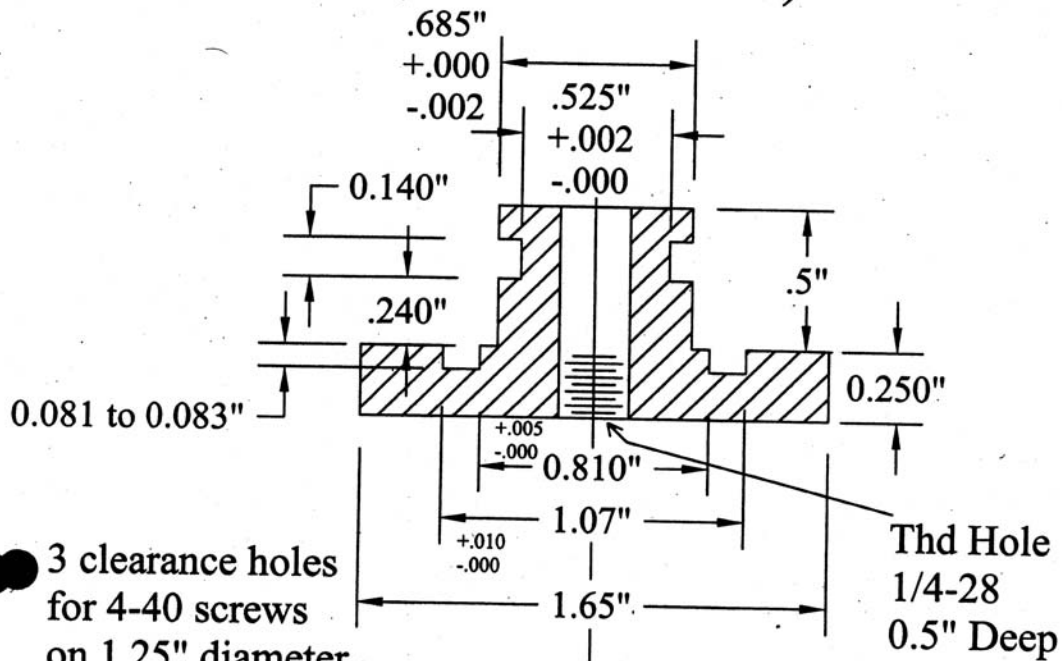

3 clearance holes
 for 4-40 screws
 on 1.25" diameter
 120° Apart to
 match case.

0.65" Dia.

O-rings:
 Piston - 112
 Face - 117

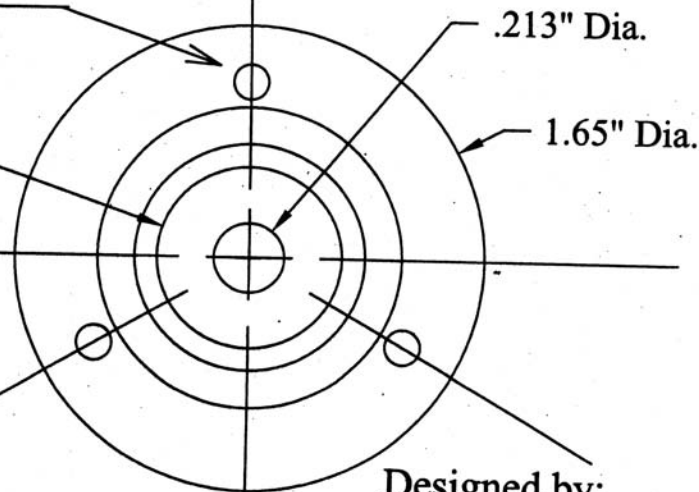

Scale: 2X
 Material: Grade 2 Titanium
 All Dimensions - Inches
 Both ends of case the same.

Designed by:
 Rex Johnson
 Engineering Services
 July 28, 2004

Hydrogen Sensor End Cap

(Sensor End)

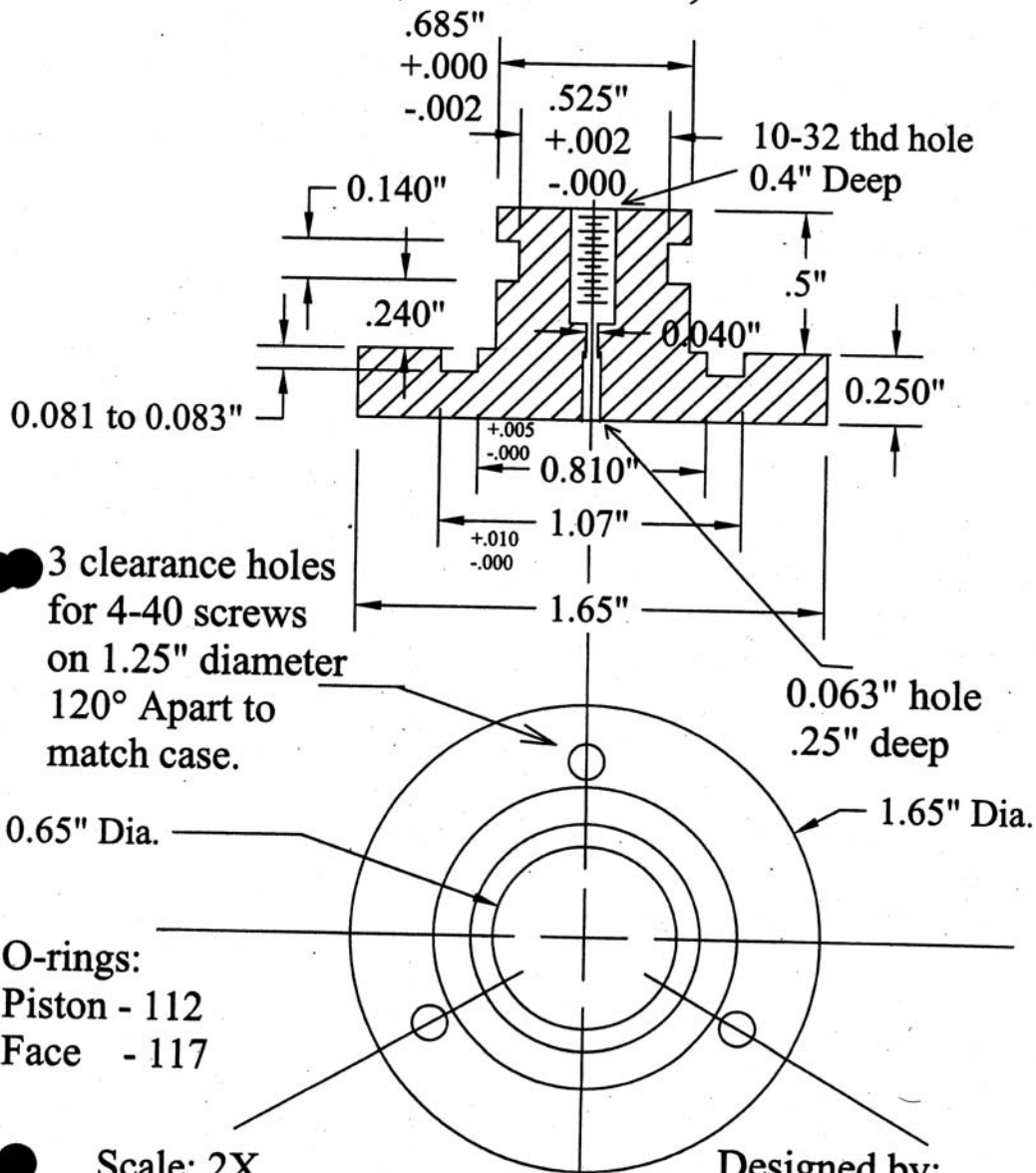

Scale: 2X
 Material: Grade 2 Titanium
 All Dimensions - Inches
 Both ends of case the same.

Designed by:
 Rex Johnson
 Engineering Services
 July 28, 2004

Hydrogen Sensor Case

3 threaded holes
4-40 x 0.6" deep
on 1.25" diameter
120° Apart

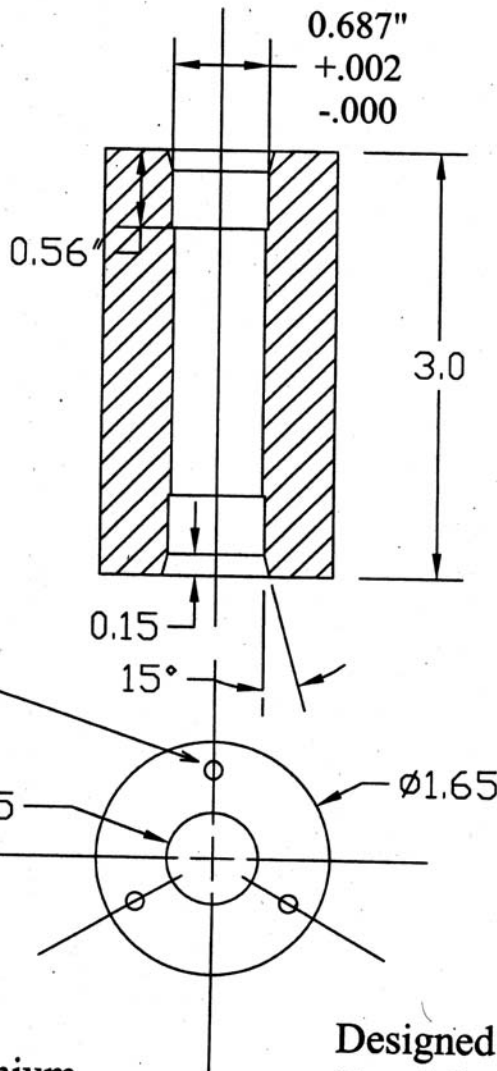

Scale: 1X

Material: Grade 2 Titanium

All Dimensions - Inches

Both ends of case the same.

COLLAPSE 22732 P51 (50604 ET)

Designed by:
Rex Johnson
Engineering Services
March 19, 2004

Merv Lilley High PT Conductivity Pressure Case

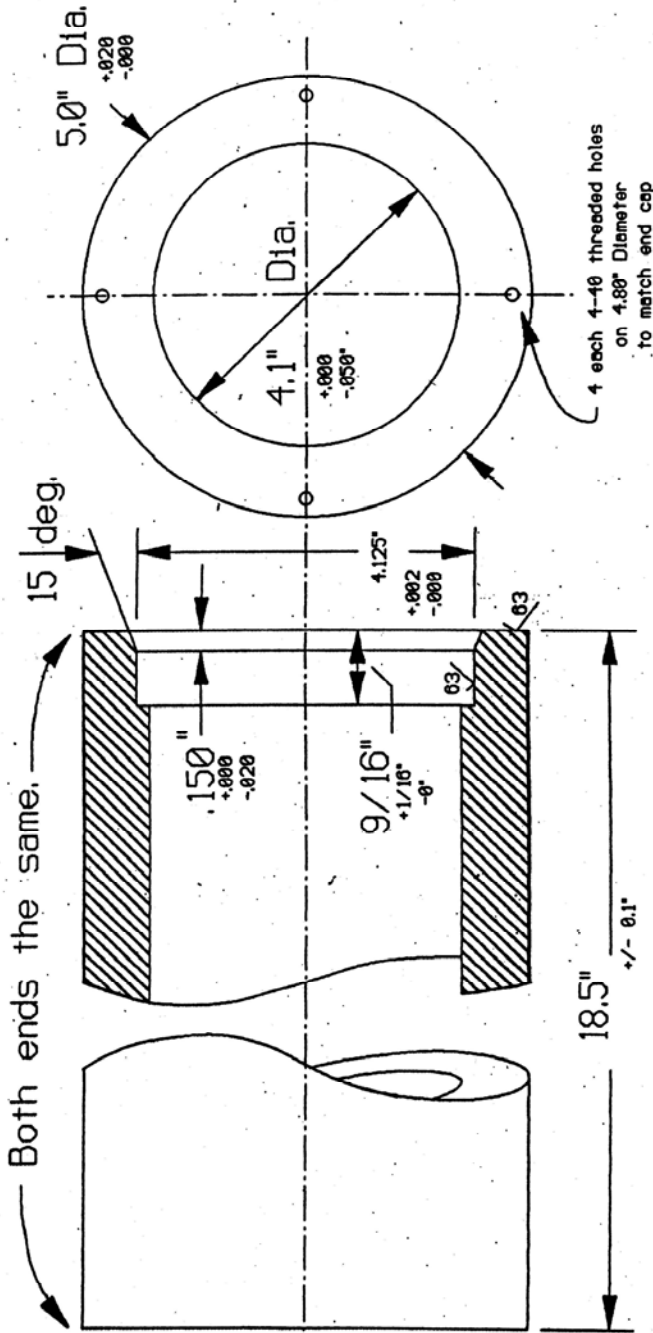

Material: 6AL-4V Titanium
 Break all corners .005" Radius
 Collapse Rating: 19656 PSI (43755 Ft)

Weight in air: 23#
 Weight in water: 7.4#

Drawing Name:
 H-PTC-CS.FCD

Rex Johnson
Engineering Services
April 11, 1995

Marv Lilley High PT Conductivity End Cap

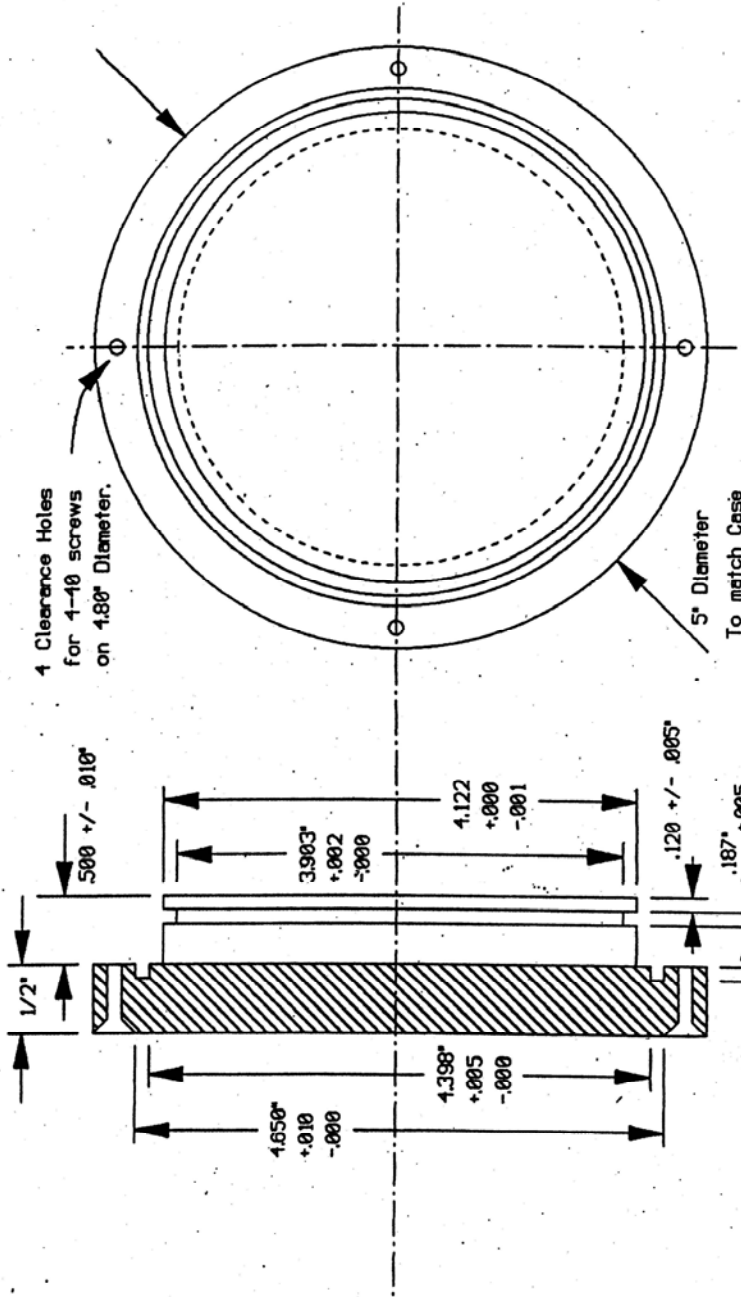

Rex Johnson
 Engineering Services
 April 11, 1995

O-Rings:
 Piston - 241
 Face - 158 (stretched)

Material: 6AL-4V Titanium
 Break all corners .005" R
 All O-ring surfaces 63 finish
 Drawing Name: H-PTC-EC.FCD

RES-8 LOGGER
ENDCAP

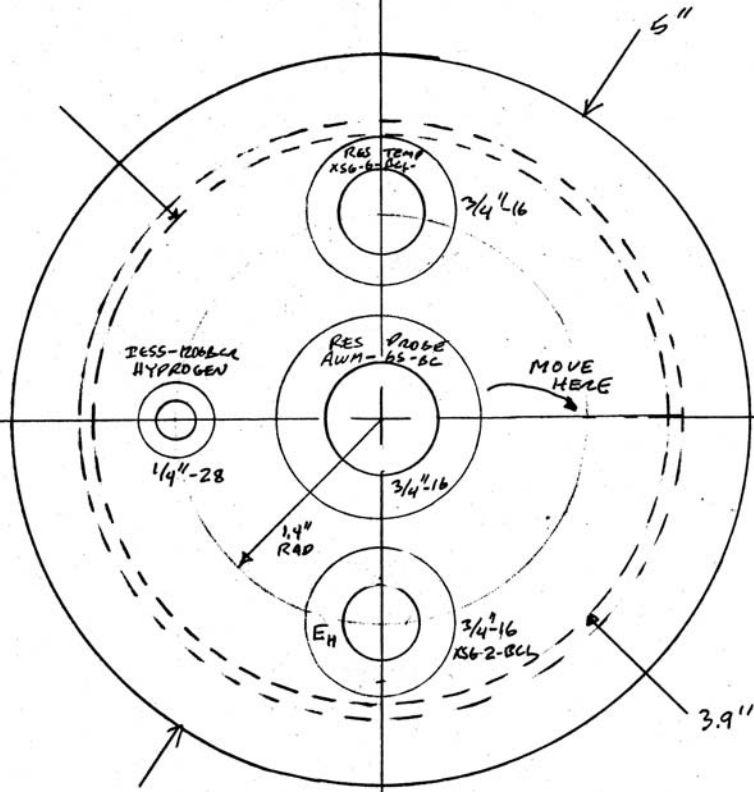

Res Johnson
a/2/04

CANADIAN RES & COMM ENDCAP
DETAILS

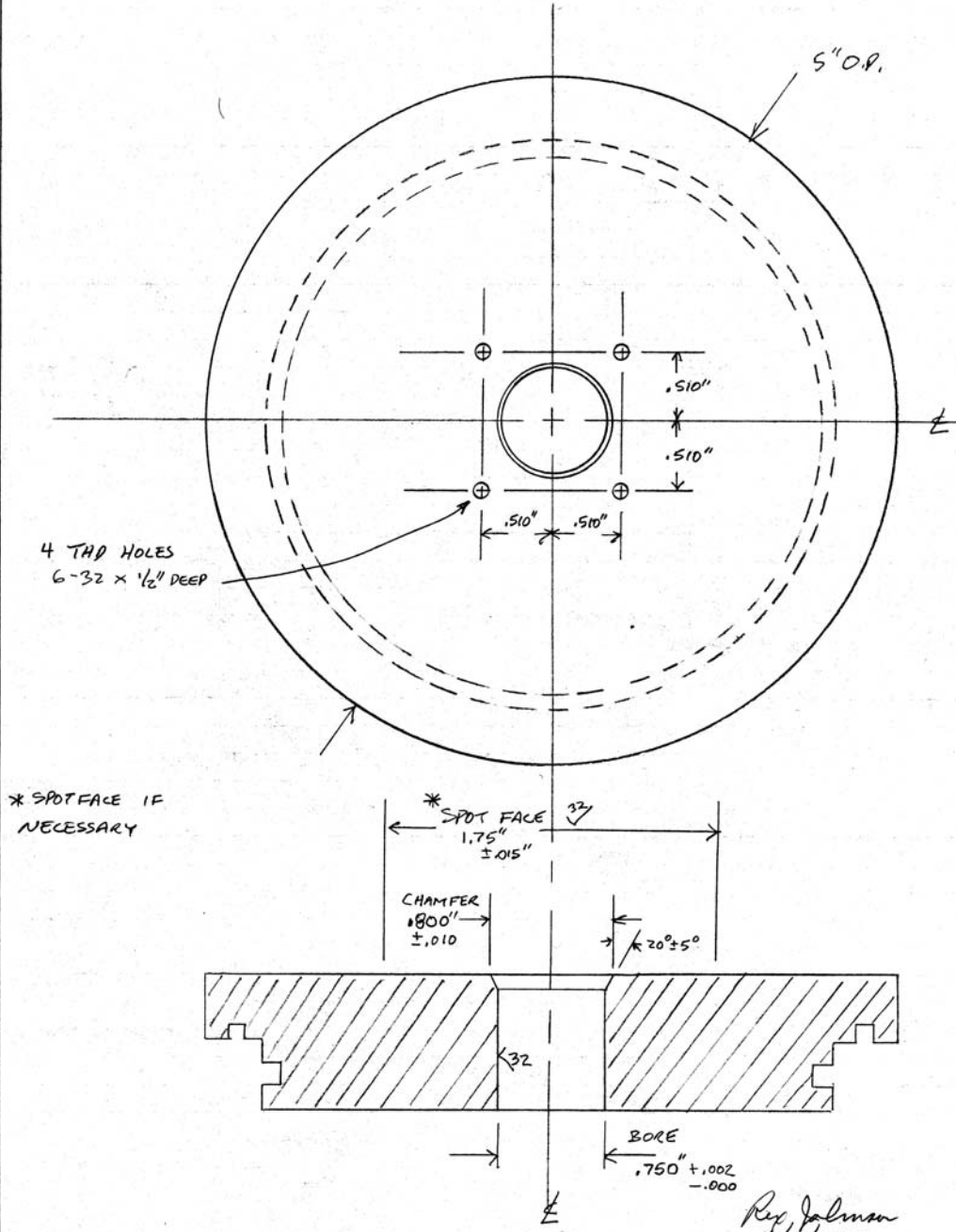

Section 5

System Notes



RS232 to RS422 converter
Model RS422D9

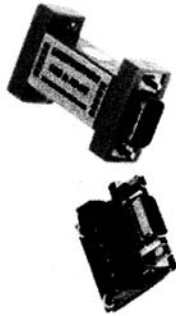

This bi-directional RS232 to RS422 converter is port-powered with an optional external power supply terminal. An internal amplifier supplies power from the RS232 port without initializing the RS232 interface. If the RS232 port is not capable of supplying enough power, an external power supply can easily be connected to the converter. It supports 4-wire RS422 communications, which allows two peer participants to operate in full-duplex. The transmission rate of 300 - 115200bps can be applied to point-to-point and point-to-multipoint networks. A simple and reliable solution for most general and industrial communication needs. Header terminal board is included with each unit.

Overall features

- Port-powered, no external power supply required
- Plug and play, no drivers needed
- Static and surge protected
- Optional external power supply
- Handshake control not required, no flow control needed
- CE, FCC, RoHS ISO 9001 Certified
- Terminal board included with each unit

SPECIFICATIONS	
Model number	RS422D9
Baud rate	300 - 115200bps
Power	Port-powered from RS232 (RTS, DTR, TXD) Optional external power: 5 - 12VDC < 10mA
Current consumption	< 10mA
Interface RS232	DB9 female connector
Interface RS422	DB9 male connector and terminal board
Working mode	4-wire RS422 asynchronous, full-duplex differential
Standards	EIA/TIA RS-232C / RS422
Transmission distance RS232	Typical: 15 FT (5m)
Transmission distance RS422	Typical: 4000 FT. (1200m)
Static protection	1500W
Surge protection	600W/ms
Operating Temp.	-40°F to 180°F (-40°C to 85°C)
Operating humidity	5% To 95% - No Condensation
Dimensions	2.47" x 1.33" x 0.70" (62.8 mm x 33.8 mm x 17.8 mm)
Warranty	5-year Limited Warranty

