

STAGES QIEMEM — Advanced Segments Mode — Segments IN GROUPS

...to toggle ignoring rising gates during decay stage

...to toggle slider's polarity

loop for sustain

...to toggle slider's polarity

loop for hold

...to toggle value polarity

SHAPE (rise/fall)

...and wiggle

...and slide

hold

TIME

8V

4V

0V

13m to 16s

16s to 1ms

2.2s to 1ms

TIME MOD -8V to +8V

START (1st)

ENVELOPE (1st) or SEGMENT (n)

SLEW

...and wiggle

...and slide

hold

OFFSET

2V 8V

1V 4V

0V 0V

0V 0V

-2V -8V

penta tonic

major

chro matic

no quant

OFFSET MOD -8V to +8V

START (1st)

ENVELOPE (1st) or SEGMENT (n)

TIME

loop for sustain

...and wiggle

hold

OFFSET

2V 8V

1V 4V

0V 0V

0V 0V

-2V -8V

.25s

.5s

2s

.1s

8s

16s

0s

penta tonic

major

chro matic

no quant

OFFSET MOD -8V to +8V

START (1st)

ENVELOPE (1st) or SEGMENT (n)

STEPS

...and wiggle

hold

BIT FLIP CHANCE

flip

rand

lock

6

8

10

4

12

16

1

FLIP CHANCE MOD -8V to +8V

GATE/TRIG rotates register

VALUE 0V to 8V -5V to +5V

RAMP

STEP

HOLD

STEP ASR



STAGES QIEMEM — Advanced Segments Mode — STANDALONE Segments



...to toggle full-wave rectification

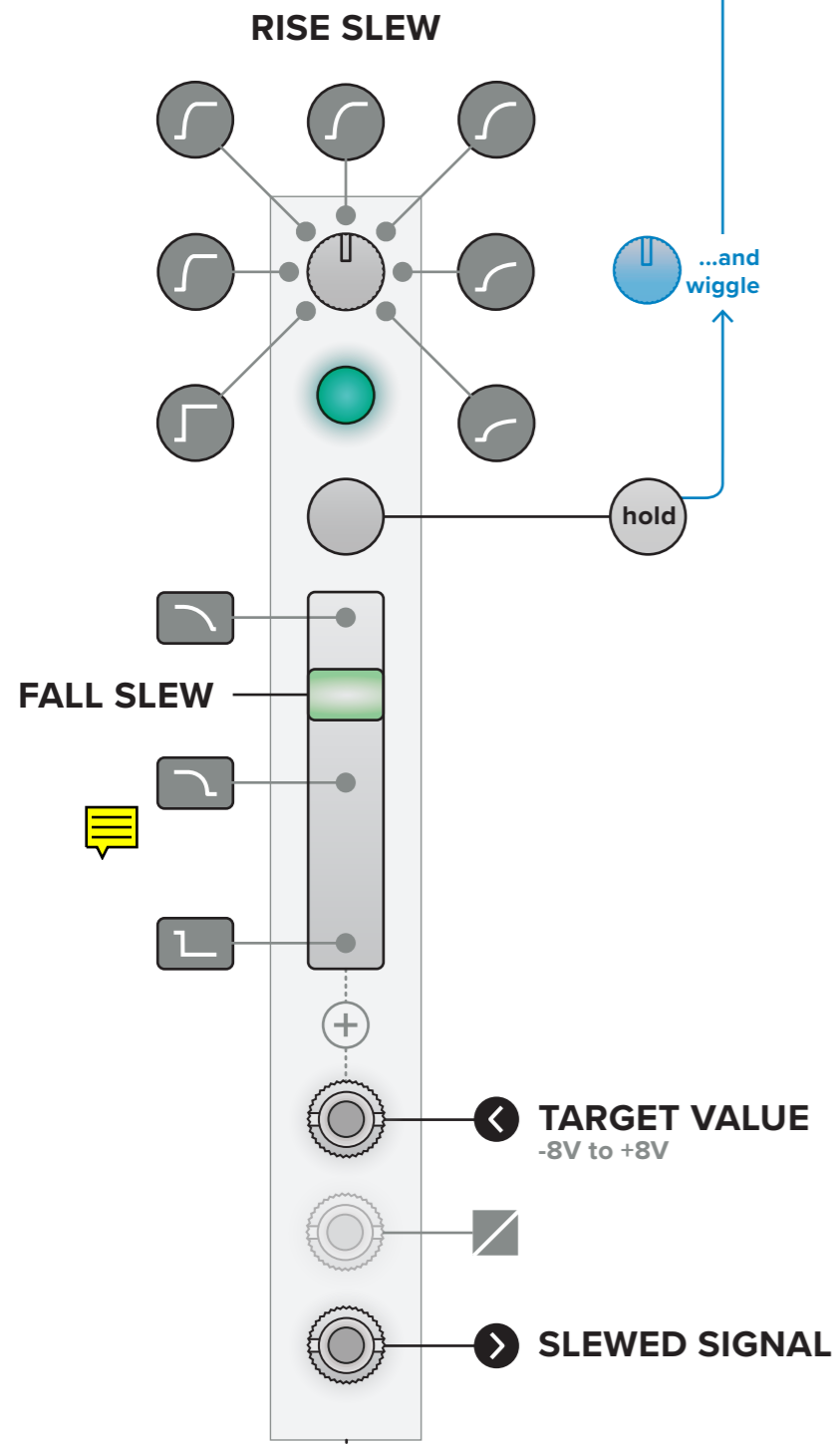

RISE/FALL SLEW

... to toggle LFO signal polarity

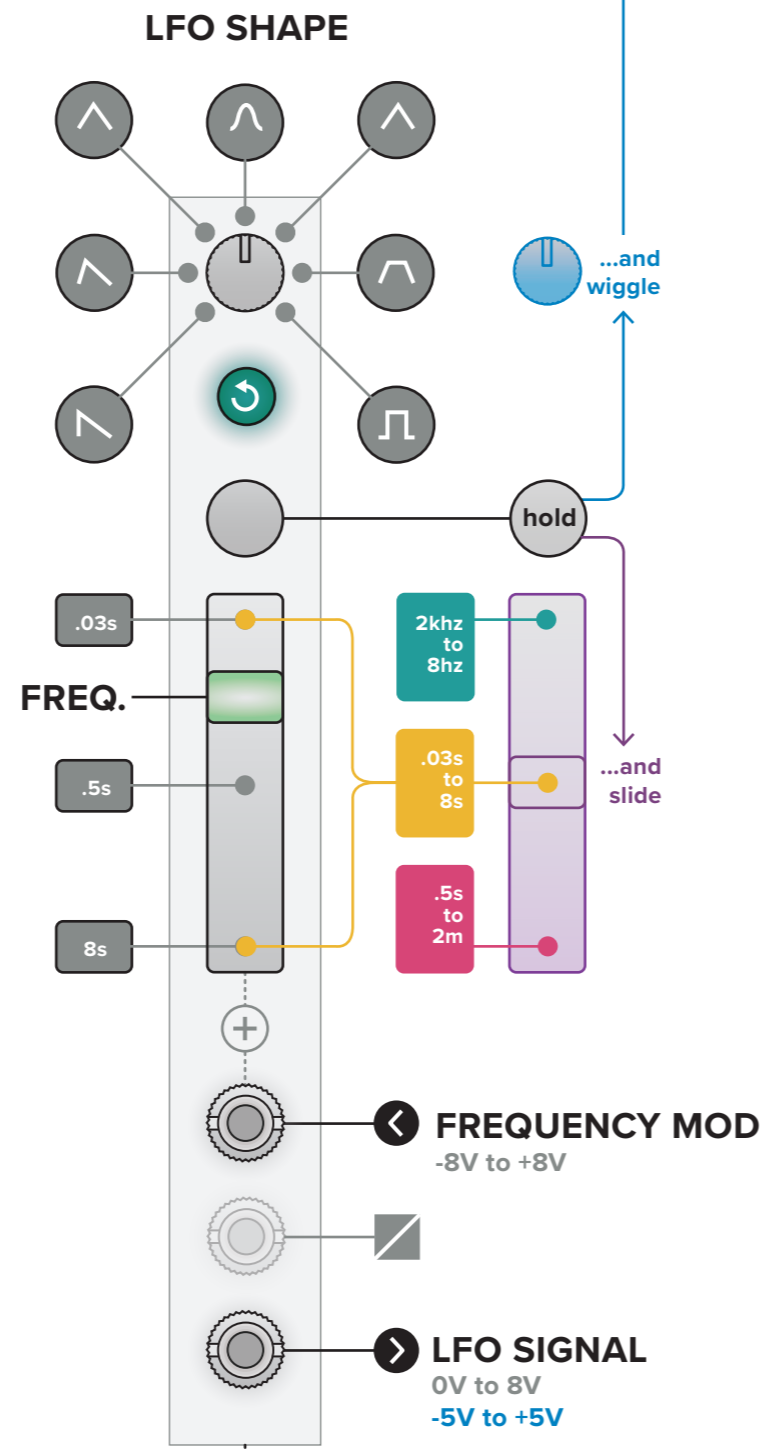

LFO

...to toggle ignoring rising gates during decay stage

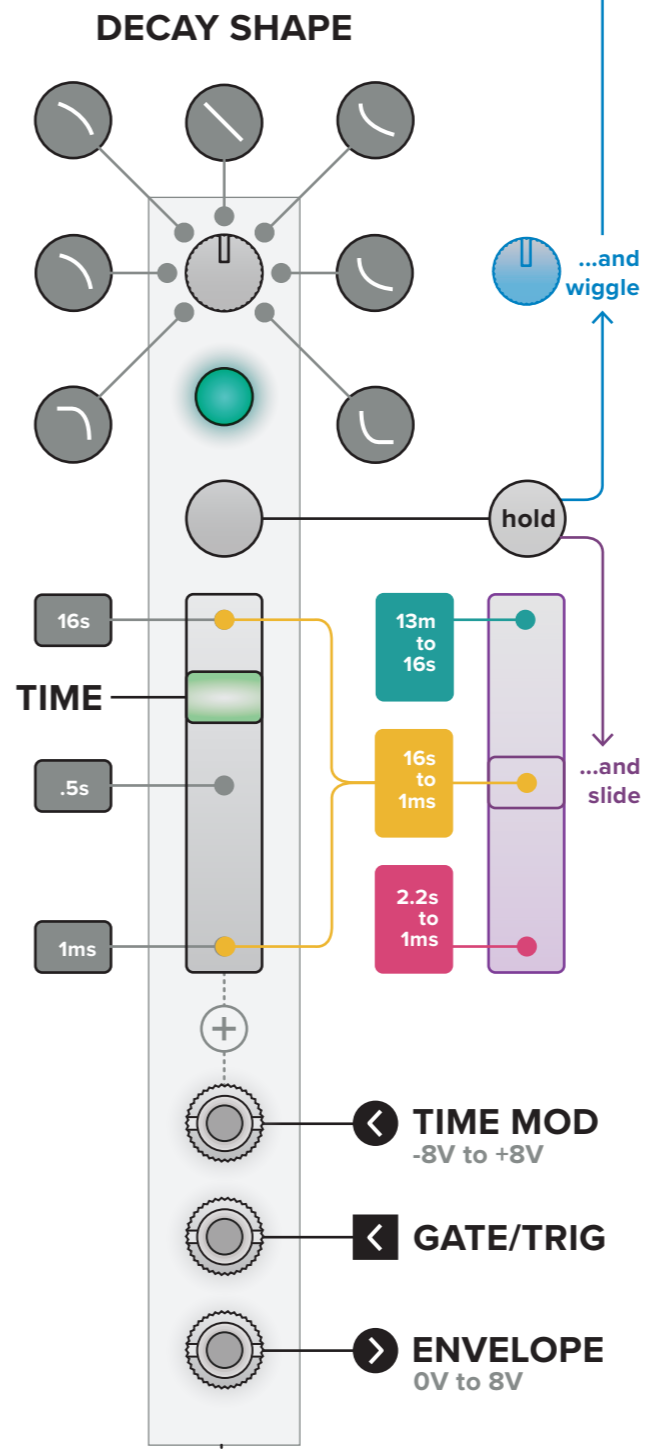

DECAY

...to toggle LFO signal polarity

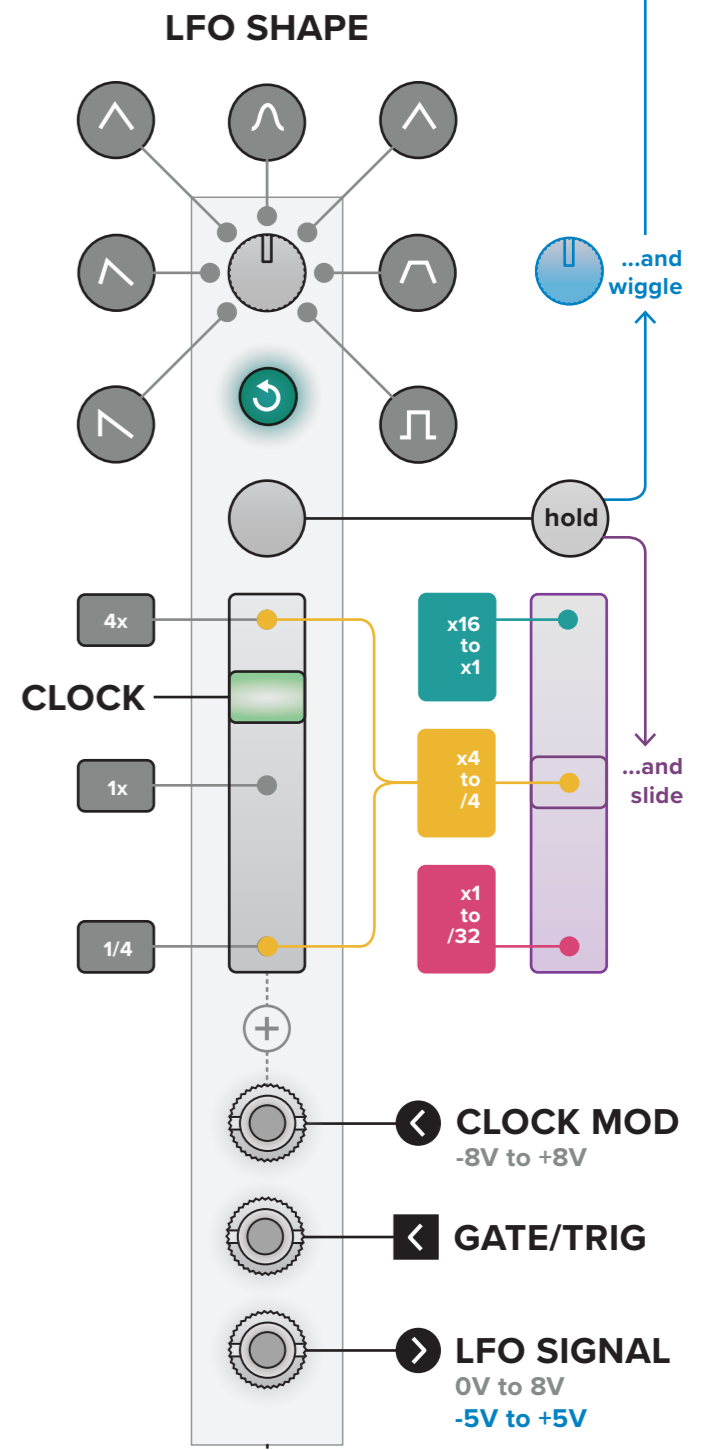

CLOCKED LFO

STAGES QIEMEM — Advanced Segments Mode — STANDALONE Segments

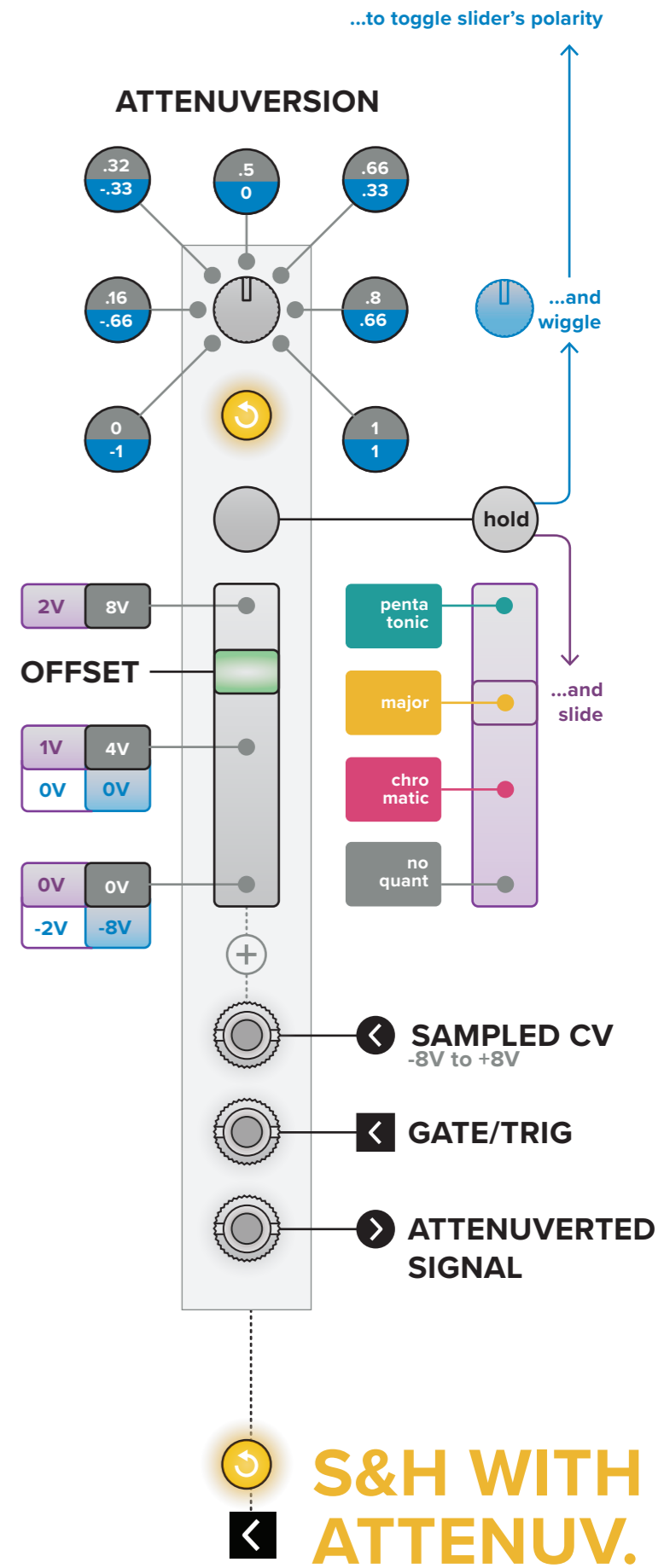
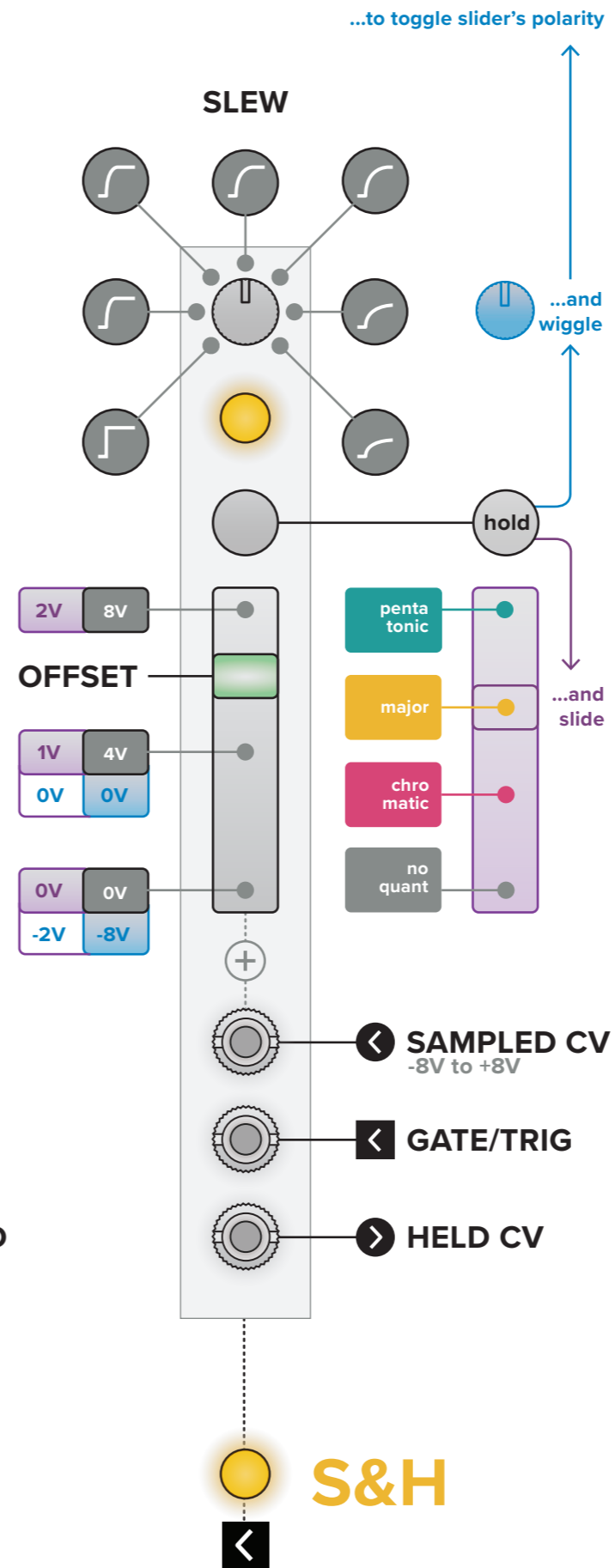
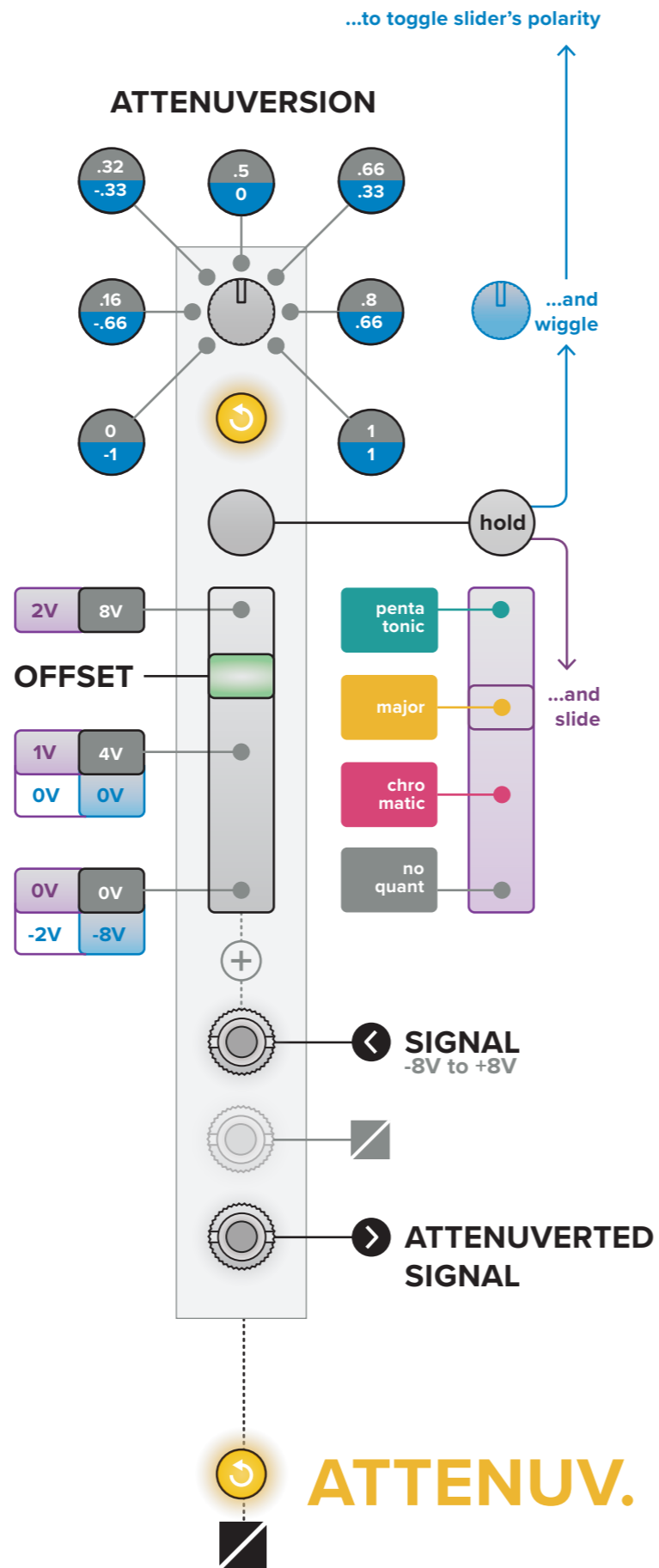
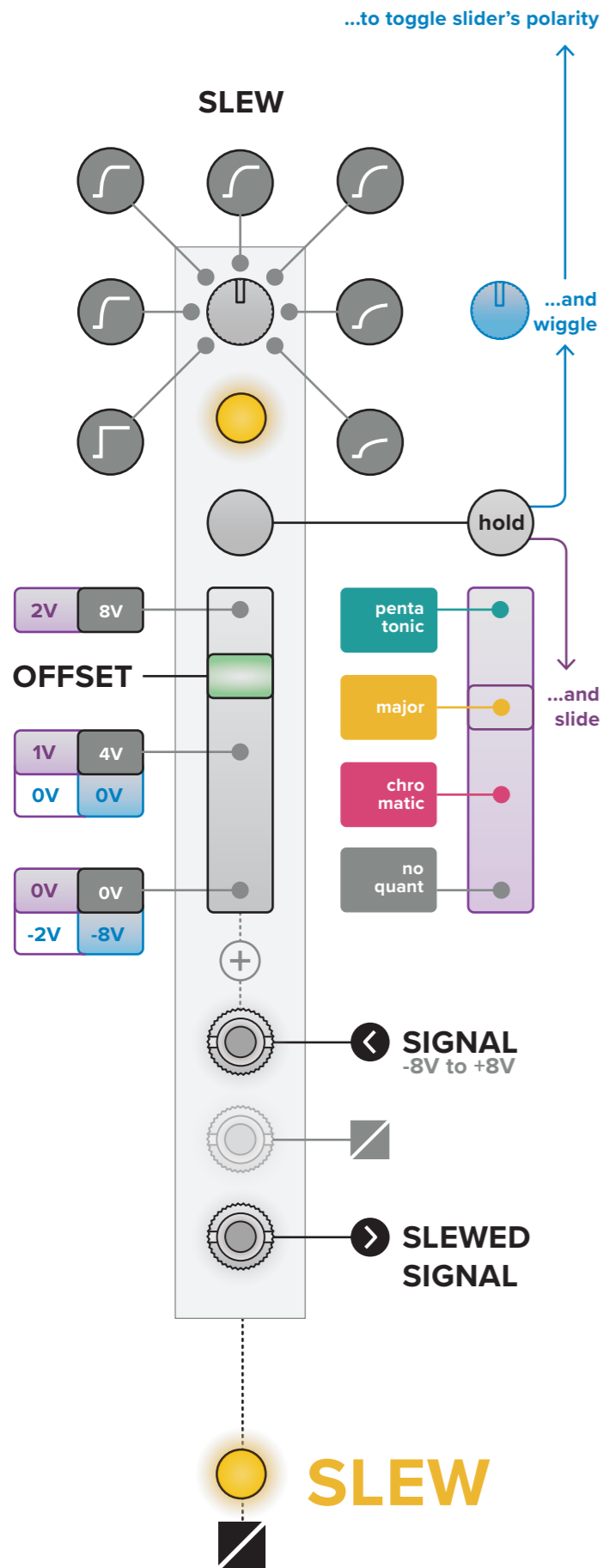

STAGES QIEMEM — Advanced Segments Mode — STANDALONE Segments

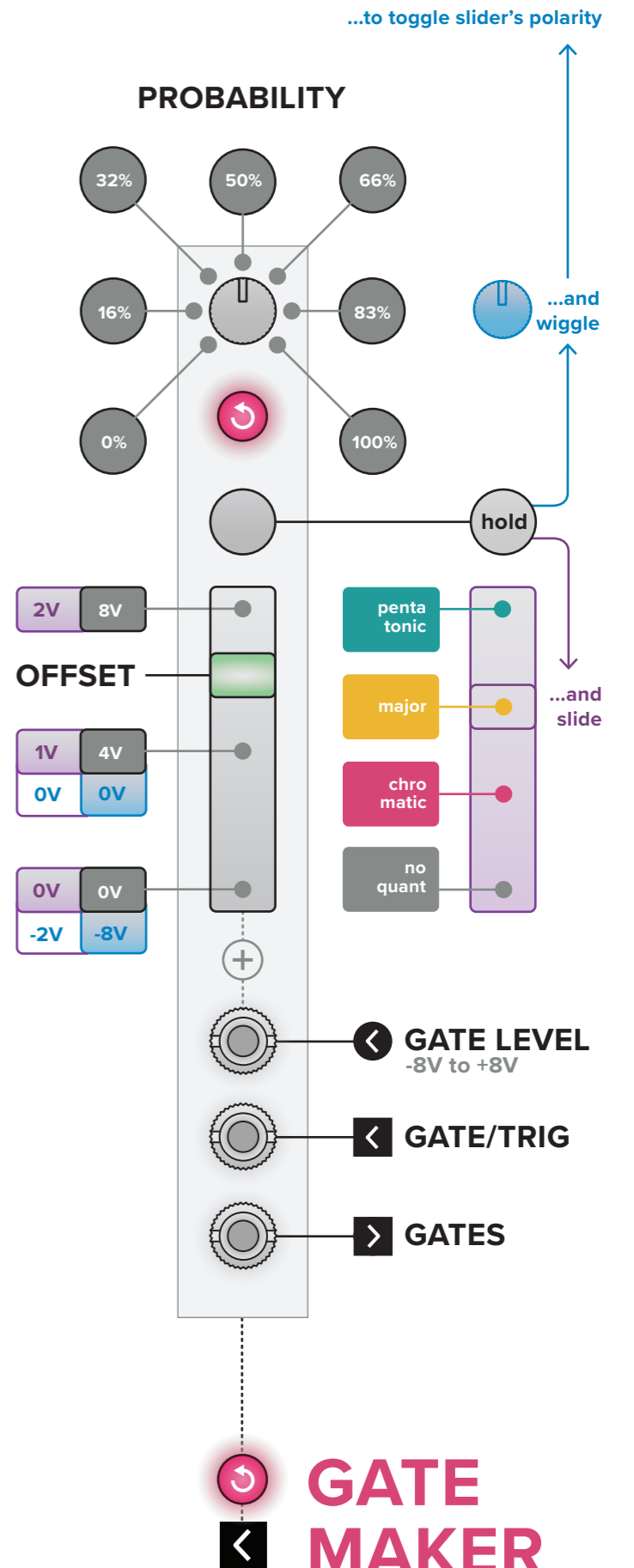
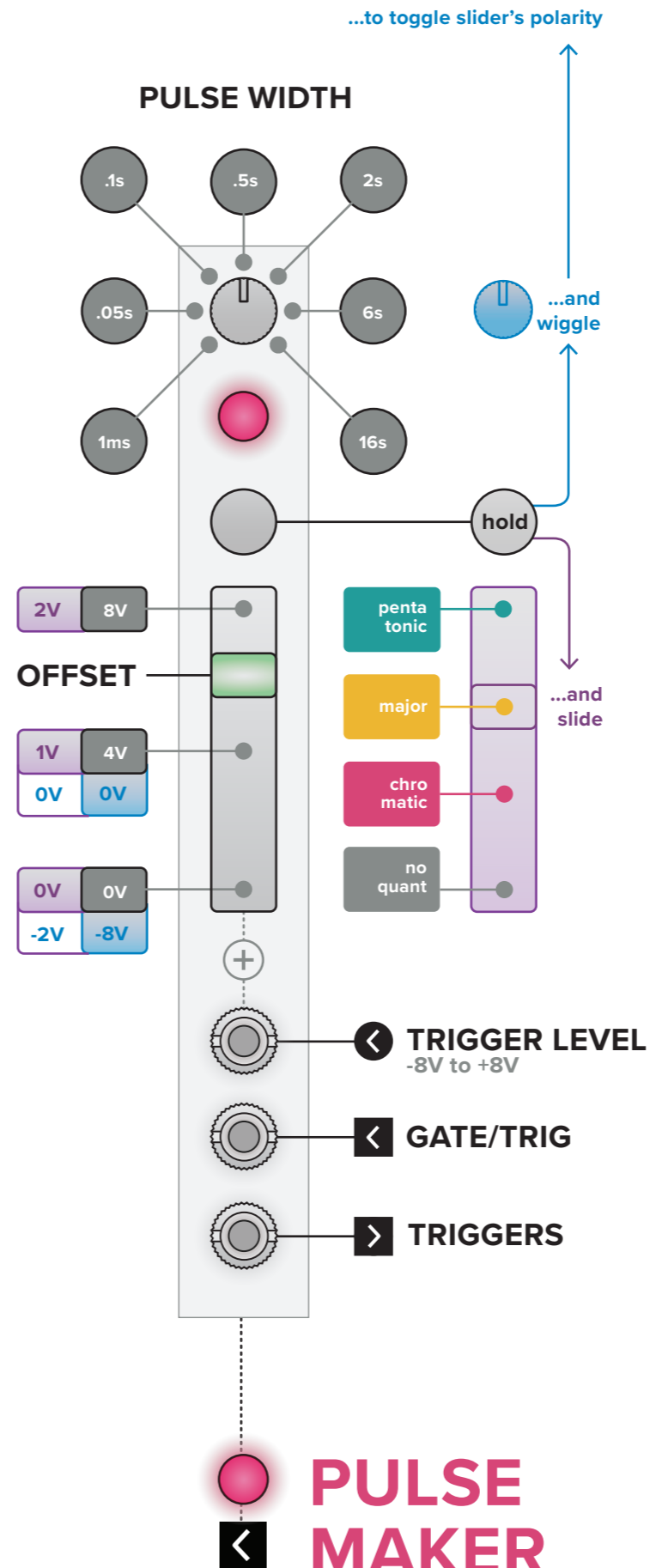
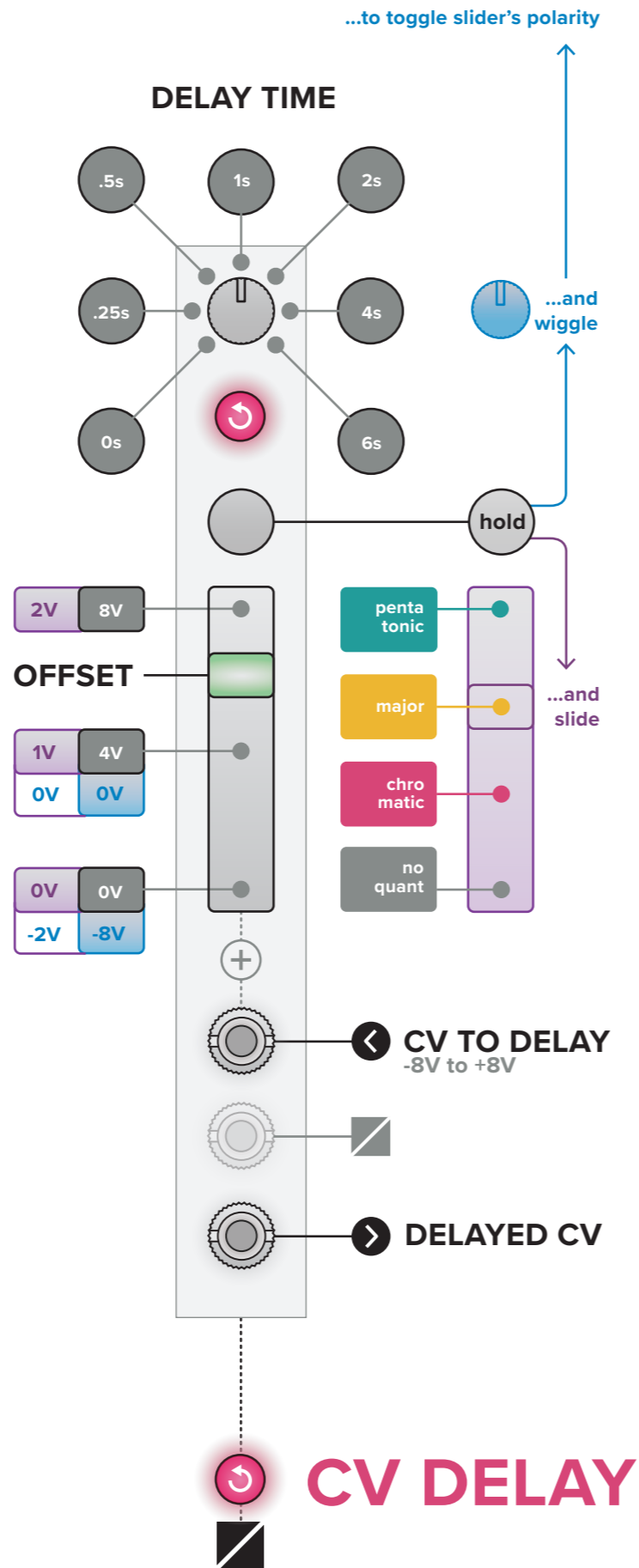
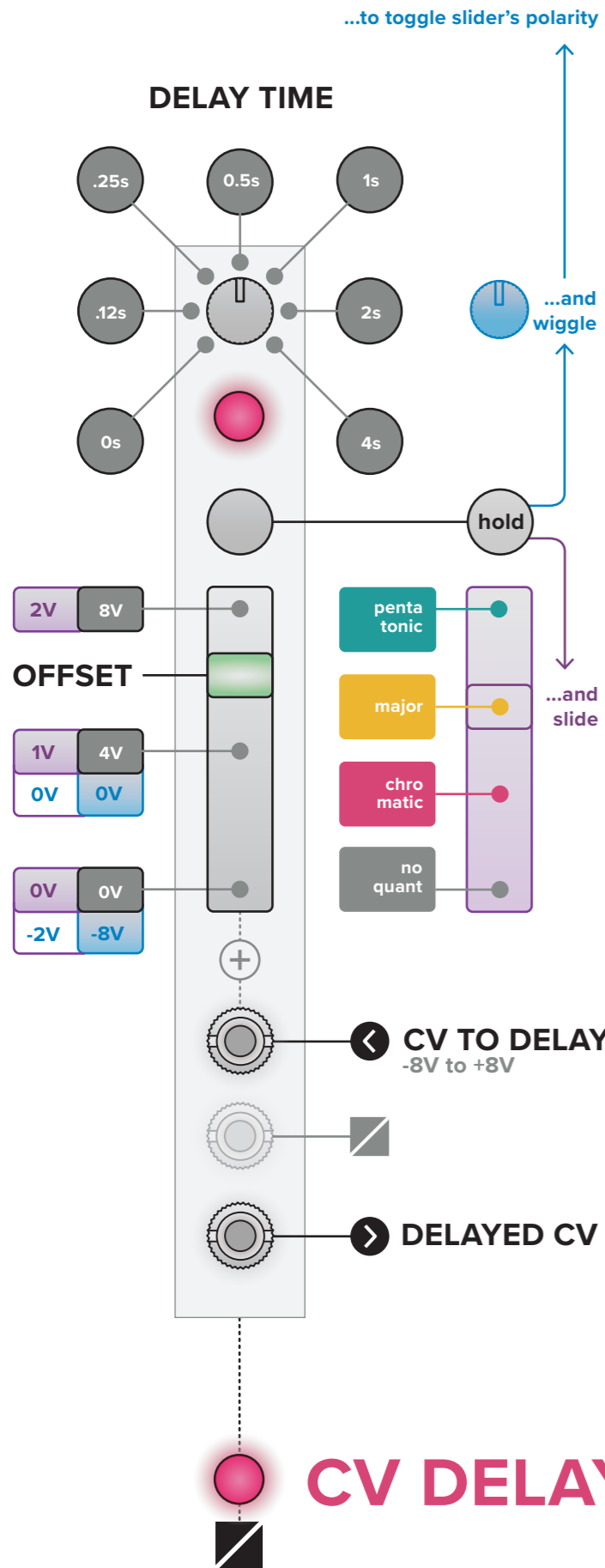

STAGES QIEMEM — Advanced Segments Mode — STANDALONE Segments

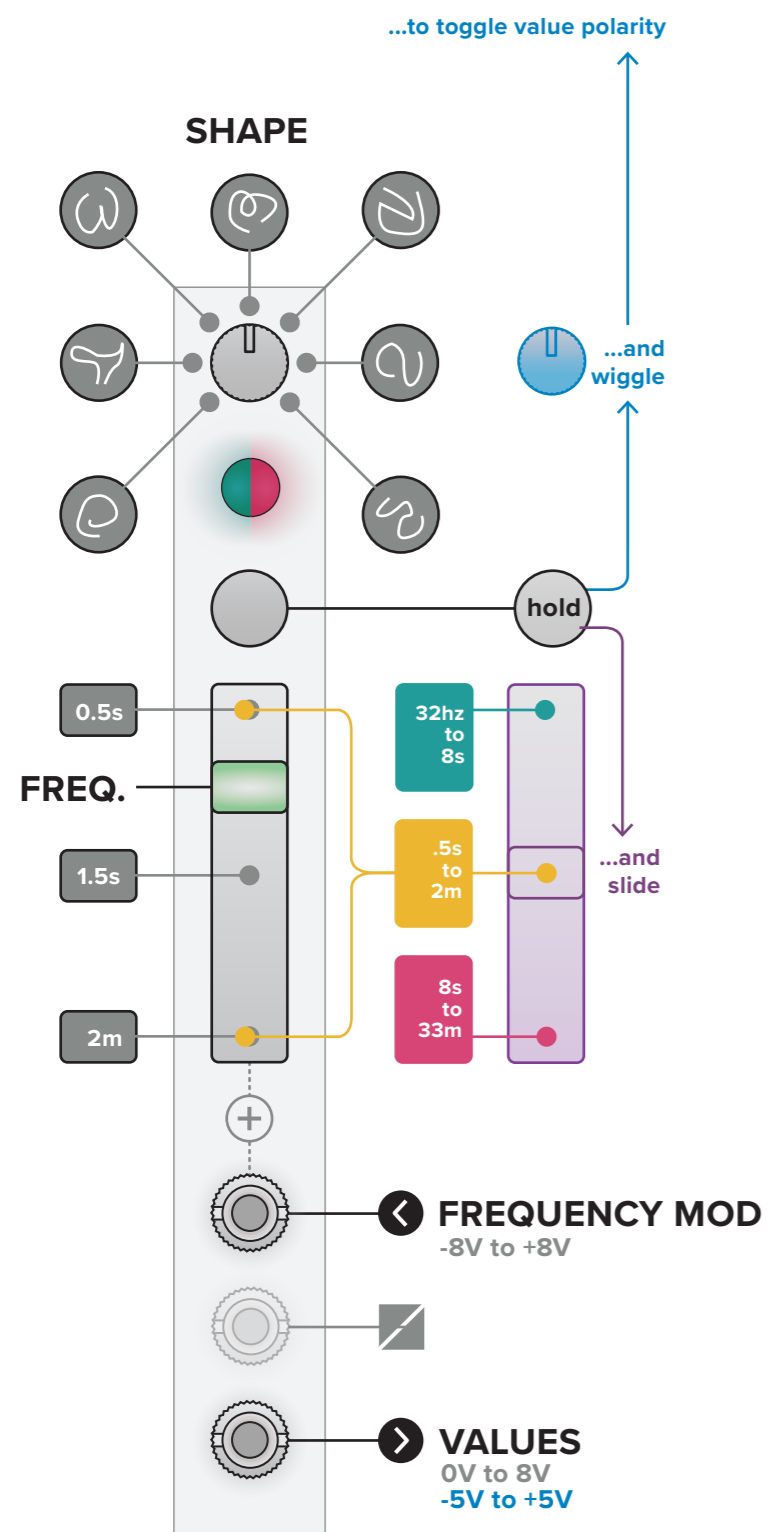

CHAOTIC SMOOTH

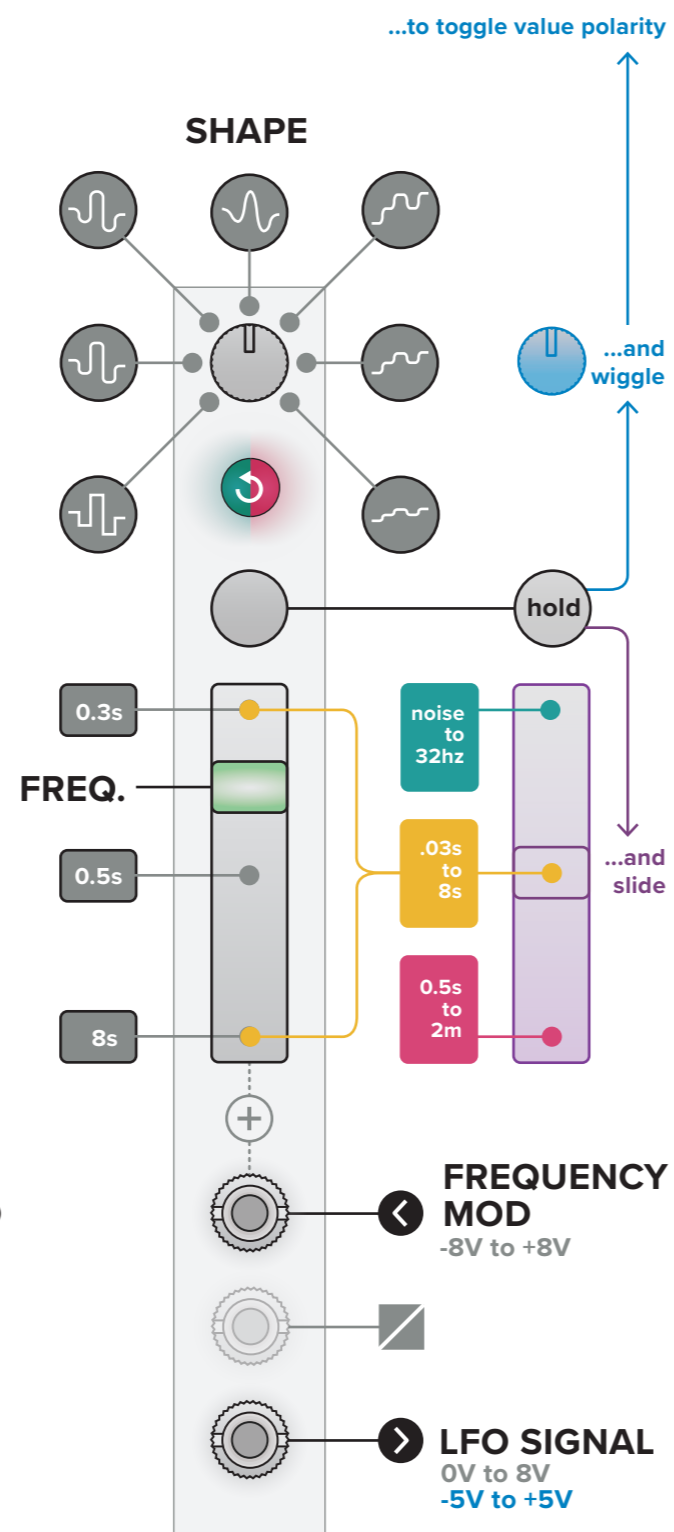

RANDOM LFO

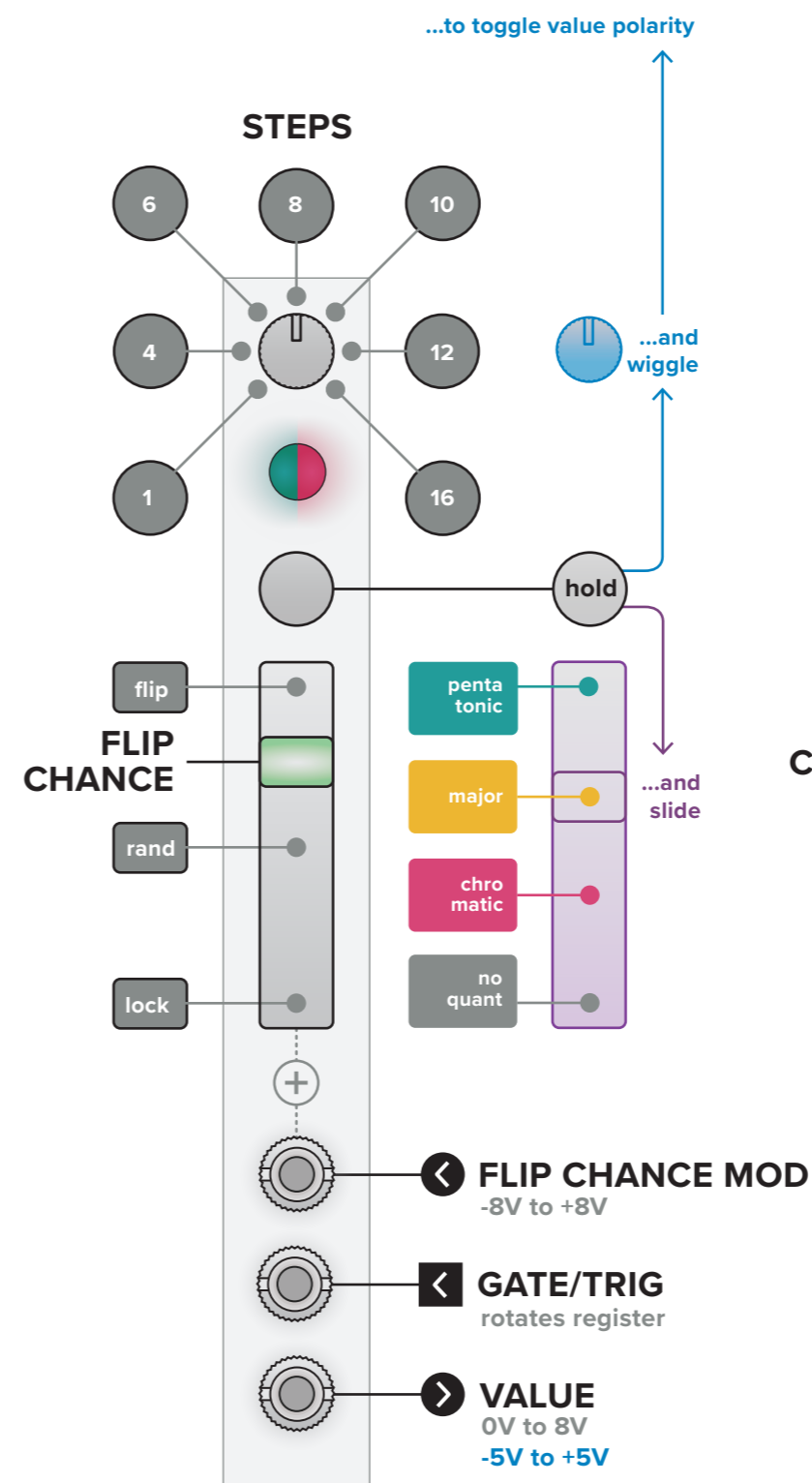

SHIFT REGISTER

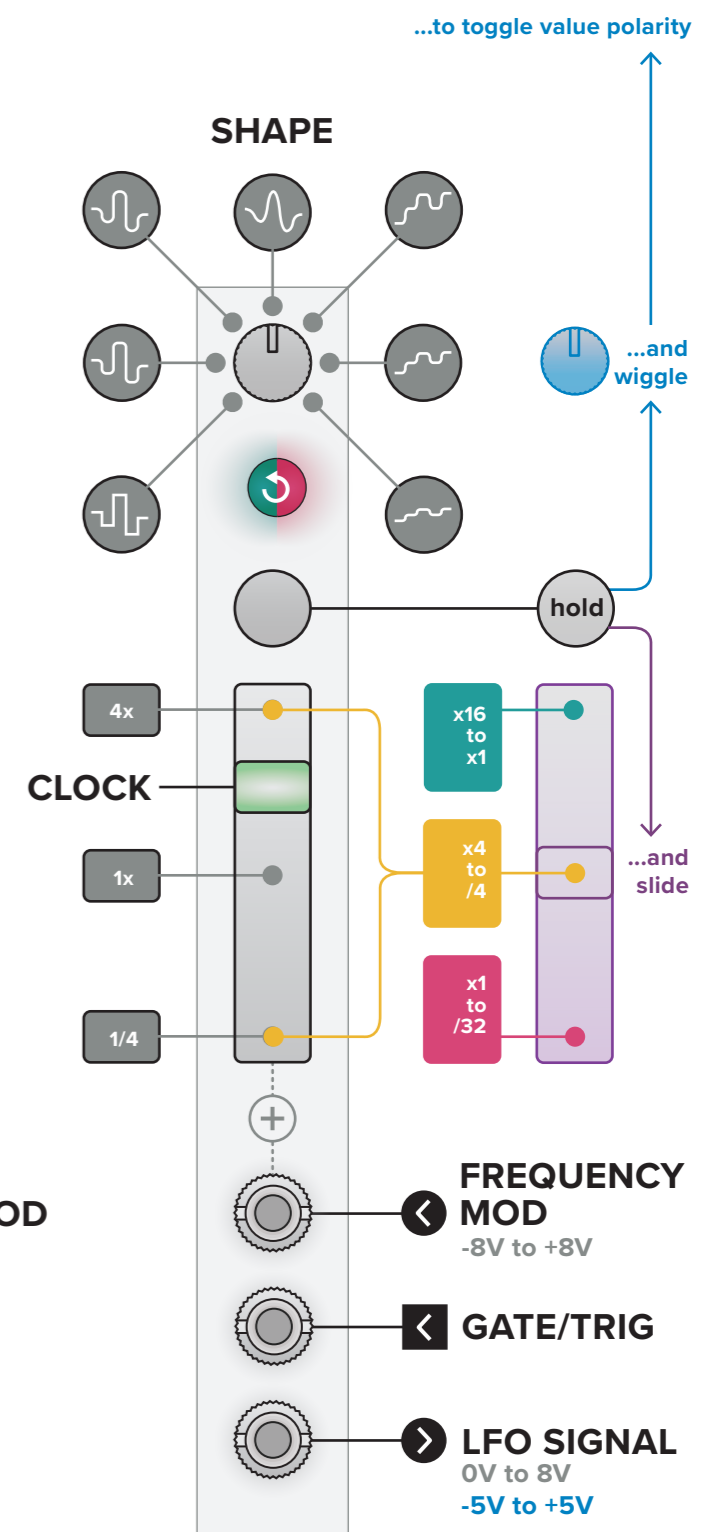

CLOCKED RANDOM LFO

STAGES QIEMEM — DAHDSR Mode

- (n) is in D/A/H/D
- (n) is in SUSTAIN
- (n) is in RELEASE

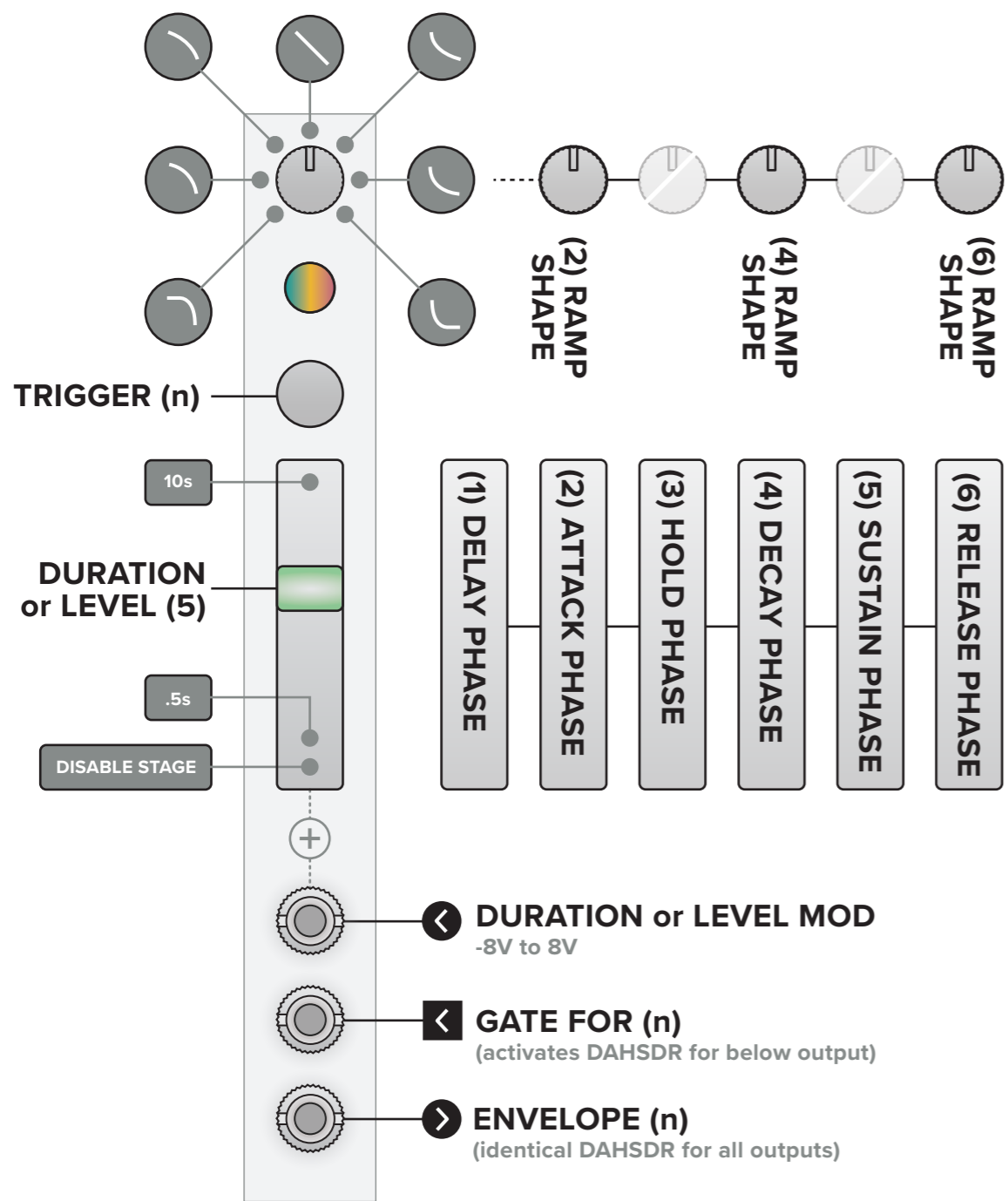

ENVELOPE (n)

Harmonic Oscillator Mode Alt. Harmonic Oscillator

- SAWTOOTH
- SQUARE, SHORT PULSE
- SQUARE, SHORTER PULSE
- SINE
- TRIANGLE
- SQUARE

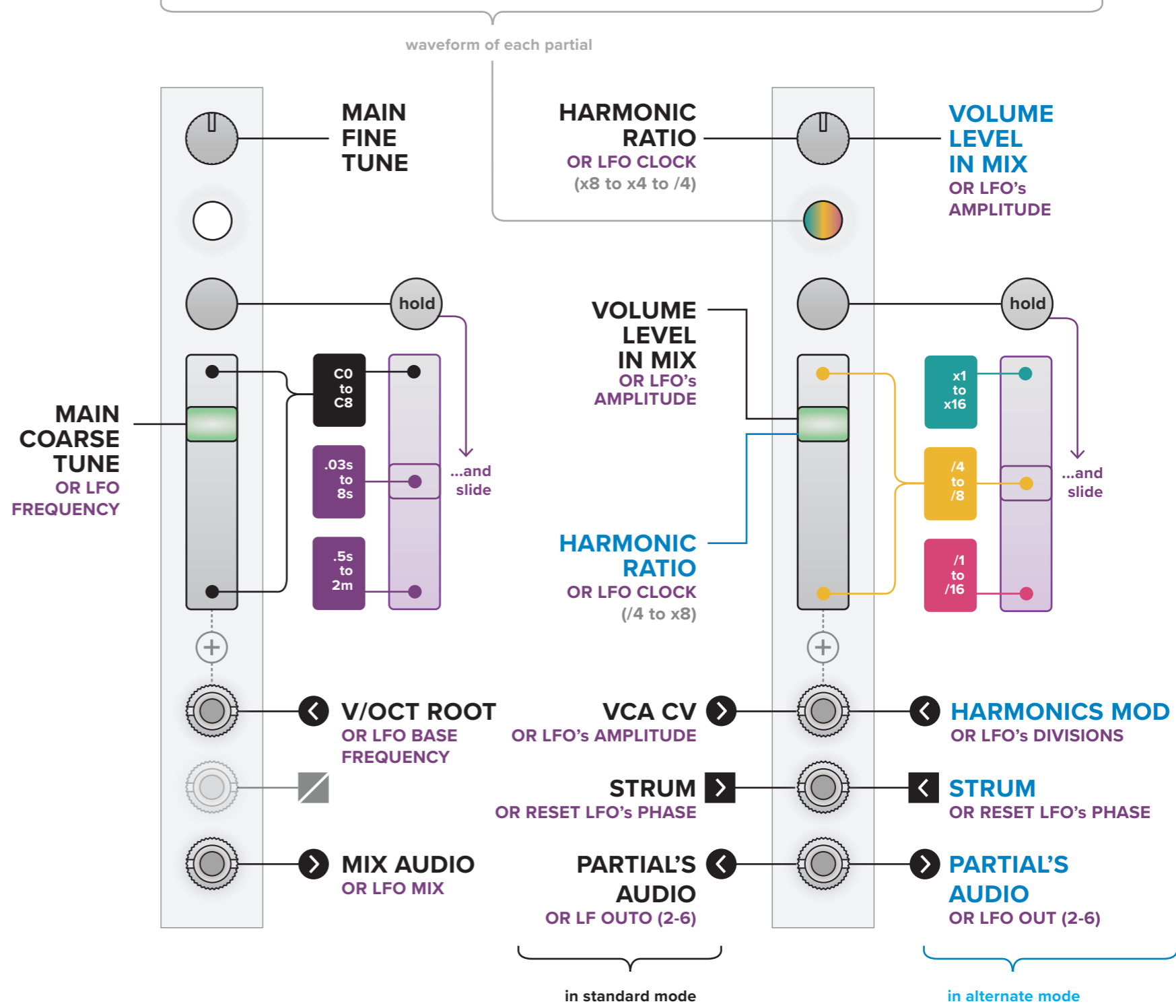

MAIN (1st)

PARTIALS (2-6)

STAGES QIEMEM — Extended Sequencer Groups

STAGES — Common Configurations

SEQUENCE PLAYBACK

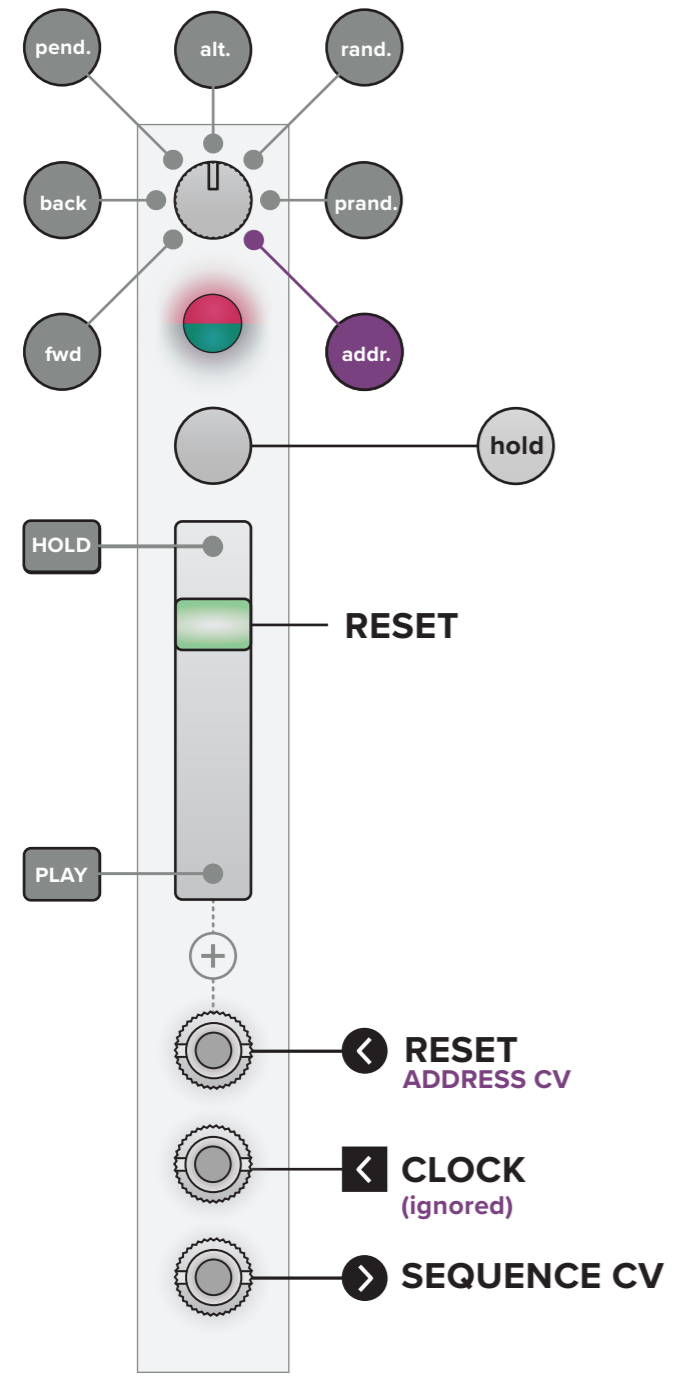

SLEW

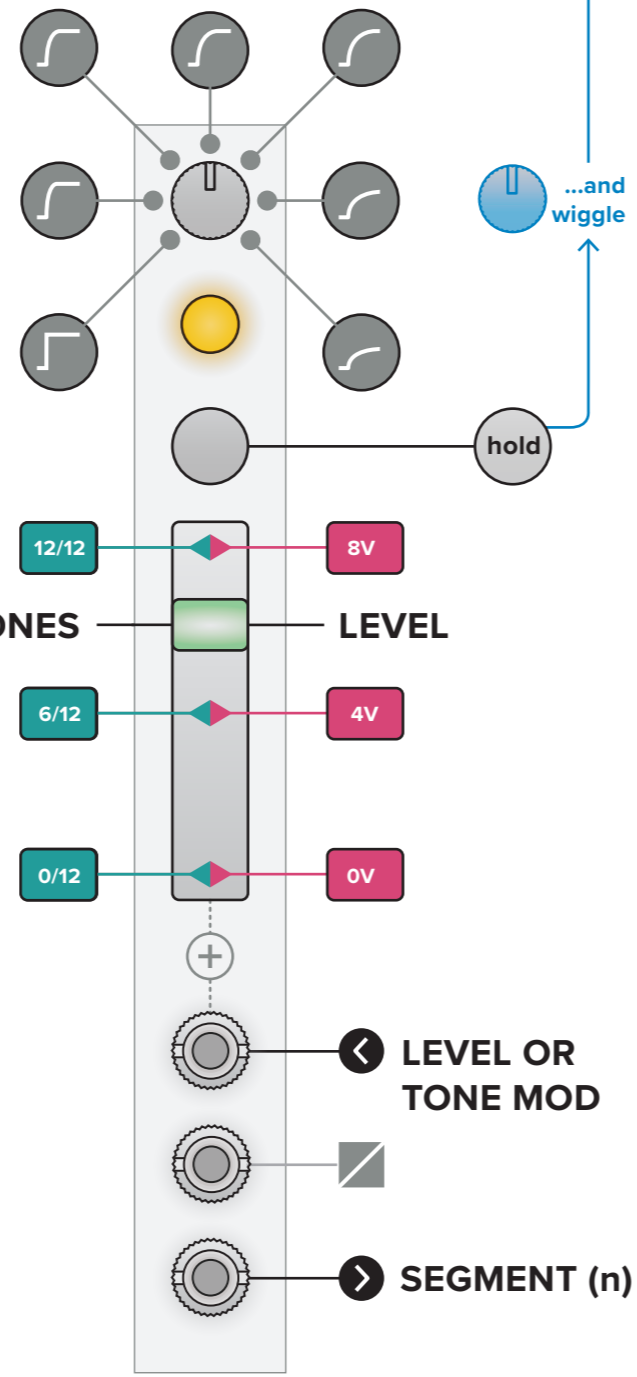

...to toggle slider's polarity
...and wiggle

