

Issue #33: Implementation of GSE

Idea of Quantum Error Mitigation

 Recover clean expectation value via **classical postprocessing**.

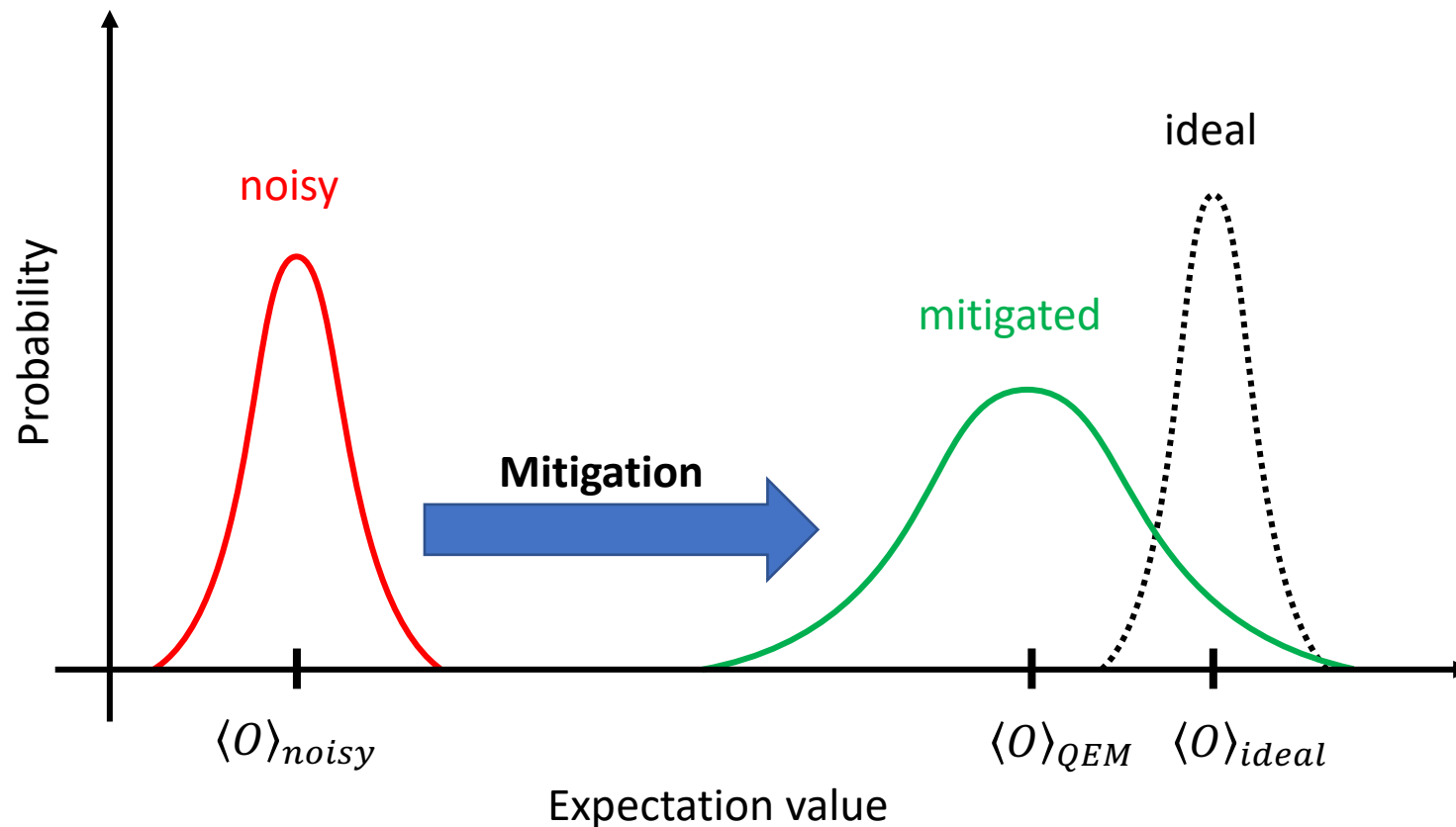

Purification-based method

Subspace Expansion

[McClean et al.,
Nature Communication, 2020]

Exponential Error Suppression

[Koczor, PRX, 2021] /

Virtual Distillation

[Huggins et al, PRX, 2021]

Zero-noise Extrapolation

[Temme et al., PRL, 2017]

QEM for coherent error

QEM for stochastic error



Generalized Subspace Expansion

[Yoshioka et al., PRL, 2022]

- Generalization of error-agnostic QEM methods → wide applications
- QEM for both **coherent/algorithmic** error and **stochastic** error

One of the strong tools for near-term quantum computation!!

Demonstration on Simulator

- red line: without any QEM
- blue line: with GSE

4-qubit GHZ

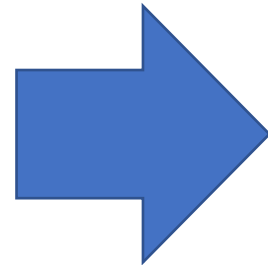
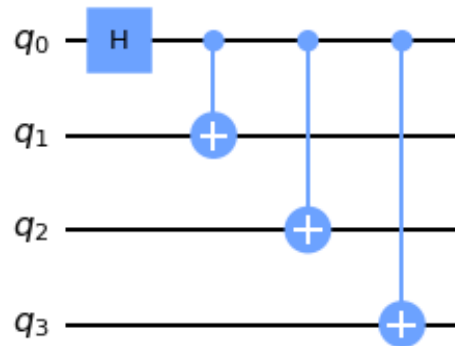

The ground state of

$$H = -ZZII - IZZI - IIZZ - XXXX$$

Ideal expectation value is

$$\langle GHZ|H|GHZ\rangle = -4.0$$

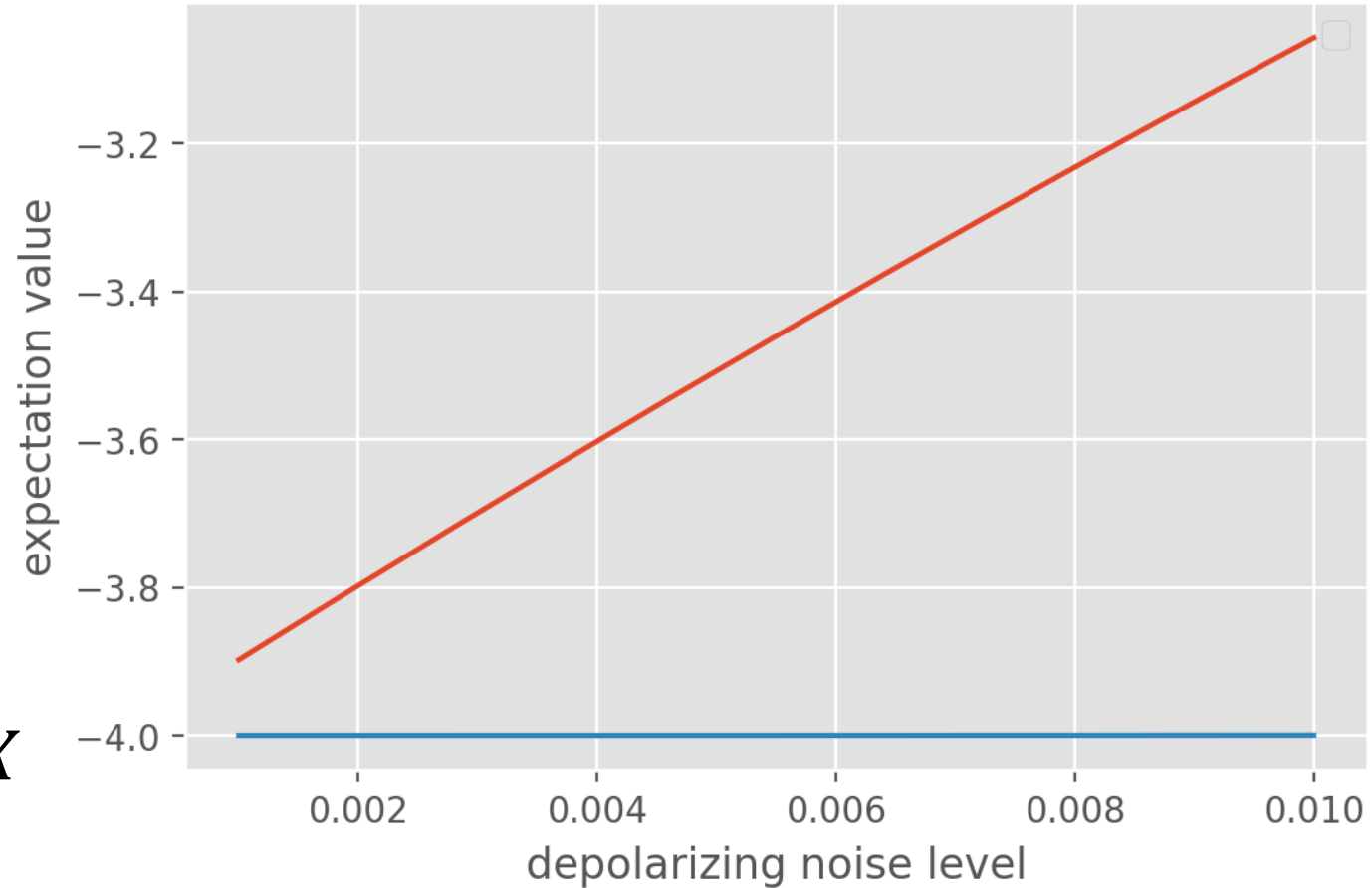

Demonstration on ibmq_jakarta

4-qubit GHZ

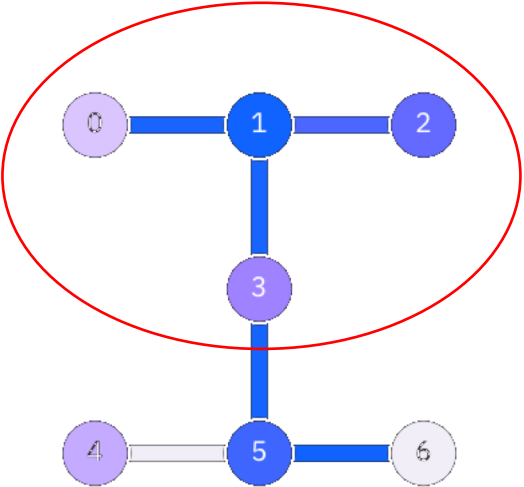
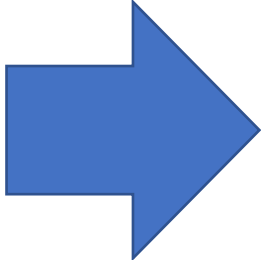
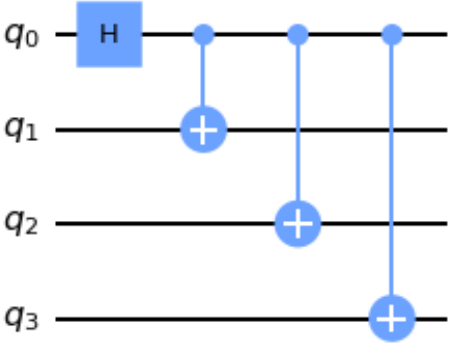

raw expval: -3.3853
 mitigated expval: -3.2288

The ground state of $H = -ZZII - IZZI - IIZZ - XXXX$

Ideal expectation value is

$$\langle GHZ | H | GHZ \rangle = -4.0$$

(System size might be too small
 → noise effect wins the mitigation effect)

Plan for Checkpoints 2 and 3

In October:

Apply GSE to the noisy result of VQE solver

- for the Ising model and other systems
- on IBM Quantum devices.

Generalize and refactor the implementation of GSE and its internal gadgets.



Deeply connected with the issue #3:
implementation of virtual distillation

In November:

Add the demonstration and documentation of GSE to qiskit-research

File/Folder	Commit Message	Date
kevinsung Merge pull request #40 from kevinsung/bump...		yesterday 423
.github/workflows	remove development version CI workflow	15 days ago
check	add and run notebook format script	3 months ago
docs	increase nbsphinx timeout from 500s to 100...	yesterday
qiskit_research	fix aer import	15 days ago
test	Merge branch 'main' of github.com:qiskit-re...	2 months ago
.gitignore	Fix dd	3 months ago
.pylintrc	pin some requirements	3 months ago