

# **RoboCup Logistics League**

## **Rules and Regulations 2019**

---

### **The Technical Committee 2012–2019**

<b>Vincent Coelen</b>	<b>Christian Deppe</b>	<b>Mostafa Gomaa</b>
<b>Till Hofmann</b>	<b>Ulrich Karras</b>	<b>Tim Niemueller</b>
<b>Alain Rohr</b>	<b>Thomas Ulz</b>	
Daniel Ewert	Nils Harder	Sören Jentsch
Nicolas Meier	Sebastian Reuter	Wataru Uemura
Gerald Steinbauer	Tobias Neumann	

Revision Date: Wednesday, April 10<sup>th</sup> 2019

# Contents

<b>1</b>	<b>Introduction</b>	<b>1</b>
1.1	The Task . . . . .	2
1.2	Agreements & Regulations . . . . .	2
1.3	Rules Philosophy . . . . .	2
<b>2</b>	<b>League Administration</b>	<b>3</b>
2.1	Technical Committee 2019 . . . . .	3
2.2	Organizing Committee 2019 . . . . .	3
2.3	Executive Committee 2015–2019 . . . . .	3
2.4	Website and Mailinglist . . . . .	3
<b>3</b>	<b>Competition Area</b>	<b>4</b>
3.1	Field Layout and Dimensions . . . . .	4
3.1.1	Moving on the Field . . . . .	4
3.2	Machines . . . . .	6
3.2.1	Markers . . . . .	9
3.2.2	Machine Positioning . . . . .	9
3.2.3	MPS — During Exploration Phase . . . . .	11
3.2.4	MPS — During Production Phase . . . . .	11
3.3	Products and Workpieces . . . . .	13
<b>4</b>	<b>Referees</b>	<b>14</b>
4.1	Referee Delegation . . . . .	14
4.2	Tasks and Responsibilities . . . . .	14
4.3	Liability Waiver . . . . .	15
4.4	Complaint Procedure . . . . .	15
<b>5</b>	<b>Game Play</b>	<b>15</b>
5.1	Environment Setup . . . . .	15
5.2	Interruptions and Robot Maintenance . . . . .	16
5.3	Game Start . . . . .	17
5.4	Setup Phase . . . . .	17
5.5	Exploration Phase . . . . .	17
5.6	Production Phase . . . . .	17
5.6.1	Production, Color Complexities, and Additional Bases . . . . .	17
5.6.2	Production Plan . . . . .	18
5.6.3	Machine Refill . . . . .	20
5.7	Special Events during a Match . . . . .	20
5.7.1	Scheduled Machine Downtime . . . . .	20
5.7.2	Broken Machine Downtime . . . . .	21
5.8	Task Fulfillment and Scoring . . . . .	21
5.9	Obstruction Penalty . . . . .	22
5.10	Pushing Rules . . . . .	22

<b>6</b>	<b>Tournament</b>	<b>25</b>
6.1	Tournament Phases . . . . .	25
6.1.1	Round-Robin phase . . . . .	25
6.1.2	Playoffs . . . . .	25
6.1.3	Finals . . . . .	26
6.1.4	Overtime . . . . .	26
6.2	Game Commentary . . . . .	26
6.3	Penalties . . . . .	26
6.4	Technical Challenges . . . . .	26
6.4.1	Markerless Machine Recognition and Production . . . . .	26
6.4.2	Playing in Simulation . . . . .	28
6.4.3	Open Challenge . . . . .	29
6.4.4	Conducting the Challenges . . . . .	29
<b>7</b>	<b>The Robotino System</b>	<b>30</b>
7.1	Markings . . . . .	30
<b>8</b>	<b>Communication</b>	<b>30</b>
8.1	Bandwidth Allocation . . . . .	31
8.2	Referee Box (refbox) . . . . .	31
8.3	Remote Control . . . . .	31
8.4	Monitoring . . . . .	31
8.5	Inter-robot Communication . . . . .	32
8.6	Communication Eavesdropping and Interference . . . . .	32
8.7	Wifi Regulations . . . . .	32
<b>A</b>	<b>Engineering Reference</b>	<b>33</b>
A.1	The Mobile Robot System Robotino 3 . . . . .	33
A.1.1	Robot Dimensions (w/o extension tower) . . . . .	33
A.1.2	Drive Unit . . . . .	33
A.1.3	Sensors . . . . .	34
A.1.4	Controller Board . . . . .	34
A.1.5	Power supply . . . . .	35
A.1.6	Software . . . . .	35
A.1.7	Wifi equipment . . . . .	36

# 1 Introduction

The future of industrial production lies with smarter systems. Manufacturing industries are on the brink of widely accepting a new paradigm for organizing production by introducing perceiving, active, context-aware, and autonomous systems. This is often referred to as Industry 4.0 [**Industry-4.0**], a move from static process chains towards more automation and autonomy. The corner stones for this paradigm shift are *smart factories*, which is a context-aware facility in which manufacturing steps are considered as services that can be combined efficiently in (almost) arbitrary ways allowing for the production of various product types and variants cost-effectively even in small lot sizes, rather than the more traditional chains which produce only a small number of product types at high volumes [**RCLL-CPS**]. Such factories will require a much more capable logistics system, of which the most flexible form are autonomous mobile robots.

The RoboCup Logistics League (RCLL) is determined to develop into a state-of-the-art platform for mobile robotics education and research tackling this problem of flexible and efficient production logistics at a comprehensible size. This industrial motivated league focuses on challenges promoting precise actions and robust long-enduring execution, and further encourages external data supported autonomy. By providing feedback and competition hardware, Industrial partner Festo provides insights into future factory concepts to help uncover relevant future topics for education and research.

This year's competition is laid out in the following pages. It ensures the same and fair circumstances for all participants. It neither dictates nor suggests the way how to fulfill the task, but is meant to develop the RCLL further. Smart Factory environments require new concepts of flexibility, awareness and optimization from autonomous entities working in an environment with specified, yet to some degree uncertain and dynamic, agency. This includes current challenges of developing industry-wide standards for Cyber Physical Systems for production processes like designing plug-and-produce capable systems. Opposed to numerous approaches regarding production infrastructure, RCLL aims to provide concepts for smart production logistics.

After exciting competitions in the previous years, we look forward to a new scale of competition that will emerge from initiatives around the globe. In 2012 we had our first Logistics League World Champion. In 2013 we introduced the Referee Box (refbox) [**RCI-RefBox**] changing the competition at its core by introducing a flow of information. This allowed for more dynamic games and the automatic tracking of scores. In 2014, we merged the formerly separate playing fields into a single field on which both teams compete simultaneously, introducing the need for self-localization, collision avoidance, and increased spatial coordination complexity. Additionally, the production schedules became more dynamic in that orders were posted dynamically and less frequently. In 2015 we introduced actual physical processing machines based on the Festo Modular Production System (MPS) requiring more complex machine handling [**wdr12013**]. The production schedule has again become more flexible and dynamic, by introducing color-coded rings of which a varying number can be requested to be mounted in a specific order for a certain product. This increased the number of products from 3 to about 240. After three years of constant and tremendous changes, 2016 was a year to consolidate our league as a whole by increasing the number of participating teams and allowing existing teams to excel in their capabilities. In 2017, we changed the field size and zone layout and we shifted the focus from the exploration to the production phase. In 2018, we saw more and more teams successfully delivering orders, even of higher complexity. For 2019, the TC is working towards a barcode recognition system to track products, which allows to automate scoring and to grant partial points for production steps. Additionally, we are working towards a more robust competition by replacing the communication with the MPS stations by new hardware and software.<sup>1</sup> The introduction of com-

---

<sup>1</sup>We gratefully thank the RoboCup Federation for supporting the work on workpiece tracking and network robustness.

petitive orders aims to increase the competition aspect by giving a bonus to the team that delivered first, thereby promoting strategic reasoning to gain an advantage over the other team. Also starting this year, we allow teams to purchase additional robot maintenance, which will increase overall game activity while posing an additional strategic challenge to the teams.<sup>2</sup>

## 1.1 The Task

Our aim is to provide a simplified Smart Factory environment. The teams must complete the following task without human interference, competing with a second team against the clock. In the RCLL, autonomous robot agents have to handle the logistics of materials through several (dynamic) stages to produce final goods to fulfill orders. The machines are specific MPS stations.

The Logistics League’s main challenge is a multistage production cycle of different product variants with self-crafted intermediate products and delivery of final products.

This is not true currently with intermediate scoring. To return to this objective, one could award points for mounting a last ring on delivery only

This genuine goal will be rewarded considerably higher than partial fulfillment of the task. Autonomous robots transport small products between the processing machines. Machines are MPS stations which complete a particular refinement step like mounting a colored ring or top-most cap. If procurable this will lead to a new sub-assembly or final product (cap). Complete work orders require all related sub-assemblies of product variants (cf. Section 5.6.1).

This work flow is controlled by a referee box broadcasting information via wifi (see Section 8.2). The work flow itself is divided into three different phases: a setup phase (see Section 5.4), an exploration phase (see Section 5.5) during which robots receive scores for correctly discovering and publishing the positions of the yet unknown different machines on the field. After this phase the referee box will announce all machine types and designations. In the following production phase (see Section 5.6) orders are announced by the referee box, which the robots must fulfill automatically.

Finally, successfully assembled products are to be delivered to the correct conveyor belt of the team’s delivery station. The factory area has to be treated in the best possible way. Any possible damage to the field, opposing robots or the machines will be penalized by the referee.

## 1.2 Agreements & Regulations

In the RCLL, all teams are obliged to use the Robotino robotic system from Festo Didactic SE with certain freedoms and limitations. This includes the current version, Robotino 3, as well as the phased-out Robotino 2. Section 7 describes the specific constraints.

## 1.3 Rules Philosophy

The goal of this industrially inspired league is to complete the tasks as quickly and reliably as possible. Each team should act within the meaning of a cooperative and fair behavior, even if everyone wants to be the better one. Teams should not search for gaps or inconsistencies in the rulebook to achieve advantages in the competition. Instead, we ask explicitly to bring such gaps to our attention. Since the rulebook cannot cover all possible cases, we consider a general gentleman agreement: “One should treat others as one would like others to treat oneself”.

The general development of the rules loosely follows a tick-tock rhythm, where years of larger rule modifications are followed by a year of stabilization and conservative changes.

---

<sup>2</sup>A list of rule changes can be found at <https://github.com/robocup-logistics/rcll-rulebook>

## 2 League Administration

### 2.1 Technical Committee 2019

The technical committee (TC) is responsible to update and publish the rulebook, to decide on technical questions during the tournament, and to communicate with the league stake holders on technical advancements. Current members of the TC are (in alphabetical order):

*Vincent Coelen*, Ecole polytechnique universitaire de Lille

*Christian Deppe*, Festo Didactic SE, Denkendorf, Germany

*Mostafa Gomaa*, RWTH Aachen University, Aachen, Germany

*Till Hofmann*, RWTH Aachen University, Aachen, Germany

*Alain Rohr*, HFTM Technical Institute of Applied Science Mittelland, Biel, Switzerland

*Thomas Ulz*, Graz University of Technology, Graz, Austria

To get into contact with the TC use the mailing list

`robocup-logistics-tc@lists.kbsg.rwth-aachen.de`

### 2.2 Organizing Committee 2019

The organizing committee (OC) is responsible for organizing the RoboCup competitions, to communicate to the RoboCup Federation trustees and chairs the requirements of the league, and to inform and attract new teams to the league. Current members of the OC are (in alphabetical order):

*Stefan Brandenberger*, HFTM Technical Institute of Applied Science Mittelland, Biel, Switzerland

*Vanessa Egger*, Graz University of Technology, Graz, Austria

*Wataru Uemura*, Ryukoku University, Japan

To get into contact with the OC use the mailing list

`robocup-logistics-oc@lists.kbsg.rwth-aachen.de`

### 2.3 Executive Committee 2015–2019

Executive Committee members are responsible for the long term goals of the league and thus have also contact to other leagues as well as to the RoboCup federation. The Executive Committee presents the league and its achievements to the RoboCup federation every year and gets feedback to organize the league. All committee members are also members of the Technical Committee. Executive Committee members are elected by the Board of Trustees and appointed by the President of the RoboCup Federation; they serve 3-year terms.

*Ulrich Karras*, priv. Dozent, Essen, Germany

*Tim Niemueller*, RWTH Aachen University, Aachen, Germany

### 2.4 Website and Mailinglist

The website of the RoboCup Logistics League is available at

`http://www.robocup-logistics.org`

A mailing list for general announcements and discussion about the league is available at

`https://lists.kbsg.rwth-aachen.de/listinfo/robocup-logistics`

## 3 Competition Area

### 3.1 Field Layout and Dimensions

The competition area is shown in Figure 1 and features a  $14\text{ m} \times 8\text{ m}$  large arena with 106 square zones of  $1\text{ m} \times 1\text{ m}$  with 14 randomly distributed machines. The field is partially surrounded (at least 50% but not more than 70%) by wall elements of at least 0.5 m height. The origin and coordinate system of the competition field is drawn in Figure 1 and will be intrinsically referred to for each statement within this rulebook. The normal floor of the exposition-rooms is used, it will be reasonable flat.

Belongs to section 'Moving on the Field'

The entire area is shared among both teams on the field and any robot may travel anywhere at any time (while not obstructing for an extended period of time or pushing other robots or machines). However, there are primary sides (split along the y-axis) for each team where a team's *robot insertion area*, and *Base, Storage and Delivery Stations*, are located. We will refer to the side with positive coordinates on the x-axis as the (primary) half of team cyan, and the side with negative coordinates on the x-axis as the primary half of team magenta.

Move up to field layout + this sounds confusing, because the main game area is not specified, it may sound like the insertion zone is outside of the 14mx8m area. Maybe describe its location in the corner, write in section 'Moving on The field\*', that the insertion zone should not be driven to during the game

The robot insertion areas (gray area on Figure 1) are outside of the main game area. All 14 machines, 7 per team, are placed within the factory area as stated in Figure 1. Machines have two kind of sides: active (wide, where the robot interacts) and ignored (narrow) edges. The constraints for positioning of the MPS are given in Section 3.2.2.

The distribution and alignment of all machines is axially symmetrical to the y-axis. Thus, each team has similar conditions on both halves of the competition field. Both teams have an exclusive set of 7 out of the 14 machines each. Machines from one team can also be located on the primary side of the opposing team. We will later discuss the concept of the production machine distribution for each team in detail.

The center coordinates and the size of the zones in which the machines are placed can be seen in Figure 1. The zone names are structured as a team prefix ("C-" for cyan, "M-" for magenta), Z to distinguish zone names, and a grid coordinate. For example, The zone C-Z23 is the zone on the cyan primary half, which is the second along the X-axis and the third along the Y-axis. Zones are only a means to position machines. They will not be physically represented or visible on the field. They cannot be used for any other purpose.

Note that this specific field layout is an example only, accounting for symmetry and avoiding clustering of machine access nodes and unapproachable machines. However, the actual distribution and alignment of machines on the competition area will change before the actual game starts and will be different for each game. Thus, teams should focus on a generic approach for production, allowing for dynamic adaptation of machine positions and alignments.

#### 3.1.1 Moving on the Field

The robots are free to move on the field. However, robots may not leave the main area (surrounded by the partial walls). That is, when connecting all wall segments with the shortest possible edges, robots

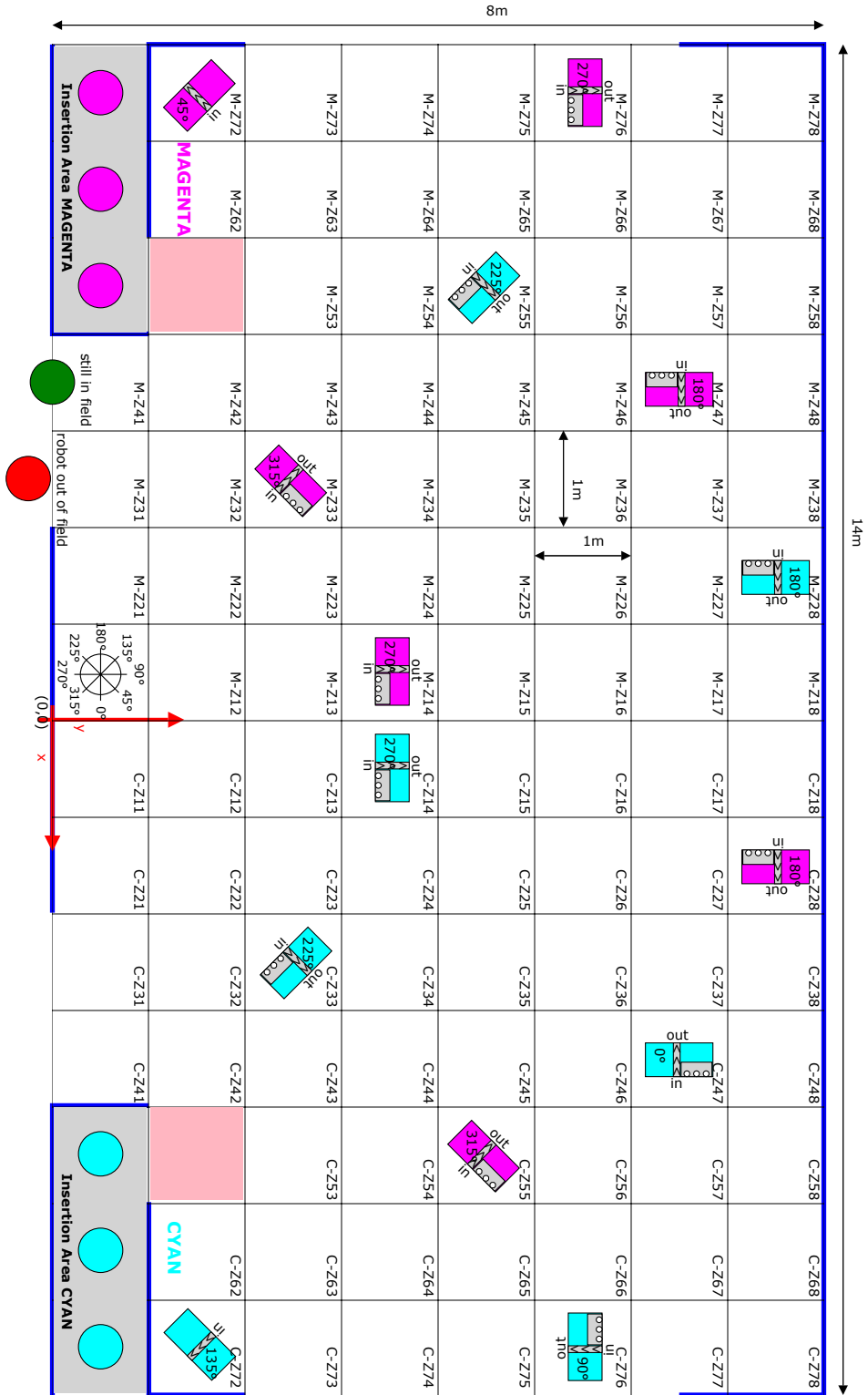

Figure 1: Competition area: squares indicate zones for possible machine placements, circles denote robots. Cyan and magenta are team assignment colors. Thick blue lines are wall elements. The green robot is at an acceptable position, while the red one would have to be penalized for leaving the field. Grey areas are insertion areas where robots start. No machines may be placed in the light-red areas.



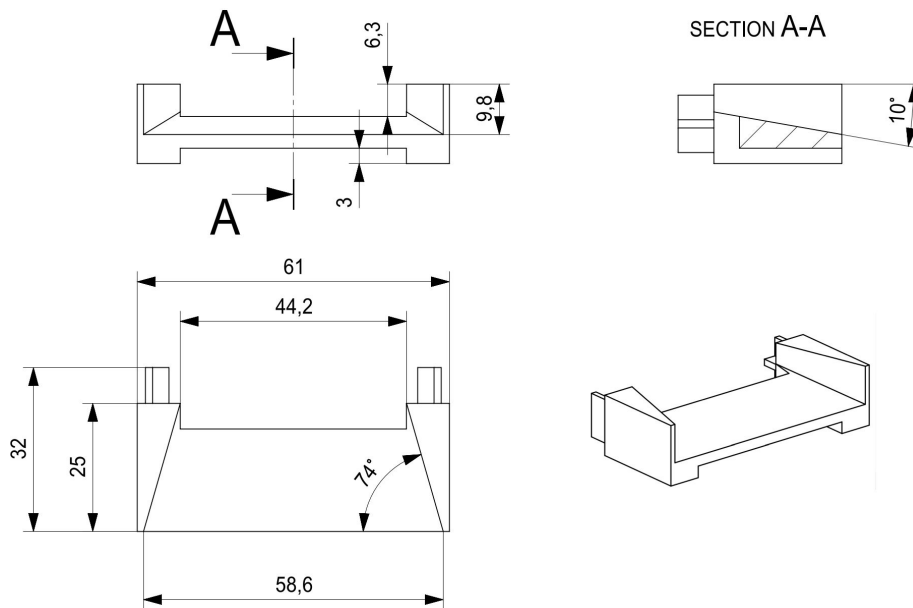

Figure 2: Narrowing cone

may not move such that the base is fully outside this area. For example, in Figure 1, the red robot is outside the intended area and thus in an illegal position.

Robots that leave the competition area illegally are considered as *misbehaving robot* and punished accordingly (cf. Section 5.2).

### 3.2 Machines

Machines are based on the Modular Production System (MPS)<sup>3</sup> by Festo Didactic SE. The MPS provides a number of stations which make up the machines used in the competition. The stations have a rectangular base shape of 0.35 m × 0.7 m with a height of about 1 m depending on machine type. The machine has individual application modules that provide different functionality.

All machines share the same basic layout: a trolley, conveyor belt, and signal light. A machine is movable by four wheels with 0.1 m clearance. Both narrow sides of the trolley are closed by plexiglas and have a handle. All physical interfaces like conveyor belt inputs and outputs, shelves, and slides for additional bases on ring stations are accessible at 89.8 cm height.<sup>4</sup>

add 'on the conveyor-belt' since guiding lanes are not mentioned before

**Working space between guiding lanes is 4.5 cm.** Setup lanes and shelves feature approximately the same space for handling and adjusting. All diffuse sensors (input side) have been removed to allow for infrared-emitting cameras. To simplify the delivery on the belt, each machine will be equipped with a narrowing cone on its input side (Figure 2). You can order them from Festo Didactic SE (C. Deppe) or download the STL model file from the RCLL site. Based on these shared properties, there are five kinds of machines:

**Base Station (BS)** acts as dispenser of base elements (Figure 3(b)). The application modules are three magazines of base elements. There is a single BS per team.

<sup>3</sup>For more information see <http://www.robotcup-logistics.org/links/festo-mps>.

<sup>4</sup>Note however, that due to small variances and unevenness in the floor there may likewise be small variances in the working height of some or all parts of a station.

Type	Distribution	(Final) processing time[s]
Base Station (BS)	1 per team	minimum physical time
Cap Station (CS)	2 per team	$t_2 = 15$ to 25 sec
Cap Station (CS)	2 per team	$t_2 = 15$ to 25 sec
Ring Station (RS)	2 per team	$t_3 = 40$ to 60 sec
Storage Station (SS)	1 per team	minimum physical time
Delivery Station (DS)	1 per team	$t_5 = 20$ to 40 sec

Table 1: MPS type, distribution and processing times

### Cap Station (CS)

Reword to emphasize its dual purpose, also mention the shelf. Proposed change:

can perform two different tasks:

1. retrieves a cap from a workpiece and stores it on the slide (can only store one cap at a time)
2. mounts a stored cap on a workpiece as final production step

The application module is a vacuum pick & place module. There is a slide to store at most one cap piece at a time. At the beginning this slide is empty. Additionally, a shelf is located next to the input side of the conveyor belt. This shelf is initially filled with three capcarriers (transparent base + grey or black cap). There are two CS per team

Old text:

mounts a cap as the final step in production on an intermediate product (Figure 3(c)). The application module is a vacuum pick & place module. There is a slide to store at most one cap piece at a time. At the beginning this slide is empty and has to be filled in the following way. A base element with a cap must be taken to the machine and is then unmounted and buffered in the slide. The cap is then mounted on the next intermediate product taken to the machine.

**Ring Station (RS)** mounts one colored ring out of two available colors on an intermediate product (Figure 3(d)). Each RS has two vacuum pick & place units as application modules with separate unique colors which are determined new for each game. There is an additional pre-fill slide which is used for some colors (specified anew for each game) to add base elements. There are two RS per team.

**Storage Station (SS)** provides 24 slots of storage divided into 6 layers (Figure 3(e)). For now items can be shipped out on the output side on request. The Storage Station provides a sample of each possible  $C_0$  configuration (one per layer).<sup>5</sup>

**Delivery Station (DS)** Accepts completed products. The stations contains three slides (Figure 3(f)). The delivered products are verified by either the referees or an automated external vision system. There is one DS per team.

Machines of type CS and RS are called production machines as they perform refinement steps on a workpiece during the production phase. Processing times are outlined in Table 1.

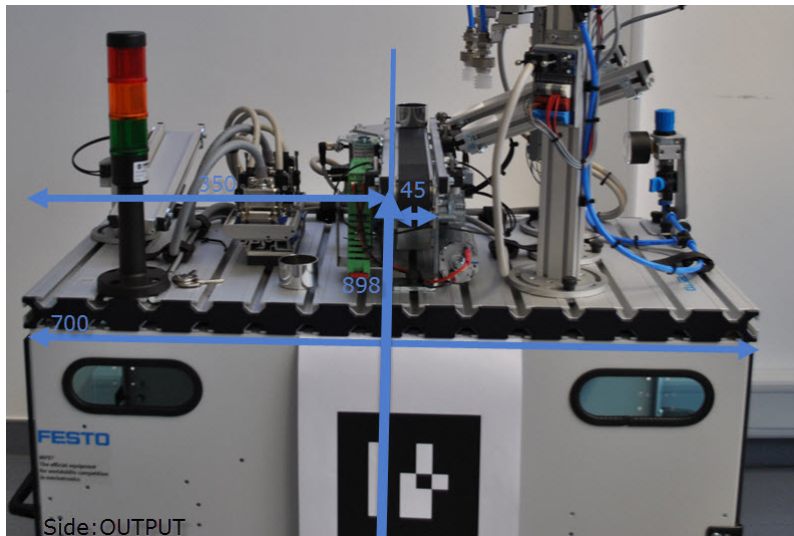

(a) General Machine Layout



(b) Base Station

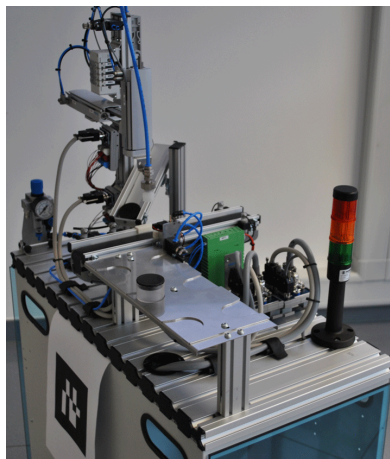

(c) Cap Station



(d) Ring Station



(e) Storage Station

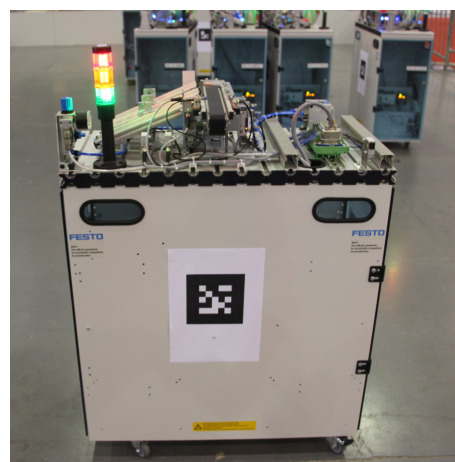

(f) Delivery Station

Figure 3: The different MPS stations

### 3.2.1 Markers

Each machine will feature two *markers* based on ALVAR AR tags, one will be placed on the input, another one on the output side. All markers used are depicted in Table 2.

#### Add marker size

The marker will be horizontally centered below the conveyor belt. The vertical distance (between tag and conveyor belt) will be about 35 cm.

#### Pictures do not match the description and new pictures should be taken to display the transparent markers

The markers will be mounted at the same position on all machines in a best effort fashion. But teams should expect to calibrate individually per marker. They are available for printing on the RoboCup Logistics website.

### 3.2.2 Machine Positioning

The zones and rotations for the MPS will be randomly chosen by the RefBox. Each game will have a new randomly generated field layout, the referees will place the MPS in the middle of the zone with given rotation at their best effort but errors of the positioning should be expected.

A MPS can be placed in any zones except C-Z52 and M-Z52. These zones are needed to enter the field. Each MPS has one out of 8 possible orientations, starting at  $0^\circ$  with steps of  $45^\circ$ . To denote the orientation, we assign a local right-handed coordinate system to each MPS station. The x-axis is given by the conveyor pointing from the output to the input. The origin is the center point of the

<sup>5</sup>Note that this is the specific content for 2019 and may change in the future.











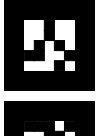

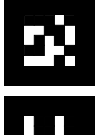

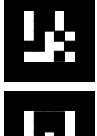

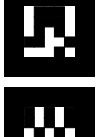

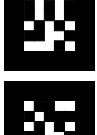
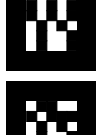
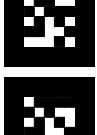
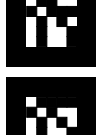

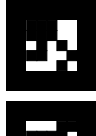



		Input		Output	
	Machine	ID	Tag	ID	Tag
Cyan	CS 1	1		2	
	CS 2	17		18	
	RS 1	33		34	
	RS 2	177		178	
	BS	65		66	
	DS	81		82	
	SS	193		194	
Magenta	CS 1	97		98	
	CS 2	113		114	
	RS 1	129		130	
	RS 2	145		146	
	BS	161		162	
	DS	49		50	
	SS	209		210	

Table 2: Machine tags are ALVAR tags with the given IDs.

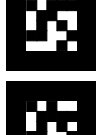

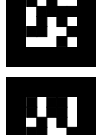
(a) For rotations with  $0^\circ$ ,  $90^\circ$ ,  $180^\circ$  or  $270^\circ$ . BS, CS, RS, and SS block the zones close to the input as well as the output. DS blocks the zones close to the input.

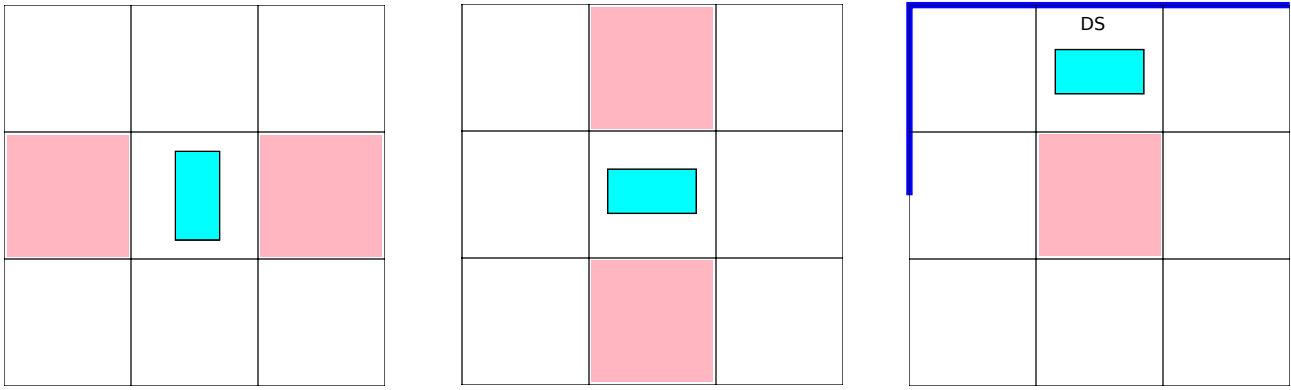
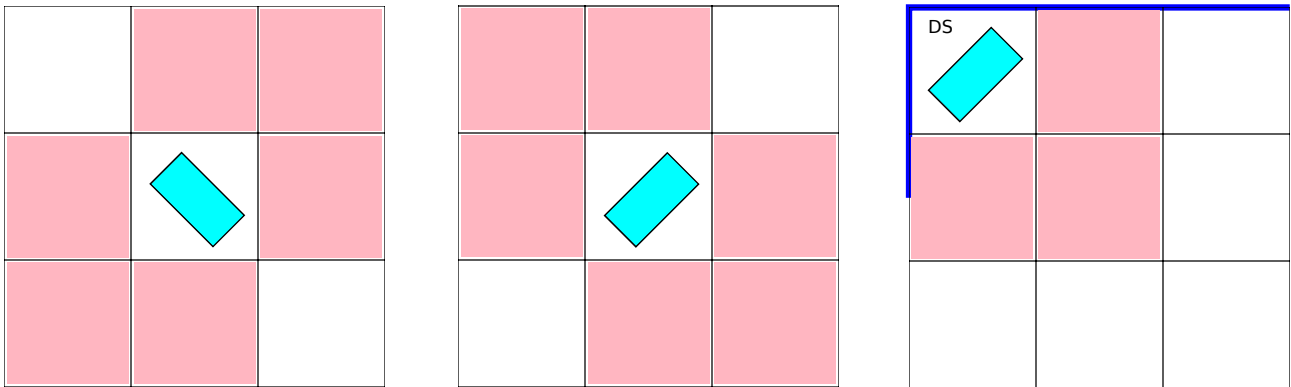

(b) For rotations with  $45^\circ$ ,  $135^\circ$ ,  $225^\circ$  and  $315^\circ$ . BS, CS, RS, and SS block the zones close to the input as well as the output. DS blocks the zones close to the input.

Figure 4: Blocked zones regarding the MPS rotation (red zones must not be used as position for other machines and must be located inside the competition area).

conveyor. The orientation is then the relative rotation of the local MPS system compared to the fixed field coordinate system. For example, at an MPS orientation of  $0^\circ$ , its local coordinate system is aligned with the field (in terms of orientation). Furthermore, an MPS at an orientation of  $90^\circ$  will be rotated counter-clockwise a quarter turn compared to the field system.

To ensure fairness, positions and orientations of the machines are mirrored along the field's y-axis. There are two cases that need to be handled separately. First, machines in a cell not adjacent to the wall, and machines of types BS, DS, and SS (even when adjacent to the wall) are mirrored according to Table 3. Second, CS and RS stations must be handled slightly different, if oriented next to a wall (zones: C-Z\*1, C-Z\*8, C-Z7\*, M-Z\*1, M-Z\*8 and M-Z7\*). The reason being, that the shelf and slide of these stations are offset sideways at the input side. This might lead to the situation that for one team the shelf is close to the wall, and for the other it is not. To remedy this problem, the RS and CS machines adjacent to a wall will always be placed such that the shelf or slide is on the farther end with respect to the wall. For example, in Figure 1, the magenta CS in M-Z76 with a rotation of  $270^\circ$ . Were this setup mirrored, the shelf on the cyan CS in C-Z76 would be close to the wall. Instead, it has a different orientation violating the y-symmetry but allowing for easier access to the shelf.

For placing of machines, the RefBox will take care of the necessary constraints to ensure that all in- and output sides, shelves and slides are reachable. That is, a path to each blocked zone (see Figure 4) must exist from any unoccupied or blocked zone of the field. If a machine is rotated with  $0^\circ$ ,  $90^\circ$ ,  $180^\circ$  or  $270^\circ$  the zones in front the input and output side are blocked as well (Figure 4(a)). For

Optical Feedback	Operating mode
All LEDs turned off	The machine is physically offline, caused by a real error, which should not happen during the competition.
Red LED turned on	The machine is out of order.
Green LED turned on	The machine is idle and ready.
Green LED flashing	The machine has accepted the prepare command (flashes for up to 3 seconds).
Green and yellow LED turned on	The machine is currently busy.
Yellow LED turned on	A workpiece is ready for pickup.
Red and yellow LED flashing (2 Hz)	Machine is broken, for example because a product was fed without proper preparation of the machine.

Table 4: MPS — Optical Feedback during production phase

machines with rotations  $45^\circ$ ,  $135^\circ$ ,  $225^\circ$  and  $315^\circ$  three zones in front of each input and output side are blocked (Figure 4(b)). No MPS nor blocked zones for another MPS may be placed in a blocked zone. All blocked zones of any MPS must be located within the competition area. Furthermore, only two machines will ever be placed next to each other, a third machine will only be placed with at least one empty zone in-between.

The MPS will be placed mostly on the primary half of a team (cf. Section 3.1). However, some machines will be swapped, that is, some machines will not be located in the primary half.

For each game, one CS and one RS of each team will be chosen randomly and swapped with the corresponding machine of the other team on the non-primary half — that is two machines in total per team. The CS and RS will be swapped with the symmetrically positioned machine of the same type of the other team. For consecutive games, the changes to the machine to zone assignment may be limited by the referee box in order to reduce the time needed to implement the layout during the setup phase.

Cyan	Magenta
$0^\circ$	$180^\circ$
$45^\circ$	$135^\circ$
$90^\circ$	$90^\circ$
$135^\circ$	$45^\circ$
$180^\circ$	$0^\circ$
$225^\circ$	$315^\circ$
$270^\circ$	$270^\circ$
$315^\circ$	$225^\circ$

Table 3: MPS orientation mapping during mirroring

### 3.2.3 MPS — During Exploration Phase

During the exploration phase the robots of each team must explore the unknown factory environment to identify where the different MPS are located and in which rotations they are positioned.

The Referee Box assigns each machine to a team and a zone (Figure 1) at the start of the exploration phase,<sup>6</sup> The zones and orientations (in steps of  $45^\circ$ ) are randomly determined, and will not be communicated until the production phase. For details about the Exploration Phase confer Section 5.5.

The signal light of the MPS will show a yellow light until a report regarding this machine is sent. If the wrong MPS zone is sent, the light will start red flashing. If only the MPS zone is sent, the green light will be turn on. If the zone and rotation is correctly reported, the green light will be flashing and if the zone is correct but the rotation wrongly reported the red and green light will be on.

### 3.2.4 MPS — During Production Phase

In the production phase a production machine performs refinement steps on a product such as mounting an additional ring or a cap. Machines operate in a transaction style. That is, before using a

<sup>6</sup>Since 2017 there are no more fixed stations.

machine it must be prepared for a specific mode.

Sound like one has to 'prepare' before 'put'

Then the input products can be fed into the machine and the refinement step commences. Eventually, after the production period is completed, the resulting product is delivered on the output lane.

A light signal mounted near the output lane (cf. Section 3.2) indicates the state of the machine. In the default operating mode, the green light is turned on. This signals that the machine is ready for preparation. When preparation is performed, the machine will flash the green light for up to 3 seconds (it immediately switches to a new state, e.g., if a product is fed into the machine before the three seconds have expired). When a product is fed to the input, the signal light indicates the processing condition. If the machine accepts the input and starts processing, the green and yellow lights will be turned on steadily for as long as the processing is performed. Once processing completes, the signal light switches to a steady yellow light. If a product is fed for which additional bases were required but which have not been delivered, the machine will flash the red and yellow light and will be out of order (cf. Section 5.7.2). The light signals are summarized in Table 4.

In the production phase, machines must be prepared to be used. This applies to all machine types. The DS, CS and RS start the conveyor belt upon receiving a prepare message. If no workpiece reaches the machine operating point (indicated through the middle belt sensor) within 30 s, the machine goes to a temporary out-of-order state (cf. Section 5.7.2). The BS and SS will immediately dispense a workpiece upon receiving a prepare message. The workpiece may remain on the machine for an arbitrary time.

The following describes the communication and reactions of the machines during the production phase. For the actual messages we refer to the integrator's manual [[RefBoxIntManual](#)].

**BS** The BS prepare message denotes the color of the base element that should be dispensed. After receiving the message, the rebox will instruct the MPS to immediately provide a base of the desired color.

**DS** The DS prepare message denotes the order ID of the product that is delivered. The DS will consume any workpiece provided, but points can only be scored if the DS has been properly prepared.

**CS** The CS prepare message initiates either the retrieval or the mounting of a cap. For retrieving a prepared base (with a cap mounted on top) from the machine's shelf must be fed into the machine. All base elements prepared on the shelf are specially colored workpieces (clear). The machine will take the cap off the base and buffer it on the slide, releasing the decapped base to the output side. This base can only be used for providing an additional base to an RS (see below), reuse by placing it back on the shelf, or discarding it at the DS. For mounting a cap, a workpiece (without cap) must be provided onto which the cap is mounted.

**RS** The RS prepare message must state which of the two colors to prepare and retrieve. Each RS is responsible for two specific colors. Some colors require loading the RS with additional bases (cf. Section 5.6.2). If the desired color requires additional bases (cf. Section 5.6.1), the machine expects to receive them first. Once the required number of additional bases has been received, the intermediate product can be fed into the machine. It receives a ring of the desired color and moves the processed product to the output.

**SS**<sup>7</sup> The SS prepare message denotes the storage place where to store the next input workpiece, or from which place to retrieve an item from. There will be designated positions for specific  $C_0$  workpieces which will be announced at the beginning of the tournament.<sup>8</sup> If a position is requested for which no product has been stored (or has already been retrieved), the machine will be broken

<sup>7</sup>The TC is working towards the integration of the SS for 2019. Issues arising or the lack of development resources might lead to exclusion of the SS from the tournament on short notice.

<sup>8</sup>Please note again, this is an assignment specifically for 2019 and may change in future competitions.

(cf. Section 5.7.2). The products retrieved from the SS are only allowed for some specific order, cf. Section 5.6.2. Note the costs for retrieving a base outlined in Section 5.8.

The preparation and use of a machine follows a transaction style. Once the machine has been prepared, the full cycle can be completed (committed). There may be only one transaction running at a time. If a second preparation is performed the machine will be temporarily broken (cf. Section 5.7.2).

An MPS may be reset by a team at any time by a dedicated msg (see referee box Integrator's Manual [RefBoxIntManual]). This causes the MPS to go into the broken state (cf. Section 5.7.2). It allows teams to recover machines after handling errors (which the robots must recognize themselves).

### 3.3 Products and Workpieces

Workpieces denote raw material and intermediate stages during production. These are also named products with emphasis on the finished product that can be delivered. For product complexities refer to Section 5.6.1, for the compilation of the production plan to Section 5.6.2.

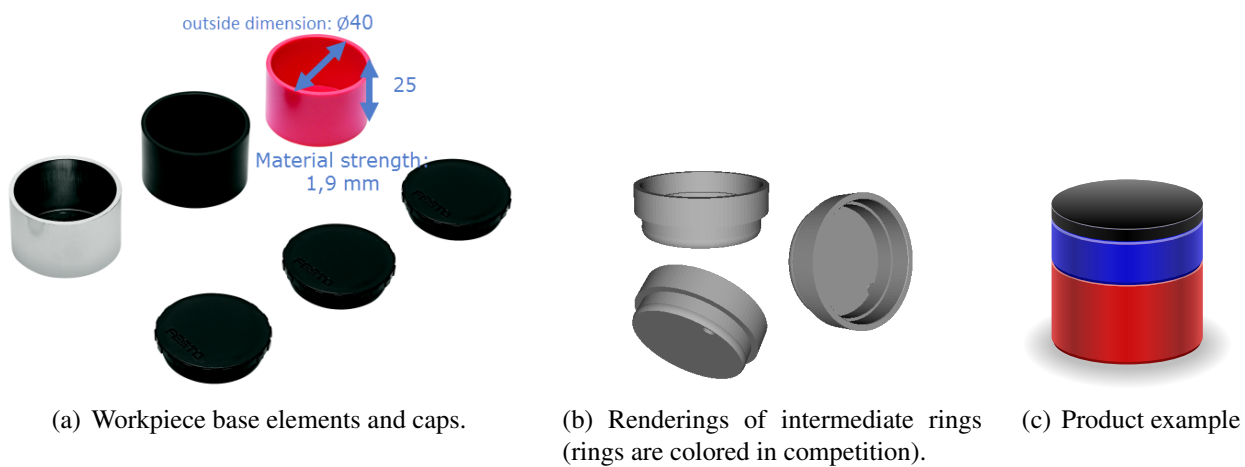

Figure 5: Workpiece elements and product example.

The workpieces consist of the following elements:

**Base** The base is the lowermost element in each production. Bases are dispensed by the base station (BS) and bases with mounted caps are available on the cap stations (CS). Bases are available in the colors red, black, silver, and transparent. Transparent bases are to be used and only used on CS shelves (cf. Section 3.2.4), they cannot be used as a workpiece for production. They may, however, be used to provide additional bases required by an RS, stored on a team's CS shelf, or recycled at the DS.

**Ring** Rings are mounted in intermediate production steps at ring stations (RS). A product requires, zero, one, two, or three intermediate rings of distinct color (cf. Section 5.6.1). The order of the rings matters. The ring colors are blue, green, yellow, and orange.

**Cap** Caps are the topmost element in each production. They are obtained by taking pre-assembled base-cap combinations available on the shelf to the cap station (CS). Caps can be black or gray.

Should be moved to a different section, this concerns robots not workpieces

Only one workpiece or a composite product must be grasped and transported per robot at once. Storage magazines on the robot or similar are prohibited. All products will incorporate exactly one base unit allowing a single unified handling device to be used for all operations involving workpieces.



**Barcodes.** All bases are labeled by a horizontally revolving, white glossy tag covering about 50 percent of the bases height (from the center) containing a white reference area as well as an identifying barcode. Each base is equipped with a unique ID. Figure 6 shows a prototype of a barcode labeled workpiece.

The barcodes are scanned at each station and communicated to the referee box. The referee box uses the barcodes to track assembly processes, i.e., to determine the state of a workpiece. This allows in particular to award points for production steps as they happen (cf. Section 5.8).

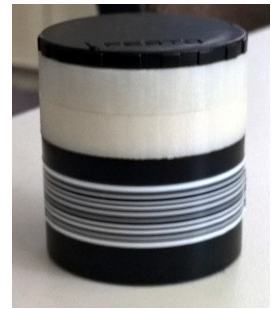

Figure 6: Prototype base barcode.

## 4 Referees

Referees manage the overall game, make sure that the rules of the game are followed, and instruct and monitor the referee box.

### 4.1 Referee Delegation

Each participating team of the tournament must provide at least two team members which act as referees. These referees must be announced at the beginning of the tournament and are fixed throughout the whole competition (unless the participant drops out of the tournament, e.g., because of illness). The referees must meet the following criteria. They must

- be available for each game that they are assigned to and appear 5 minutes prior to the game start time (schedule to be announced by Organizing Committee at beginning of the tournament)
- have good knowledge of the rulebook and the applied rules
- participate in the referee briefings (organized by Organization and Technical Committees)
- be able to lead a game and communicate with the teams in English.

### 4.2 Tasks and Responsibilities

Each game requires 3 referees. One referee will run and oversee the referee box. Two field referees observe the field, announce rule violations, and communicate with the teams and refbox referee. Each field referee is assigned to a particular field half. The referee named first on the schedule is the head referee and is responsible for the team cyan and their corresponding field half. The head referee has the upper hand when there is a referee disagreement and then announces the final decision. The second listed referee assumes the liability of the team magenta.

The refbox referee has to operate the control machine during the game, observe its status to ensure the correctness of the digital representation and automatic scoring, announce critical situations to the field referees, and start and stop the game on request of the field referees. The refbox referee must also enter robot restarts and observe the time remaining to bring back a robot, or announce if a robot may no longer participate in the game (second restart).

The field referees observe the game from the side of the field or from any position on the field (e.g., to better understand the game situation). They shall avoid robots spatially on the field, but ultimately robots are expected to avoid collision with human referees. Field referees are also responsible for removing fallen products from the playing-ground. Field referees are responsible for making the

decision whether a team may take out a robot for maintenance. And they observe the correct refill procedure of their field half.

Each referee may call a pause of the game at any time, e.g., if robots must be penalized or disentangled after a collision. Referees may explicitly pause the game to convene and discuss an unclear situation as to avoid hasty decisions. Such pauses shall be short-lived as to follow the competition schedule.

List the usual tasks of a field referee: how to handle mps failures, what to do on mps state broken, how to handle failed scans, controlling ring colors, base station magazines, when to force a maintenance etc

### 4.3 Liability Waiver

Referees cannot be held liable for:

- any kind of injury suffered by a player, official or spectator
- any damage to property of any kind
- any other loss suffered by any individual, club, company, association or other body, which is due or which may be due to any decision, which he may take under the terms of the rules of the game or in respect of the normal procedures required to hold, play and control a match.

### 4.4 Complaint Procedure

Rule issues are not to be discussed during a game. Referee decisions are binding for the game. A team may protest and challenge a game by executing the following complaint procedure. The procedure is also automatically invoked if a referee decides to abort a game for any reason (e.g., field damage, lighting failures, burning robots).

To initiate the complaint procedure, the team leader of the challenging team is to contact a member of the Technical Committee within 10 minutes after the respective game has ended. The member of the Technical Committee then invokes a team leader conference in cooperation with the Organizing Committee. In this conference, the following parties participate: the referees of the game in question, not less than half of all registered team leaders, and the Technical Committee (counseling). The situation shall be resolved by unanimous consent or by vote of the team leaders (majority of team leaders participating in the conference is sufficient).

All teams are reminded that while this is a competition, the league is also about *cooperative* research and evaluation and complaints should be handled in a fair and forthcoming way.

## 5 Game Play

A match is defined by two contesting teams competing within the same identical competition area. Each team consists of a maximum of 3 robots. Each has three phases — for setup, exploration, and production — which are detailed below.

### 5.1 Environment Setup

The physical distribution and alignment of the production machines is dynamic. The field will be organized as described in Section 3.1. The referee box will determine the assignment of the machines

to the zones at the beginning of a game randomly (Section 3.2.2). The color for ring stations will be randomized prior to each match. The processing time of each production step (i.e., per ring color and per cap mounting machine) will be determined in the same way. The target delivery slide will be randomized per order. During the setup phase (cf. Section 5.4)

is this still true or is this referee responsibility?

each team has the responsibility to fill the input magazines on their base station. The elements may only be touched by a robot or by designated persons after the game has started.

## 5.2 Interruptions and Robot Maintenance

During a match and while the robot is active on the field no manual interference or manipulation of the robot in hardware, software, configuration, instructions, or whatsoever, is allowed. Teams may visualize robot data on computers at the field, but existing keyboards must be covered with a sheet of paper in order to assert a fair game without manual interference.

Each team is allowed to maintain each robot twice per game. The first maintenance per robot is free, while the second maintenance for any robot needs to be purchased costing 5 points. If a team has not yet received sufficient points, maintenances can also be purchased on (partial) credit. The remaining points can be deducted from points that are scored later in the game. The score for both exploration- and production-phase cannot become negative due to using additional maintenances.

highlight, that the credit is per phase not per game

Teams have to call upon the referee for *robot maintenance*. The referee should judge the game situation carefully and should allow the robot to be taken out for maintenance,

this is not how it works in practice. Teams often leave a broken robot on the field until it actually obstructs another bot

if the calling team would not have any advantage in the current game situation from taking out the robot. An advantage would be, for instance, to take out a robot, if two robots of the same team are hindering each other. It is up to the discretion of the referee when to allow the robot maintenance.

Another reason for maintenance is a *misbehaving robot*. Several infringements in this rulebook demand that the robot be taken out, e.g., leaving the field (cf. Section 3.1.1).

Because the new generation of Robotinos is relatively heavy and bulky, up to two team members are allowed to remove a robot from the field. Or the robots may be driven out manually by remote control using a joystick, gamepad or similar. Human commands must be mapped directly to motion commands, no autonomous driving is allowed. In both cases (driving out and taking out) the robot must leave the field through the closest opening in the wall unless this would interfere with the game. In that case, the next closest exit may be chosen (referee decides). The robot need to be carried to the insertion area for re-participation.

The repair time may take at most 120 seconds, starting from the moment of driving or taking out the robot. After a robot has been taken out for the first time, the team can perform any repairs to the robot and/or the robot's software. To return the robot into the game, the team asks the referee to place back the robot onto the field. After the referee accepts the motion, the team has 15 seconds quick setup time, which is limited to basic instructions like initial localization or software start-up. The robot may leave the insertion area onto the field (autonomous driving). If the robot is not returned to the field in time, it is disqualified from the ongoing game.

The referee can interrupt the game at any point in time, but should do so rarely as not to interfere with the overall game flow (also cf. Section 5.7).

If a robot needs to be taken out for the third time, either on request or as decided by the referee, it is disqualified from the current game. It may no longer communicate with the still active robots and must be taken out of the competition area.

### 5.3 Game Start

This is not how it was done in 2019, where the setup phase was expected to start before the game start time, iirc

All matches will start at the exact time scheduled by the Organizing Committee with the setup phase (cf. Section 5.4). Once the exploration phase starts, no more interference with the robot is allowed. The robot must react to the referee box game state messages to start the game play autonomously.

### 5.4 Setup Phase

No team member is allowed to enter the competition area prior to or during a match, except in cases of robot maintenance (cf. Section 5.2) or machine refill (cf. Section 5.6.3). All robots which are to participate in the game need to be in the insertion area during setup (not in the game area where the machines are located). The referee box will control the setup period and automatically switch to the exploration phase after 5 minutes.

### 5.5 Exploration Phase

The robots have 3 min to roam the environment and report their 7 MPS to the referee box. The report about an MPS may be split in two parts, the position and type of a machine, and its orientation. Concretely, the referee box expects a *machine identification message* with a tuple consisting of zone, machine name (as encoded in the markers), orientation in degrees. This message may be partially filled to account for the two parts. Please consult the referee box Integrator's Manual [**RefBoxIntManual**] for a detailed definition of the message types. Reports are only accepted for MPS of the respective team over the private encrypted team channel. Only the first information for each MPS is processed and then never updated. The scoring is shown in Table 5(a). A minimum of zero points will be accounted for the exploration phase. The exploration phase ends either after the time has passed or immediately after both teams have each reported their respective set of MPS.

Moving or processing workpieces at an MPS is not allowed during the exploration phase.

### 5.6 Production Phase

With the end of the exploration phase the production phase begins, which lasts 17 min. The referee box publishes information regarding products and machines. This includes machine zones and orientations, and contained colors of ring and cap stations (cf. Section 3.3). The refbox posts orders (cf. Section 5.6.2) which then must be fulfilled by the robot teams. Using production machines requires interaction through communication with the refbox described in Section 3.2.4.

A minimum of zero points will be accounted for the production phase.

#### 5.6.1 Production, Color Complexities, and Additional Bases

The portfolio comprises many different product variants and is categorized by the four available *product complexity* levels shown in Figure 7. The lowest complexity  $C_0$  consists of just a base and a cap

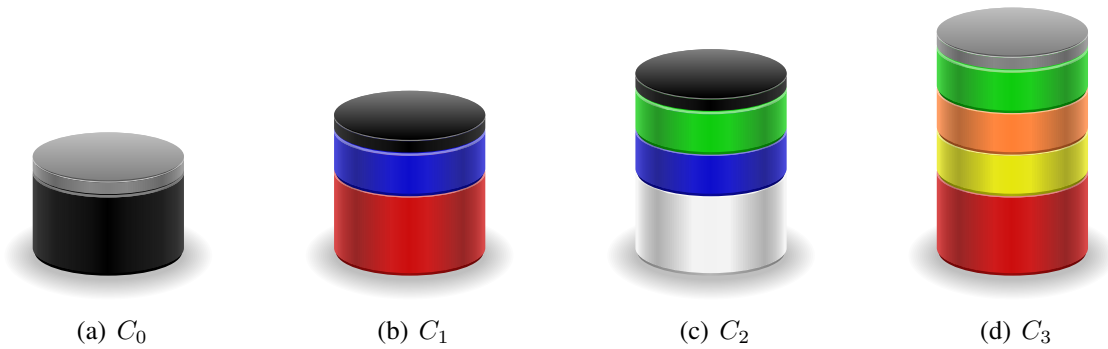

Figure 7: Products are composed of a base element and a cap with zero, one, two, or three intermediate rings representing the product complexity. The complexity level is stated as the number of required intermediate rings. The base element colors are red, black, and silver, the ring colors are blue, green, yellow, and orange, and the cap colors are either gray or black.

and requires to load the CS with the proper cap color and then processing a properly colored base at that machine. The highest complexity  $C_3$  requires a base with three mounted rings and a cap. For a product, the colors of base, rings, and cap as well as the order of the rings are of importance.

Depending on the ring color, the robot may have to deliver one or more *additional bases* to a RS first in order to get a ring. We therefore distinguish *color complexities* as  $CC_0$ ,  $CC_1$ , and  $CC_2$  depending on whether zero, one, or two additional bases are required for a color.

This is not true, the refbox has no such constraint!

The referee box ensures that there will always be some orders for  $C_1$  products where the ring color does not require additional bases, i.e., with color complexity  $CC_0$  — but not necessarily all  $C_1$  orders have this constraint.

### 5.6.2 Production Plan

The referee box will announce orders throughout the game in an incremental fashion. Each order will consist of the product variant to produce, the amount thereof, and a delivery time slot. An order therefore specifies a production chain to be accomplished for fulfillment. Figure 8 shows some example production chains of the four different complexities (cf. Section 5.6.1). The ring colors which require additional bases are randomized per game and announced by the refbox. There will be one color requiring 2 additional bases, one requiring 1 base, and two colors requiring no additional base at all.

This was not enforced in 2019 as far as i know!

Products retrieved from the Storage Station may be used only for  $C_0$  orders with a requested quantity equal to or greater than two. An order can be *competitive* or *non-competitive*. For a competitive order, the scoring differs between first and second delivery; the team that delivers first will get more points than the other team (cf. Section 5.8). For a non-competitive order, each team scores independently of the other team.

In the RefBox we only place 8 regular game orders, the 9th order is competitive

In each game, up to 9 orders will be placed within the regular game. 1 of those orders will be *competitive*, while the remaining orders will be *non-competitive*. In case of overtime, an additional competitive order will be placed.<sup>9</sup> The complexities of orders will be similar for all games within

<sup>9</sup>The numbers can be adjusted during the tournament by the Technical Committee, should this turn out to be necessary.

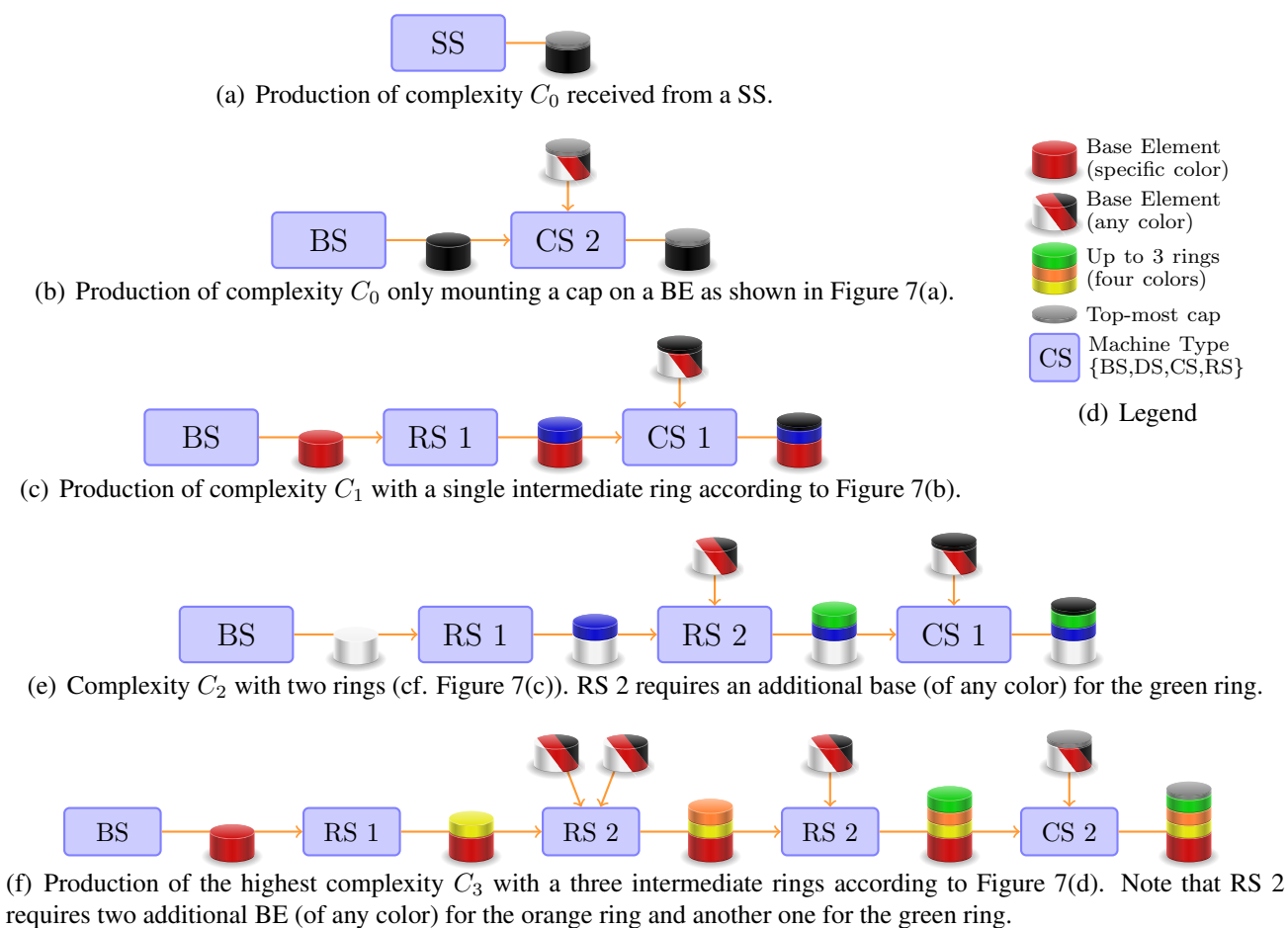

Figure 8: Production Chains of four example products (cf. Figure 7). Blue boxes represent machines. RS 1 mounts yellow and blue, and RS 2 orange and green rings. Mounting an orange ring requires one additional BE (of any color). Similarly two additional BE are required for a yellow ring. Cap stations require a BE (of any color) with a cap of the matching required color. *Note that this is a particular example. The actual production chains and requirements for additional BEs are determined randomly by the referee box for each game.*

a tournament phase. But the actual production chains are randomized. Each order will require one or more products of a specified product type to be delivered. A competitive order always requires exactly one product to be delivered. The product is specified in terms of base color, rings (color and order), cap color, and possible delivery gate. The delivery time slot will have a randomized start time. The duration will be randomized between 30 to 180 seconds. The end time shall be within the game time. There is not necessarily an open order for a particular product at a specific time, or any order at all.

Not how it is done in the RefBox: the standing orders are posted in the beginning.

The first order will be posted within the first 120 seconds of the game (but not necessarily at the beginning of the game). Orders for the products of complexity  $C_2$  or  $C_3$  will not

does this mean delivery begin ord posting time? If it means the latter, then this is not done in the RefBox

begin in the first 300 seconds. An order will be announced before the delivery time slots starts. For  $C_0$  products the lead time ahead of the start of the time window is 60 to 120 seconds, for  $C_1$  it is

120 to 300 seconds, and for  $C_2$  and  $C_3$  orders the time is between 300 and 600 seconds.

I guess these are the  $C_2$  and  $C_3$  in the RefBox, however they are always announced in the beginning, it seems

Two early orders will be posted that are announced in the first third of the game with a delivery time window in the last third. For each of the complexities  $C_0$  and  $C_1$  a standing order for a single product will be placed at the beginning of the production phase, which can be fulfilled at any time during the game. Competitive orders are always for products of complexity  $C_0$ . A competitive order cannot be a standing order.

Teams playing on the field at the same time will get the same production plan. However, each game will use a new randomized order schedule.

The multi-staged production processes can be repeated as long as enough material can be provided to complete the cycle (also cf. Section 5.6.3). The different machine types are specified in Section 3.2.

### 5.6.3 Machine Refill

This was not done in 2019, referees restocked BS and cared about rings

The teams are responsible for restocking all materials (base elements, rings, prepared caps on shelves, and  $C_0$  in the SS) before and during matches. Each team has to designate one team-member as a “replenisher” who must be specified to the corresponding “field half/team” referee ahead of each game. Only this team member will be allowed to access the field area and only in case of a recent refill procedure. The replenisher must not obstruct other robots and should interfere as little as possible. The machines can only be refilled when a magazine or shelf is empty. In this case the field-operator may enter the competition-area without asking the referee. Shelves have to be (re-)filled in all three reachable slots. The replenisher may restock only caps if transparent base elements have been put back to the shelf, once no cap is remaining on this shelf.

The teams are partly free to choose their assembly and placement of products. For example, teams can fill any number of bases into a BS or are free to choose the color of caps for a CS, however teams are only allowed to fill the CS if the whole shelf is empty and then it has to be filled completely. The color assignment of bases on the BS and SS must be obeyed, as otherwise they will deliver the wrong bases.

## 5.7 Special Events during a Match

Any referee can interrupt the match at any time. After the game is paused, all robots have 3 seconds to stop any movement. Robots that do not stop within the time limit will be treated in the same way as misbehaving robots (cf. Section 5.2). The match time will be paused during the interruption.

### 5.7.1 Scheduled Machine Downtime

The refbox will take down machines randomly out of the pool containing the RS and CS. It will do so at random points of time and with the same conditions for both teams, i.e., affecting the same machines for both teams. There will be 2 of such triggered events during a match. The machines affected will remain out of order for 30 to 60 seconds. Every machine can only be forced out of order once per match. If a machine turns offline during processing a product it will afterwards resume the process (extending the overall processing time by the down time). The downtime is indicated by a steady red light. Base elements fed into the machine while out-of-order are

not the case for ring station slides, the ring counter is increased instantly if i am not mistaken. This is probably not relevant

accepted when the machine gets back online, with the same constraints mentioned in Section 3.2.4.

### 5.7.2 Broken Machine Downtime

If a machine is improperly instructed or used, or a reset message has been sent, the machine will go into a failure state. The machine cannot be used for 30 seconds and until repaired. That is, if damage was inflicted on the machine or the referee needs longer to repair the machine the game continues and the machine will be offline for a longer time. Any production that was running will be aborted and any product which was being processed is no longer available and will be removed by the referee. Any additional bases or caps buffered at the machine will be void and the points gained removed. For storage stations, no slot is refilled, the load status remains exactly as before the broken state. The downtime is indicated by a flashing red light.

## 5.8 Task Fulfillment and Scoring

During the production phase, points are awarded for intermediate production steps and final delivery of goods according to Table 5.

This section is confusing, i would suggest to separate the 2017 scoring scheme from the barcode scheme

#### Proposed Change:

If barcode scanners are used during during a game, then the following scoring rules apply: Points for production steps associated with an order are awarded as soon as completed (when the barcode scanner at the output of the used station reports the scanning result). Points are only awarded if there is yet an order for which the performed step is required and which has not yet expired (the end of the order time window has not yet passed) and for which the step has not been performed for as often as products have been requested. For example, consider a  $C_1$  order with a single ring of which two products have been requested. When the appropriate ring of that  $C_1$  product is mounted, the appropriate points (for finishing a  $C_1$  pre-cap) are awarded if and only if the end time of the delivery window of that order has not passed and the step has not been completed more than two times (including the just performed step). Therefore, only production steps which can be determined to belong to an upcoming (and announced) or on-going order can be awarded. Performing a step for a later order which has not yet been announced cannot be awarded.

If the barcode scanners are not used, the old scoring scheme from 2017 applies: All points related to a product, including the points for finishing intermediate step like mounting the last ring on higher complexity products, are awarded on delivery only. Products, which are not delivered, do not score. That includes half-finished products at the end of the game in particular. Points for intermediate steps are also awarded for later deliveries, but not for wrong deliveries.

#### Old Text:

Points for production steps are awarded as soon as completed.<sup>10</sup> Points are only awarded if there

---

<sup>10</sup>This relies on the bar code system described in Section 3.3 which will be introduced in 2019. Should this be delayed or proof infeasible, the mode of operation in 2017 will be used: all points related to a product, including the points for finishing intermediate step like mounting the last ring on higher complexity products, are awarded on delivery only. Products, which are not delivered, do not score. That includes half-finished products at the end of the game in particular. Production points are also awarded for later deliveries, that is, points for steps like mounting the cap are awarded in full for as long as there was or is an order active for that specific product if there are still items in the order remaining, i.e., not



is yet an order for which the performed step is required and which has not yet expired (the end of the order time window has not yet passed) and for which the step has not been performed for as often as products have been requested. For example, consider a  $C_1$  order with a single ring of which two products have been requested. When the appropriate ring of that  $C_1$  product is mounted, the appropriate points (for finishing a  $C_1$  pre-cap) are awarded if and only if the end time of the delivery window of that order has not passed and the step has not been completed more than two times (including the just performed step). Therefore, only production steps which can be determined to belong to an upcoming (and announced) or on-going order can be awarded. Performing a step for a later order which has not yet been announced cannot be awarded.

For a competitive order, the same scoring scheme for in-time, delayed, and late delivery applies, with additional points for a successful first delivery and a point deduction for the second delivery (cf. Table 5). The deduction may not exceed the points given for the delivery.<sup>11</sup> Points for production steps are given in the same way as for non-competitive orders. In particular, production points are also given if a team delivers the product after the other team.

There is a special case regarding the Storage Station. Retrieving a workpiece has a cost (see Table 5). The cost is subtracted as soon as the workpiece is ready for retrieval on the SS. However, exploration points gained during the exploration will not be used for this. If the team has not yet received sufficient points, workpieces can be “purchased on (partial) credit”. Points that were missing upon preparation will be subtracted later from points scored.

Rework scoring table: Clarify that last ring points are additional to regular mount ring points, simplify delivery scoring or at least clarify that the cases are completely distinct. Also note that early delivery gives no points at all!!! (or fix it in refbox)

## 5.9 Obstruction Penalty

move to referee section

As the Logistics League follows the idea of having both active teams compete alongside each other, instead of directly against each other, we punish intentional obstruction of the opposing team.

This applies in particular to the input and output area in front of any MPS. All robots are allowed to enter this space, but robots must not obstruct opposing robots which intend to approach their MPS. Concretely, that robot must give way and release an approachable path to the MPS within a time window of 10 seconds. If a robot cannot follow this rule, a pushing foul will be called according to Section 5.10.

Furthermore, teams are penalized for obstruction according to Table 5 when delivering a workpiece to a machine of the opposing team. In this case, the workpiece becomes junk and cannot be used afterwards.

## 5.10 Pushing Rules

move to referee section

With multiple teams on the field at the same time, robots must implement ways for collision avoidance. At the same time, they shall not interfere with the goods of the other team. The case where a robot of one team bumps into or moves a robot of another team we call “pushing”.

---

the full amount of ordered products has been delivered.

<sup>11</sup>As an example, if a team delivers late and scores only 5 points for the delivery, only 5 points will be deducted.

Report type	Description	Points
Zone/Orientation	Correctly determine a machine zone and the rotation of your team and report it successfully to the refbox	+2
Type	only machine zone reported	+1
	Machine zone reported correctly but orientation wrongly (1 – 1 = 0)	0
	wrongly reported machine zone (orientation irrelevant)	-1
Round Total	A maximum of 14 points can be achieved by correctly reporting all 7 production machines. A minimum of 0 points is awarded.	0 to 14

(a) Scoring scheme for the exploration phase

Sub-task	Production Phase	Points
Additional base	Feed an additional base into a ring station	+2
Finish $CC_0$ step	Finish the work order for a color requiring no additional base	+5
Finish $CC_1$ step	Finish the work order for a color requiring one additional base	+10
Finish $CC_2$ step	Finish the work order for a color requiring two additional bases	+20
Finish $C_1$ pre-cap	Mount the last ring of a $C_1$ product	+10
Finish $C_2$ pre-cap	Mount the last ring of a $C_2$ product	+30
Finish $C_3$ pre-cap	Mount the last ring of a $C_3$ product	+80
Mount cap	Mount the cap on a product	+10
Retrieve cap	Buffer a cap into a cap station	+2
Retrieve from SS	A workpiece has been requested from storage and is ready for retrieval	-10
Delivery	Deliver one of the final product variants to the designated loading zone at the time specified in the order	+20
Delayed Delivery	An order delivered within 10 seconds after an order is awarded a reduced score. For delivery time slot end $T_e$ and actual delivery time $T_d$ in seconds the reduced score is given by $\lfloor 15 - \lfloor T_d - T_e \rfloor * 1.5 + 5 \rfloor$	up to +20
Late Delivery	An order delivered after 10 seconds	+5
Wrong delivery	Deliver one of the final product variants to the designated loading zone out of the requested time range or after all products requested in the period have already been delivered	+1
False delivery	Deliver an intermediate product	0
1st competitive delivery	Points for the first delivery for a competitive order. The score is given in addition to the points for the regular delivery.	+10
2nd competitive delivery	Point deduction for the second delivery for a competitive order. The points are deducted from the delivery points, the total cannot be less than 0 points.	-10
Obstruction	Deliver a workpiece to a machine of the opposing team	-20
Round Total	A minimum of 0 points is awarded.	$\geq 0$

(b) Scoring scheme for the production phase

Task	Game Commentary	Points
Accepted Commentary	Commentate at least one half of the game continuously on microphone in English (or the local language of the venue) to the public	+10

(c) Scoring scheme for game commentary

Table 5: Scoring Schemes

The following rules shall be obeyed by the robots and provide the guidelines for referees to call for improper behavior of a robot due to pushing.

1. Pushing occurs only between robots of different teams.
2. Robots must drive such that they try to avoid physical contact with robots from the opposing team. However, physical contact per se does not represent an offense.
3. All robots should be equipped with appropriate sensors to detect situations of physical contact with other robots (direct pushing situations).
4. If physical contact with other robots cannot be avoided, it must be soft, i.e., at slow speed and with as small physical impact as possible, in order to avoid damage to itself and other robots. Robots moving at high speed must significantly decelerate before a collision occurs with another robot.
5. **This just means the referee should pause**  
**If a destruction collision is immediate and the robots do not react, the referee should use the refbox to send a stop command to all robots. Every team has to react to the stop command by immediately stopping their robots.**
6. Whenever a robot produces direct physical contact with another robot while moving, it must stop movement immediately in that direction (and choose a new direction for movement).
7. If pushing occurs between a moving and a standing robot, the moving robot causes the pushing situation and is responsible for resolving it. If it is not able to do so, a pushing foul will be called.
8. If pushing occurs between two moving robots, both robots are responsible for resolving the pushing situation. If one robot continues pushing by moving in its initial direction, while the other robot is recognizably reacting and trying to take another direction, the foul will be called on the pushing robot.
9. If two robots encounter physical contact and cannot resolve the situation because they get entangled, the referee may issue a pushing foul on both robots.
10. If, in the opinion of the referee, physical contact between two robots is not soft, or if one or both of the robots do not change direction after encountering physical contact, a pushing foul will be called.
11. When a pushing foul is detected the responsible team has to use up their restart for the stuck robot to start at the insertion zone again. The other team can decide within 10 seconds to restart their involved robot in the insertion zone without it counting as a penalty restart.
12. Moving a workpiece of the opposing team at their MPS is a pushing foul. The referee will move the workpiece back to its original position.
13. Intentional obstruction of the opposing team is a pushing foul, as described in Section 5.9.
14. If a robot is restarted or called to maintenance, loses his workpiece during collision avoidance or in case of a collision, the workpiece will not be replaced and is removed by the referee.
15. The league reserves its right to disqualify clearly malicious teams.

## 6 Tournament

The tournament is organized in a main competition and three technical challenges. Teams can decide to participate in any of those.

### 6.1 Tournament Phases

There will be three stages in the main competition, a round-robin phase for all participating teams, playoffs for the best four teams from the round-robin phase, and the finals. The best two teams of the playoffs play the grand finale to decide which team will become the next Logistics League champion, whereas the other two teams compete in the small final for the third place.

#### 6.1.1 Round-Robin phase

The first stage is a group phase and will be played as a round-robin. The teams will receive the true points they scored during the competition. The points will be accumulated in this phase and the teams will be ranked according to the accumulated points in descending order. Depending on this order, only the first 6 teams are qualified for the Playoffs.

#### 6.1.2 Playoffs

The play-offs can be played in one out of two modes, depending on the number of qualified teams.

**6 Qualified Teams.** Qualified teams will be divided into two groups of three teams each. The first group will be composed of the teams that ranked first, fourth, and fifth in the Round-Robin phase respectively. The second group contains the teams that ranked second, third, and sixth. Within each group, each team plays against all other teams (round-robin).

**Less than 6 Qualified Teams.** All qualified for the Playoffs are added to a single group and play in round-robin fashion each team against all other teams.

#### Scoring Scheme.

Move to beginning of playoff section

During playoffs, the scoring scheme will be different from the Round-Robin and is based on a ranking score per won games. As each team in this phase directly competes with an opposing team, a ranking score will be determined as follows. In each *game*, the winning team gets 3 ranking points, the losing team gets 0. A team wins if it achieves more points in the game than the other team (cf. Sections 5.5 and 5.6). In the case of a non-zero draw, see Section 6.1.4 for overtime. If, after overtime, a draw is not resolved, both teams get 1 ranking point. If both teams end with a zero score, each team gets 0 ranking points. Points awarded for commentary are not considered in this decision.

**Ranking.** The *overall ranking* is determined by the ranking score of teams, highest first. If two teams have the same score, the overall total in-game points are summarized and the team with more game points ranks higher. If there still is a draw, the direct comparison of the games of the two teams is used to break the tie. If this still is unsuccessful, a coin toss determines the higher ranked team.

### 6.1.3 Finals

The best teams of the two playoff groups (or the two best teams in case of one group) will advance to the grand finale, the remaining two teams will compete in the small finals for the third place. The team that scores more points after the regular game time wins. If there is no winner after the regular time, refer to Section Section 6.1.4. If after this there is still no winner, a coin toss will decide.

The detailed seeding will be created at the event. Although the idea is to allow each participant to challenge each other team, the league can be adjusted to meet time requirements.

### 6.1.4 Overtime

Starting with the play-offs phase of the tournament the game must be won by one of the teams by a higher score. If after the regular game time there is a draw, the game will automatically and without interruption be extended by 5 more minutes, unless both teams scored zero points (points awarded for commentary are not considered in this decision). If after five minutes there is still no winner, the team scoring the first points during the extension will win.

## 6.2 Game Commentary

In addition to scoring in the exploration and the production phase, points are also awarded if a team provides an commentary on microphone to the public throughout the game as stated in Table 5. The commentary should communicate the overall problems to be solved within this league, the actual events taking place, but also give an insight on the own team and how they solved certain tasks. It does neither have to be perfect, nor to be a flawless stream of information. The commentary should be continuous, but short pauses are acceptable. At the end of the game the referees decide if the commentary duties were met. If both teams are willing to commentate on the game, the game time is shared according to the team specification (e.g., team 1 commentates the first half, team 2 the second half). However, the teams can also make custom arrangements to split the overall time.

## 6.3 Penalties

The catalog in Table 6 represents the decision basis for the referees not being exhaustive or binding.

move to referee section

## 6.4 Technical Challenges

Within the league, the technical advances should be documented from year to year. Therefore, the Technical Challenge is introduced. Each team should prepare for participating in any number of the following tasks. However, participation has no influence on the normal game results, but the winner will be awarded by a certificate.

### 6.4.1 Markerless Machine Recognition and Production

Currently, machines have markers that allows for recognizing their respective types and relative position. The idea of this challenge is, to remove the markers and still be able to recognize the type of a machine and feed a base element onto the conveyor belt.

For this challenge, the markers will be removed or otherwise hidden. Any sensor feedback is allowed to recognize the machine, but no kind of markers or other indicators is allowed to be added to the machine or the environment. The general idea is to test this as an advancement of the league for future events. Distances between robots and the machine are measured as the shortest distance from MPS trolley to robot base on the ground. The maximum achievable score in this challenge is 40 points — up to 10 for the recognition and production parts each, up to 10 for the explanation and methodologies, and up to 10 for the public release of the source code.

**Recognition** The refbox will randomly select four zones and machine types. The machines are placed in the center of the respective zones. The robot must approach the machines one after another and use only sensors mounted on the robot to recognize the physical type of the machine. The machines can be of any type. There is a time limit of 2 min for the recognition task in which machines can be recognized.

The recognition part scores up to 20 points — 5 points for each machine. Of these 5 points, 2 points are awarded for proper approach (robot standing at the input or output side of the machine facing towards the machine with a distance of no more than 0.5 m) and 3 points for correct recognition.

Issue	Sanction
Premature movement	No robot is allowed to move until the referee announced the start of the match. The faulty robot will be grounded for 2 minutes.
Damaging factory equipment	Theoretical damage to the real factory equipment as a result of collisions and negligent actions. This behavior will be punished as a minor rule break.
Not showing up	A team not showing up at all. The team will be removed from the tournament unless the team leader can provide a sincere explanation.
Manual Interference	A manual interference of a team, i.e., touching a robot without the referee's permission, during the game will be punished as a major rule break.
Breaking a minor rule	A rule infringement with minor impact on the team performance or competition mechanics. Upon decision of the referee, 25 % of the scored points of the team at the time of the infringement will be deducted, at least 1 point.
Breaking a major rule	A rule infringement with considerable impact on the team performance or competition mechanics. Upon decision of the referee, 50 % of the scored points of the team at the time of the infringement will be deducted, at least 5 points.
Arguing with the referee	There will be no discussions during a match. Each team can make a motion to protest a certain match and its result which will be dealt with after the match. There will be a warning. Continued disregard will result in a time punishment to the team's current or next match.
Disregarding rules of conduct	Following the rules of conduct should be self-explanatory. Upon disregard, the referee will impose sanctions ranged from time punishments to the team's complete removal from the tournament.

Table 6: Infringements

The recognition must be provided clearly visible on a screen or by text-to-speech output.

**Production** The refbox will randomly select a CS machine. The machine will be pre-filled with a cap. The robot must then retrieve a base element without cap from the shelf of the CS (at least one spot will be filled with such a base element), feed it into the cap station, and retrieve the finished product on the output side.

The production part scores up to 10 points. 3 points are awarded for a proper approach (robot standing at the input or output side of the machine facing towards the machine with a distance of no more than 0.25 m, note that the distance is shorter than for the recognition part). Another 4 points are awarded for properly feeding the base into the machine and the final 3 points are awarded for successfully retrieving the finished product (moving with the product to a minimum distance of 0.5 m of the machine).

### Explanation and Methodology

Not enforced at all at the moment

The teams need to explain their used methods and techniques. The jury of team leaders each gives scores from 0 (insufficient or no explanation) to 10 (excellent explanation and useful methods). The rounded up average of these points is added. Teams which have released the source code to their approach on the web score up to 10 points. The jury again vote points depending on the documentation and wealth of the implementation from 0 (no source code provided) to 10 (source code provided as readily usable package including all necessary dependencies). If a package is only usable within a non-disclosed software framework, the release cannot score more than five points.

### 6.4.2 Playing in Simulation

There is no simulation league at the moment at RoboCup, therefore this does not need to be part of the rulebook

The challenge is to play the production phase of an RCLL game, based on the publicly released Gazebo-based simulation [llsf-sim-rc2014-2014]. The simulation software<sup>12</sup> including technical documentation is publicly available on Github.<sup>13</sup>

The simulation uses Gazebo and the exact same referee box to simulate the environment reactions similar to the real game. We envision this simulation to be a basis for a simulation RCLL sub-league to attract a wider range of participants, but also to ease entering the robot competition.

There is a new Planning Competition for Logistics Robots in Simulation [LogRobComp2016] that is held at the International Conference on Automated Planning and Scheduling (ICAPS). The technical challenge game will be played according to the same rules and regulations of the ICAPS competition [LogRobComp-Rules-2017]. The rules and regulations, the reference USB stick image, and a video tutorial is available at <http://www.robocup-logistics.org/sim-comp>.

**The Game** This challenge will be played following the rules of 2016, the most notable difference is that there is no Storage Station. After a short setup period of 60 sec, the production phase will be started immediately. The ground truth for the machine positions will be provided.<sup>14</sup> Please refer to the ICAPS competition manual for the available interfaces.

<sup>12</sup> <https://www.fawkesrobotics.org/projects/rc11-sim/>

<sup>13</sup> <https://github.com/robocup-logistics/gazebo-rc11>

<sup>14</sup> This means that some of the major changes in 2017, regarding the Exploration Phase, are irrelevant for the simulation challenge. This is done to align closely with the ICAPS competition.

**Hardware Setup** We use the same infrastructure as is used in the ICAPS competition. It is based on a Kubernetes infrastructure. The competition cluster setup is available and documented at <https://github.com/timn/rc11-sim-cluster>. The USB stick image provided on the competition website can be used for local testing.

**Simulation Interfaces** We will follow the ICAPS competition's setup and will provide two principal interfaces: one based on Fawkes, and another based on ROS. Please see the ICAPS competition's rules and regulations for the details.

**Robot Models and Plugins** The simulation will be run with the standard set of models and plugins of the Carologistics RoboCup team based on the 2016 source code release.<sup>15</sup> No custom Gazebo plugins or models may be loaded or used by the competing teams. Since no physical simulation of workpiece handling is done and the base regarding locomotion is the same, there should be no issues for the teams to implement the flow of the game. However, teams must make sure that the standard set of sensors provided is sufficient.

**Competition Area** The competition area can be expected to be similar to Figure 1, however, the MPS locations will be randomized as in the real game.

**Abstraction Level** Teams need to utilize their robot sensors to perceive the environment. There will be no available ground truth published to the robots by the simulation software. That is, robots need to localize and recognize the machines as well as localize themselves via sensors attached to the robot.

### 6.4.3 Open Challenge

Each team will be given

this was significantly longer

**5 minutes** to showcase their robot team, e.g., show some new robotics developments. This may involve any task as long as it is performed with at most three Robotino robots within the competition area. For the time of the free challenge, any software or hardware modification is allowed, even though otherwise disallowed in the regular competition. This may be used to motivate ideas for future developments of the league and to highlight particular advances in the system of the presenting team.

The team leaders of non-presenting team will judge the performance and rate it with points between 0–10. The team with the highest sum of points will win this challenge. The other teams are ranked in decreasing point order.

### 6.4.4 Conducting the Challenges

Does this include the open challenge? Clarify this

The technical challenges are conducted in the following way. The team leaders of each participating team agree on a date and time during the tournament for the Technical Challenge in their first team leader meeting. For each type of challenge, a time slot is assigned, in which teams can participate once in the challenge. Each team can register for any of the challenges. All team leaders have to be present at the time of the challenge to judge the other teams. The OC is responsible to conduct the Technical Challenge and can appoint team leaders as support. Each challenge will have a separate

<sup>15</sup> <https://www.fawkesrobotics.org/p/rc112016-release/>



ranking. In each ranking, the team on the last rank will receive 0 points, the last-but-one ranked team will receive 1 point etc. The points for each ranking will be added and the team with the most points accrued over all challenges will be awarded with the Logistic Leagues Technical Challenge Award.

## 7 The Robotino System

All participants have to design their competition Robotinos within the following specifications. For a detailed technical description of the basic hardware, refer to the Appendix A. Robotino 2 is still allowed, however, we strongly recommend using the Robotino 3 as the robot hardware platform from this year on.

Any kind of sensors can be changed or added to the Robotino platform. However, it is not possible to implement sensors that require modifications outside the Robotino area (e.g., Northstar, indoor GPS). There must be no changes to the controller or mechanical system. The robots peripherals must not exceed the maximum total height of 1.1 m including the tower and the table on top. Additional hardware (sensors, computing equipment, etc.) must be within a circle of a diameter of 0.55 m or centered at the robot's rotational center-point. Additional hardware may only occupy up to 25% of this additional 0.05 m wide ring around the robot. The only additional actuator allowed is one gripping device for workpieces which can be the original or a modified one. In the resting position and while driving it also must not exceed the robot diameter by more than this 5cm, including workpiece. In front of a machine and during a production process, the gripper may be extended up to 30cm. But it is only allowed to reach a maximum of 15cm into the machine area. The gripper is allowed to transport one workpiece at a time. And it must release the workpiece for safety whenever the referee wants to take out it.

It is allowed to install additional computing power on the Robotino. This may either be in form of a notebook/laptop device or any other computing device that suits the size requirement of the Robotino competition system. Furthermore, it is allowed to communicate with an additional computing device off-field. This device may be used for team coordination and/or other purposes. However, communication among the robots and the off-field device is not guaranteed during the competition.

### 7.1 Markings

This is not enforced

All field robots must be assigned a single unique number out of the set  $\{1, 2, 3\}$ . The number must be written on the robot in one or more places and clearly visible from all directions, e.g., printed adhesive labels placed on top or the sides of the robot. The number must be the same as is announced in the beacon signal to the referee box (cf. Section 8.2).

For audiences and observers to distinguish both teams, all robots must wear their respective unique colored label which is either cyan or magenta. The Velcro will be provided and is suggested to be placed on the tower's side of each robot, the actual color-coded rings are then dynamically divided among the playing teams.

## 8 Communication

Robots have to operate autonomously, that is, without any human interference during the game. Communication among robots and to off-board computing units is allowed only using wifi (cf. Section 8.7). Communication is not guaranteed and may be unavailable during parts of the game. Interruptions

must be expected and are no reason to pause or abort a game, even if they endure for long periods of the game.

## 8.1 Bandwidth Allocation

No minimum bandwidth is guaranteed. The amount of communicated data over the wifi connection shall not exceed 2 Mbit/s. Even though the lower layers could provide for more bandwidth, the overall available frequency spectrum and wifi channels have to be shared, not only within our own league. Generally, a conservative use of bandwidth resources is advised. Should a frequently or endured exceedance of the bandwidth limit become known, or if the overall bandwidth limit must be reduced due to outer circumstances, the TC can monitor the network traffic and demand reduction in communicated data as necessary.

## 8.2 Referee Box (refbox)

The referee box (refbox) [**RCI-RefBox**] is a software system that runs on a system provided by the Organizing Committee. It controls the overall game, monitors feedback from the robots, and awards points. It is instructed by an assisting human referee and keeps a log of all relevant game events. The final game report will be produced by the referee box. While we strive for a maximum of automation of this control task, we rely on the human referee for final judgment, in particular for border or under-specified cases, and will provide the largest set of override abilities feasible.

The refbox is the single point of instruction for robots during the game. After game setup has finished, game state information and orders are announced by the refbox. Commands must be acknowledged. In certain situations (for example during the exploration phase) for successful and true communication with the refbox points are awarded. The aim is to reduce human interference year by year to a minimum as to exhibit the widest autonomy during the game possible. Ultimately, the refbox should be able to fully control the game by itself, transforming all participants, team members, and visitors alike into pure spectators of the game, sometimes providing maintenance and crisis intervention when necessary.

The communication from the refbox to the robot is a datagram-oriented broadcast protocol based on Google protocol buffers<sup>16</sup> (protobuf). The protocol definition and technical parameters are described in detail in the RoboCup Logistics League Referee Box Integrator's Manual [**RefBoxIntManual**]

## 8.3 Remote Control

Remote operation or instruction of any kind of the robots is forbidden at all times during a game. The only allowed interaction is for the start-up (cf. Section 5.3). Any failure to comply with this rule will lead to immediate disqualification of the infringing team.

## 8.4 Monitoring

*Passive* monitoring, i.e., receive-only communication from a base station of the robots' performance is allowed. However, the overall bandwidth limit may not be exceeded. If the referee has any reason to believe that a monitoring application might be used for instruction, he can demand the shutdown of the monitoring software (also refer to previous section on Remote Control).

---

<sup>16</sup>Available at <https://code.google.com/p/protobuf/>

## **8.5 Inter-robot Communication**

Robots currently active on the field can freely exchange any information that supports a coordinated team play. Robots not actively participating in the game, for example because they have been irrevocably removed from the current game, may not communicate with the other robots. It is forbidden to communicate with any sensors that are not physically attached to the robot, including, for example, but not limited to a camera aside the field. Likewise any off-robot actuator is forbidden.

## **8.6 Communication Eavesdropping and Interference**

Communication of another team may neither be eavesdropped on nor be interfered with. Teams not currently active shall disconnect from the field access points.

Monitoring of bandwidth used or of possible misbehavior may only be performed by members of the TC or an appointed delegate. Any indication of misbehavior will be discussed by the team leader convention and may result in penalties or disqualification from the tournament.

## **8.7 Wifi Regulations**

In order to provide the optimal possible solution for wireless communication during the event, all teams are required to use the 5 GHz wifi equipment. They are furthermore required to connect their Robotinos wifi unit to the access point provided. All teams can also rely on wifi clients supplied by Festo but are not required to. A detailed description concerning the infrastructure can be found in Appendix A.1.7.

# A Engineering Reference

## A.1 The Mobile Robot System Robotino 3

The mobile robot system Robotino is a platform with open mechanical and electrical interfaces for the integration of additional devices like sensors or motors. By default power is supplied via two exchangeable 12 V lead gel batteries which permit a running time of up to two hours. Robotino is driven by 3 independent, omni-directional drive units. They are mounted at an angle of  $120^\circ$  to each other. The three omni-directional drive units of Robotino defines it as being holonomic, meaning that the controllable degrees of freedom equals the total degrees of freedom of the robot. The drive units are integrated in a sturdy, laser welded steel chassis. The chassis is protected by a rubber bumper with integrated switching sensor.

### A.1.1 Robot Dimensions (w/o extension tower)

- **Diameter:** 450 mm
- **Height including housing:** 290 mm
- **Overall weight:** approx. 22.5 kg
- **Maximal payload:** about 30 kg

### A.1.2 Drive Unit

- **3× omni-directional wheels:** 120 mm
- **Fed by DC three motors:** 3600 rpm
- **Gear transmission ratio 32:1** 22.5 kg



(a) Festo Robotino 2



(b) Festo Robotino 3

Figure 9: Robotino 2 and Robotino 3 without assembly tower

The motor speed will be controlled via a PID controller implemented on a Atmel microprocessor of the controller board of Robotino.

### **A.1.3 Sensors**

Robotino is equipped with 9 vertical mounted infrared distance measuring sensors which are mounted in the chassis at an angle of  $40^\circ$  to one another. Robotino can scrutinize all surrounding areas for objects with these sensors. Each of the sensors can be queried individually via the controller board. Obstacles can thus be avoided, clearances can be maintained and bearings can be taken on a selected target. The sensors are capable of accurate or relative distance measurements to objects at distances of 4 cm to 30 cm. Sensor connection is especially simple including just one analogue output signal and supply power. The sensors' evaluation electronics determines distance and read it out as an analogue signal. The anti-collision sensor is comprised of a switching strip which is secured around the entire circumference of the chassis. A reliably recognizable signal is thus transmitted to the controller unit. Collisions with objects at any point on the housing are detected and, for example, Robotino is brought to a standstill. The inductive proximity sensor is supplied as an additional component. It serves to detect metallic objects on the floor.

The default webcam camera is plugged in via USB and is capable of full HD 1080p video with auto light correction and two built in microphones for stereo sound with noise-canceling.

### **A.1.4 Controller Board**

Robotino is powered by an exchangeable Embedded PC-COM Express layout combined with a custom made sensor board.

#### **Embedded PC according to COM Express specification**

- Embedded Intel Core i5, 2.4 GHz, Dual-Core
- 8 GB RAM
- 64 GB SSD (exchangeable)
- Operating system: Linux Ubuntu 12.04 (64-bit)

#### **Embedded PC interfaces**

- 1 × Ethernet
- 6 × USB 2.0
- 2 × PCI Express expansion slot
- Wireless LAN according to 802.11b/g, client or access point mode
- 2 × RS232
- 1 × Parallel port and 1 × VGA port
- Wireless LAN Access Point following the standards 802.11b/g.
- The access point supports client mode, optional WPA2 encryption.

## Motor control

- micro-controller with 32-bit microprocessor and separated Ethernet interface
- Including 1 × additional motor output and encoder connector
- 8 × analog inputs from 0 V to 10 V (50 Hz)
- 8 × digital inputs/outputs with 24 V, short circuit proof and overload protected

### A.1.5 Power supply

- 2 × 12 V lead-fleece rechargeable batteries with 9.5 Ah capacity each
- Operating time (default batteries): up to 4 h
- Power supply for additional components: 13 × 24 V, 13 × GND
- Internal charger for lead-gel and NiMH rechargeable batteries
- 24 V power supply for charging batteries

### A.1.6 Software

Pre-installed is Ubuntu Linux 12.04 LTS operating system, 16.04 LTS available. The main part of the controller is the Robotino server, a real time Linux application. It controls the drive units and provides interfaces to communicate with external PC applications via wifi. Also provided: API 2.0 with libraries which allow you to create applications for Robotino in numerous programming languages:

- C++ and C
- C#
- .net and JAVA
- MatLab and Simulink
- Labview
- Robot Operating System (ROS)
- Microsoft Robotics Developer Studio

You may find a lot of examples concerning using the different API's in the public OpenRobotino forum at <http://www.openrobotino.org>.

**Web interface** HTML5-based user interface provided by web server running on an embedded PC for setup and configuration using smartphone, tablet or PC/notebook User interface supporting program management, manual control, network setup, status display and options Help system: online manual for getting started, details on all components and introduction into programming

**Robotino View** For a quick start or Hardware testing there is proprietary drag and drop Software Robotino View. Graphical programming environment for external PC running on Windows XP, Vista, Windows 7 or Windows 8.

- Main program using sequential function chart according to IEC 61131
- Reusable subprograms based on function blocks
- Library for function blocks and devices
- Global variables for communication between subprograms
- Program interpreter to run programs on Embedded PC autonomously

Additional information as well as accessories can be obtained through <http://www.robocup-logistics.org/links/festo-robotino-3>.

### A.1.7 Wifi equipment

Festo AP	LANCOM L-322agn
Transfer rate	Up to 108 Mbit s <sup>-1</sup>
Data link protocol	802.11 a/g/n
Frequency	5.0 GHz
League channel	40
Allowed channels (with restrictions) <sup>a</sup>	100, 104, 108, 112, 116, 132, 140
Channel width	20 MHz
IP-distribution	172.26.200.xxx for LAN clients (DHCP) 172.26.101.xxx for the Robotino devices 172.26.1.xxx for Robotinos
Subnet Mask	255.255.0.0
Encryption	Unsecured
SSID	Separated for both teams: RobotinoEvent.1 RobotinoEvent.2
Festo Clients	3COM WL-560
Power Supply	Clients: 12 V, 1 A, Most Laptops cannot power them via USB!
Connector	Ethernet

Table 7: Technical specification of the wifi equipment

<sup>a</sup>Please refer to the official radio policy for details: [https://rr1.robocup.org/wp-content/uploads/2019/01/RoboCup\\_2019\\_Radio\\_Policy\\_2018-12-24.pdf](https://rr1.robocup.org/wp-content/uploads/2019/01/RoboCup_2019_Radio_Policy_2018-12-24.pdf)