JN-MPPT-MINI/AL/BL/CL Buck Series Solar Charge Controller

User Manual



Contents





Contents.....	- 0 -
I. Safety instructions.....	- 2 -
1.1 Safety signs.....	- 2 -
1.2 Safety instructions.....	- 2 -
II. Product Features.....	- 4 -
2.1 Overview.....	- 4 -
2.2 Product features.....	- 4 -
2.3 Product appearance.....	- 5 -
2.3.1 Product appearance.....	- 5 -
2.3.2 Interface definition.....	- 5 -
III. Installation Instruction.....	- 7 -
3.1 Installation precautions.....	- 7 -
3.2 Installation instructions.....	- 7 -
3.3 Wiring.....	- 8 -
3.4 Photovoltaic array requirements.....	- 10 -
3.5 Cable selection requirements.....	- 10 -
3.6 Communication port description.....	- 10 -
IV. Operate instruction.....	- 11 -
4.1 Indicator function.....	- 11 -
4.2 Setting Button.....	- 11 -
4.3 LCD display.....	- 12 -
4.4 Setup operation.....	- 14 -
4.4.1 General parameters view.....	- 14 -
4.4.2 General parameter settings.....	- 15 -
4.4.3 Battery type settings.....	- 16 -
4.4.4 Combination button function settings.....	- 16 -
V. Device parameters.....	- 17 -
5.1 Protection function.....	- 17 -
5.2 Fault resolution.....	- 17 -

5.3 System maintenance.....	- 19 -
VI. Warranty	- 20 -
VII.Device parameters.....	- 21 -
7.1 System parameter table.....	- 21 -
7.2 Battery parameter reference table.....	- 22 -
VIII.Installation Dimension.....	- 23 -
IX. Packing list and Monitoring options.....	- 25 -

I. Safety instructions

1.1 Safety signs

The following safety symbols may appear in this manual and their meanings are as follows:

safety symbols	signification
 Danger	Indicates that if the safety warning is ignored, there is a serious accident that may lead to personal injury.
 Warning	Indicates that if safety warnings are ignored, there is a risk of serious injury, serious equipment damage or major business interruption.
 Notice	This means that if safety warnings are ignored, there is a risk of moderate injury, moderate equipment damage or partial business interruption.
 Instruction	Indicates that the content is additional information for the body.

For electrical and electronic equipment, safety involves the entire process of installation, commissioning, operation and maintenance. Therefore, incorrect use or misuse will endanger the life and personal safety of the operator or a third party and the safety of the equipment. In order to avoid personal injury and damage to the equipment, all safety, warnings and cautions such as the following are strictly observed during operation and maintenance.

1.2 Safety instructions



Warning!

All installation operations on the controller must be performed by a qualified technician. Professional and technical personnel must undergo special training, complete the manual and understand the safety related to the operation.

If a non-professional person performs installation operations and causes personal injury, the company will not be responsible.

Failure to install and operate the controller in accordance with the instructions in this manual will result in damage to the controller and will not be covered by our warranty.

① Before installation



Notice!

When receiving the product, first check the MPPT series controller for damage during transportation. If you find any problem, please contact our company or the transportation company immediately.

② Installing

Before installing the MPPT controller, make sure that the MPPT controller has not been electrically connected and powered.



Warning!

Damage to the MPPT controller caused by the following conditions, or other damages will not be covered by our warranty.

When configuring the PV array, ensure that the maximum short-circuit current on the DC side is within the allowable range of the MPPT controller, otherwise the MPPT may be irreparable.

When configuring the PV array, make sure that the open circuit voltage of each PV string does not exceed the maximum input range of the MPPT controller, otherwise the MPPT controller will be irreparable.

The selected controller charging current should not be greater than 0.3 times the battery capacity. If it is greater than the battery will be damaged or the battery life will be reduced.

Improper selection of the MPPT controller installation environment will affect machine performance and may cause machine damage.

Do not install the MPPT controller in a flammable or explosive place or in a place where flammable or explosive materials are stored.

Do not install the MPPT controller in an explosive location.

Do not install the MPPT controller in a location where it may be exposed to lightning strikes.

Do not install the MPPT controller in a place with a lot of salt spray.

Good ventilation is required when the MPPT controller is in operation.

The MPPT controller needs to be installed upright and ensure that the air duct is unobstructed.



Warning!

Always disconnect the PV array, battery, load, etc. (circuit breaker) or fuse before all devices are fully connected.

Prevent water from entering the inside of the controller.



Note!

All electrical installations must comply with local and national electrical installation standards.

To ensure safe operation, proper grounding, proper conductor size and the necessary short-circuit protection are required.

The connection cable must be selected to the appropriate specifications, and the connection is secure and well insulated.

After installation, check that all wiring connections are tight to avoid the risk of heat build-up due to virtual connections.

③ Operation



Danger!

Do not open the machine cover while the MPPT is powered!

④ Repair



Danger!

Repair work must be carried out by professional service technicians.

The machine needs to be powered off before maintenance, and it can be disassembled after waiting for 5 minutes after power off.

II. Product Features

2.1 Overview

Thank you for choosing the JN-MPPT-MINI/AL/BL/CL type solar charge controller. Based on multi-phase synchronous rectification technology and common anode design, this series of products adopts advanced high-speed processor and MPPT control algorithm, featuring high response speed, high reliability and high industrial standard.

The MPPT control algorithm used in this series can quickly track the maximum power point of the PV array in any environment and obtain the maximum energy of the solar panel in real time. The multi-phase synchronous rectification technology can guarantee the pole in any charging power environment. High conversion efficiency, compared with most of the current BUCK, greatly improve the energy efficiency of the solar system; the controller can be connected to the host computer through RS485, support WIFI module and GPRS module to expand APP cloud monitoring, can be applied to communication base stations, households Use systems, street lighting systems and field monitoring.

2.2 product features

- Advanced multi-phase synchronous rectification technology also has high conversion efficiency in low power charging environment.
- Has an ultra-wide PV array operating voltage range.
- Advanced MPPT maximum power point tracking technology, the tracking efficiency is not less than 99.5%, compared with the ordinary PWM algorithm, the efficiency is increased by 15 to 20%.
- Using high-quality imported components and advanced power conversion circuit, the maximum conversion efficiency can reach over 98%, the full load efficiency can reach 97%, and a variety of tracking algorithms can be combined to quickly track the maximum power point.
- Three-stage charging method: MPPT-Boost charging- Float charge.
- 12V/24V/48V battery system automatic identification function.
- RS485 communication can provide communication protocol to facilitate unified management and secondary development for customers.

- The controller running parameters can be viewed and set through the PC host computer and mobile phone APP. For details, refer to the host computer and APP manual (optional).
- With battery temperature compensation.
- It has comprehensive protection functions such as overcharge, over discharge, over temperature, overload, reverse connection and so on.

2.3 Product appearance

2.3.1 Product appearance

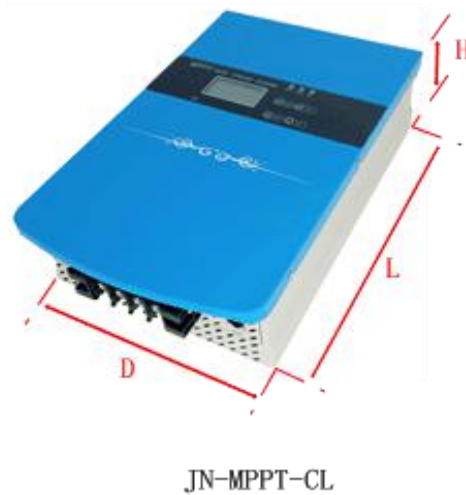

pic 2-1: Product appearance dimension drawing

Table 2-1: Product weight and size

parameter name	Weight and Size			
Model no.	JN-MPPT-MINI	JN-MPPT-AL	JN-MPPT-BL	JN-MPPT-CL
weight(kg)	0.55Kg	1.5kg	2.3kg	3.6kg
Size L*D*H(mm)	113*141*46mm	186*146*81mm	240*170*97mm	340*208*95mm

2.3.2 Interface definition



JN-MPPT-CL

pic2-2 Product interface definition

Table 2-2 Product interface definition

NO.	Name	Function	Instruction
1	PV+	Photovoltaic array positive electrode	PV array input
2	PV-	Photovoltaic array negative	
3	BAT+	Battery positive	Battery pack terminal
4	BAT-	Battery negative	
5	LOAD+	DC load positive	DC load output (JN-MPPT-CL does not have this output)
6	LOAD-	DC load negative	
7	Temp sensor	External temperature test terminal	Measuring battery temperature(JN-MPPT-MINI is none)
8	RS485	Communication port	Realize the monitoring of host computer, WIFI and GPRS communication

III. Installation Instruction

3.1 Installation precautions

- (1) You must read the entire installation chapter and familiarize yourself with the installation steps before installation.
- (2) Be very careful when installing the battery. For the installation of the open lead-acid battery, wear a protective mirror. When it comes into contact with the battery acid, please rinse it with clean water.
- (3) Avoid placing metal objects near the battery to prevent the battery from short-circuiting.
- (4) Acid gas may be generated when the battery is being charged to ensure good ventilation around the battery.
- (5) Please install indoors and install outdoors to avoid direct sunlight and rain.
- (6) The connection point of the virtual connection and the corroded wire may cause great heat to melt the insulation of the wire, ignite the surrounding materials, and even cause fire, so ensure that the connectors are tightened, and the wires are preferably fastened with the cable tie. To avoid loose wires when the application is moving and the wires are shaken.
- (7) The installed battery pack should match the controller charging voltage and the recommended charging current range.



Danger!

Explosion hazard! Never install the controller and battery in the same confined space! Also do not install in a confined space where battery gas may collect.

3.2 Installation instructions

Step 1: Choose the installation location

Avoid installing the controller in direct sunlight, high temperatures, and easy access to water, and ensure adequate ventilation around the controller.

Step 2: Unpacking and checking

(1) Check the outer packaging for damage or deformation;

(2) Unpacking inspection: one controller, one manual, one attachment, etc.;

(3) Check the appearance of the mainframe and the accessories are in good condition

If you are concerned about the above abnormal situation, please contact us.

Step 3: Fixed controller

Install the mounting ear fittings on the top of the top of the cabinet at the reserved installation position. Fix the controller to the mounting platform or cabinet mounting bracket with screws through the mounting ears. Allow sufficient ventilation and cooling space around the installation.

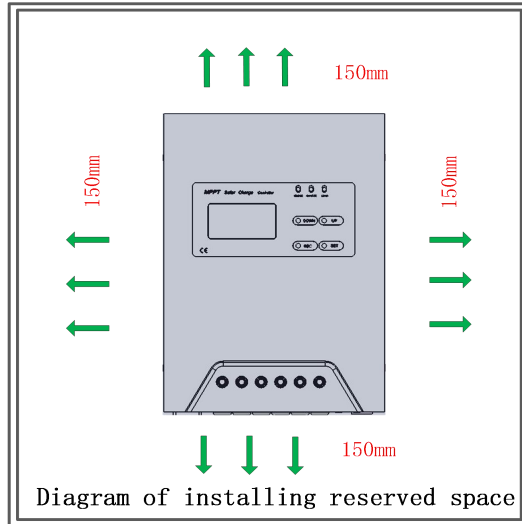

pic 3-1 Reserved space map around the equipment installation

3.3 Wire



Note: For installation safety, we recommend a wiring sequence
 Note: The MPPT series controller is a common negative design.



Caution: Do not connect the electrical equipment that exceeds the surge power of the controller to the load terminal to prevent damage to the controller!



Warning: When you need to use the mobile, make sure that all the wiring are fixed. Because the virtual connection points may cause heat to accumulate, it may cause fire in severe cases;

Step 1: Connect the battery, PV module, load, temperature sensor, monitoring background.

Connect the battery, load, PV module, temperature sensor, monitoring background (host computer / WIFI module / GPRS module) in turn, disconnect all switches during the wiring process, pay attention to distinguish between positive and negative.

Before connecting the battery, make sure the battery is in a normal state to ensure normal operation of the system.



Warning: Do not connect the PV panel to the battery terminal of the controller, as it will burn out the controller. It is strictly forbidden to make the battery positive or negative, extremely short circuit, otherwise it will cause fire or explosion hazard, please be careful.

Step 2: Wiring diagram

Lock the cable to the binding post through the mounting hole on the lower side of the cabinet.

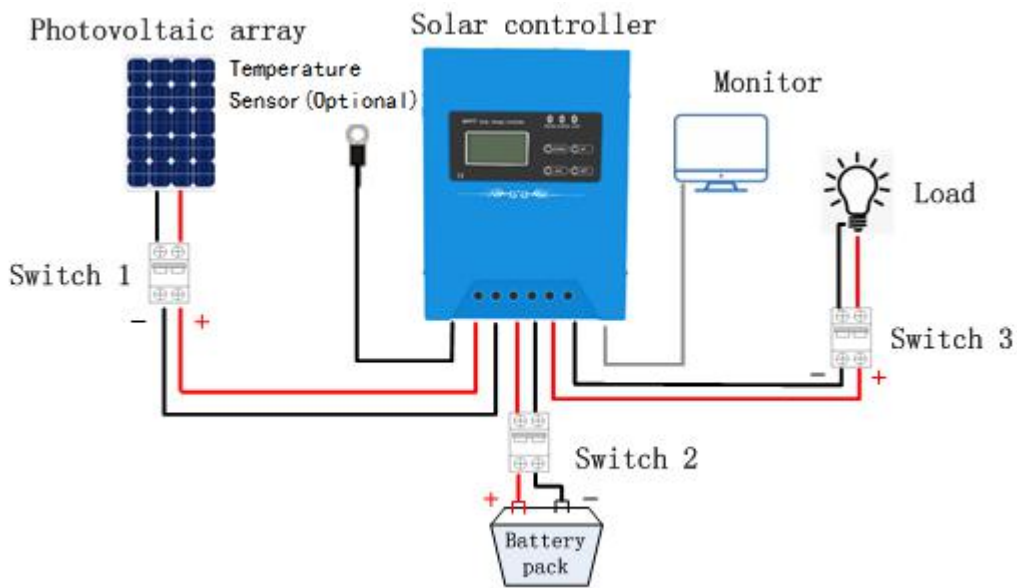

Pic3-2 Wiring diagram

Description: The monitoring background supports the PC host computer, supports the WIFI module and the GPRS module to expand the APP cloud monitoring (optional). For details, see the PC host computer and the APP user manual;

The controller defaults to lead-acid batteries. If you need to connect the other types of batteries, you need to set the corresponding battery type and series number. For details, please refer to the relevant settings of the PC host computer or APP manual.



Caution!

1. Danger of electric shock! It is forbidden to touch the live parts of high voltage photovoltaic modules with bare hands;
2. Make sure that the solar array voltage in the system does not exceed the maximum input voltage range of the controller;
3. The system needs to be connected to the inverter. Please connect the inverter directly to the battery. Do not connect to the load end of the controller.

Step 3: Check the connection

Check that all wiring polarity is correct and the terminals are locked;

Step 4: Power On Sequence

Recommended opening and closing sequence: sequentially close the battery pack switch, photovoltaic switch or load switch;

Turn off the PV and load switches before turning off the battery switch.

3.4 Photovoltaic array requirements

Table 3-1 Photovoltaic electrical parameters

		Photovoltaic parameters		
MODEL	JN-MPPT-MINI	JN-MPPT-AL	JN-MPPT-BL	JN-MPPT-CL
PV array open circuit voltage range	20V~80V (12V battery system)	20V~100V (12V battery system)		20V~100V (12V battery system)
		40V~145V (24V battery system)		40V~145V (24V battery system)
	40V~80V (24V battery system)	80V~145V (48V battery system)		80V~240V (48V battery system)
				160V~240V(96V battery system)

3.5 Cable selection requirements

The following table shows the diameter of the copper wire according to the current level. The actual cable size is greater than or equal to the data in the table:

Table 3-2 cable size

		Cable selection table								
Current level /A	10	20	30	40	50	60	70	80	100	120
Wire diameter /mm ²	2	4	6	8	10	12	14	16	20	24
AWG	14	11	9	8	7	6	5	5	4	3

3.6 Communication port description

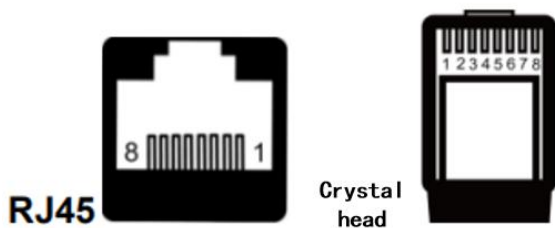

Needle	Definition	Note
1/2/3/4	Air	Air
5	RS485-A	RS485-A
6	RS485-B	RS485-B
7	VDC +12	12V/400mA
8	GND	Power ground

IV. Operate instruction

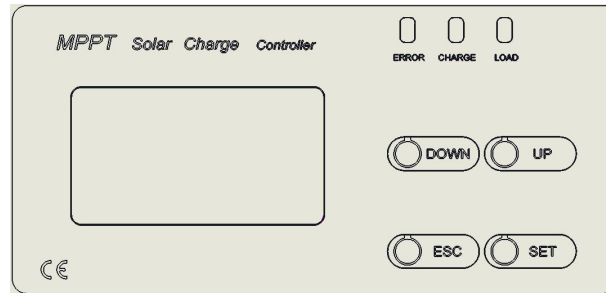

pic 4-1 Display panel image

4.1 Indicator function

The LED indicators on the display panel are fault light (red), charge indicator (yellow), and load indicator (green). The functions are defined as shown in the following table.

Table 4-1 Indicator definition

	Indicator light	status	definition	Remarks
1	Fault indicator (red)	Extinguished	Working normally, no fault	
2		Constantly light on	error	
3	Charging indicator (yellow)	Light off	No charging	
4		Light on	MPPT charging	
5		Slow flashing	Floating charge	
6		Fast flashing	Boost charging	
7	Output indicator (green)	Light on	Output normally	
8		Light off	Light control, timing light normally off output	
9		Slow flashing	Battery over discharge, load is off	
10		fast flashing	Battery over charge, load is off	

4.2 Setting Button

table4-2 setting button function

button	Effect	Remarks
SET	Function 1: Main menu key, function 2: parameter setting save key;	
ESC	Exit the setup interface button;	
UP	Function 1: display page up display, function 2: parameter setting plus;	

DOWN	Function 1: Display page down parameter, function 2: parameter setting minus;	
------	---	--

UP and DOWN button Switching function:

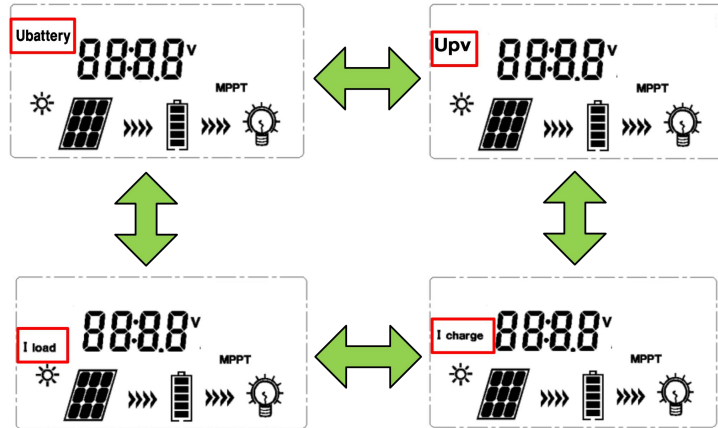

pic 4-2 UP and DOWN Button display interface switching diagram

4.3 LCD display

The display of the controller adopts the segment code screen display mode, and the display layout diagram is as follows:

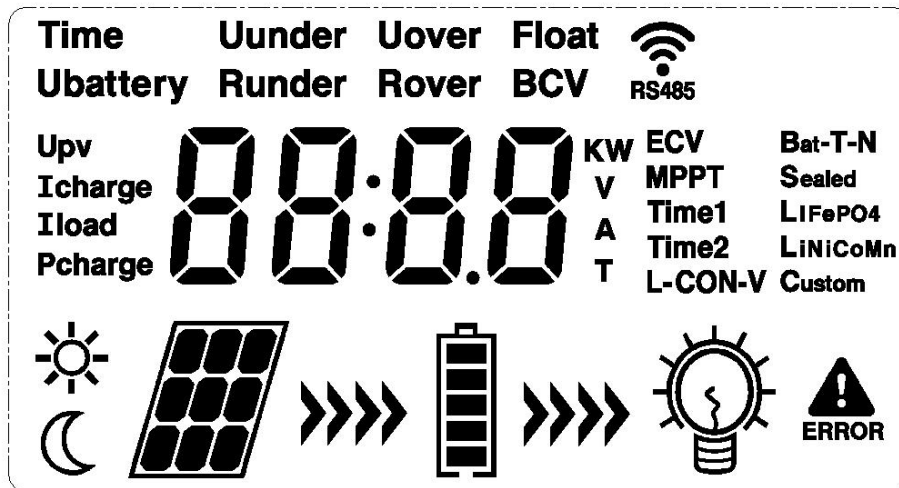

pic 4-3 Display

Table 4-3 Icon function introduction

Icon name	definition	Function Description
	day	The icon lights up to indicate daylight
	night	The icon lights up to indicate the night





	Solar panel	The icon lights up to check the PV array access
	battery	The icon lights up to indicate battery access and the inside indicates battery voltage
	load	The load is lit to indicate that the load has an output
	Status icon	The icon lights up and scrolls to indicate the charge status and discharge status, respectively.
	Failure icon	The icon flashes to indicate that the system has a fault condition.

Table 4-4 Field function introduction

Field name	Definition	Function Description
Ubattery	Battery voltage	The field lights up and displays the current battery voltage in the data display area
U pv	PV panel voltage	The field lights up and displays the current PV panel voltage in the data display area
Icharge	Charge current	The field lights up and displays the current battery charging current in the data display area
Iload	Discharge current	The field lights up and displays the current battery discharge current in the data display area
Pcharge	Charge Power	The field lights up and displays battery charging power in the data display area
Uunder	Undervoltage	The field lights up, can set the battery undervoltage value, when the battery undervoltage, this field flashes
Runder	Return of undervoltage	Field lights up, battery undervoltage return voltage can be set
U over	Overcharge voltage	The field lights up and the battery overcharge voltage can be set. When the battery is overcharged, the field flashes
Rover	Overcharge return	Field lights up, battery overcharge return voltage can be set
Float	Floating Charge Voltage	The field lights up to set the battery floating charge voltage, and in the floating charge stage, the field flashes

BCV	Boost charge	The field lights up to set the battery to raise the charging voltage, and during the lifting charging phase, the field flashes
ECV	Equalized charge	The field lights up to set the battery equalization charge voltage, and in the equalization charge phase, the field flashes
MPPT	MPPT charge	During the MPPT charging phase, the field flashes.
Time	Time control period 1 set	Field lit, you can set the first time control (light control first light), when set 24, the controller is for household mode. The default value is 24.
Time1	Time Control Time 2 Set	Field lit, in street lamp mode, you can set the second time (light control lights after the lights out time).
Time2	Time Control Period 3	Field lit, in street lamp mode, can set the third time period (light control second light).
L-CON -V	Light control Voltage Set	The field lights up, the first digit of the display area displays 1, and the light control on (light control will be on) voltage can be set; after the light control is set, the first digit displays 2, and the light control off (light control lights will be off) voltage can be set .
Sealed	Lead acid batteries	Field light up, battery type is lead acid type;
LiNiCoM-n	Lithium ternary	Field light up, battery type is ternary lithium battery;
LiFePO4	Lithium iron phosphate	Field light up, battery type is lithium iron phosphate battery;
Custom	Customized	The field lights up and the number of series batteries can be set customized.
ERROR	Alarm Instructions	When there is a fault, the field will light up

4.4 Setup operation

4.4.1 General parameters view

Press the Settings (set) button in standby mode, enter the parameter view settings interface, and press the SET key to enter the U under→R under→ U over→R over →Float→BCV→ECV→L-CON -V→Time→Time 1→Time 2→Bat-T-N, Check the process

with reference to the following figure, in any interface press (ESC) button exit settings interface, back to the main menu interface, back to the standby interface;

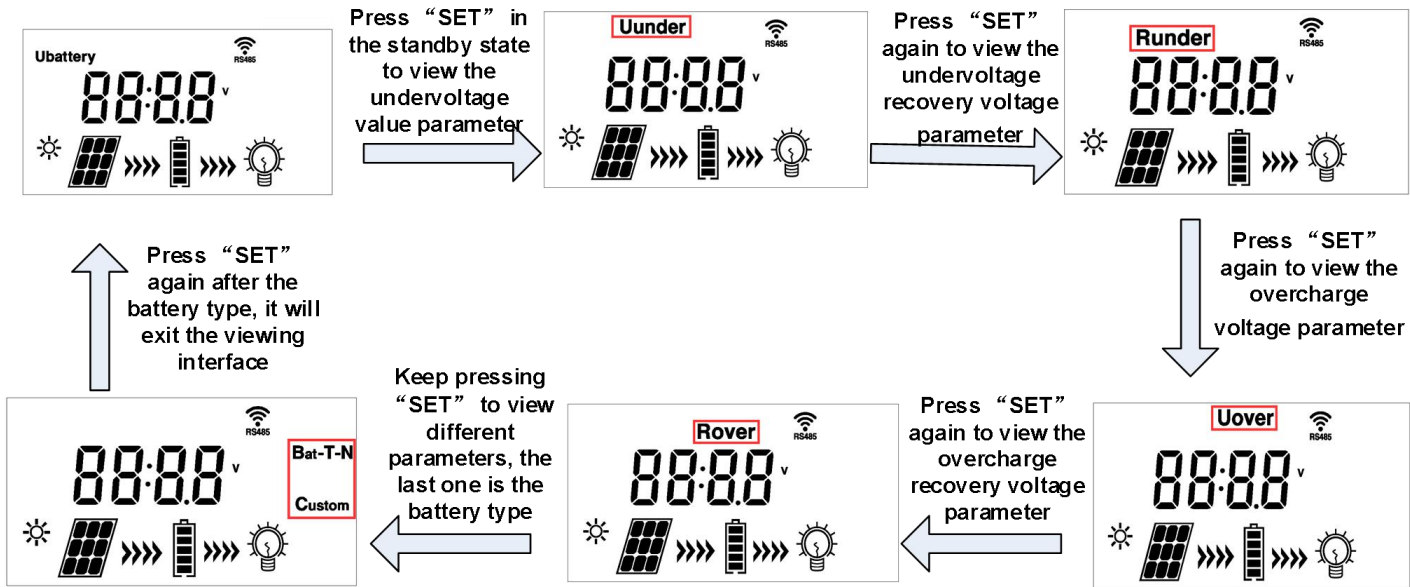

Figure 4-3 General Parameters View

4.4.2 General parameter settings

Press the setting (set) button in standby mode, enter the undervoltage setting interface, the setting process refers to the following figure, press (ESC) button in any interface to exit the setting interface, return to the standby interface, other conventional parameter settings are similar to the undervoltage setting;

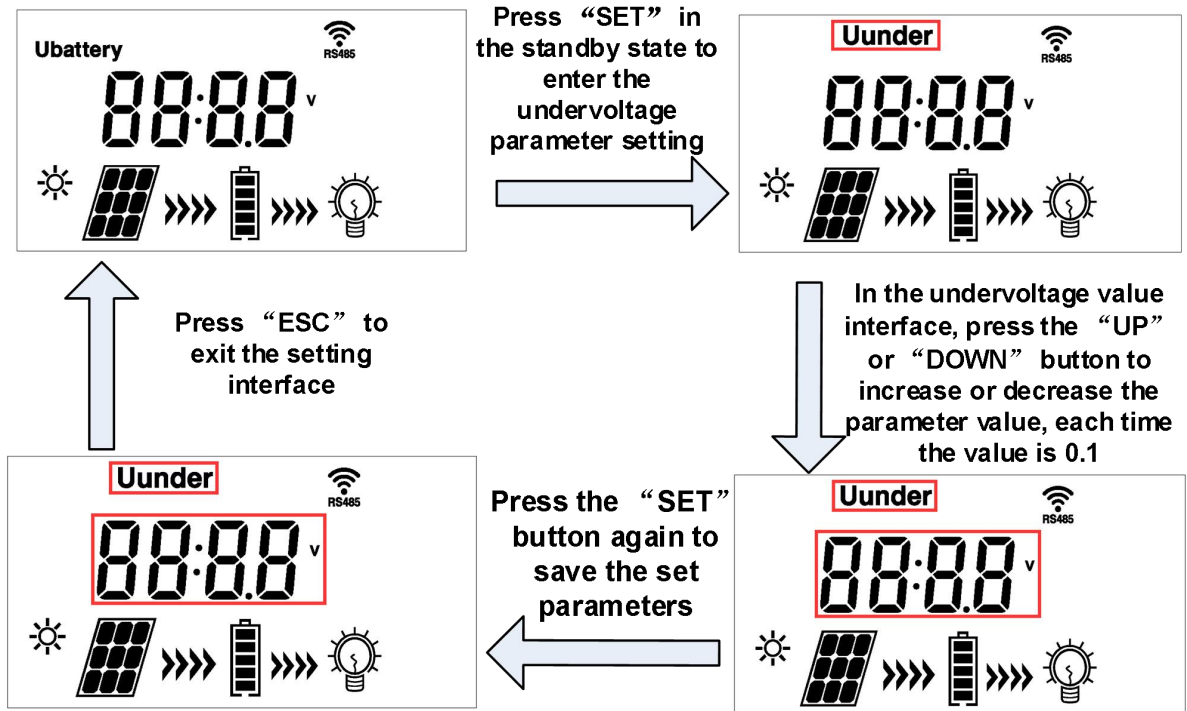

Figure 4-4 General Parameter Settings - Under voltage Point Settings

4.4.3 Battery type settings

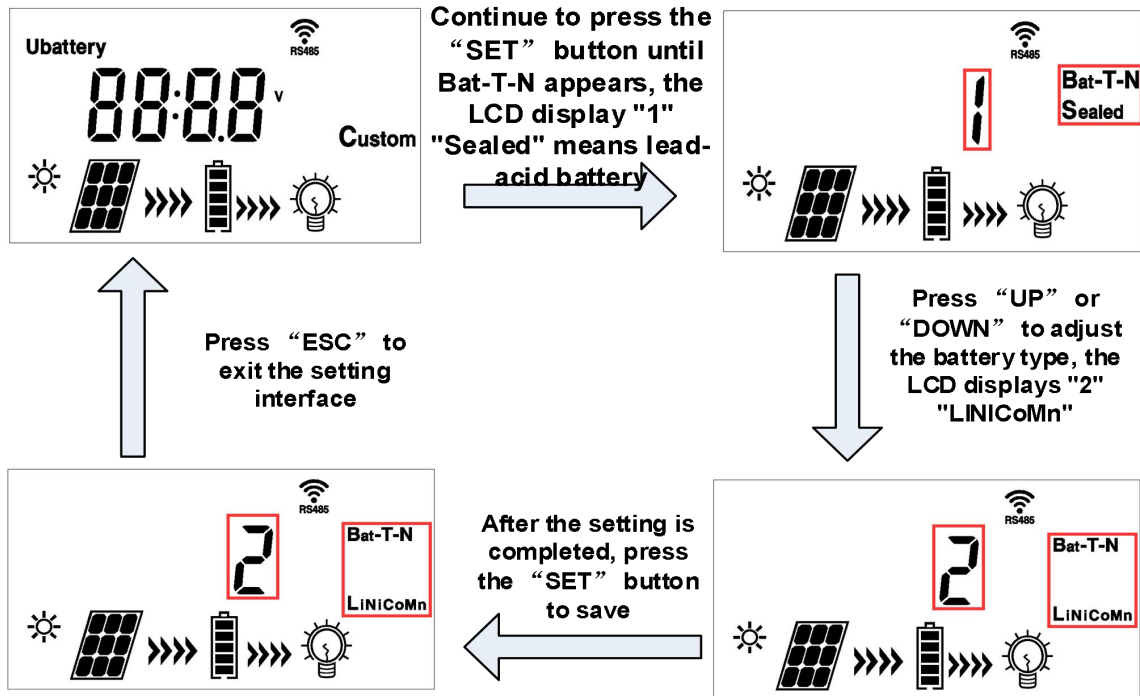



Figure 4-5 Battery Type Settings

4.4.4 Combination button function settings

1. Restore factory settings: Press the SET and DOWN buttons simultaneously for 3 seconds in standby mode, the system will restore the factory settings;
2. ID address modification: Press the SET and UP buttons simultaneously for 3 seconds in the standby state, and display the ID in the first two digits of the data in the display area. Press the UP or DOWN button at this time. Set the system ID (address).

For the setting method of connecting the PC to PC or APP (WIFI or GPRS mode), please refer to the corresponding PC manual and APP manual respectively;

 Instruction	The PC host computer or APP (WIFI or GPRS mode) is an optional accessory. The device can only use one mode for single communication, and cannot use several communication modes at the same time!
---	---

V. Device parameters

5.1 Protection function

table5- 1.Protection function reference table :





Protection function	instruction
PV over voltage protection	When the PV array charging voltage exceeds the controller's rated input voltage range, charging will stop.
Battery polarity reverse connection	When the polarity of the battery is reversed, the controller will not work and will not be damaged. After correcting the wiring error, re-open the opportunity to continue normal operation.
Battery over discharge protection	When the battery voltage is lower than the set undervoltage value, the discharge of the battery will be automatically stopped to prevent the battery from being over-discharged and damaged.
Battery overload protection	When the controller output current is greater than the set value, the load output will be automatically stopped to prevent the battery from being over-discharged and damaged.
Battery over volatge protection	When the battery voltage reaches the overvoltage protection setting value, the battery will be automatically stopped to prevent the battery from being overcharged and damaged.
Night anti-reverse protection	At night, since the battery voltage is greater than the voltage of the photovoltaic module, the automatic protection prevents the battery voltage from being discharged through the photovoltaic module;
Equipment overheat protection	The controller has its own temperature sensor. When the temperature is higher than the set value, the charging will stop. When the temperature is lowered, it will automatically start to work.
High voltage surge	This controller can only protect high-voltage surges with low energy. In areas with frequent lightning, it is recommended to install an external lightning arrester.

5.2 Fault resolution

If the following symptoms occur, please check and troubleshoot as follows:

Table 5-2 Troubleshooting table

ERROR	Indicator status and alarm icon	possible reason	Solution

Array over voltage	Red light, V PV and  icon flashes	More PV arrays in series	Disconnect the PV array, reduce the number of PV arrays connected in series, and ensure that the PV array open circuit voltage does not exceed the set value in the “Table 3-1 PV Electrical Parameters” table;
Battery over voltage (overcharge)	Red light on, U over and  flashes	1. The controller over voltage protection point is lower than the highest charging range; 2. The battery is aging or over-discharged; 3. The battery is over-discharged; 4. Large dynamic changes in load;	1. Reset the battery over voltage protection point through the device button or PC host computer or APP; 2. The battery needs to be replaced after aging; 3. Over-discharge requires manual setting of battery voltage level; 4. Reduce large dynamic changes in load;
Battery under voltage (over discharge)	U under and  flashes	Battery voltage value is lower than the under voltage protection setting	1. Reduce or disconnect the load. If the alarm is released, the battery voltage returns to normal, indicating that the load power is too large or the battery voltage and capacity are low. It is easy to cause under voltage protection with heavy load; 2. Disconnect the load controller and still alarm, the battery voltage does not return to the over-discharge recovery setting value, and the battery pack needs to be charged by PV or other means, so that the fault can be released after the battery pack voltage reaches the recovery point set value.
	The indicator light is off and the display is not displayed.		Battery voltage is lower than device startup voltage
Heat sink over heating	Red light on,  flashes	1. The ambient temperature is too high, the heat dissipation of the equipment is poor, and the fan is not well ventilated; 2. The fan is damaged.	1. Check the installation environment of the equipment, remove the debris of the equipment, and ensure that the fan is ventilated smoothly; 2. The fan needs to be replaced if it is damaged.
Charge current	Red light on, Icharge  flashes	Charging over current protection check for abnormal current detection and malfunction	If you restart it several times, if you can't solve it, you need to go back to the factory for repair;

Over loading	Red light on, I load and  ERROR flashes	Load power is too large	1. Reduce the load power; 2. Restart and release the fault; 3. Without excessive sensibility and capacitive load;
Remark: The above fault phenomenon can not be turned on except the battery under voltage, other faults can refer to the fault information through the PC background or mobile APP;			

5.3 System maintenance

In order to maintain optimal long-term performance, it is recommended to perform the following checks twice a year.

Verify that the controller is securely installed in a clean, dry environment.

- (1) Verify that the airflow around the controller is not blocked and remove any dirt or debris from t 1) Check that all exposed wires are damaged by the sun, friction with other objects around them, dryness, insect or rodent damage. Repair or replace the wires if necessary.he heat sink.
- (2) Check that all exposed wires are damaged by the sun, friction with other objects around them, dryness, insect or rodent damage. Repair or replace the wires if necessary.
- (3) Tighten the screws of all electrical connection terminals as recommended.
- (4) Check the grounding of all parts of the system and verify that all grounding conductors are securely and properly grounded.
- (5) Check all terminals for corrosion, insulation damage, high temperature or signs of burning, discoloration, and tighten the terminal screws to the recommended torque.
- (6) Check for dirt, nesting insects and corrosion, and clean as required.
- (7) If the arrester has failed, replace the failed arrester in time to prevent lightning damage to the controller or even other equipment of the user.



Note: Danger of electric shock!

When doing this, you must ensure that all power to the controller has been disconnected before performing the appropriate checks or operations!

VI. Warranty commitment

The MPPT controller has a one-year free warranty and the warranty period begins on the date of sale.

Repair Procedures Before requesting repairs, check the user manual to determine if the controller does have a problem. If this is not possible, return the problem controller to the company, prepay the shipping fee, and provide date and location information related to the purchase. In order to enjoy the fast return warranty service, the returned product must indicate the model, serial number and the detailed cause of the fault, as well as the type of components in the system and related parameters, battery and system load conditions; this information is very important for quickly solving your repair requirements. .

If the controller is damaged due to improper use of the customer or failure to follow this manual, the company is not responsible for it! The maintenance procedure is carried out in accordance with the above procedure and only the maintenance cost is charged.

Disclaimer: The company reserves the right to change products, product updates without prior notice!

Version number: V1.0

VII. Device parameters

7.1 System parameter table

parameter name	Parameter value (and adjustable range)														
MODEL	JN-MPPT-MINI			JN-MPPT-AL			JN-MPPT-BL					JN-MPPT-CL			
Current rating (A)	10	20	30	40	50	30	40	50	60	70	50	60	80	100	120
Maximum charging current (A)	10	20	30	40	50	30	40	50	60	70	50	60	80	100	120
PV maximum input power (12V) (W)	120	240	360	480	600	360	480	600	720	840	600	720	960	1200	1440
PV maximum input power (24V) (W)	240	480	720	960	1200	720	960	1200	1440	1680	1200	1440	1920	2400	2880
PV maximum input power (48V) (W)	--	--	1440	1920	2400	1440	1920	2400	2880	3360	2400	2880	3840	4800	5760
PV maximum input power (96V) (W)	--	--	--	--	--	--	--	--	--	--	4800	5760	7680	9600	--
Output maximum current(A)	7	14	21	28	35	21	28	35	42	49	--	--	--	--	--
PV panel open circuit input voltage range (V)	20V ~ 80V(12V battery system)		20V ~ 100V(12V battery system)								20V ~ 100V(12V battery system)				
			40V ~ 145V(24V battery system)								40V ~ 145V(24V battery system)				
	40V ~ 80V(24V battery system)		80V ~ 145V(48V battery system)								80V ~ 240V(48V battery system)				
			160V ~ 240V(96V battery system)								160V ~ 240V(96V battery system)				
System identification voltage range(V)	12V battery system				DC9V-DC16V										
	24V battery system				DC18V-DC32V										
	48V battery system				DC42V-DC60V										
	96V battery system				96V is a stand-alone system										
MPPT efficiency	> 99.5%														
Conversion efficiency	> 98%														
Operating mode	The default is the household mode 24H														
Operating environment parameters															
Ambient temperature	-20℃ ~ 50℃														
Storage temperature	-30℃ ~ 70℃														
Humidity	10% ~ 90%														

Protection grade	IP30
------------------	------

7.2 Battery parameter reference table

Lead-acid batteries				
System rated voltage (v)	12V system (1 in series)	24Vsystem (2in series)	48Vsystem (4in series)	12Vdefault
Over voltage (v)	13 ~ 17V	26 ~ 34V	52 ~ 68V	15.5V
Over voltage return (v)	13 ~ 17V	26 ~ 34V	52 ~ 68V	15V
Charge limit voltage (v)	9 ~ 15V	18 ~ 30V	36 ~ 60V	14.9V
Boost charge (v)	9 ~ 15V	18 ~ 30V	36 ~ 60V	14.4V
Boost charge return (v)	9 ~ 15V	18 ~ 30V	36 ~ 60V	13.9V
Float voltage (v)	9 ~ 15V	18 ~ 30V	36 ~ 60V	13.8V
Over discharge (v)	7 ~ 13V	14 ~ 26V	28 ~ 52V	10.8V
Over discharge return (v)	9 ~ 15V	18 ~ 30V	36 ~ 60V	13.1V
Ternary lithium battery (single section 3.7V)				
System rated voltage (v)	3 series parameter range	6 series parameter range	12 series parameter range	3in series default value
Over voltage (v)	10.5 ~ 15V	21 ~ 30V	49 ~ 70V	13.5V
Over voltage return (v)	10.5 ~ 15V	21 ~ 30V	49 ~ 70V	12.6V
Charge limit voltage (v)	10.5 ~ 15V	21 ~ 30V	49 ~ 70V	12.6V
Boost charge (v)	10.5 ~ 15V	21 ~ 30V	49 ~ 70V	12.3V
Boost charge return (v)	10.5 ~ 15V	21 ~ 30V	49 ~ 70V	12V
Float voltage (v)	10.5 ~ 15V	21 ~ 30V	49 ~ 70V	12.3V
Over discharge (v)	6 ~ 12V	12 ~ 24V	28~56V	9.3V
Over discharge return (v)	6 ~ 13.5V	12 ~ 27V	28 ~ 63V	10.5V
Lithium LIFEPO4 (single section 3.2V)				
System rated voltage	3 series parameter range	6 series parameter range	12 series parameter range	3in series default value
Over voltage (v)	9 ~ 12V	18 ~ 24V	42 ~ 56V	11.7V
Over voltage return (v)	9 ~ 12V	18 ~ 24V	42 ~ 56V	11.1V
Charge limit voltage (v)	9 ~ 12V	18 ~ 24V	42 ~ 56V	11.1V
Boost charge limit (v)	9 ~ 12V	18 ~ 24V	42 ~ 56V	10.8V
Boost charge return (v)	9 ~ 12V	18 ~ 24V	42 ~ 56V	10.2V
Float voltage (v)	9 ~ 12V	18 ~ 24V	42 ~ 56V	10.8V
Over discharge (v)	6 ~ 9V	12 ~ 18V	28~42V	8.4V
Over discharge return (v)	6 ~ 12V	12 ~ 24V	28 ~ 56V	9.6V

VIII. Installation Dimension

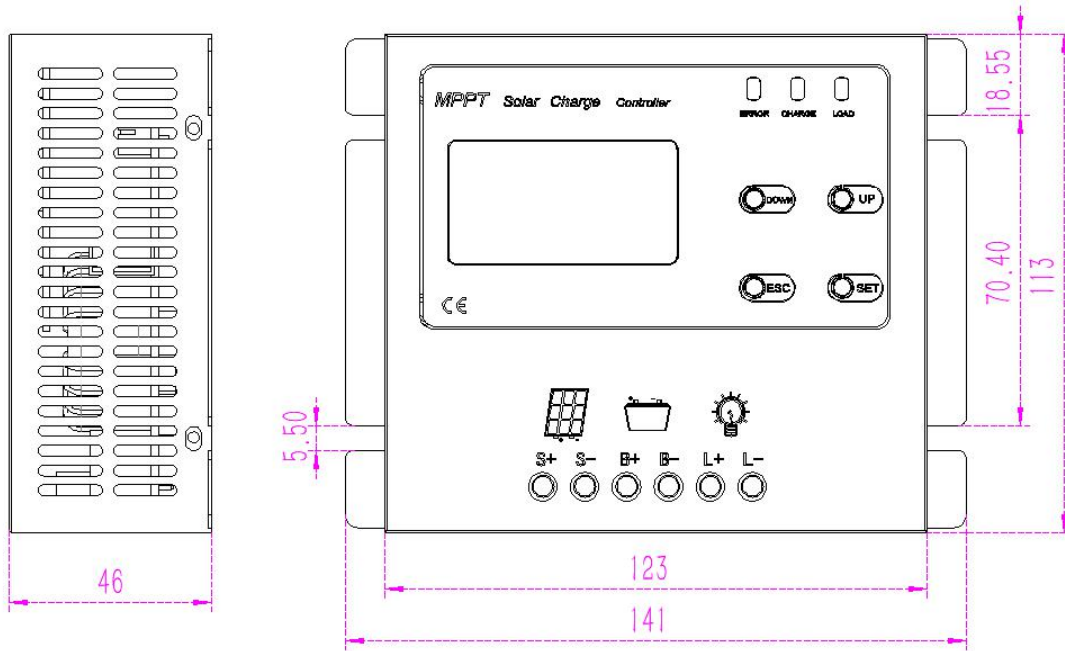

pic 8-1 MPPT-MINI Installation dimension

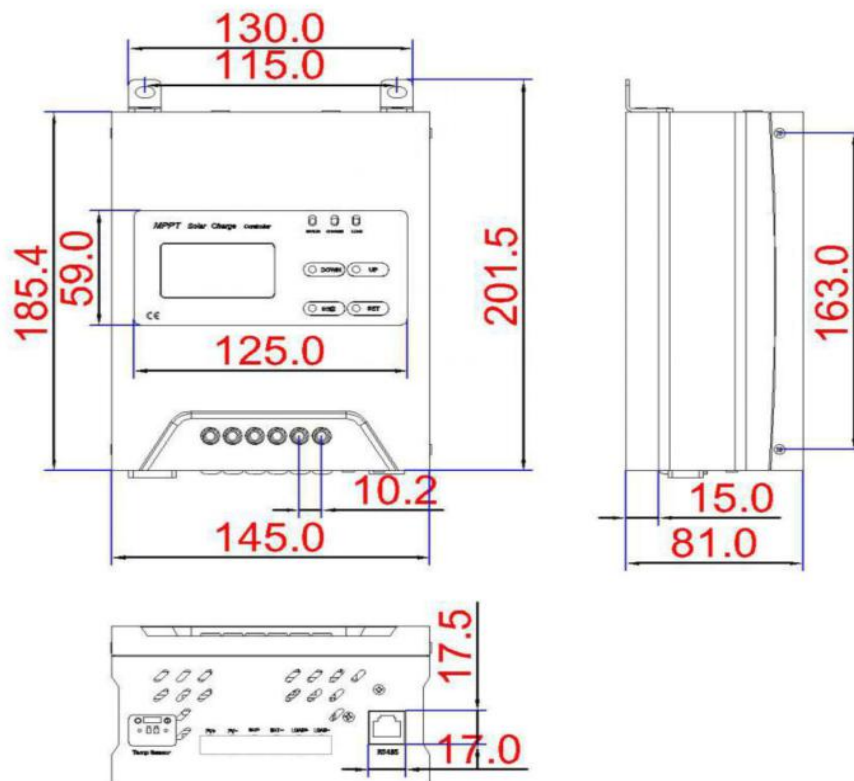

pic 8-2 MPPT-AL Installation dimension

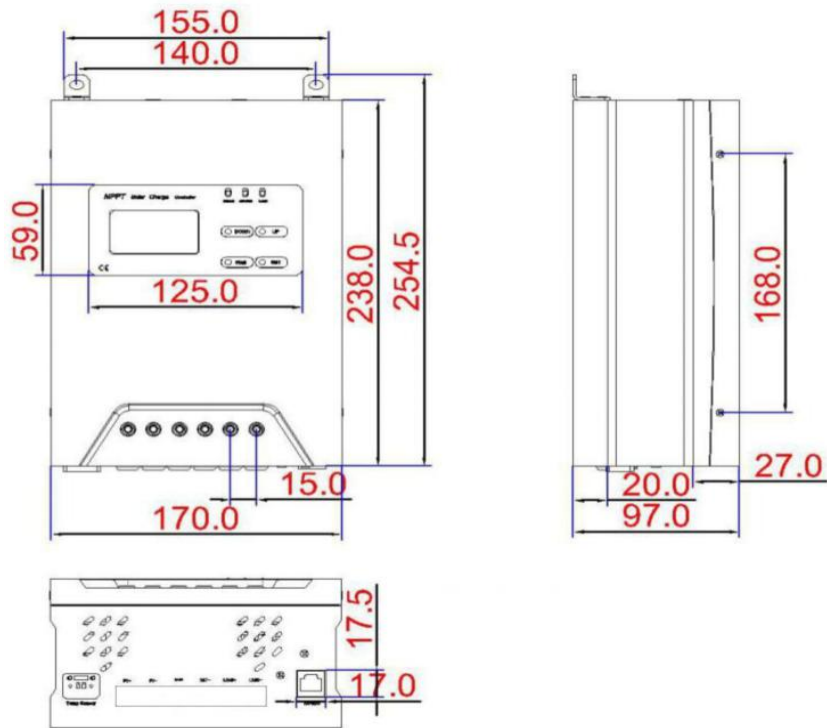

pic 8-3 MPPT-BL Installation dimension

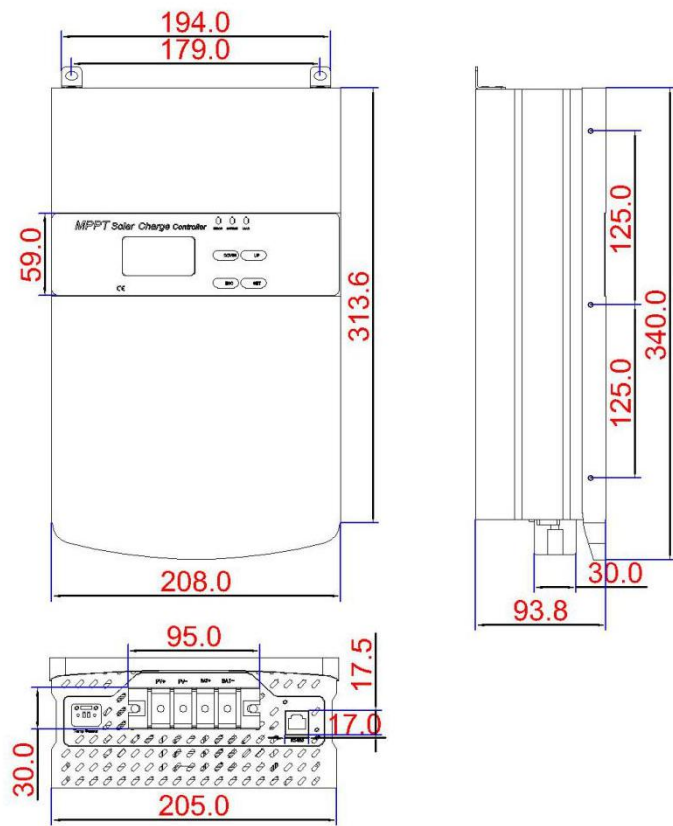

pic 8-4 MPPT-CL Installation dimension

IX. Packing list and Monitoring options

No.	name	quantity	remark
1	JN-MPPT-MINI/AL/BL/CL controller	1 piece	
2	User manual	1 piece	
3	External battery temperature probe	1 set	optional
4	Monitoring cd software	1 piece	optional
5	RJ45 to USB module	1 piece	optional
6	1.5m Special network cable	1 piece	
7	Host computer communication instructions	1 piece	
8	RJ45 to WIFI module	1 piece	optional
9	0.2m Special network cable	1 piece	
10	APP User manual	1 piece	
11	RJ45to GPRS module	1 piece	optional
12	0.2m Special network cable	1 piece	
13	APP User manual	1 piece	