

## Servo Power Wiring Resistance

We've discovered that the +5V power wiring in Doug's HFR has some significant resistance, (reference issue 73) and we can apply Ohm's law to see what this will do to the voltage that actually gets to the PCA9685 servo controllers.

We can use this model for the power going to a single servo controller:

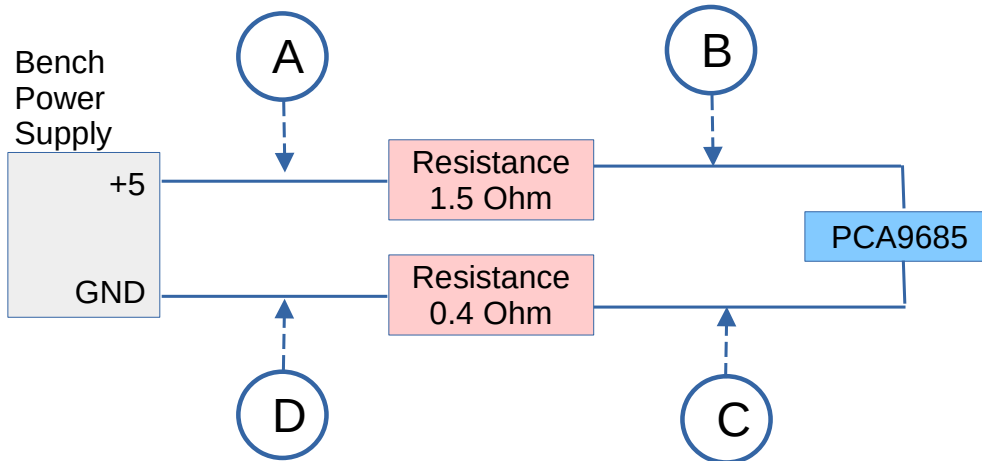

We can calculate the voltage drops across the resistances, i.e. between A and B, and between C and D. To do this we need to know the current in the circuit, so we'll calculate for 3 cases which depend on the number of servers energized and how much load they're working against. In particular, we'll use .1, .3, and 1.0 Amps.

The voltage drop obeys Ohms law, Voltage = current \* resistance. So the voltage drop across AB for a .1 AMP load is  $V = I * R = .1 \text{ Amp} * 1.5 \text{ Ohms} = .15 \text{ volts}$

Similarly, in the .1 Amp case, the voltage drop across CD is  $.1 * .4 = .04 \text{ volts}$

So, of the 5.0 volts we started with, there is  $5.0 - .15 - .04 = 4.81 \text{ volts}$  left for the PCA9685. Dangerously close to the 4.8 lower limit of it's specifications.

Doing the same calculations for the other current values results in these PCA9685 voltages:

Current	AB drop	CD drop	Total drop	PCA volts
0.1	$.1 * 1.5 = .15$	$.1 * .4 = .04$	$.15 + .04 = .19$	$5.0 - .19 = 4.81$
0.3	$.3 * 1.5 = .45$	$.3 * .4 = .12$	$.45 + .12 = .57$	$5.0 - .57 = 4.43$
1.0	$1 * 1.5 = 1.5$	$1 * .4 = .4$	$1.5 + .4 = 1.9$	$5.0 - 1.9 = 3.1$

If we can get the resistance down to .1 Ohms, same as from my IMP to the power supply:

Current	AB drop	CD drop	Total drop	PCA volts
0.1	$.1 * .1 = .01$	$.1 * .1 = .01$	$.01 + .01 = .02$	$5.0 - .02 = 4.98$
0.3	$.3 * .1 = .03$	$.3 * .1 = .03$	$.03 + .03 = .06$	$5.0 - .06 = 4.94$
1.0	$1 * .1 = .1$	$1 * .1 = .1$	$.1 + .1 = .2$	$5.0 - .2 = 4.8$
5.0	$5 * .1 = .5$	$5 * .1 = .5$	$.5 + .5 = 1.0$	$5.0 - 1.0 = 4.0$

Conclusion: we need to get the 5V wiring resistance down to .1 Ohms, AND we need to feed a voltage higher than 5.0 volts if we expect servo current requirements over 1 AMP.