

Product No.	ELPM482-00005	Revision	0.2
-------------	---------------	----------	-----

**CONFIDENTIAL**

PRODUCT SPECIFICATION

# 4.84kWh Lithium Ion Energy Storage System

1. Customer: Vertiv
2. Product Number: ELPM482-00005
3. Received Marking

Division			
Signature			
Date	/ /	/ /	/ /

4. Date of Application (YYYY/MM/DD):
5. Supplier: SAMSUNG SDI Co., Ltd.

Development			QA	
Issued	Checked	Approved	Checked	Approved

# CONFIDENTIAL

## Revision History

Revision	Date	Description	Pages Changed
0.1	2018.09.06	Draft	
0.2	2019.01.25	Draft	
	2019.03.11	Revised Protection function for safety. 7. Protection 8. save data and period	26 - 31
	2019.03.19	4.3 BMS block diagram 4.4 BMS Key components 7. Protection 8. LED Indication 9. Module ID Dip Switch Configuration	

TENTATIVE

# CONFIDENTIAL

## Table of Contents

Revision History .....	2
Table of Contents .....	3
Tables .....	5
Figures.....	6
Acronyms and Abbreviations .....	7
<b>1. Product Overview.....</b>	<b>8</b>
1.1 Scope .....	8
1.2 Product Description .....	8
<b>2. Safety Information and Handling .....</b>	<b>9</b>
2.1 Safety Symbols .....	9
2.2 General Safety Information .....	10
2.2.1 Protective Equipment.....	10
2.2.2 Organic Solvent Electrolyte .....	10
2.2.3 Electrolyte Vent Product .....	11
2.2.4 High Voltage Sources.....	11
2.2.5 Unloading and Unpacking .....	11
2.2.6 Storage .....	12
2.3 General Handling Information .....	12
<b>3. Module Specification(T.B.D).....</b>	<b>13</b>
<b>4. Product Structure and Block Diagram.....</b>	<b>14</b>
4.1 Product structure .....	14
4.2 Front View .....	14
4.3 BMS block diagram.....	15
4.4 BMS Key components .....	15
<b>5. Connector Configuration.....</b>	<b>16</b>
5.1 Dry Contact, External LED Specification.....	17
5.2 External connecting ON/OFF push switch Specification .....	17
<b>6. Protocol .....</b>	<b>19</b>
6.1 Protocol ID Set Dip switch configuration.....	19
6.2 Module to PCS CAN Communication .....	20
6.3 Module to PCS RS485 Communication .....	23
<b>7. Protection .....</b>	<b>28</b>
<b>8. save data and period .....</b>	<b>32</b>
<b>8. LED Indication .....</b>	<b>33</b>
8.1 Normal Status Display .....	33
<b>9. Module ID Dip Switch Configuration .....</b>	<b>34</b>
9.1 Module ID set.....	35
9.2 Dip Switch Set of Single Module System .....	36
<b>10. Drawings.....</b>	<b>37</b>
<b>11. Installation.....</b>	<b>38</b>
11.1 Overview .....	38
11.2 Installation Procedure .....	39
11.2.1 Preparation Stage.....	39
11.2.2 Module Installation Stage .....	39
11.2.3 Communication Check(T.B.D).....	39
11.3 Preparation Stage—Procedure .....	40
11.4 Preparation Stage—Unpacking and move .....	40
11.5 Preparation Stage—Communication and Power wire. ....	41
11.5.1 Communication Wires.....	41
11.5.2 Power Wires (T.B.D) .....	41

# CONFIDENTIAL

11.6 Preparation Stage—Recommended Tools/Instruments .....	41
11.7 Preparation Stage—Appearance Inspection .....	42
11.7.1 Appearance Inspection for Module .....	42
11.8 Module Installation Stage .....	43
<b>(8) Check the LED Status: Refer the section .....</b>	<b>45</b>
<b>(13) Check the LED Status: Refer the section 8. LED Indication. ....</b>	<b>47</b>
11.9 Communication Check(T.B.D).....	47
<b>Contact Information.....</b>	<b>48</b>

CONFIDENTIAL

# CONFIDENTIAL

## Tables

Table 1: Acronyms and Abbreviations.....	7
Table 2 : Component Information.....	8
Table 3 : Safety Symbols.....	9
Table 4: General Specification.....	13
Table 5 : Connector information.....	16
Table 6 : Protocol ID Dip Switch Configuration.....	19
Table 7 : Detailed Method of Protocol ID Setting.....	19
Table 8 : Detailed CAN Communication.....	20
Table 9 : Detailed RS485 Communication.....	23
Table 10 : Protection Specification.....	28
Table 11 : Protection Control.....	31
Table 12 : Save data and period.....	32
Table 13 : SOC Indicator.....	33
Table 14 : Indicated error codes.....	33
Table 15 : ID Dip switch configuration.....	34
Table 16 : Detailed Method of Module ID Setting.....	35
Table 17: Recommended Tools and Instruments.....	41
Table 18 : Module Voltage and Internal Impedance.....	43

TEMPORARY

# CONFIDENTIAL

## Figures

Figure 1: Module Assembly.....	8
Figure 2: Storage Guide.....	12
Figure 3 : Module Drawing.....	14
Figure 4 : Module Front Structure.....	14
Figure 5 : Connector Naming .....	16
Figure 6 : External LED Circuit .....	17
Figure 7 : Dry Contact Circuit .....	17
Figure 8 : ON/OFF SWITCH Circuit.....	18
Figure 9 : Protocol ID Switch .....	19
Figure 10 : CAN ID Switch.....	34
Figure 11 : Module Drawings .....	37
Figure 12 : Fully installed ESS configuration.....	38
Figure 13 : Single Module configuration .....	39
Figure 14 : Installation Procedure .....	39
Figure 15 : Hold the module .....	40
Figure 16 : Signal connector type.....	41
Figure 17 : Check the Module voltage .....	42
Figure 18 : Location of ID Dip-switch .....	42
Figure 19 : Power on switch .....	42
Figure 20 : Check the Module voltage .....	43
Figure 21 : CAN ID Setting .....	43
Figure 22 : Location of TR switch .....	44
Figure 23 : Signal connector type.....	44
Figure 24 : Signal cable connection.....	44
Figure 25 : Turn on system .....	45
Figure 26 : Turn off system.....	46
Figure 27 : Power cable connection.....	46

# CONFIDENTIAL

## Acronyms and Abbreviations

The following acronyms and abbreviations are used in this manual.

**Table 1: Acronyms and Abbreviations**

Abbreviations	Full Name
BMS	Battery Management System
ESS	Energy Storage System
OTP	Over Temperature Protection
OVP	Over Voltage Protection
TR	Termination Resistor
SOC	State Of Charge
SOH	State Of Health
UTP	Under Temperature Protection
UVP	Under Voltage Protection
PCS	Power Conditioning System
RT	Room Temperature
Deg	Degree
OCP	Over Current Protection

Product No.	ELPM482-00005	Revision	0.2
-------------	---------------	----------	-----

# CONFIDENTIAL

## 1. Product Overview

Customer: Vertiv  
Product Number: ELPM482-00005  
Product Name: 4.84kWh Lithium Ion Energy Storage System  
Supplier: Samsung SDI Co., Ltd.

### 1.1 Scope

This document details the safety and handling information, characteristics, requirements, installation instructions, operating guidelines, service, maintenance and warranty of Lithium Ion Energy Storage System (“ESS” hereinafter) manufactured by Samsung SDI Co., Ltd. For **Vertiv**. It is intended to provide certified personnel and users with information on safe handling, installation and usage of the specified product.

This product is comprised of the following components. Refer to specification documents of each component for detailed information.

**Table 2 : Component Information**

Component	Product No.	Serial No.
Module Assembly	ELPM482-00005	TBD

### 1.2 Product Description

4.84kWh module is composed of 14S1P by using 94Ah cell and BMS is included. Main functions of BMS are measurement of the cell voltage, temperature, current and calculation of SOC, SOH and Protection the abnormal conditions and communication to PCS.

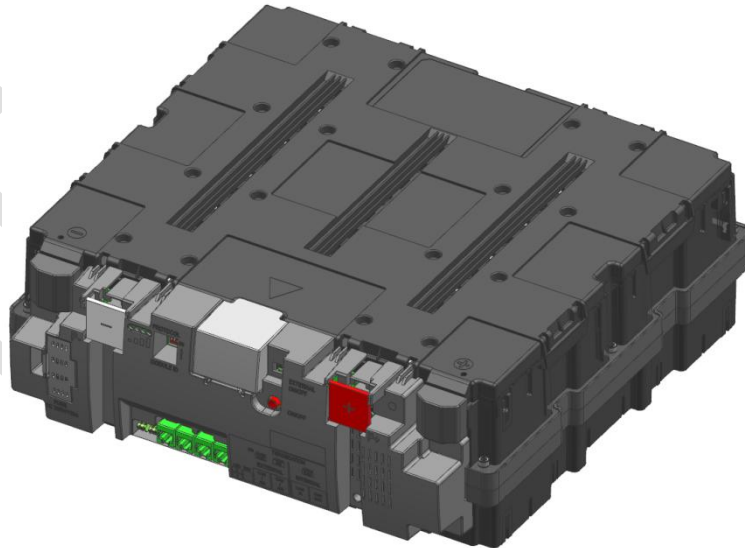

**Figure 1: Module Assembly**











# CONFIDENTIAL

## 2. Safety Information and Handling





This Part details the safety information that personnel must fully understand and follow while transporting, storing, installing, operating or servicing the ESS. Before proceeding with unloading, unpacking, handling, installation and operation, read the following details.

### 2.1 Safety Symbols

Table 3 : Safety Symbols

 <b>DANGER</b>	<p><b>DANGER</b></p> <p>'DANGER' indicates a hazardous situation which will result in death or serious injury if not avoided.</p>
 <b>WARNING</b>	<p><b>WARNING</b></p> <p>'WARNING' indicates a hazardous situation which could result in death or serious injury if not avoided.</p>
 <b>CAUTION</b>	<p><b>CAUTION</b></p> <p>'CAUTION' indicates a hazardous situation which could result in minor or moderate injury if not avoided.</p>
 <b>NOTICE</b>	<p><b>NOTICE</b></p> <p>'NOTICE' indicates a hazardous situation which could result in property damage if not avoided.</p>
	<p><b>Energy Storage Device</b></p> <p>To help avoid burns or electric shock :</p> <ul style="list-style-type: none"> <li>- Service by qualified personnel only</li> <li>- Disconnect main power before maintenance</li> <li>- Turn off the Battery System before maintenance</li> </ul>
	<p><b>Electric shock hazard</b></p> <p>Do not remove cover or disassemble.</p>
	<p><b>Explosive gas</b></p> <p>Do not expose to flame, incinerate, puncture, or impact</p>
	<p><b>Shield eyes</b></p> <p>Wear safety goggles at ALL times. (Installation, maintenance, etc.)</p>
	<p><b>Electrolyte hazard</b></p> <p>Do not contact eyes, skin or clothing. If it happens, Flush with water and seek medical aid immediately.</p>

# CONFIDENTIAL

	<p><b>Do not dispose in trash</b>          Transport legally. Follow manufacturer's instructions for disposal. Please recycle Lithium ion battery. Do not discard.</p>
	<p>Qualified technicians use this manual for service and replacement.</p>
	<p>This symbol is attached to the position near the DC+, DC- and communication port. If the user wants to access to the points near this symbol, he has to be fully aware of the contents in this manual.</p>
	<p>This symbol is near to the point for grounding. Wire for grounding has to be connected to the point with this symbol.</p>

## 2.2 General Safety Information

ESS provides a safe source of electrical energy when operated as intended and as designed. Potentially hazardous circumstances such as excessive heat or electrolyte mist may occur under improper operating conditions, damage, misuse and/or abuse. The following safety precautions and the warning messages described in this Part must be observed.

If any of the following precautions are not fully understood, or if you have any questions, contact Customer Support for guidance. The Safety Part may not include all regulations for your locale; personnel working with ESS must review applicable federal, state and local regulations as well as the industry standards regarding this product.

### 2.2.1 Protective Equipment

When working with ESS, the following personal protective equipment must be worn:

- High voltage rated rubber gloves
- Safety goggles or other eye protection

### 2.2.2 Organic Solvent Electrolyte

Cell components of ESS contain organic solvent-based electrolyte. Breach of individual cells may allow some electrolyte to be released from the cell. Direct contact with the liquid electrolyte can cause skin irritation.

If contact with the liquid electrolyte occurs, follow the suggestions below to minimize the chance of injury:

- Flush eyes immediately with cold running water for at least 15 minutes.
- Rinse skin immediately with water for at least 15 minutes.
- Remove clothing if soiled.

# CONFIDENTIAL

- Seek immediate medical attention.
- ### 2.2.3 Electrolyte Vent Product

The Lithium-Ion chemistry used in ESS contains an organic solvent-based electrolyte. If ESS is misused, damaged or abused, internal cell pressure may increase to excessive levels. Each cell within the ESS is equipped with a non-resettable vent so that if internal cell pressure increases, the cell's vent will activate releasing the electrolyte vent products. When operated as intended and designed, internal cell pressure remains stable and no electrolyte product venting occurs. Other structure (rack, enclosure e.g.) must not interfere gas vent.

Organic solvent electrolyte vent products are flammable. To avoid serious injury from the release and ignition of flammable products, the following guidelines must be observed:

- Operate the ESS under conditions only as specified in this manual.
- Keep sparks, flames and smoking materials away from the ESS.
- Do not incinerate, puncture or impact the ESS.
- Do not solder or weld to the ESS.

### 2.2.4 High Voltage Sources



**DANGER: HIGH VOLTAGE – ELECTRIC SHOCK HAZARD.** ESS does not include the enclosure. As all Battery Modules and wires are exposed, the probability of electric shock is high. ESS contains high voltage electric shock sources. Do NOT open any cover of Battery Module.

Exposure to high voltage can cause serious electrical burns, shock or death. To avoid high voltage electrical shock, follow the guidelines below:

- Do not work with high voltages unless you are qualified personnel.
- Personnel must fully understand the safety precautions associated with working on high voltage circuits.
- Personnel must fully understand the risk of working with batteries, and be prepared and equipped to take the necessary safety precautions.
- Necessary equipment, including but not limited to insulated tools, high voltage rated rubber gloves, rubber aprons, safety goggles, and face protection must be used.
- Ensure that the system is powered off and disconnected from outside circuits before servicing the unit.

### 2.2.5 Unloading and Unpacking

Carefully remove the plastic cover from the pallet. The packages are situated on a pallet on which it can be transported via forklift from location to location.

A damaged box or rattles during transport may indicate rough handling. Make a descriptive notation on the delivery receipt before signing. If damage is found, request an inspection by the carrier and file a damage claim. Pay particular attention to a damaged crate or staining from electrolyte or other fluids. Delay in notifying carrier may result in the loss of reimbursement for damages.

# CONFIDENTIAL

## 2.2.6 Storage

Follow the guidelines below when storing the Battery Modules.

- The battery module box should be upright as in Figure 2 below. Do not stack or place upside down when storing the battery module box.

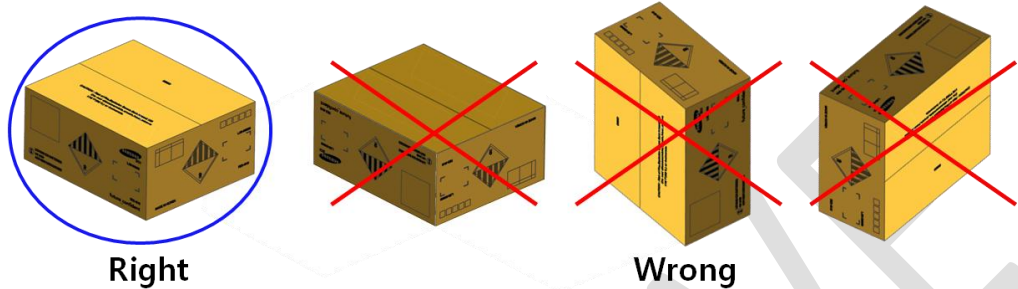

Figure 2: Storage Guide

- Do not stack more than five Battery Module boxes.
- Storage temperature must be in the range of -20 to 60°C.
- Storage humidity must be less than 85% RH under no condensing.
- Capacity degradation will occur depending on storage time.

To minimize capacity degradation, storage temperature should be controlled 25°C

## 2.3 General Handling Information

Follow the guidelines below when handling the ESS.

- Do not short circuit the positive (+) and negative (-) terminals with metallic object intentionally.
- Do not remove insulation cap on the terminals. If insulation cap is removed, avoid contacting between the metals and the battery terminals. Do not damage the screw thread.
- Do not use seriously scarred or deformed battery. Dispose them immediately according to proper regulations.
- Do not damage sheath of cable and connectors.

# CONFIDENTIAL

## 3. Module Specification(T.B.D)

Table 4: General Specification

No.	Item	Specification	Remarks
1	Dimension[mm]	446 x 440 x 158.2	
2	Weight[kg]	About 34.5	
3	Minimum Capacity	94Ah	1/3C (31A) charge and discharge @R.T
4	Cell Configuration	14S1P	
5	Nominal Capacity	4.84kWh	1/3C @R.T
6	Nominal Voltage <sup>1</sup>	51.52V DC	3.68V/cell
7	Maximum Voltage <sup>1</sup>	58.1V DC	4.15V/cell
8	End of Discharge Voltage <sup>1</sup>	44.8V DC	3.2V/cell
	Standard Discharging Current	31A	1/3C@R.T
	Maximum Discharging Current <sup>2</sup>	47A 40A 25A	Cell Temperature -10 to 30 °C 30 to 40 °C 40 to 50 °C
9	Charging Method	CC-CV	
	Charging Voltage <sup>1</sup>	58.1V DC	4.15V/cell
	Standard Charging Current	31A	1/3C @R.T
	Maximum Charging Current <sup>2</sup>	5A 13A 24A 35A 47A 40A 20A	Cell Temperature -10 to 0 °C 0 to 5 °C 5 to 10 °C 10 to 15 °C 15 to 30 °C 30 to 40 °C 40 to 50 °C
10	Cell Temperature Maximum Range	-10 ~ 50 °C	
11	Recommended Operation Temperature	23±5°C	Ambient Temperature
12	Storage Temperature	-20 ~ 60°C	
13	Storage Humidity	Less than 85 % RH	No condensing
14	Storage Period <sup>3</sup>	Less than 6 months	
15	External Communication	CAN	2.0A, 500kbps
		RS485	
16	Scalable Capacity	4.84 ~ 116.16kWh	14S1P ~ 14S24P

<sup>1</sup> Specified voltage must be satisfied in all load and charging conditions.

<sup>2</sup> Max current are changed according to temperature.

<sup>3</sup> The Capacity degradation will occur depending on storage time.

- To minimize capacity degradation, storage temperature should be controlled 25°C.



CAUTION

**Caution:** If the recommended charge and discharge current specification for the temperature is not followed, cell life cycle degradation may be accelerated. Also, if the system is used at above the recommended current at a high temperature status, ESS operation can be stopped by protection.



WARNING

**Warning:** If the Module voltage is lower than 44.8V by the long term storage, system operation stop, and long term Commissioning, we strongly

# CONFIDENTIAL

recommend recharge the module. If not, the degradation of cell cycle life can be accelerated. Also if the module voltage was being discharged deeper than 21V, it will be irrevocably damaged, resulting in a permanent failure. In case the module cannot be charged such as long-term storage, standing by for Commissioning, and long-term system stop, it is recommended that turned off the module.

## 4. Product Structure and Block Diagram

### 4.1 Product structure

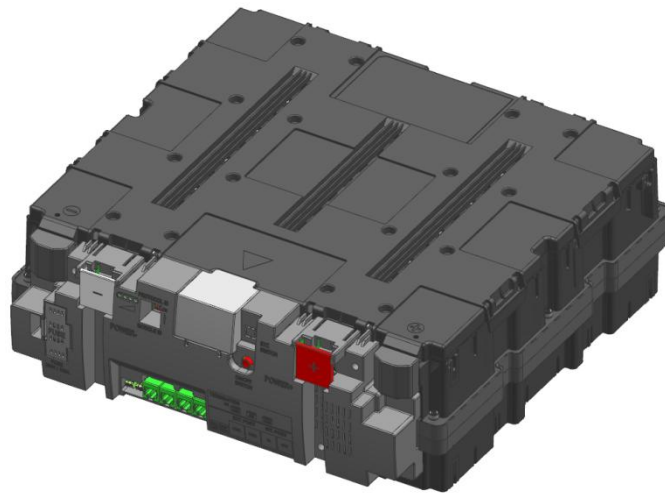

Figure 3 : Module Drawing

### 4.2 Front View

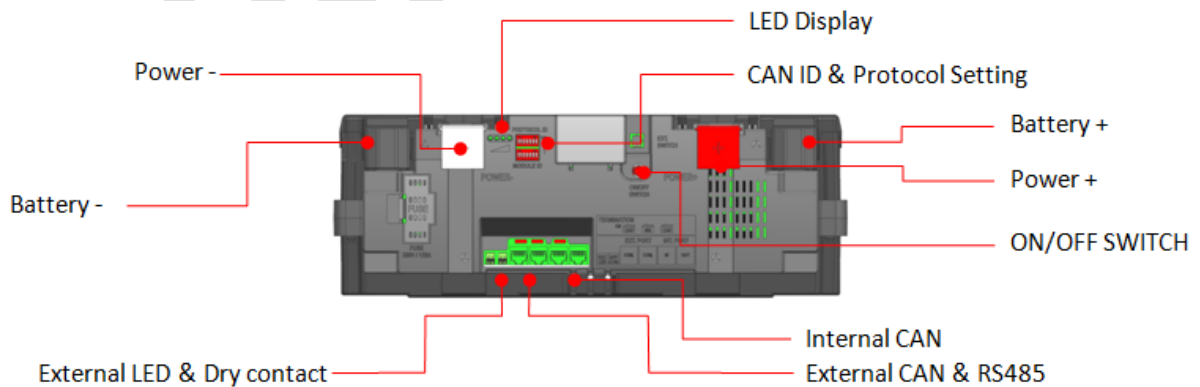
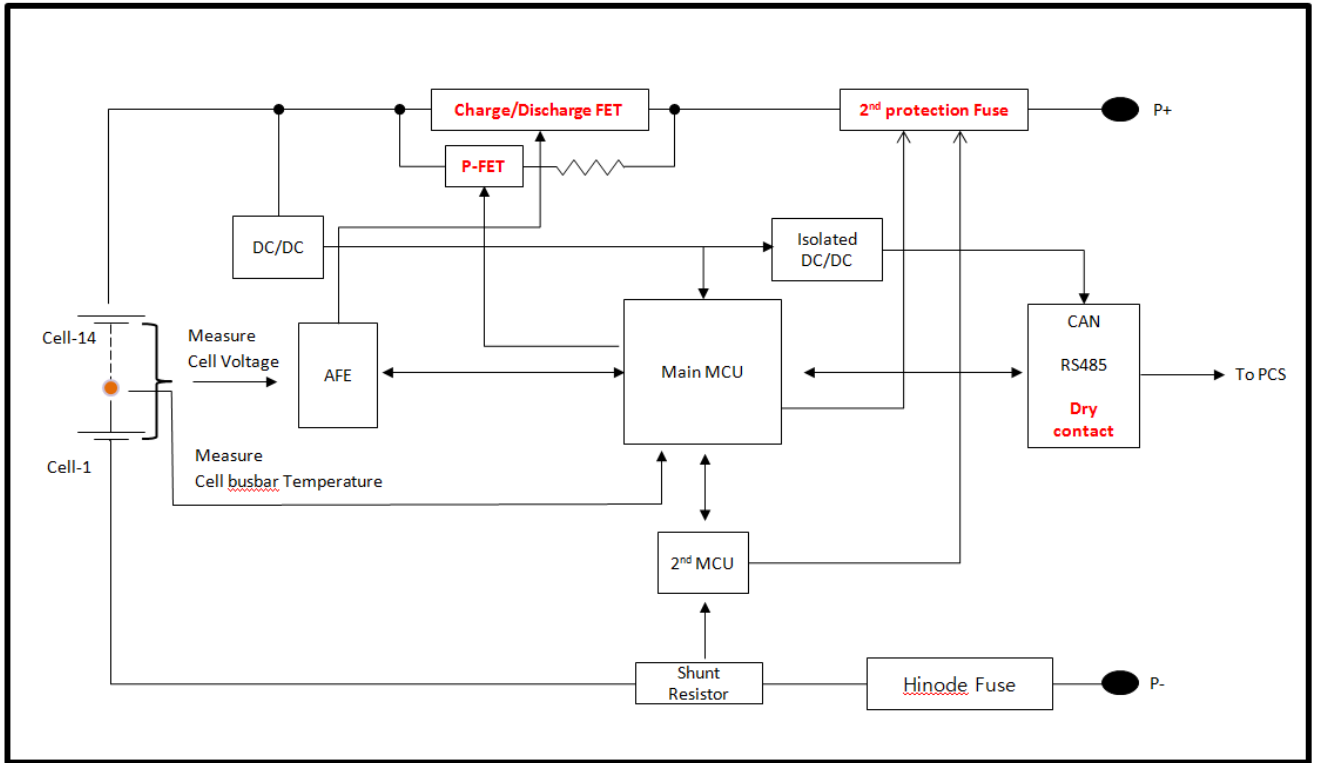

Figure 4 : Module Front Structure

# CONFIDENTIAL

## 4.3 BMS block diagram



## 4.4 BMS Key components

Item	Key components	Spec
MCU	STM32F105VCT6	-
Current Sensing IC	R2A24060	-
AFE	ML5236	14Ch
Shunt Resistor	PSR500HTQFH1L00	1mΩ, 1%, 5W, 2 Parallel
2nd protection fuse	BZ05-640	75A, 64Ω
FET	FDB019N807L	Rated 270A, 80Vdc 5 Parallel
Fuse	250GH-63UL	250V, 63A

**CONFIDENTIAL**

## 5. Connector Configuration

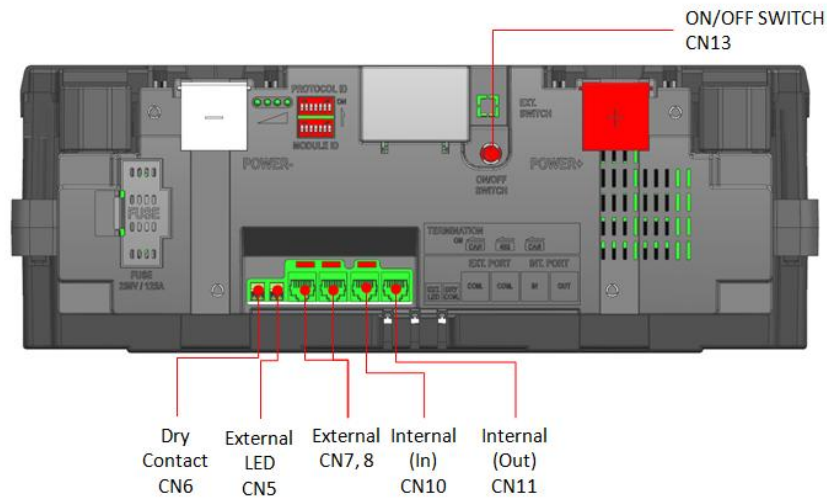
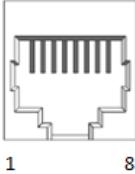
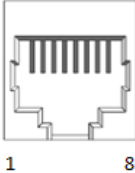
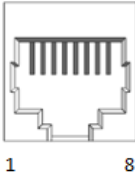



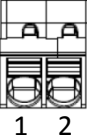

Figure 5 : Connector Naming

Table 5 : Connector information

No	NAME	Start point		
		Housing	Pin No	Pin Map
CN7 CN8	External Communication (CAN, RS485)		1	CAN2_H
			2	CAN2_L
			3	GND_CAN
			4	-
			5	RS485 +
			6	RS485 -
			7	RS485 -
			8	RS485 +
CN10	Internal Communication (Input, CAN)		1	CAN1_H
			2	CAN1_L
			3	GND_CAN
			4	-
			5	WAKE UP_IN
			6	-
			7	-
			8	-
CN11	Internal Communication (Output, CAN)		1	CAN1_H
			2	CAN1_L
			3	GND_CAN
			4	-
			5	WAKE UP_OUT
			6	-
			7	-
			8	-
CN5	External LED		1	Contact1



# CONFIDENTIAL

		1 2	2	Contact 2
CN6	Dry Contact		1	Contact1
			2	Contact 2
CN13	ON/OFF SWITCH		1	V <sub>BATT</sub>
			2	GND

## 5.1 Dry Contact, External LED Specification

### 1) External LED

- 1 channels, Coil driving specification: 5VDC/10mA max
- Normal operating: LED ON, Alarm/Protection: LED Toggle

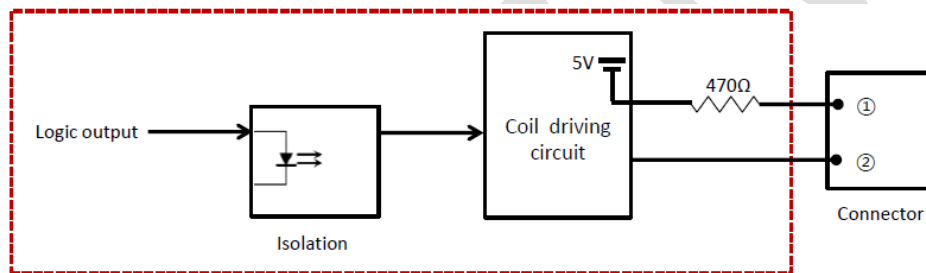

Figure 6 : External LED Circuit

### 2) Dry contact

- Output: 1 channels, Contact specification: 30VDC/1A max
- Normal operating: short, Alarm/Protection: Open

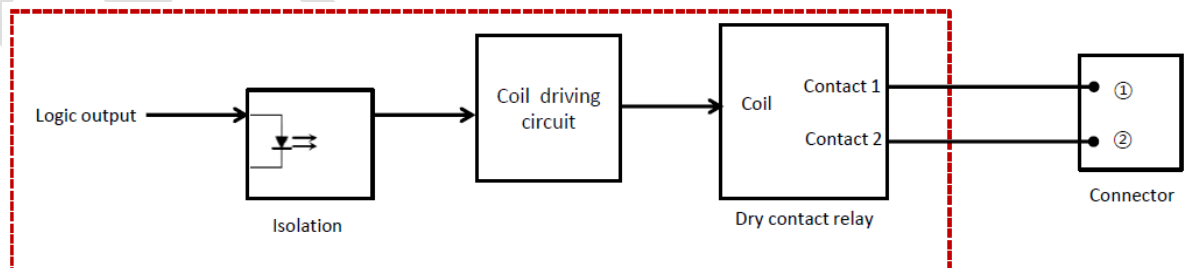

Figure 7 : Dry Contact Circuit

## 5.2 External connecting ON/OFF push switch Specification

### - Switch requirements

- . Must use push button type

## CONFIDENTIAL

- . Contact specification: 60VDC ↑, 100mA ↑
  - . Withstanding voltage: 1,000 VAC ↑
- Operating Sequence

- . Power ON: Push "ON/OFF SWITCH" on module of CAN ID '1' for more than 2 seconds.
- . Power OFF: Push "ON/OFF SWITCH" on CAN ID '1' for more than 5 seconds



CAUTION

**Caution:** Do not press the power switch button for more than 5 seconds during power on status. Module power is turned off if it is pressed for more than 5 seconds.

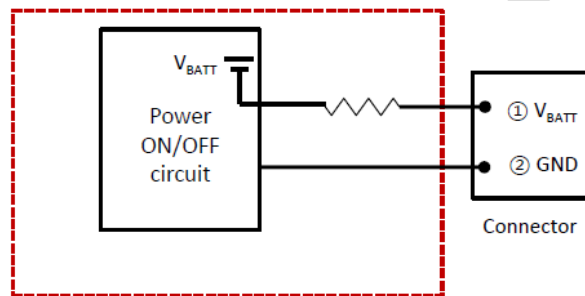

Figure 8 : ON/OFF SWITCH Circuit

# CONFIDENTIAL

## 6. Protocol

### 6.1 Protocol ID Set Dip switch configuration

Protocol ID Dip-switch's configuration is as follow.



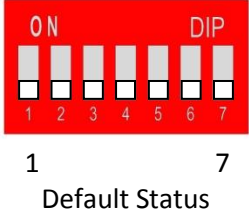

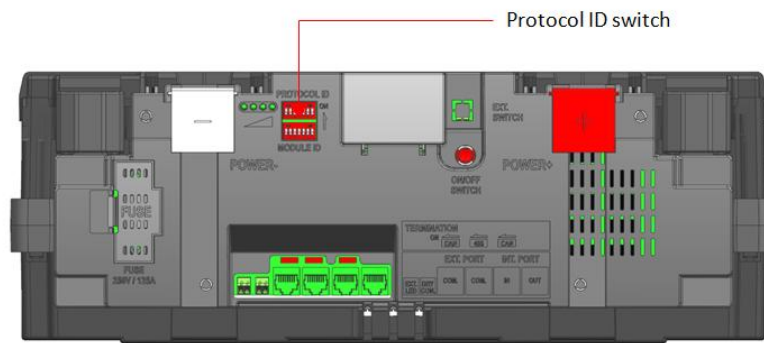

**Table 6 : Protocol ID Dip Switch Configuration**

ID Dip-Switch	Switch No	Functions
	1	Protocol ID Bit 1
	2	Protocol ID Bit 2
	3	Protocol ID Bit 3
	4	Protocol ID Bit 4
	5	Protocol ID Bit 5
	6	Protocol ID Bit 6
	7	Protocol ID Bit 7

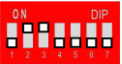





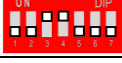
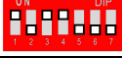
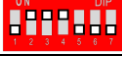

**Figure 9 : Protocol ID Switch**

**Table 7 : Detailed Method of Protocol ID Setting**

Protocol Configuration		CAN Protocol	MODBUS Protocol	
Decimal	Switch	Frame Format	Baud rate(bps)	Parity Bit
0		Standard	9600	Even
1		Extended		Odd
2		Standard		None
3		Extended	19200	Even
4		Standard		Odd
5		Extended		None

# CONFIDENTIAL

6		Standard	38400	Even
7		Extended		Odd
8		Standard		None
9		Extended	57600	Even
10		Standard		Odd
11		Extended		None
12		Standard	115200	Even
13		Extended		Odd
14		Standard		None

## 6.2 Module to PCS CAN Communication

- Baud rate: 500kbps
- Format: CAN2.0A 11 bit identifier
- Data Length: 8byte
- CAN data is transmitted with encoding in little endian – low byte first – unless stated otherwise.
- Broadcasting period: 500ms

**Table 8 : Detailed CAN Communication**

CAN ID	Byte	Bit	Name	Data type	Scale	Uint	Min	Max	Description
0x500	0		System Voltage	U16	0.01	V			Average tray voltage in normal trays * normal tray : Charge/Discharge FET On
0x500	2		System Current	S16	1	A			Total current in all tray (Battery Charge : +, Battery Discharge : -)
0x500	4		System SOC	U8	1	%	0	100	Average SOC in all tray
0x500	5		System SOH	U8	1	%	0	100	Average SOH in all tray
0x500	6		System Heart-Beat	U16	1	Dec	0	60000	Heart-Beat Value
0x501	0	0	System Alarm Status	Bit			0	1	Over-Voltage Alarm
	0	1		Bit			0	1	Under-Voltage Alarm
	0	2		Bit			0	1	Over-Temperature Alarm
	0	3		Bit			0	1	Under-Temperature Alarm
	0	4		Bit			0	1	Charge Over-Current Alarm
	0	5		Bit			0	1	Discharge Over-Current Alarm
	0	6		Bit			0	1	FET Over-Temperature Alarm
	0	7		Bit			0	1	Tray Voltage Imbalance Alarm
	1	0		Bit			0	1	-
	1	1		Bit			0	1	-
	1	2		Bit			0	1	-
	1	3		Bit			0	1	-
	1	4		Bit			0	1	-
	1	5		Bit			0	1	-
1	6	Bit			0	1	-		
1	7	Bit			0	1	-		

# CONFIDENTIAL

0x501	2	0	System Protection Status	Bit			0	1	Over-Voltage Protection
	2	1		Bit			0	1	Under-Voltage Protection
	2	2		Bit			0	1	Over-Temperature Protection
	2	3		Bit			0	1	-
	2	4		Bit			0	1	Charge Over-Current Protection
	2	5		Bit			0	1	Discharge Over-Current Protection
	2	6		Bit			0	1	FET Over-Temperature Protection
	2	7		Bit			0	1	-
	3	0		Bit			0	1	Tray-ID Error Protection
	3	1		Bit			0	1	PCS Comm. Error Protection
	3	2		Bit			0	1	FET Failure
	3	3		Bit			0	1	FET Over-Temperature Failure
	3	4		Bit			0	1	Under-Voltage Shutdown
	3	5		Bit			0	1	Cell Voltage Imbalance Protection
3	6	Bit			0	1	2nd Over-Voltage Protection		
3	7	Bit			0	1	-		
0x501	4		Number of total trays	U8	1	EA	1	39	Number of Total Tray
	5		Number of normal operating trays	U8	1	EA			Number of Normal Operating Tray
	6		Number of fault trays	U8	1	EA			Number of Fault Tray
	7		Reserved	U8					-
0x502	0		Battery Charge Voltage	U16	0.1	V			Set point for battery charge voltage
	2		Charge Current Limitation	U16	0.1	A	0	1833	DC charge current limitation
	4		Discharge Current Limitation	U16	0.1	A	0	2145	DC discharge current limitation
	6		Battery Discharge Voltage	U16	0.1	V			Voltage discharge limit
0x503	0		System Avg. Cell Voltage	U16	0.001	V			Average cell voltage in all tray
	2		System Max. Cell Voltage	U16	0.001	V			Maximum cell voltage in all tray
	4		System Min. Cell Voltage	U16	0.001	V			Minimum cell voltage in all tray
	6		System Avg. Tray Voltage	U16	0.01	V			Average tray voltage in all tray
0x504	0		System Max. Tray Voltage	U16	0.01	V			Maximum tray voltage in all tray
	2		System Min. Tray Voltage	U16	0.01	V			Minimum tray voltage in all tray
	4		System Avg. Cell Temperature	S8	1	°C			Average cell temperature in all tray
	5		System Max. Cell Temperature	S8	1	°C			Maximum cell temperature in all tray
	6		System Min. Cell Temperature	S8	1	°C			Minimum cell temperature in all tray
7		Reserved	U8					-	
0x505	0		Comm. Protocol Version(Major)	U8	1	Dec	0	255	Communication Protocol Version(Major)
	1		Comm. Protocol Version(Minor)	U8	1	Dec	0	255	Communication Protocol Version(Minor)
	2		Reserved	U8					-
	3		Reserved	U8					-
	4		Reserved	U8					-
	5		Reserved	U8					-
	6		Reserved	U8					-
7		Reserved	U8					-	
0x510 ~0x55C	0		Tray#n Voltage	U16	0.01	V			
	2		Tray#n Current	S16	0.01	A			(Battery Charge : +, Battery Discharge : -)
	3		Tray#n SOC	U8	1	%	0	100	
	4		Tray#n SOH	U8	1	%	0	100	
	6		Tray#n Alarm Status	U16	1				Refer to the System Alarm Status Bit
0x510: #1, 0x514: #2, 0x518: #3, 0x51C: #4, 0x520: #5, 0x524: #6, 0x528: #7, 0x52C: #8, 0x530: #9, 0x534: #10, 0x538: #11, 0x53C: #12, 0x540: #13, 0x544: #14, 0x548: #15, 0x54C: #16, 0x550: #17, 0x554: #18, 0x558: #19, 0x55C: #20									
0x511 ~0x55D	0		Tray#n Protection Status	U16	1				Refer to the System Protection Status Bit
	2		Tray#n Max. Cell Voltage	U16	0.001	V			
	4		Tray#n Min. Cell Voltage	U16	0.001	V			
	6		Tray#n Max. Cell Temperature	S8	1	°C			
	7		Tray#n Min. Cell Temperature	S8	1	°C			
0x511: #1, 0x515: #2, 0x519: #3, 0x51D: #4, 0x521: #5, 0x525: #6, 0x529: #7, 0x52D: #8, 0x531: #9, 0x535: #10, 0x5389: #11, 0x53D: #12, 0x541: #13, 0x545: #14, 0x549: #15, 0x54D: #16, 0x551: #17, 0x555: #18, 0x559: #19, 0x55D: #20									
0x5F0	0		Tray-ID	U16	1	ID	1	20	
	2		Cell Voltage #01	U16	0.001	V			
	4		Cell Voltage #02	U16	0.001	V			
	6		Cell Voltage #03	U16	0.001	V			
0x5F1	0		Tray-ID	U16	1	ID	1	20	
	2		Cell Voltage #04	U16	0.001	V			
	4		Cell Voltage #05	U16	0.001	V			
	6		Cell Voltage #06	U16	0.001	V			
0x5F2	0		Tray-ID	U16	1	ID	1	20	
	2		Cell Voltage #07	U16	0.001	V			
	4		Cell Voltage #08	U16	0.001	V			
	6		Cell Voltage #09	U16	0.001	V			

Product No.	ELPM482-00005	Revision	0.2
-------------	---------------	----------	-----

# CONFIDENTIAL

0x5F3	0	Tray-ID	U16	1	ID	1	20	
	2	Cell Voltage #10	U16	0.001	V			
	4	Cell Voltage #11	U16	0.001	V			
	6	Cell Voltage #12	U16	0.001	V			
0x5F4	0	Tray-ID	U16	1	ID	1	20	
	2	Cell Voltage #13	U16	0.001	V			
	4	Cell Voltage #14	U16	0.001	V			
	5	Reserved	U8					
	6	Reserved	U8					
	7	Reserved	U8					

TENTATIVE

# CONFIDENTIAL

## 6.3 Module to PCS RS485 Communication

- Baud rate: 9600bps, 19200bps, 38400bps, 57600bps, 115200bps
- Start-Bit: 1
- Data-Bit: 8
- Stop-Bit: 1
- Parity-Bit: Even / Odd / None

**Table 9 : Detailed RS485 Communication**

Function Code	Address (Hex)	Data	Description	Data Type	Scale	Unit	Data Definition															
							MSB								LSB							
0x04	0000	System Heart-beat	System Heart-beat value	U16	1	Dec	System Heart-beat															
0x04	0001	Comm. Protocol Version	LSB : Minor Version MSB : Major Version	U16	1	Dec	Major Version								Minor Version							
0x04	0002	System Voltage	Average tray voltage in normal trays (normal tray : Charge/Discharge FET On)	U16	0.01	V	System Voltage															
0x04	0003	System Current	Total current in all tray (Battery Charge : +, Battery Discharge : -)	S16	1	A	System Current															
0x04	0004	System SOC	Average SOC in all tray	U16	1	%	System SOC															
0x04	0005	System SOH	Average SOH in all tray	U16	1	%	System SOH															
0x04	0006	System Alarm Status	Bit 0: Over-Voltage Bit 1: Under-Voltage Bit 2: Over-Temperature Bit 3: Under-Temperature Bit 4: Charge Over-Current Bit 5: Discharge Over-Current Bit 6: FET Over-Temperature Bit 7: Tray Voltage Imbalance Bit 8: Reserved Bit 9: Reserved Bit 10: Reserved Bit 11: Reserved Bit 12: Reserved Bit 13: Reserved Bit 14: Reserved Bit 15: Reserved	U16	1	Bit	Bit 15	Bit 14	Bit 13	Bit 12	Bit 11	Bit 10	Bit 9	Bit 8	Bit 7	Bit 6	Bit 5	Bit 4	Bit 3	Bit 2	Bit 1	Bit 0





Product No.	ELPM482-00005	Revision	0.2
-------------	---------------	----------	-----



# CONFIDENTIAL

0x04	0017	Minimum Cell Voltage	Minimum cell voltage in all tray	U16	1	mV	Minimum Cell Voltage															
0x04	0018	Minimum Cell Voltage Position	Tray-ID	U16	1	ID	Minimum Cell Voltage Position															
0x04	0019	Average Cell Temperature	Average cell temperature in all tray	U16	1	°C	Average Cell Temperature															
0x04	001A	Maximum Cell Temperature	Maximum cell temperature in all tray	U16	1	°C	Maximum Cell Temperature															
0x04	001B	Maximum Cell Temperature Position	Tray-ID	U16	1	ID	Maximum Cell Temperature Position															
0x04	001C	Minimum Cell Temperature	Minimum cell temperature in all tray	U16	1	°C	Minimum Cell Temperature															
0x04	001D	Minimum Cell Temperature Position	Tray-ID	U16	1	ID	Minimum Cell Temperature Position															
0x04	001E	Reserved	-																			
0x04	001F	Reserved	-																			
0x04	0020	Reserved	-																			
0x04	0021	Reserved	-																			
0x04	0022	Reserved	-																			
0x04	0023	Reserved	-																			
0x04	0024	Reserved	-																			
0x04	0025	Reserved	-																			
0x04	0026	Reserved	-																			
0x04	0027	Reserved	-																			
0x04	0064	Tray Heart-beat	Tray Heart-beat value	U16	1	Dec	Tray Heart-beat															
0x04	0065	Tray Voltage	Tray Voltage	U16	0.01	V	Tray Voltage															
0x04	0066	Cell Voltage Sum	Cell Voltage Sum	U16	0.01	V	Cell Voltage Sum															
0x04	0067	Tray Current	Tray Current (Battery Charge : +, Battery Discharge : -)	S16	0.01	A	Tray Current															
0x04	0068	Tray SOC	Tray SOC	U16	1	%	Tray SOC															
0x04	0069	Tray SOH	Tray SOH	U16	1	%	Tray SOH															





# CONFIDENTIAL

## 7. Protection

BMS Protection will be activated in detection condition, and be deactivated in release condition.

**Table 10 : Protection Specification**

	Item	Level	Protection Set					Release Set		Description	
			Condition	Sec	Prechg FET	Chg FET	Dch FET	2nd Fuse	Condition		Sec
Voltage	Cell Over Voltage	2nd Protection	(Renesas) Tray Voltage $\geq 60.2V$ Or Max Cell Voltage $\geq 4.3V$	10	OFF	OFF	OFF	Fusing	PF	-	Set MCCV/MDCV "0A" et Permanant Flag
		Dry contact	(MCU) Max Cell Voltage $\geq 4.3V$	5							
		Protection	Max Cell Voltage $\geq 4.23V$ or Tray Voltage $\geq 59.22V$	5	OFF	OFF	OFF	-	Power reset	-	Set MCCV "0A"
		Alarm	Max Cell Voltage $\geq 4.19V$ or Tray Voltage $\geq 58.66V$	3	OFF	ON	ON	-	Max Cell Voltage $< 4.16V$ and Tray Voltage $< 58.24V$	3	Set Protection Flag Set Alarm Flag
	Cell Under Voltage	Shutdown	Min Cell Voltage $\leq 2.9V$ and $-3A < \text{Current} < 1A$ or Tray Voltage $\leq 40.6V$ and $-3A < \text{Current} < 1A$	60	OFF	OFF	OFF	-	Power reset	-	Set Emergency Charge Request Set MDCV "0A" Set Protection Flag On FET Off Time, BMS will be Shutdown
			Min Cell Voltage $\leq 2.9V$ and Current $\leq -3A$ or Tray Voltage $\leq 40.6V$ and Current $\leq -3A$	20	OFF	OFF	OFF	-			
		Protection	Min Cell Voltage $\leq 2.5V$	3	OFF	OFF	OFF	-	Power reset	-	Set Emergency Charge Request Set MDCV "0A"Set Protection Flag
		Alarm	"Min Cell Voltage $\leq 2.95V$ Or Tray Voltage $\leq 41.3V$ "	1	OFF	ON	ON	-	Min Cell Voltage $> 3.1V$ and Tray Voltage $> 43.4V$	3	Set Emergency Charge Request Set MDCV "0A"Set Alarm Flag

# CONFIDENTIAL

	Item	Level	Protection Set					Release Set		Description	
			Condition	Sec	Prechg FET	Chg FET	Dch FET	2nd Fuse	Condition		Sec
	Tray Voltage Imbalance	Alarm	Median Tray Voltage - My Tray Voltage   ≥ 650mV	3	ON	OFF	OFF	-	Median Tray Voltage - My Tray Voltage   < 500mV	3	Set MCCV/MDCV "0A" Set Alarm Flag Precharge Resistor Temp ≥ 80°C [P-FET OFF] Precharge Resistor Temp ≤ 70°C [P-FET ON] *considering Voltage accuracy : 2%
	Cell Voltage Imbalance	2nd Protection	(Max Cell V ≥ 3.5V) & (Cell VΔ ≥ 300mV)	10	OFF	OFF	OFF	Fusing	PF	-	Set MCCV/MDCV "0A" Set Permanant Flag
		Dry contact	(Max Cell V ≥ 3.5V) & (Cell VΔ ≥ 300mV)	5	OFF	OFF	OFF			-	Set MCCV/MDCV "0A" Set Permanant Flag
		Protection	(Max Cell V ≥ 3.5V) & (Cell VΔ ≥ 200mV)	5	OFF	OFF	OFF		Power reset	-	Set MCCV/MDCV "0A" Set Protection Flag
		Alarm	(Max Cell V ≥ 3.5V) & (Cell VΔ ≥ 100mV)	5	OFF	ON	ON	-	(Max Cell V ≥ 3.5V) & (Cell VΔ < 50mV)	5	Set MCCV/MDCV "0A" Set Alarm Flag
Temp	Cell Over Temp	2nd Protection	Max Cell temp(°C) ≥ 70°C	10	OFF	OFF	OFF	Fusing	PF	-	Set MCCV/MDCV "0A" Set Permanant Flag
		Dry contact	Max Cell temp(°C) ≥ 70°C	5	OFF	OFF	OFF			-	Set MCCV/MDCV "0A" Permanant Flag Set
		Protection	Max Cell temp(°C) ≥ 65°C	5	OFF	OFF	OFF	-	Power reset	-	Set MCCV/MDCV "0A" Set Protection Flag
		Alarm	Max Cell temp(°C) ≥ 60°C	3	OFF	ON	ON	-	Max Cell temp(°C) < 55°C	3	Set MCCV/MDCV "0A" Set Alarm Flag
	Cell Under Temp	Alarm	Min Cell temp(°C) ≤ -15°C	3	OFF	ON	ON	-	Min Cell temp(°C) > -10°C	3	Set Alarm Flag
	FET Over Temp	Protection	FET temp(°C) ≥ 80°C	5	OFF	OFF	OFF	-	Power reset	-	Set MCCV/MDCV "0A" Set Protection Flag
	Alarm	FET temp(°C) ≥ 70°C	3	OFF	ON	ON	-	FET temp(°C) < 60°C	3	Set MCCV/MDCV "0A" Set Alarm Flag	

Product No.	ELPM482-00005	Revision	0.2
-------------	---------------	----------	-----



# CONFIDENTIAL

	Item	Level	Protection Set						Release Set		Description
			Condition	Sec	Prechg FET	Chg FET	Dch FET	2nd Fuse	Condition	Sec	
Current	Over Current	2nd Protection	$ Current  \geq 150A$	2	OFF	ON	ON	Fusing	PF	-	Set MCCV/MDCV "0A" Set Permanent Flag
		Protection	$150 >  Current  \geq 63A$	1	OFF	OFF	OFF	-	Power Reset	-	Set MCCV/MDCV "0A" Set Protection Flag
		Protection	$63A >  Current  \geq 55A$	3	OFF	OFF	OFF	-			
		Alarm	$ Current  \geq 52A$	3	OFF	ON	ON	-	Current < 47A	3	Set MCCV/MDCV "0A" Set Alarm Flag
Comm	Tray ID Error	Protection	Tray-ID collision	10	OFF	OFF	OFF	-	Setting the Tray-ID & Power Reset	-	Set MCCV/MDCV "0A" Set Protection Flag
H/W	AFE Error	Protection	Communication Fail or Cell Voltage Holding	30 3600	OFF	OFF	OFF	-	Power Reset	-	Set MCCV/MDCV "0A" Set Protection Flag
		Alarm	Communication Fail or Cell Voltage Holding	10 1800	OFF	ON	ON	-	Communication Success and Cell Voltage Not Holding	-	Set MCCV/MDCV "0A" Set Alarm Flag
	FET Failure	2nd Protection	$Charge\ FET\ open \& \ Discharge\ FET\ open\ and\ Current \geq 1A\ or\ Current \leq -1A$	10	OFF	OFF	OFF	Fusing	PF	-	Set MCCV/MDCV "0A" Set Protection Flag
		Dry contact		7	OFF	OFF	OFF	-			
Protection	5	OFF		OFF	OFF	-	Power Reset				
ToTal Protection Count		2nd Protection	Protecion Count $\geq 5$ & period(T.B.D)	10	OFF	OFF	OFF	Fusing	PF	-	
		Dry contact	Protecion Count $\geq 5$ & period(T.B.D)	5	OFF	OFF	OFF	-		-	

Product No.	ELPM482-00005	Revision	0.2
-------------	---------------	----------	-----

## CONFIDENTIAL

**Table 11 : Protection Control**

Rack BMS will send alarm and protection/Dry contact signal when there is a fault detected in the Battery System. The charger unit, the inverter unit or the PCS must control the battery unit accordingly if alarm and protection/Dry contact are detected by the Rack BMS.

Mode	RBMS	Action of PCS / inverter unit
2nd fusing	2nd protection fuse is open	2nd fusing Disconnect the Battery system by open the 2nd protection fuse in RBMS. SDI Servicing may be needed and should be changed RBMS.
Dry contact	BMS respond CAN dry-contact bit from PCS Fault request and the Dry-contact maintains Low(0V) signal.	Permanent Fault disconnect the battery system <b>by opening the DC relay or external disconnect switch.</b> DC relay or external disconnect switch should be controlled directly by dry-contact(CB AUX or relay power control) SDI Servicing may be needed.
Protection	BMS respond CAN Protection bit from PCS Fault request and the Dry-contact maintains High(5V, max 20mA) signal.	PCS should set the battery system <b>in idle mode(stop charge/discharge)</b> to prevent the fault from escalating to protection mode After the battery system be checked and reset the RBMS for operation.
Alarm	BMS respond CAN Alarm bit from PCS Fault request and the Dry-contact maintains High(5V, max 20mA) signal. If the alarm is cleared, the battery system can be used normally again.	Derating Power.

# CONFIDENTIAL

## 8. save data and period

PCS will be saved RS-485 data and daily log for guarantee life and safety of battery.

Table 12 : Save data and period

Function code	data list		period
	Address(Hex)		
0x04	0000 ~ 001D (System information)		Every 10minute
0x04	0064 ~ 0076 (Tray information)		
0x04	0077~0084		Every 1sec for 5minute before alarm/protection/dry-contact triggered
Daily log	Year Month Date Daily lowest SOC (%) Daily highest SOC (%) Daily highest charging power (mW) Daily highest discharging power (mW) Daily aggregated charging energy (mAh) Daily aggregated discharging energy (mAh) Daily standby time (minute) History (Timer counter)		Once a day (Assuming per daily log data and 10 years of operation)

\* History counter (current vs temperature)

	$0A \leq I < 3A$	$3A \leq I < 6A$	$6A \leq I < 9A$	$9A \leq I < 12A$	$12A \leq I < 15A$	$15A \leq I < 18A$	$18A \leq I < 20A$	$I \geq 20A$
T < -10°C								
-10°C ≤ T < 0°C								
0°C ≤ T < 10°C								
10°C ≤ T < 20°C								
20°C ≤ T < 30°C								
30°C ≤ T < 40°C								
40°C ≤ T < 50°C								
T ≥ 50°C								

\* History counter (standby voltage vs temperature)

	Avg Cell V < 3.0V	$3.0V \leq \text{Avg Cell V} < 3.2V$	$3.2V \leq \text{Avg Cell V} < 3.4V$	$3.4V \leq \text{Avg Cell V} < 3.6V$	$3.6V \leq \text{Avg Cell V} < 3.8V$	$3.8V \leq \text{Avg Cell V} < 4.0V$	$4.0V \leq \text{Avg Cell V} < 4.1V$	$4.1V \leq \text{Avg Cell V}$
T < -10°C								
-10°C ≤ T < 0°C								
0°C ≤ T < 10°C								
10°C ≤ T < 20°C								
20°C ≤ T < 30°C								
30°C ≤ T < 40°C								
40°C ≤ T < 50°C								
T ≥ 50°C								



# CONFIDENTIAL

## 8. LED Indication

### 8.1 Normal Status Display

At the normal operation state, the battery LED shows SOC level.

Table 13 : SOC Indicator

SOC	LED #1	LED #2	LED #3	LED #4	LED Ext
0% ~ 24%	On	Off	Off	Off	On
25% ~ 49%	On	On	Off	Off	On
50% ~74%	On	On	On	Off	On
75% ~ 100%	On	On	On	On	On

### 8.2 Error Status Display

If BMS detects alarm or protection conditions, the LEDs blink .

Table 14 : Indicated error codes

Status			LED #1	LED #2	LED #3	LED #4	LED Ext	Blink Type
2sec Toggle	1sec Toggle	500ms Toggle						
OV Alarm			Toggle	Off	Off	Off	Toggle	1
	OV Protection		Toggle	Off	Off	Off	Toggle	2
		OV Dry contact / 2nd	Toggle	Off	Off	Off	Toggle	3
UV Alarm			Off	Toggle	Off	Off	Toggle	4
	UV Protection		Off	Toggle	Off	Off	Toggle	5
OT Alarm			Toggle	Toggle	Off	Off	Toggle	6
	OT Protection		Toggle	Toggle	Off	Off	Toggle	7
		OT Dry contact / 2nd	Toggle	Toggle	Off	Off	Toggle	8
UT Alarm			Off	Off	Toggle	Off	Toggle	9
Charge-OC Alarm			Toggle	Off	Toggle	Off	Toggle	10
	Charge-OC Protection		Toggle	Off	Toggle	Off	Toggle	11
		OC Dry contact	Toggle	Off	Toggle	Off	Toggle	12
Discharge-OC Alarm			Off	Toggle	Toggle	Off	Toggle	13
	Discharge-OC Protection		Off	Toggle	Toggle	Off	Toggle	14
		OC Dry contact	Off	Toggle	Toggle	Off	Toggle	15
FET-OT Alarm			Toggle	Toggle	Toggle	Off	Toggle	16
	FET-OT Protection		Toggle	Toggle	Toggle	Off	Toggle	17
Tray Voltage alarm		-	Off	Off	Off	Toggle	Toggle	18
-	Tray-ID Error Protection		Toggle	Off	Off	Toggle	Toggle	19
AFE Error Alarm			Off	Toggle	Off	Toggle	Toggle	20
	AFE Error Protection		Off	Toggle	Off	Toggle	Toggle	21
-	FET Failure Protection		Toggle	Toggle	Off	Toggle	Toggle	22
		FET Dry contact / 2nd	Toggle	Toggle	Off	Toggle	Toggle	23
CVI Alarm		-	Off	Off	Toggle	Toggle	Toggle	24
	CVI Protection		Off	Off	Toggle	Toggle	Toggle	25
		CVI Dry contact / 2nd	Off	Off	Toggle	Toggle	Toggle	26

# CONFIDENTIAL

## 9. Module ID Dip Switch Configuration

ID Dip-switch's configuration is as follow. Module ID can be set with switch number from 1 to 6. Switch number 7 is only used in single Module mode. Switch number 7 is used to power on BMS.

Table 15 : ID Dip switch configuration

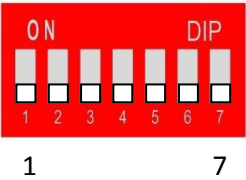
ID Dip-Switch	Switch No	Functions
 <p>1 7 Default Status</p>	1	Module ID Bit 1
	2	Module ID Bit 2
	3	Module ID Bit 3
	4	Module ID Bit 4
	5	Module ID Bit 5
	6	Module ID Bit 6
	7	BMS Power On/Off

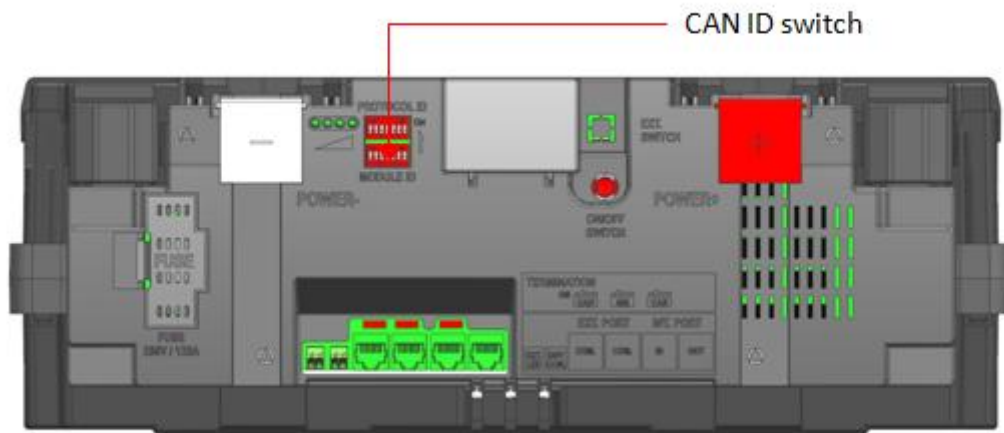

Figure 10 : CAN ID Switch

# CONFIDENTIAL

## 9.1 Module ID set

Module ID should be set before installation. ID can be set using dip-switch in front of Module. ID is composed of binary number from 0(0000001) to 19(1100101). Default set value is 0(0000001). The maximum number of the paralleled Module is 20. You must set different Module ID for each Module in the system. Module ID is basically set in increments of '1'.



**Caution:** Do not set the same Module ID in system. If there is same Module ID in the system, Module do not work.

CAUTION

**Table 16 : Detailed Method of Module ID Setting**

ID 1		ID 2		ID 3		ID 4	
	1 7 0000001		1 7 1000001		1 7 0100001		1 7 1100001
ID 5		ID 6		ID 7		ID 8	
	1 7 0010001		1 7 1010001		1 7 0110001		1 7 1110001
ID 9		ID 10		ID 11		ID 12	
	1 7 0001001		1 7 1001001		1 7 0101001		1 7 1101001
ID 13		ID 14		ID 15		ID 16	
	1 7 0011001		1 7 1011001		1 7 0111001		1 7 1111001
ID 17		ID 18		ID 19		ID 20	
	1 7 0000101		1 7 1000101		1 7 0100101		1 7 1100101
ID 21		ID 22		ID 23		ID 24	
	1 7 0010101		1 7 1010101		1 7 0110101		1 7 1110101



**CONFIDENTIAL**

**10. Drawings**

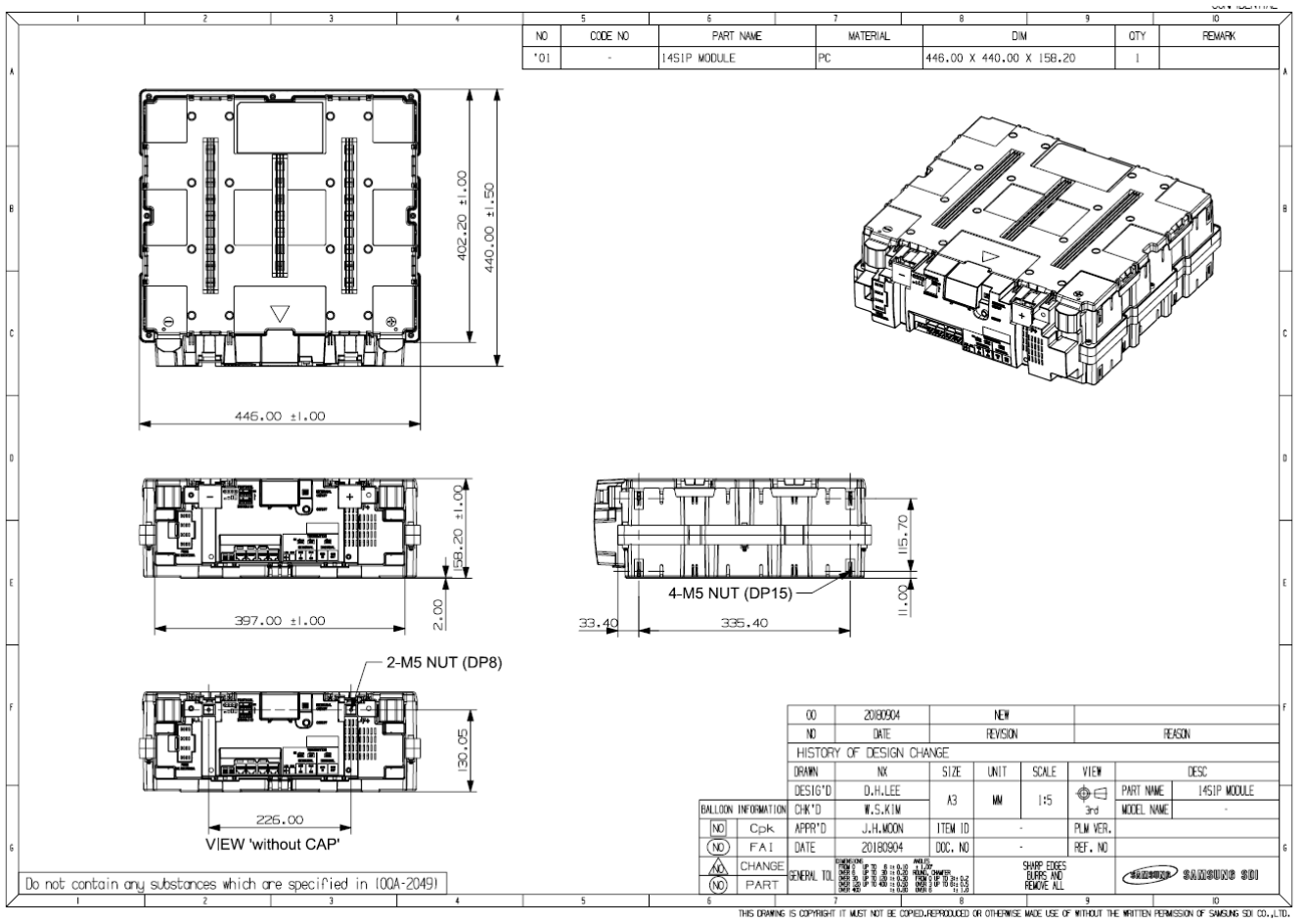

Figure 11 : Module Drawings

TEMP

# CONFIDENTIAL

## 11. Installation

### 11.1 Overview

This section provides detailed information on assembly and installation of ESS. Please be sure to read and fully understand installation manual documents before proceeding Installation. Fully installed ESS is shown as below in Figure 12.

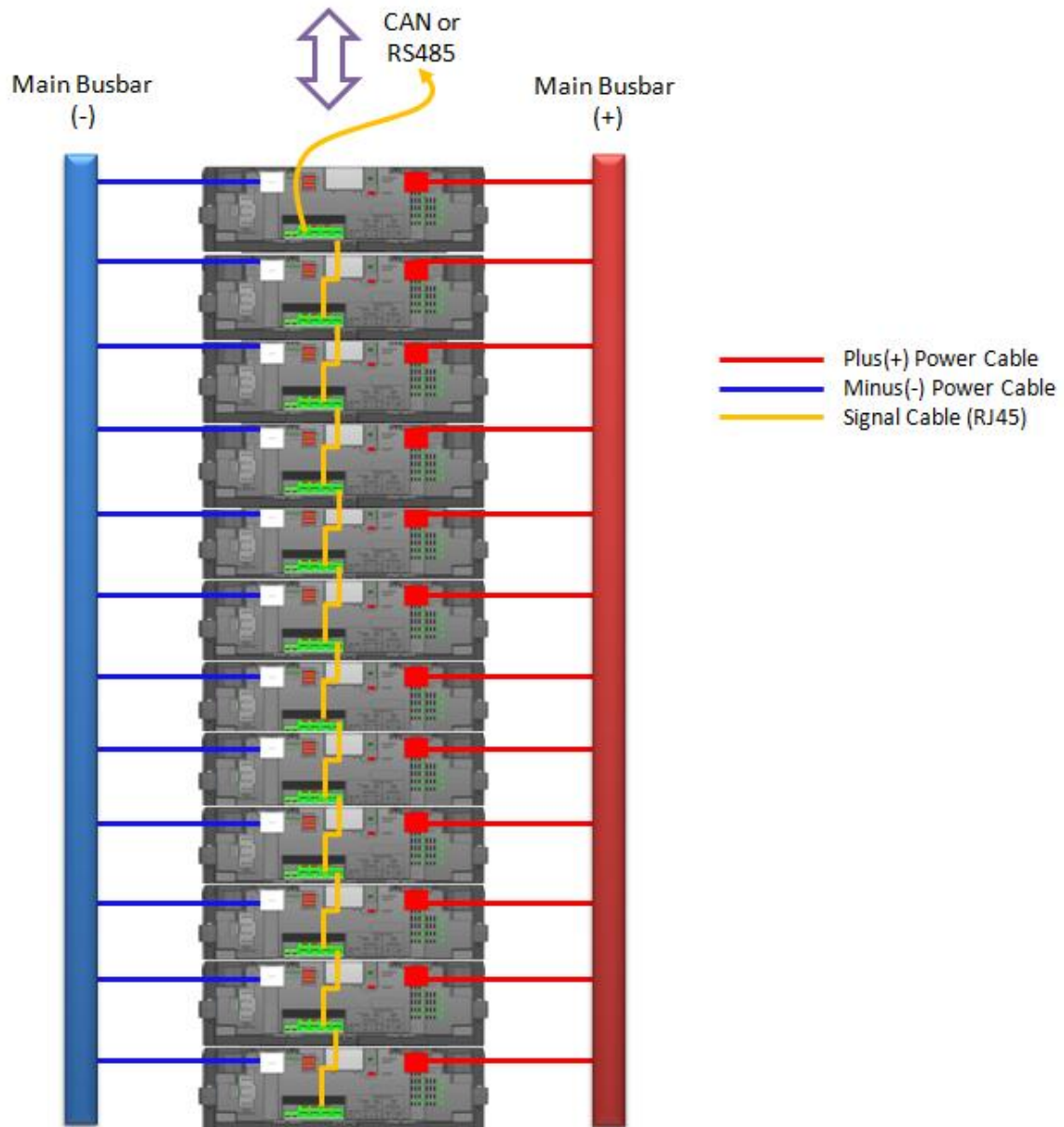

Figure 12 : Fully installed ESS configuration

# CONFIDENTIAL

Single Module configuration is shown below in Figure 13.

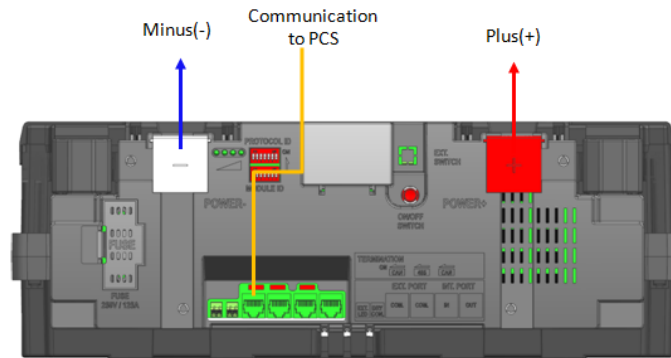

Figure 13 : Single Module configuration

## 11.2 Installation Procedure

This product must be installed by following the procedure below:

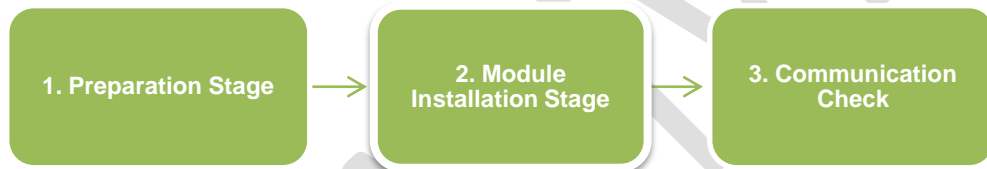

Figure 14 : Installation Procedure

### 11.2.1 Preparation Stage

- Procedure
- Unpacking
- Communication and Power Wire
- Recommended Tools/Instruments
- Appearance Inspection

### 11.2.2 Module Installation Stage

- Transport battery modules to the installation place.
- Place the battery modules on the rack frame.
- Measure the voltage of each module
- Setting the CAN ID
- Setting the Terminating Resistance
- Connection the Signal Wire
- Power on the Modules
- Check the LED Status
- Measure the voltage of each module.
- Power Off the modules
- Connecting the power cable
- Power on the Modules
- Check the LED Status

### 11.2.3 Communication Check(T.B.D)

# CONFIDENTIAL

## 11.3 Preparation Stage—Procedure

For the preparation stage, perform the following steps:

1. Create the installation plan and check the equipment units and instruments for installation.
2. Check the arrival schedule of the parts required.
3. Perform unpacking.
4. Perform the appearance inspection.

	<b>WARNING</b>
	<ul style="list-style-type: none"> <li>▪ Do not wear watches, rings, jewelry, or any other metal objects.</li> <li>▪ You shall wear electrically insulated gloves and safety shoes.</li> </ul>

	<b>CAUTION</b>
	<ul style="list-style-type: none"> <li>▪ Store the product in a dust-free place with the moisture level of below 85% and the temperature level of 23±5 °C.</li> <li>▪ Keep components out of direct sunlight.</li> </ul>

## 11.4 Preparation Stage—Unpacking and move

Check the following steps during unpacking.

1. Remove the box taping and remove the cushion in the box.
2. Hold the module side direction.

When you pick up the module holding the module front cover,

It is the possibility of separation from the module body and drop the module

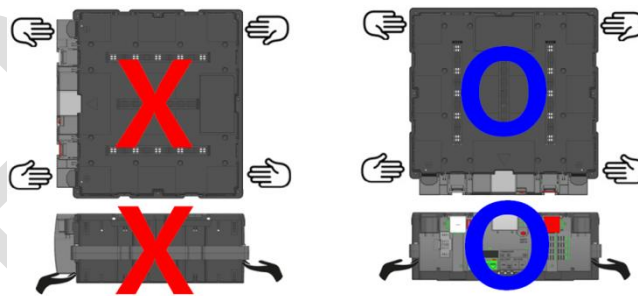



Figure 15 : Hold the module

3. Pick up the module with two people.
4. Transport the module into a workspace.

	<b>WARNING</b>
	<ul style="list-style-type: none"> <li>▪ When you pick up the module, you should hold the module side direction</li> </ul>



# CONFIDENTIAL

## 11.5 Preparation Stage—Communication and Power wire.

Communication and power wires are not provided by Samsung SDI, but must be provided by customer to use to racks. Customer-supplied Communication and power wires must adhere to the specifications below.

### 11.5.1 Communication Wires

Signal connectors use RJ-45 Type connector and Ethernet cable (above CAT-5 standard).

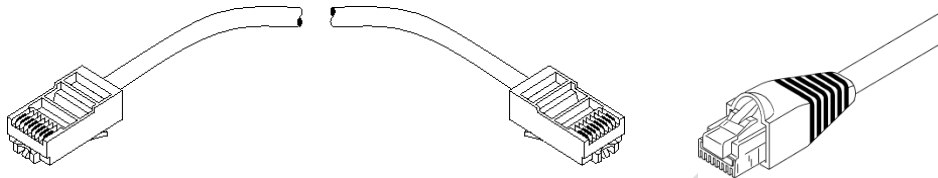

Figure 16 : Signal connector type





### 11.5.2 Power Wires (T.B.D)

Power lugs use Type lug and more than AWG 6 (above CAT-5 standard).

## 11.6 Preparation Stage—Recommended Tools/Instruments

The required tools and instruments are as follows:

Table 17: Recommended Tools and Instruments

No.	Items	Usage	Shape
1	Power Tool (Max torque: 26N.m/270 kgf.cm)	To fasten Power Cable (3.0 N.m / 30.5 kgf.cm)	
2	Phillips-head Tip	To fasten Power Cable (M6 Tip)	
3	Cutter Knife	Opening boxes	
4	Nipper	Cutting the Power Terminal Cover	
5	Battery Tester	Measure battery module's voltage and internal impedance (ref. HIOKI 3554)	

# CONFIDENTIAL

## 11.7 Preparation Stage—Appearance Inspection

During appearance inspection, the inspector should check the following cases:

	<b>CAUTION</b>
	<ul style="list-style-type: none"> <li>If there are any defects during the visual inspection, contact the SAMSUNG SDI customer service department.</li> </ul>

### 11.7.1 Appearance Inspection for Module

After transporting the module to the designated place, check the followings:

- Physical damage to the exterior
  - Paint peeling
  - Check if the screw is damaged or protruded
  - Check the voltage and internal impedance of the battery modules using the battery tester
  -
- 1) Check the Module Voltage: Confirm the Zero Voltage.



Figure 17 : Check the Module voltage

- 2) Switch number 7 of ID Dip Switch is set for BMS power on: Refer the Figure 18  
If Switch number 7 of ID Dip Switch is set, BMS is ready for Power on.

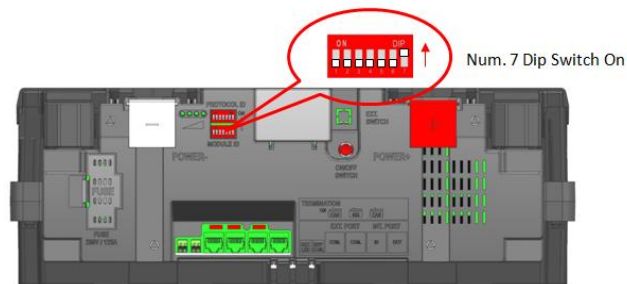

Figure 18 : Location of ID Dip-switch

- 3) Push “ON/OFF SWITCH” on any Module for more than 2 seconds.

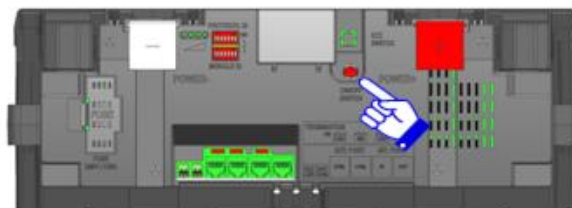

Figure 19 : Power on switch

# CONFIDENTIAL

- 4) Check the LED Status: Refer the section
- 5) Check the Module Voltage and Internal impedance.
- 6) Push "ON/OFF SWITCH" on any Module for more than 5 seconds
- 7) Check the LED OFF

**Table 18 : Module Voltage and Internal Impedance**

No.	Items	Value
1	Voltage Check	49.876 ~ 50.476V
2	Internal Impedance Check	9.9 ~ 12.1 mΩ

After completion, transport the module to the storage.

## 11.8 Module Installation Stage

- (1) Transport battery modules to the installation place.
- (2) Place the battery modules on the rack frame.
- (3) Measure the voltage of each module.  
Check the module voltage is 0V.



**Figure 20 : Check the Module voltage**

- (4) Setting the CAN ID: Refer the section 9. Module ID Dip Switch Configuration.

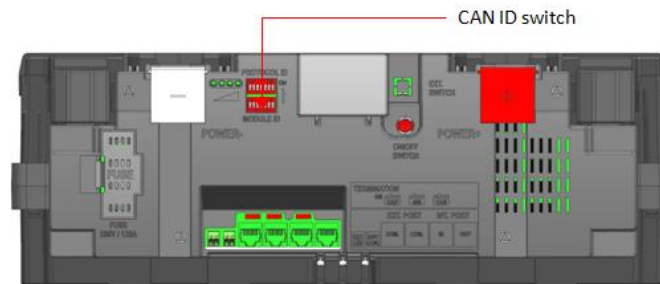

**Figure 21 : CAN ID Setting**

- (5) Setting the Terminating Resistance

CAN and RS485 Bus is used for communication among the Modules or PCS. A terminating resistance must be set at the end of the CAN and RS485 BUS. You must turn on the TR switch of last Module ID number. The TR switch is turned on in only one Module in the system.



CAUTION

**Caution:** If TR switch is turned on in multiple Modules in same system, system may not work.

**CONFIDENTIAL**

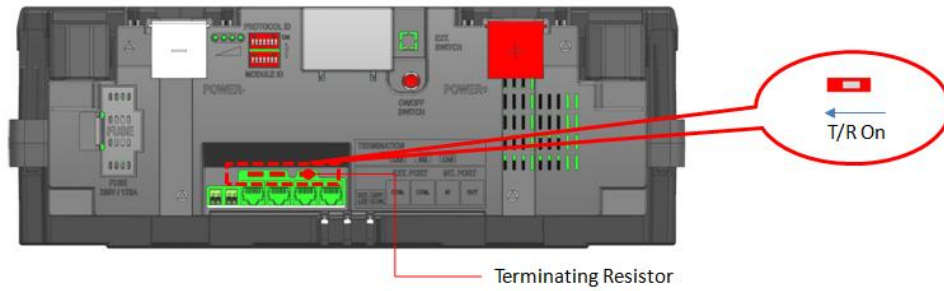

**Figure 22 : Location of TR switch**

In case of single Module system, the TR switch must be switched on.

(6) Connection the Signal Wire

1) Signal connector (Not provided)

Signal connectors use RJ-45 Type connector and Ethernet cable (above CAT-5 standard).

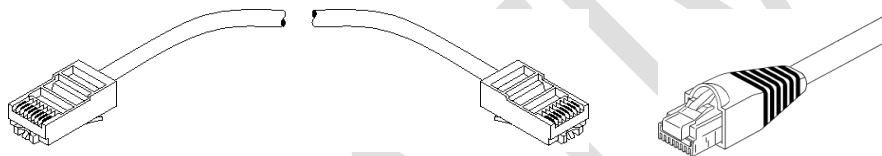

**Figure 23 : Signal connector type**

Refer to the configuration of signal connector between Modules as below.  
Start the Signal Cable connection from CAN out Connector.

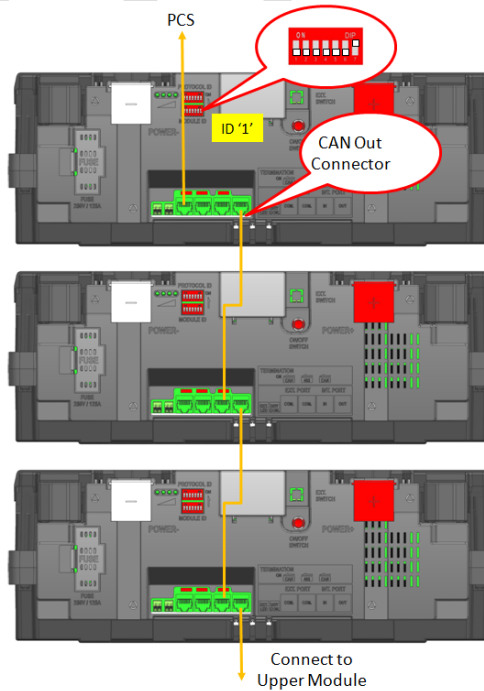

**Figure 24 : Signal cable connection**

(7) Power on the Modules

## CONFIDENTIAL

Push "ON/OFF SWITCH" on module of CAN ID '1' for more than 2 seconds.  
All Modules will be turned on automatically.



CAUTION

**Caution:** Do not press the power switch button for more than 5 seconds during power on status. Module power is turned off if it is pressed for more than 5 seconds.

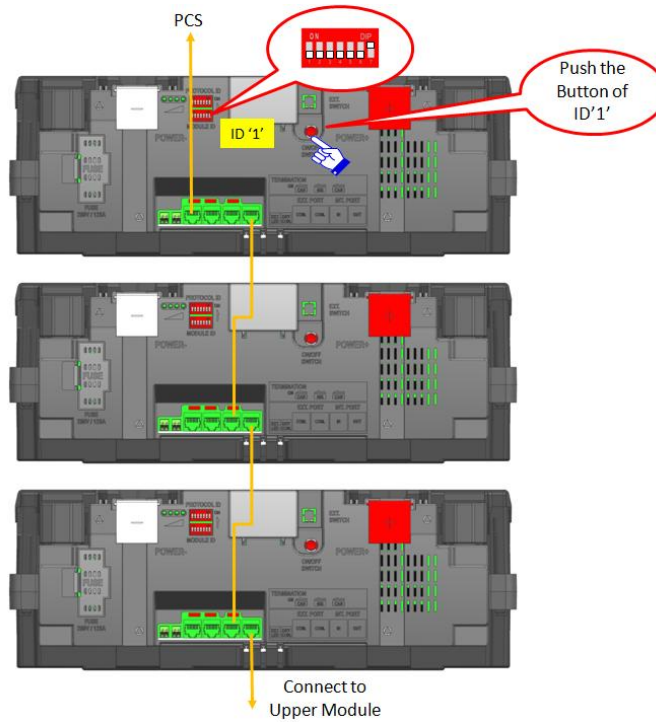

Figure 25 : Turn on system

(8) Check the LED Status: Refer the section

- Confirm the LED of Normal status

(9) Measure the voltage of each module.

All modules within one rack frame must be matched within the voltage difference of 500mV

# CONFIDENTIAL

(10) Power Off the modules

- System Turn Off Sequence

Push "ON/OFF SWITCH" on CAN ID '1' for more than 5 seconds.

Then all Module power is off except switch-pushed Module. And switch-pushed Module LEDs blink.

The Switch-pushed Module power is off when the button is released.

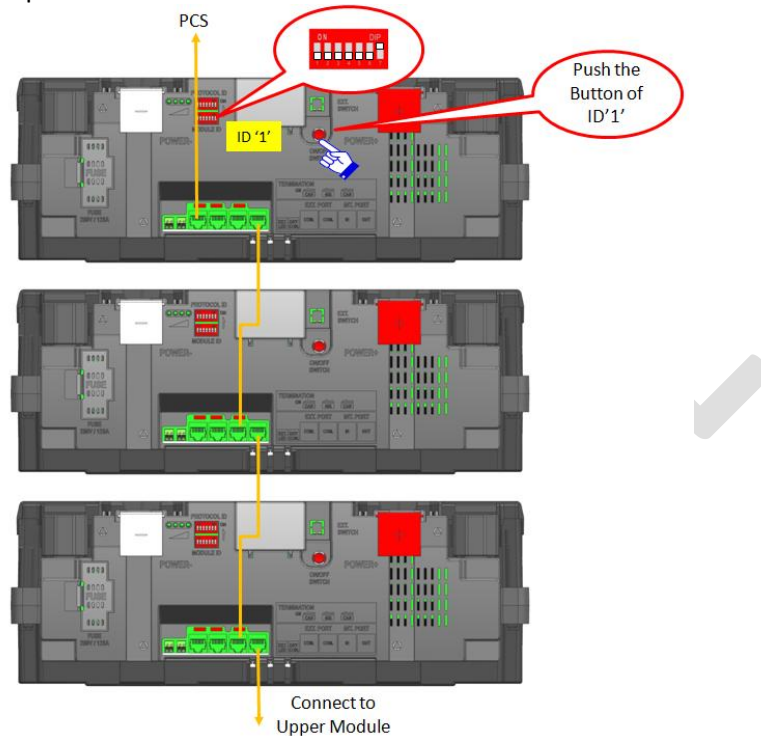

**Figure 26 : Turn off system**

(11) Connecting the power cable: refer the figure 12. Fully installed ESS configuration

Connect the cables to the terminal. Connect the negative cable (-) to the left terminal and positive cable (+) to the right terminal. Tighten the M6 screw to a torque of 3N·m

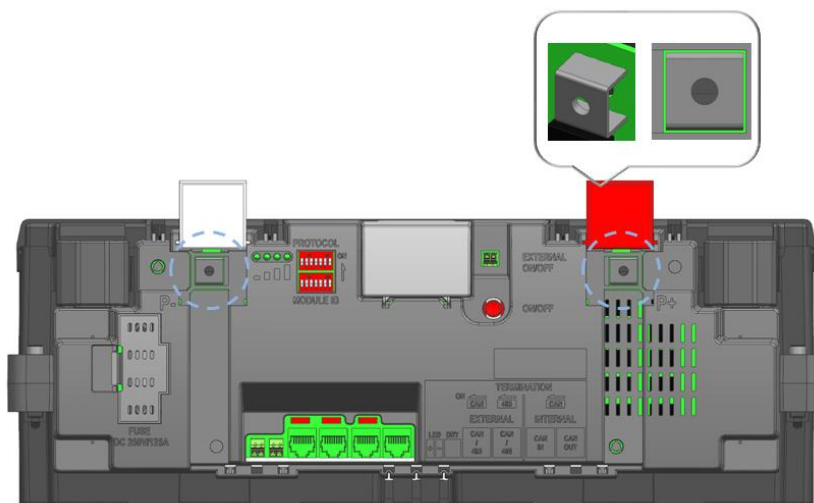

**Figure 27 : Power cable connection**

Product No.	ELPM482-00005	Revision	0.2
-------------	---------------	----------	-----

## CONFIDENTIAL

(12) Power on the Modules

(13) Check the LED Status: Refer the section "LED indication"

Confirm the LED of Normal status

### 11.9 Communication Check(T.B.D)

After installation, wiring, and configuration are completed, you must check the communication status by connecting the CAN cable and run the monitoring program to see whether shows BMS data correctly.

TENTATIVE

Product No.	ELPM482-00005	Revision	0.2
-------------	---------------	----------	-----

**CONFIDENTIAL**

## Contact Information

### Corporate Headquarters

Samsung SDI, Co. Ltd.  
428-5 Gongse-dong, Giheung-gu, Yongin-si, Gyeonggi-do  
Republic of Korea  
Telephone: 82-31-8006-3369  
Homepage: [www.samsungsdi.com](http://www.samsungsdi.com)

### Technical Support (Korea)

Samsung SDI, Co. Ltd.  
ESS Sales Group  
428-5 Gongse-dong, Giheung-gu, Yongin-si, Gyeonggi-do  
Republic of Korea  
Telephone: 82-31-8006-3369  
Homepage: [www.samsungsdi.com](http://www.samsungsdi.com)  
E-mail: [energy.storage@samsung.com](mailto:energy.storage@samsung.com)

CONFIDENTIAL