

**WEBENCH® Design Report**

 Design : 2 TPS563300DRLR  
 TPS563300DRLR 8V-28V to 5.00V @ 2A

**Electrical BOM**

Name	Manufacturer	Part Number	Properties	Qty	Price	Footprint
Cboot	MuRata	GRM155R71A104KA01D Series= X7R	Cap= 100.0 nF ESR= 1.0 mOhm VDC= 10.0 V IRMS= 0.0 A	1	\$0.01	0402 3 mm <sup>2</sup>
Cff	MuRata	GRM1555C1E120JA01D Series= C0G/NP0	Cap= 12.0 pF ESR= 1.0 mOhm VDC= 25.0 V IRMS= 0.0 A	1	\$0.01	0402 3 mm <sup>2</sup>
Cin	TDK	C3216X5R1H106K160AB Series= X5R	Cap= 10.0 uF ESR= 1.0 mOhm VDC= 50.0 V IRMS= 4.9 A	1	\$0.24	1206_180 11 mm <sup>2</sup>
Cinx	TDK	CGA3E2X7R1H104K080AA Series= X7R	Cap= 100.0 nF ESR= 29.6 mOhm VDC= 50.0 V IRMS= 971.99 mA	1	\$0.01	0603 5 mm <sup>2</sup>
Cout	MuRata	GRM32ER61C476KE15L Series= X5R	Cap= 47.0 uF ESR= 3.037 mOhm VDC= 16.0 V IRMS= 4.59346 A	1	\$0.17	1210_280 15 mm <sup>2</sup>
L1	NIC Components	NPI52P7R8MTRF	L= 7.8 uH 18.0 mOhm	1	\$0.36	 IND_NPI52P 445 mm <sup>2</sup>
Rfbb	Vishay-Dale	CRCW040210K0FKED Series= CRCW..e3	Res= 10.0 kOhm Power= 63.0 mW Tolerance= 1.0%	1	\$0.01	0402 3 mm <sup>2</sup>
Rfbt	Yageo	RC0603FR-0752K3L Series= ?	Res= 52.3 kOhm Power= 100.0 mW Tolerance= 1.0%	1	\$0.01	0603 5 mm <sup>2</sup>
U1	Texas Instruments	TPS563300DRLR	Switcher	1	\$0.30	DRL0008A 8 mm <sup>2</sup>

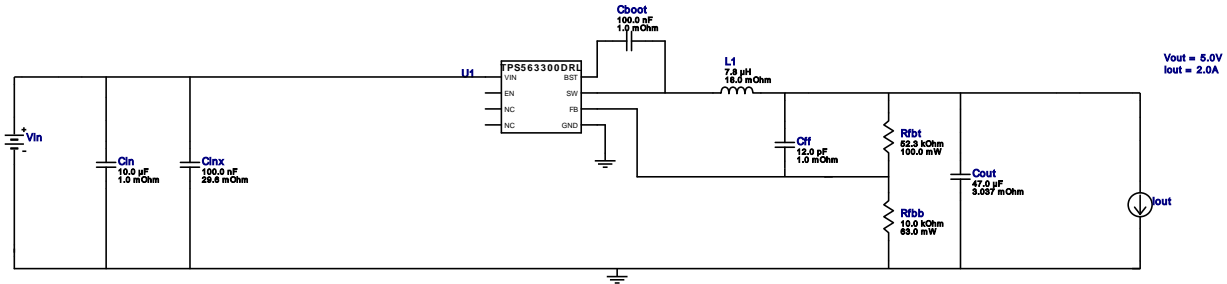
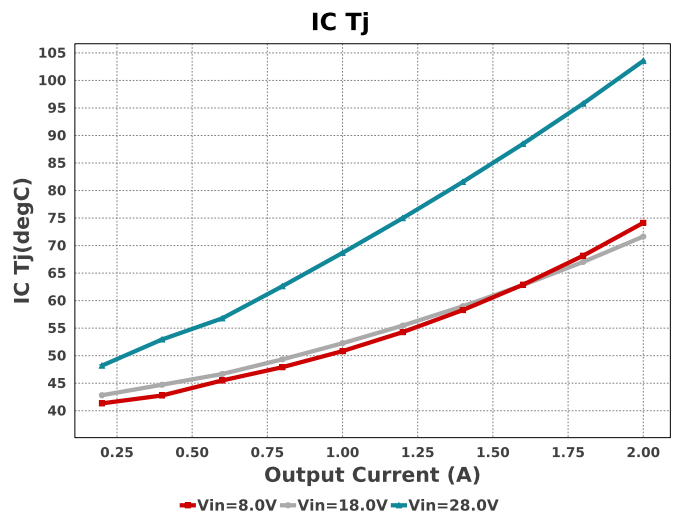
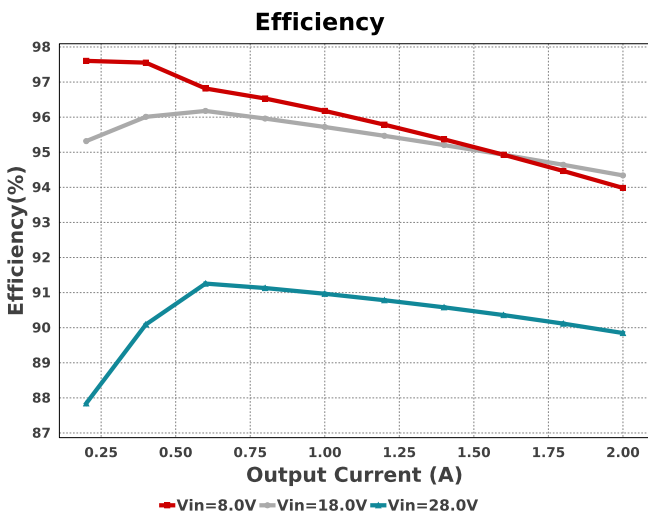
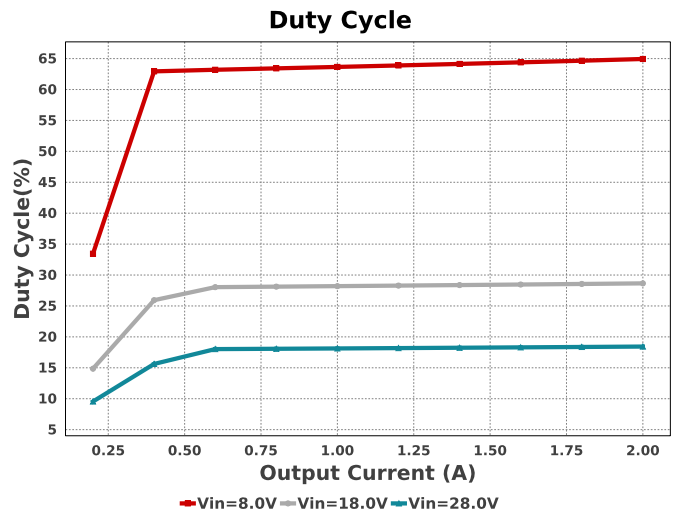
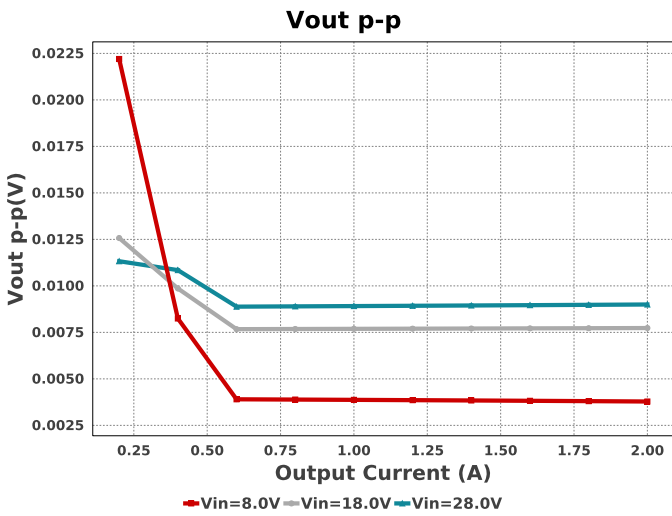
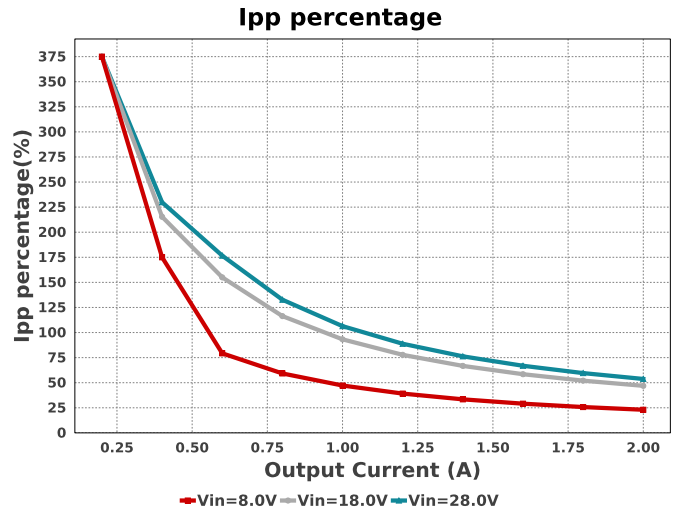
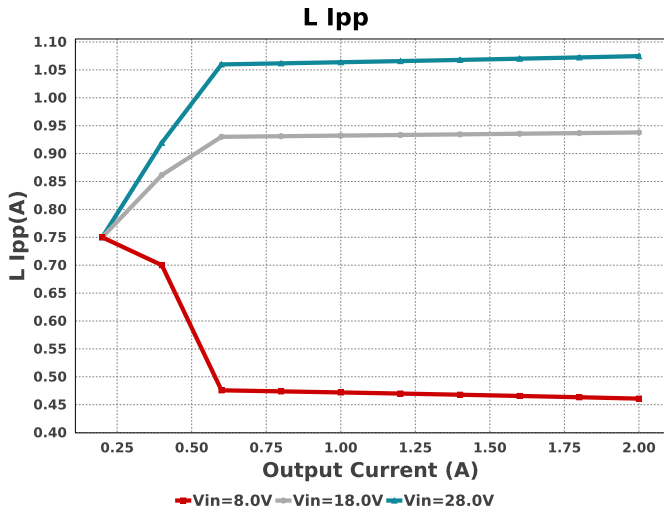
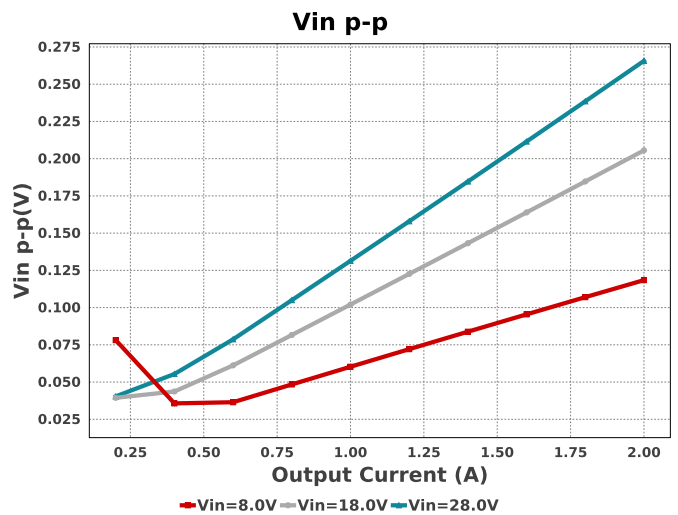
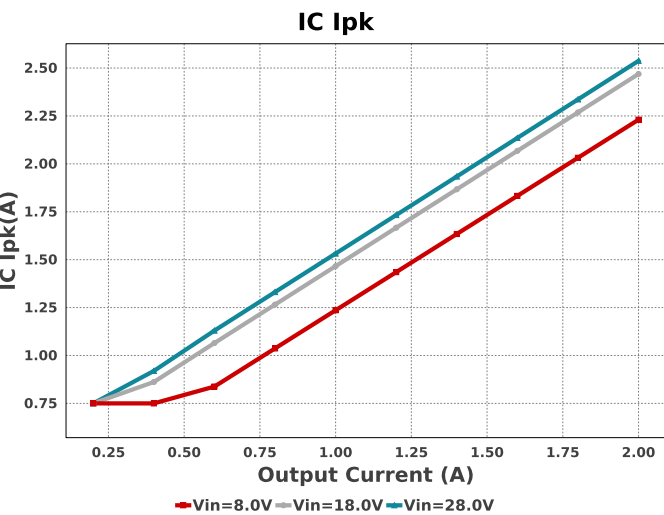
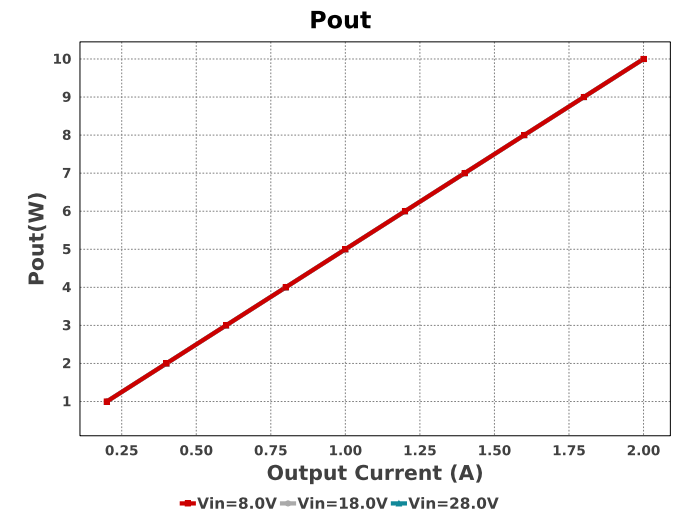
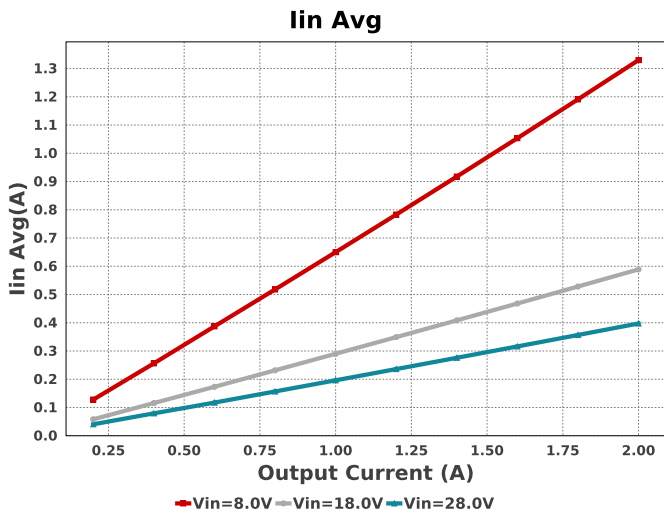
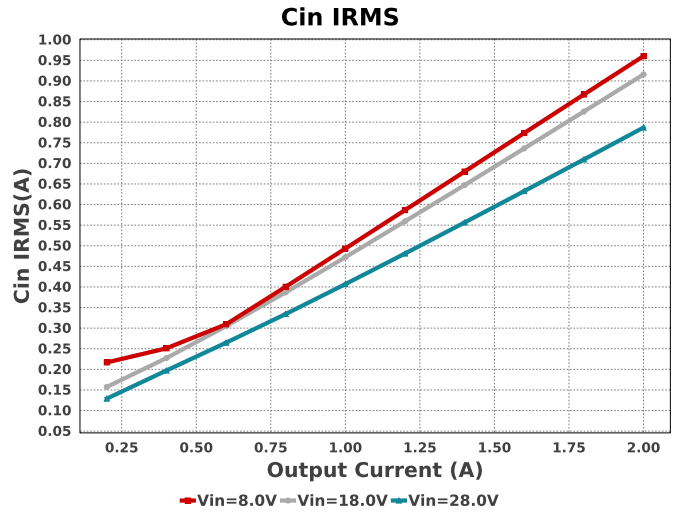
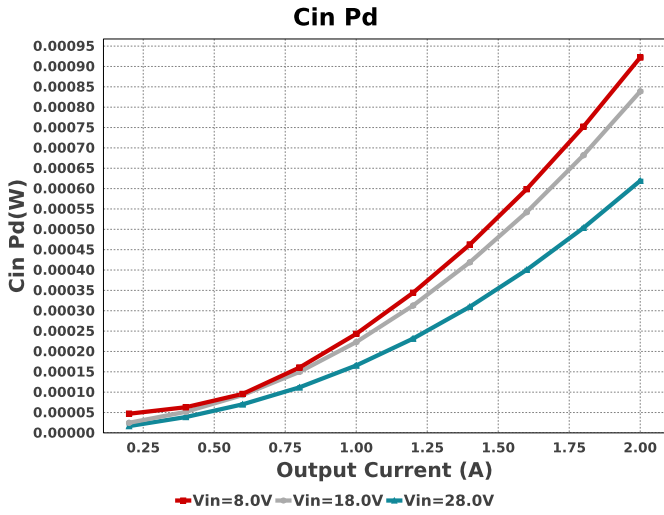

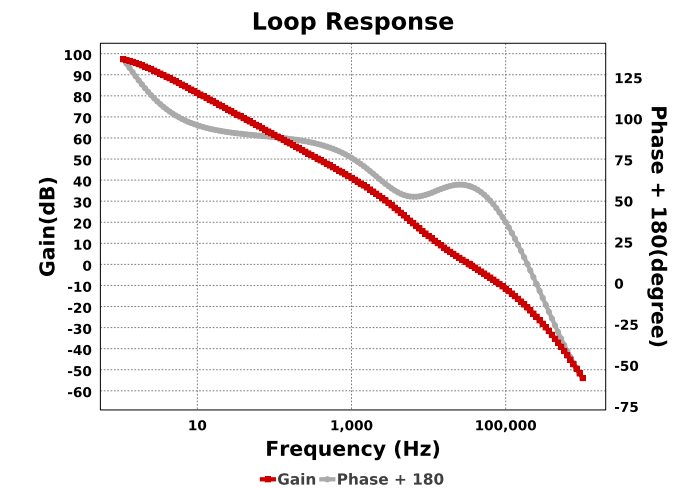
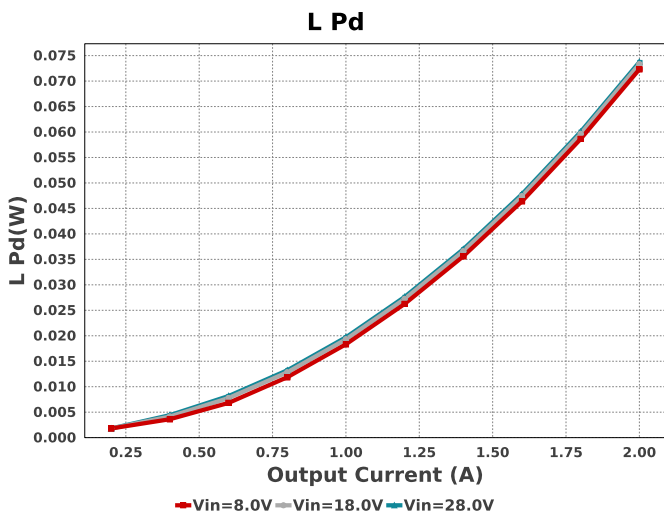
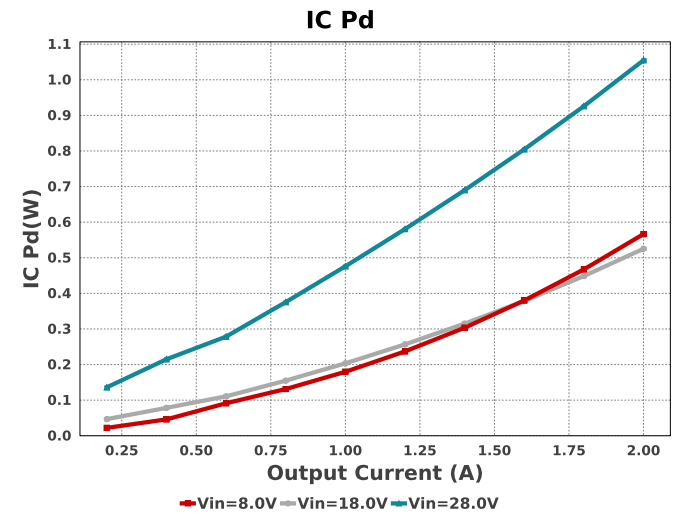
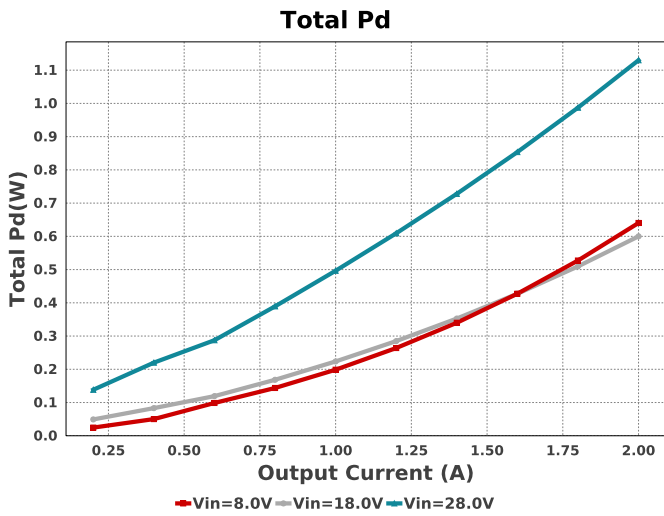
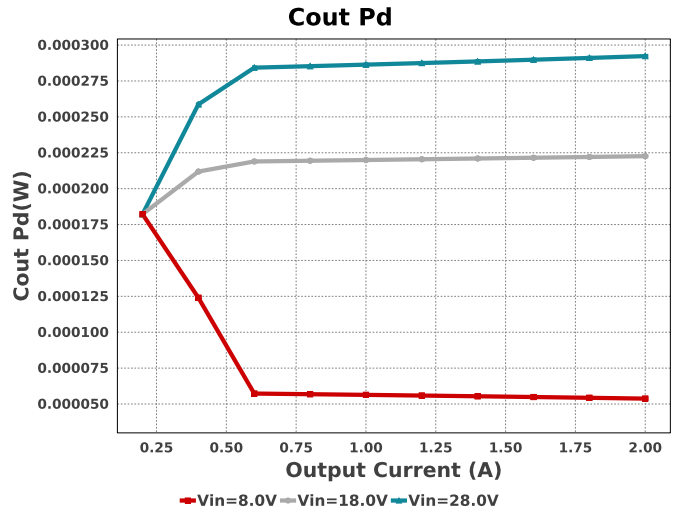
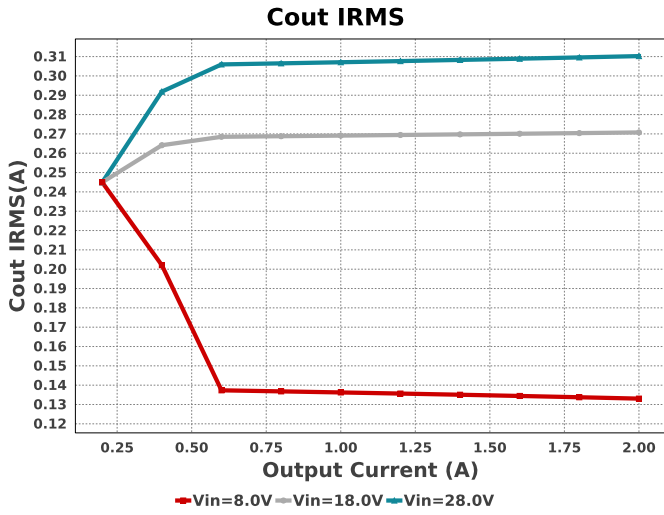

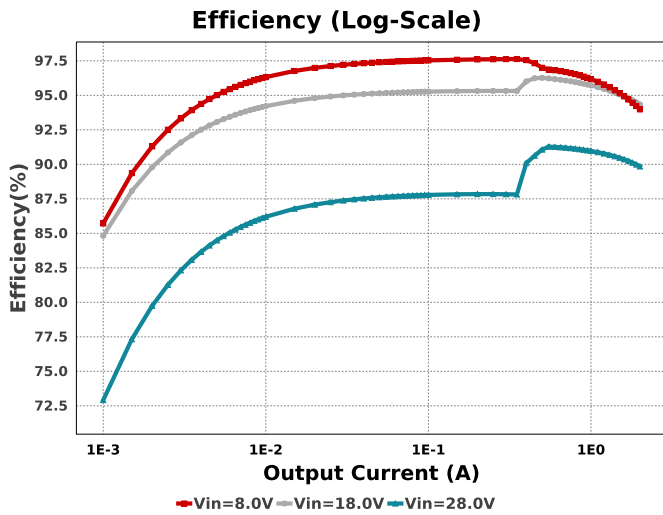



## Operating Values

#	Name	Value	Category	Description
1.	Cin IRMS	786.887 mA	Capacitor	Input capacitor RMS ripple current
2.	Cin Pd	619.19 $\mu$ W	Capacitor	Input capacitor power dissipation
3.	Cout IRMS	310.248 mA	Capacitor	Output capacitor RMS ripple current
4.	Cout Pd	292.32 $\mu$ W	Capacitor	Output capacitor power dissipation
5.	IC Ipk	2.537 A	IC	Peak switch current in IC
6.	IC Pd	1.055 W	IC	IC power dissipation
7.	IC Tj	103.556 degC	IC	IC junction temperature
8.	IC Tolerance	16.0 mV	IC	IC Feedback Tolerance
9.	ICThetaJA Effective	60.25 degC/W	IC	Effective IC Junction-to-Ambient Thermal Resistance
10.	Iin Avg	397.5 mA	IC	Average input current
11.	Ipp percentage	53.736 %	Inductor	Inductor ripple current percentage (with respect to average inductor current)
12.	L Ipp	1.075 A	Inductor	Peak-to-peak inductor ripple current
13.	L Pd	73.733 mW	Inductor	Inductor power dissipation
14.	Cin Pd	619.19 $\mu$ W	Power	Input capacitor power dissipation
15.	Cout Pd	292.32 $\mu$ W	Power	Output capacitor power dissipation
16.	IC Pd	1.055 W	Power	IC power dissipation
17.	L Pd	73.733 mW	Power	Inductor power dissipation
18.	Total Pd	1.13 W	Power	Total Power Dissipation
19.	BOM Count	9	System	Total Design BOM count
20.	Cross Freq	34.116 kHz	System	Bode plot crossover frequency
21.	Duty Cycle	18.434 %	System	Duty cycle
22.	Efficiency	89.848 %	System	Steady state efficiency
23.	FootPrint	497.0 mm <sup>2</sup>	System	Total Foot Print Area of BOM components
24.	Frequency	500.0 kHz	System	Switching frequency
25.	Gain Marg	-24.908 dB	System	Bode Plot Gain Margin
26.	Inductor ripple current requirement used for Inductor selection	40.0 %	System	Custom Inductor ripple current (% of average inductor current) requirement used for Inductor selection
27.	Iout	2.0 A	System	Iout operating point
28.	Iout transient step used for Cout calculations	1.0 A	System	Custom Transient current step requirement that was used for Cout selection (A).
29.	Low Freq Gain	97.379 dB	System	Gain at 1Hz
30.	Mode	CCM	System	Conduction Mode
31.	Overshoot Value	24.609 mV	System	Theoretical Vout Overshoot Value
32.	Phase Marg	59.474 deg	System	Bode Plot Phase Margin
33.	Pout	10.0 W	System	Total output power
34.	Total BOM	\$1.12	System	Total BOM Cost

#	Name	Value	Category	Description
35.	Undershoot Value	57.181 mV	System Information	Theoretical Vout Undershoot Value
36.	Vin	28.0 V	System Information	Vin operating point
37.	Vin p-p	265.671 mV	System Information	Peak-to-peak input voltage
38.	Vout	5.0 V	System Information	Operational Output Voltage
39.	Vout Actual	4.984 V	System Information	Vout Actual calculated based on selected voltage divider resistors
40.	Vout Ripple requirement used for Cout calculations	1.0 %	System Information	Custom maximum output ripple requirement that was used for Cout selection(% of Vout).
41.	Vout Tolerance	3.73 %	System Information	Vout Tolerance based on IC Tolerance (no load) and voltage divider resistors if applicable
42.	Vout p-p	8.999 mV	System Information	Peak-to-peak output ripple voltage
43.	Vout transient requirement used for Cout calculations	3.0 %	System Information	Custom Transient voltage change requirement that was used for Cout selection (% of Vout).

## Design Inputs

Name	Value	Description
Iout	2.0	Maximum Output Current
VinMax	28.0	Maximum input voltage
VinMin	8.0	Minimum input voltage
VinTyp	24.0	Typical input voltage
Vout	5.0	Output Voltage
base_pn	TPS563300	Base Product Number
source	DC	Input Source Type
Ta	40.0	Ambient temperature

## WEBENCH® Assembly

### Component Testing

Some published data on components in datasheets such as Capacitor ESR and Inductor DC resistance is based on conservative values that will guarantee that the components always exceed the specification. For design purposes it is usually better to work with typical values. Since this data is not always available it is a good practice to measure the Capacitance and ESR values of  $C_{in}$  and  $C_{out}$ , and the inductance and DC resistance of L1 before assembly of the board. Any large discrepancies in values should be electrically simulated in WEBENCH to check for instabilities and thermally simulated in WebTHERM to make sure critical temperatures are not exceeded.

### Soldering Component to Board

If board assembly is done in house it is best to tack down one terminal of a component on the board then solder the other terminal. For surface mount parts with large tabs, such as the DPAK, the tab on the back of the package should be pre-tinned with solder, then tacked into place by one of the pins. To solder the tab down to the board place the iron down on the board while resting against the tab, heating both surfaces simultaneously. Apply light pressure to the top of the plastic case until the solder flows around the part and the part is flush with the PCB. If the solder is not flowing around the board you may need a higher wattage iron (generally 25W to 30W is enough).

### Initial Startup of Circuit

It is best to initially power up the board by setting the input supply voltage to the lowest operating input voltage 8.0V and set the input supply's current limit to zero. With the input supply off connect up the input supply to  $V_{in}$  and GND. Connect a digital volt meter and a load if needed to set the minimum load of the design from  $V_{out}$  and GND. Turn on the input supply and slowly turn up the current limit on the input supply. If the voltage starts to rise on the input supply continue increasing the input supply current limit while watching the output voltage. If the current increases on the input supply, but the voltage remains near zero, then there may be a short or a component misplaced on the board. Power down the board and visually inspect for solder bridges and recheck the diode and capacitor polarities. Once the power supply circuit is operational then more extensive testing may include full load testing, transient load and line tests to compare with simulation results.

### Load Testing

The setup is the same as the initial startup, except that an additional digital voltmeter is connected between  $V_{in}$  and GND, a load is connected between  $V_{out}$  and GND and a current meter is connected in series between  $V_{out}$  and the load. The load must be able to handle at least rated output power + 50% ( 7.5 watts for this design). Ideally the load is supplied in the form of a variable load test unit. It can also be done in the form of suitably large power resistors. When using an oscilloscope to measure waveforms on the prototype board, the ground leads of the oscilloscope probes should be as short as possible and the area of the loop formed by the ground lead should be kept to a minimum. This will help reduce ground lead inductance and eliminate EMI noise that is not actually present in the circuit.

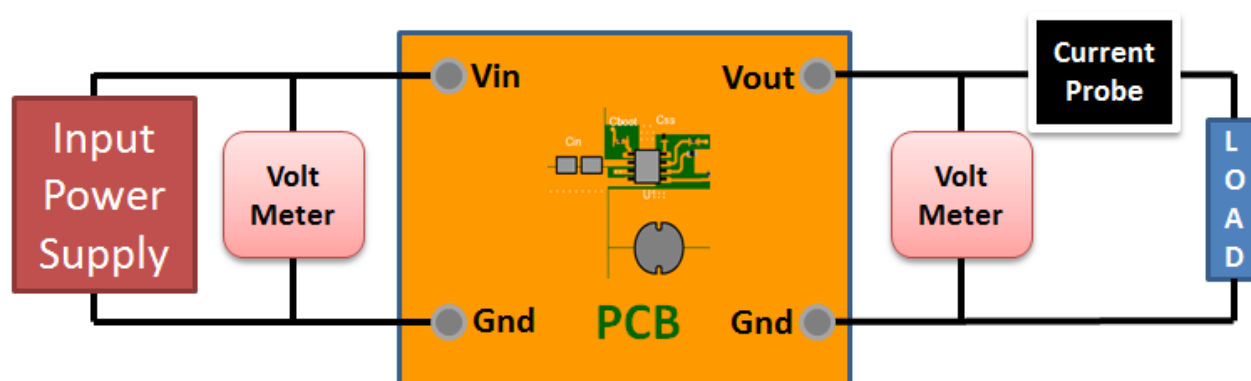

# WEBENCH® Electrical Simulation Report

Design Id = 2

sim\_id = 1

Simulation Type = Startup

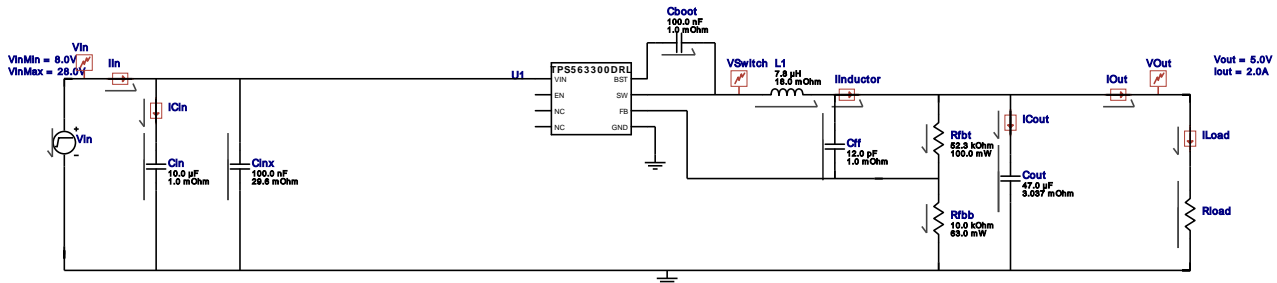

## Simulation Parameters

#	Name	Parameter Name	Description	Values
1.	Cout	IC	Initial Voltage	0 V
2.	Rload	R	Load Resistance	2.5 ohm

## Design Assistance

1. Master key : 2B034EB327CF84239B23B8D8F8B3ED5D[v1]

2. **TPS563300** Product Folder : <https://www.ti.com/product/TPS563300> : contains the data sheet and other resources.

### Important Notice and Disclaimer

TI provides technical and reliability data (including datasheets), design resources (including reference designs), application or other design advice, web tools, safety information, and other resources AS IS and with all faults, and disclaims all warranties. These resources are intended for skilled developers designing with TI products. You are solely responsible for (1) selecting the appropriate TI products for your application, (2) designing, validating and testing your application, and (3) ensuring your application meets applicable standards, and any other safety, security, or other requirements.

These resources are subject to change without notice. TI grants you permission to use these resources only for development of an application that uses the TI products described in the resource. Other reproduction and display of these resources is prohibited. No license is granted to any other TI intellectual property right or to any third party intellectual property right. TI disclaims responsibility for, and you will fully indemnify TI and its representatives against, any claims, damages, costs, losses, and liabilities arising out of your use of these resources.

Providing these resources does not expand or otherwise alter TI's applicable Terms of Sale or other applicable terms available either on ti.com or provided in conjunction with TI products.